

# CO<sub>2</sub> CAPTURE, TRANSPORTATION & STORAGE APPLICATIONS

ISO 13709 / API 610 Pumps • ISO / ANSI Chemical Process Pumps

## 1 CAPTURE AND PROCESS

**Configuration**      **Flowserve Model**

OH2	HPX
BB1	LPN, UZDL
BB2	HDX, HED
BB3	DMX, DMXD
ISO 2858 / 5199	CPX
ANSI B73.1	Mark 3
Hard Metal	MND
Between Bearing	LNN
Liquid Ring Compressor	KPH
Liquid Ring Vacuum Pump	LPH
Recovery system	PL

## 2 PIPELINE - MAINLINE

**Configuration**      **Flowserve Model**

BB3	DMX, DMXD
BB5	WIK/WIKO, HDO/HSO

## 3 PIPELINE - BOOSTER

**Configuration**      **Flowserve Model**

BB2	DVSR
BB3	DMX, DMXD

## 4 PIPELINE - INJECTION

**Configuration**      **Flowserve Model**

BB3	DMX, DMXD
BB5	WIK/WIKO, HDO/HSO

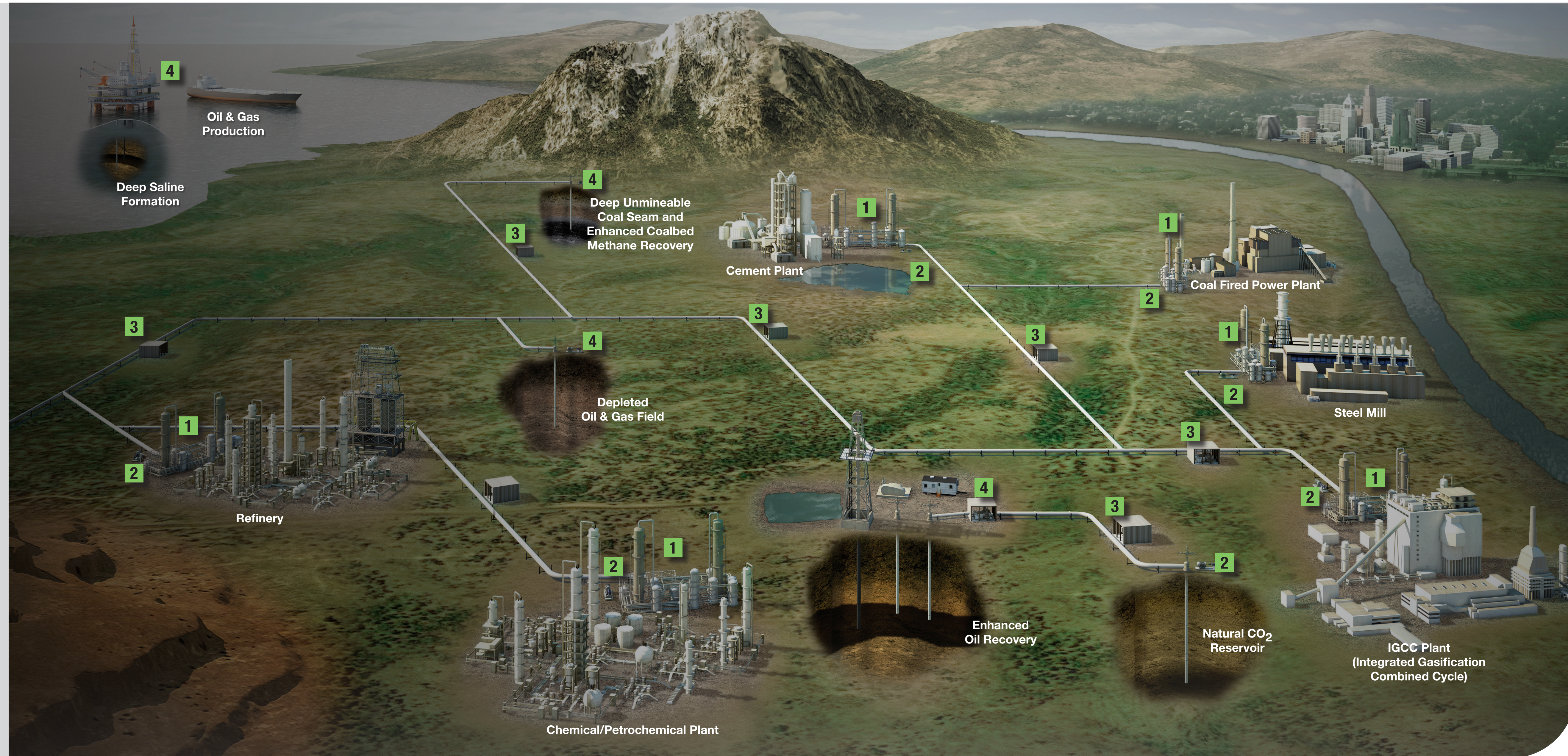

### Byron Jackson®

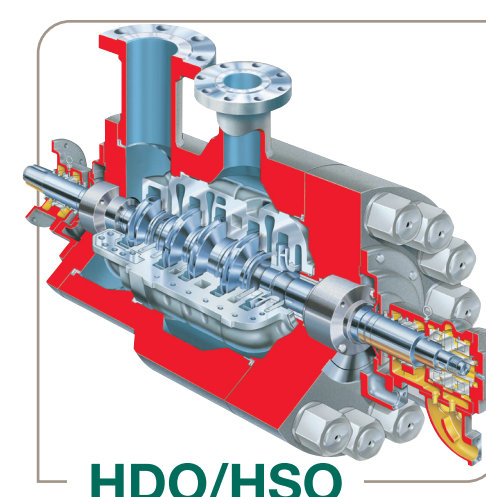
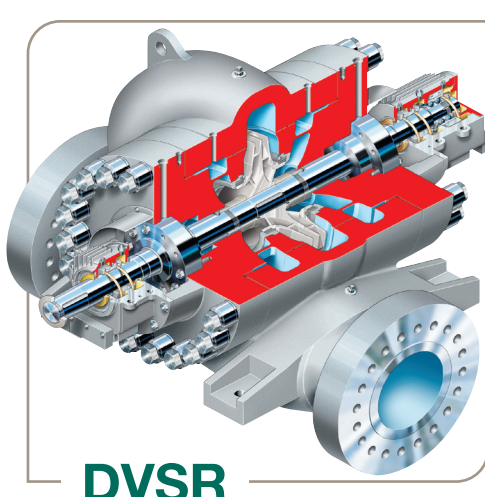

### Durco®

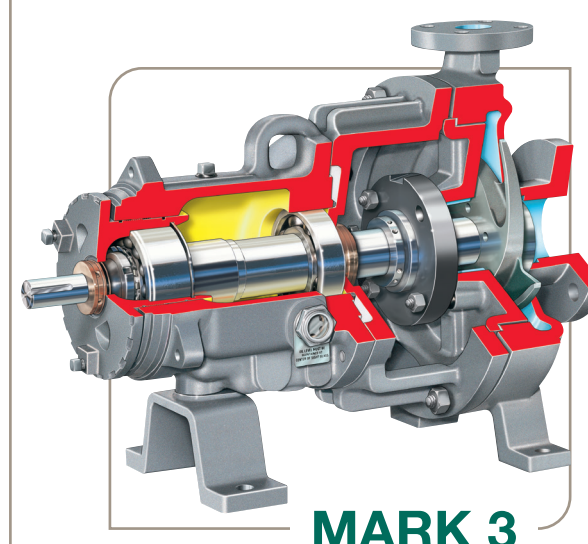

### Flowserve®

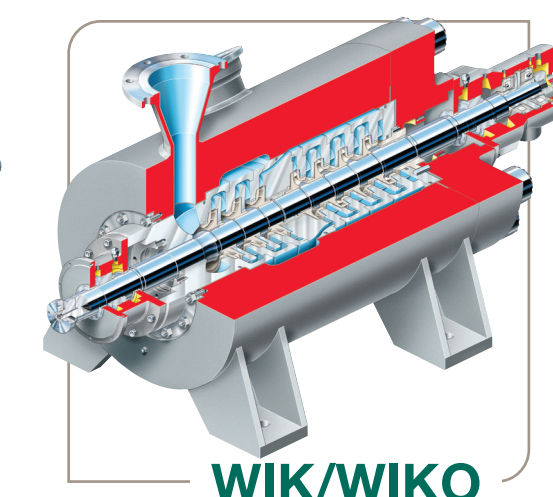
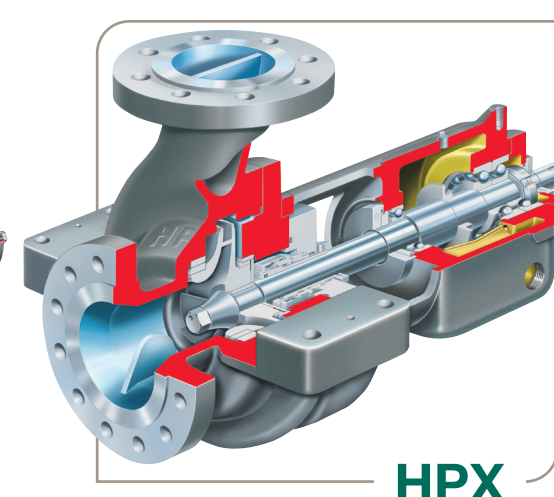
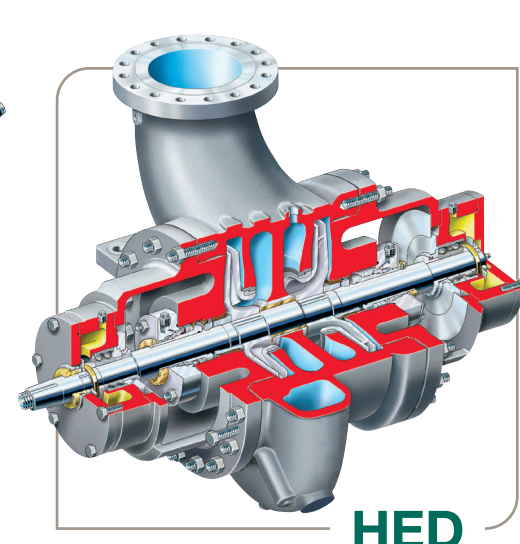
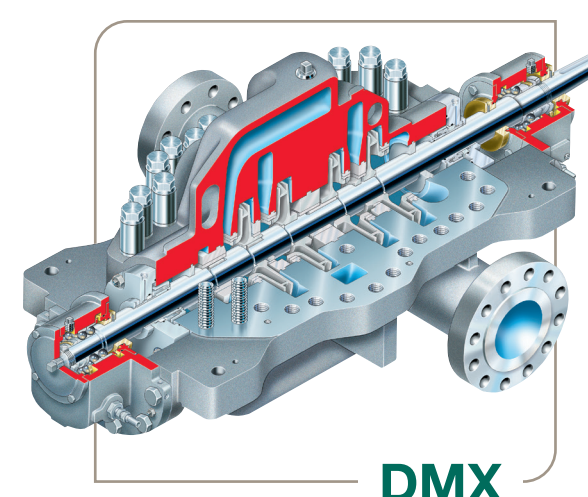

### SIHI®

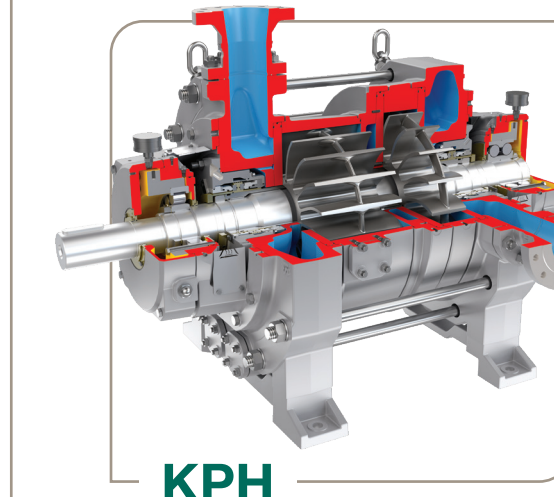

### Worthington®

