

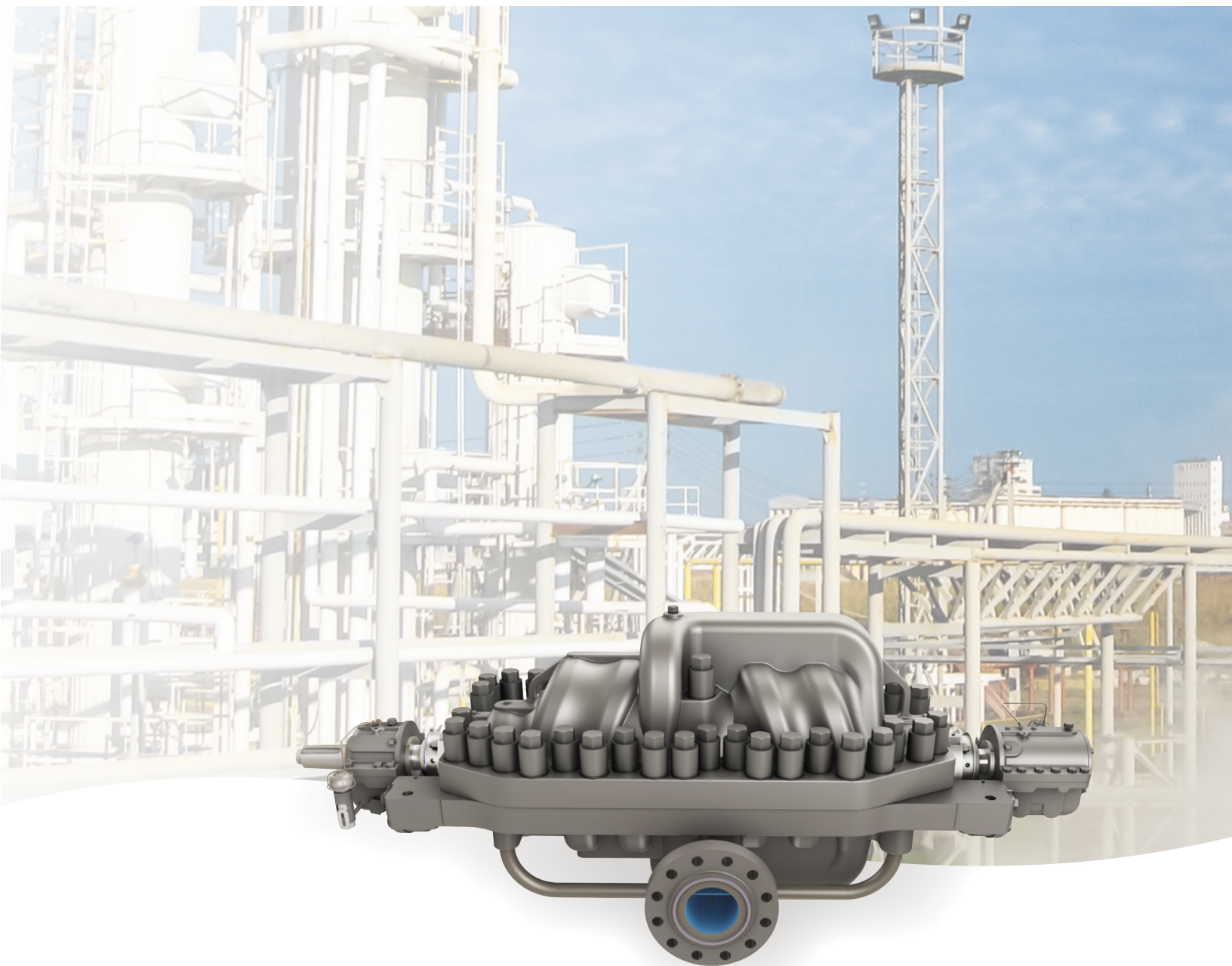

CO₂ Transportation and Injection Pumps

DVSR • DMX/DMXD • HDO/HSO • WIK/WIKO



Experience In Motion



Superior pumping solutions for CO₂ transportation and injection

Companies increasingly are prioritizing energy transition initiatives to reduce greenhouse gas emissions known to cause climate change. They're also taking significant steps to operate more efficiently. Critical technologies will enable these enterprises. Among them is carbon capture usage and storage (CCUS), in which reliable and efficient pumping solutions for CO₂ transportation and injection are critical.

The leader for CO₂ pumps and seals

Whether for pipeline or injection service, Flowserve boasts unrivaled expertise in developing and implementing pump and seal systems for carbon dioxide (CO₂) transportation and storage.

Our specialists understand the challenges associated with pumping and sealing dense phase CO₂ and have innovated many of the technologies the industry relies on today. In 1984, Flowserve pioneered the use of pumps for high-pressure CO₂ pipeline and injection service and later became the first to use dry gas seals in dense phase CO₂ pumps.

You can leverage our engineering prowess and product portfolio to achieve your decarbonization and business objectives. Our pump and seal solutions can deliver the reliability and high operating efficiency you require to minimize operating expenses and extend mean time between repair (MTBR).

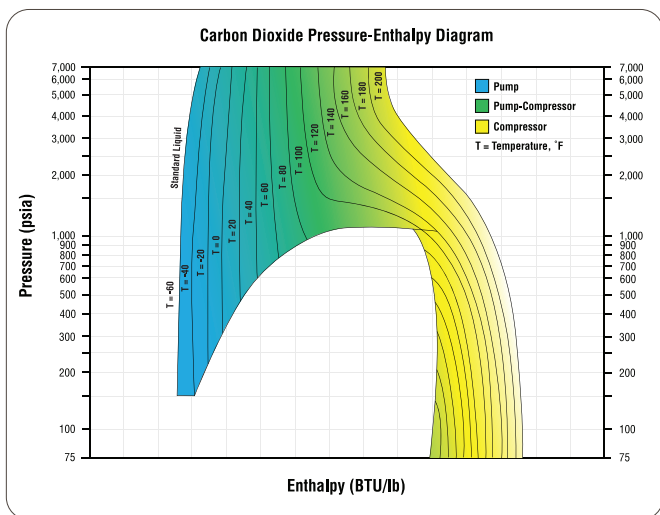

Pumps operate more efficiently than compressors across a broad range of pressures and temperatures in CO₂ transportation and storage processes.



Unsurpassed application knowledge

Flowserve CO₂ specialists have unequaled experience and success in dense phase CO₂ pump and seal technologies. They understand the critical impact that product density, lubricity and contaminants have on the selection and performance of CO₂ pump and seal systems. You can rely on them to help specify reliable and efficient dense phase CO₂ pumping solutions.

Pump designs to meet application needs

Flowserve offers a wide range of pumps for dense phase and supercritical CO₂ applications. Pumps are built to customer and process specifications, often exceeding the requirements of API 610.

- **API performance testing** is conducted on each pump prior to shipment.
- **Materials of construction** are selected to meet service requirements. Options include low-temperature carbon steels, chromium steels and a variety of stainless steels.
- **Wear parts** are made from Graphalloy® or non-metallic materials to compensate for the low lubricity of CO₂.

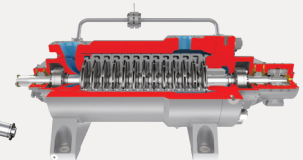
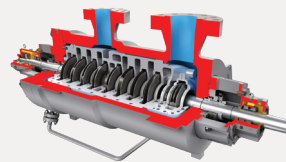
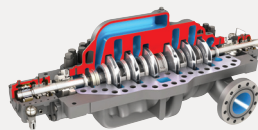
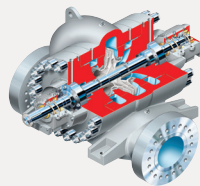

Parameter	DVSR ●●	DMX/DMXD ●●●	HDO/HSO ●●	WIK/WIKO ●●
Configuration	API 610 (BB2)	API 610 (BB3)	API 610 (BB5)	API 610 (BB5)
Flows to	3,635 m ³ /h (16,000 gpm)	5,678 m ³ /h (25,000 gpm)	4,000 m ³ /h (17,600 gpm)	1,600 m ³ /h (7,000 gpm)
Heads to	250 m (820 ft)	2,712 m (8,900 ft)	5,500 m (18,000 ft)	7,000 m (23,000 ft)
Pressures to	260 bar (3,750 psi)	275 bar (4,000 psi)	450 bar (6,525 psi)	650 bar (9,425 psi)

● Transfer/mainline

● Booster

● Injection

© Graphalloy is a registered trademark of Graphite Metallizing Corporation.

DVSR

API 610 (BB2) pump
for pipeline booster
or transfer service

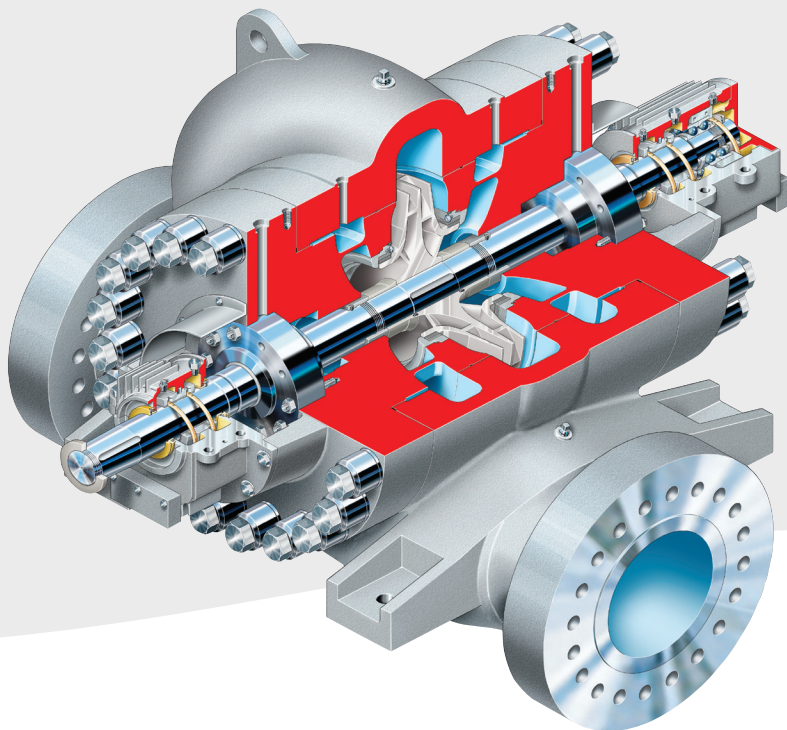

The DVSR pump is the preferred choice for very high-pressure or low-specific gravity applications, such as liquefied gases and dense phase CO₂ pipelines. Consisting of a double-suction impeller operating in a heavy-duty, radially split casing, the DVSR pump's design inherently results in axial and radial thrust balance over the pump's full operating range. Comprehensive hydraulic coverage permits precise sizing, very high efficiency and low total cost of ownership (TCO).

Operating parameters

- Flows to 6,585 m³/h (29,000 gpm)
- Heads to 330 m (1,080 ft)
- Pressures to 260 bar (3,750 psi)
- Speeds to 4,000 rpm



Features and benefits

Radially split casing provides safe containment of dense phase fluids under very high suction pressures. Integral nozzles are designed to handle external forces and moments equal to or in excess of API-specified figures.

Double volute design minimizes hydraulic radial loads, even at minimal flow. The result is prolonged service life for bearings, seals and wear rings.

Raised face flanges meet ASME B16.5 dimensional criteria and are available in Classes 600, 900 and 1500.

Double-suction impeller provides axial hydraulic thrust balance and is designed for maximum hydraulic efficiency.

Stiff shaft design ensures trouble-free performance by operating under the first critical speed.

Multiple bearing designs are available to suit application needs. Designs include sleeve radial/ball thrust, sleeve radial/tilting pad thrust and tilting pad radial/tilting pad thrust configurations.

API 682 seal chambers accommodate wet and dry gas seals as well as cartridge-type single, dual unpressurized and dual pressurized mechanical seals.

DMX/DMXD

API 610 (BB3) pump
for pipeline booster,
transfer and injection
service

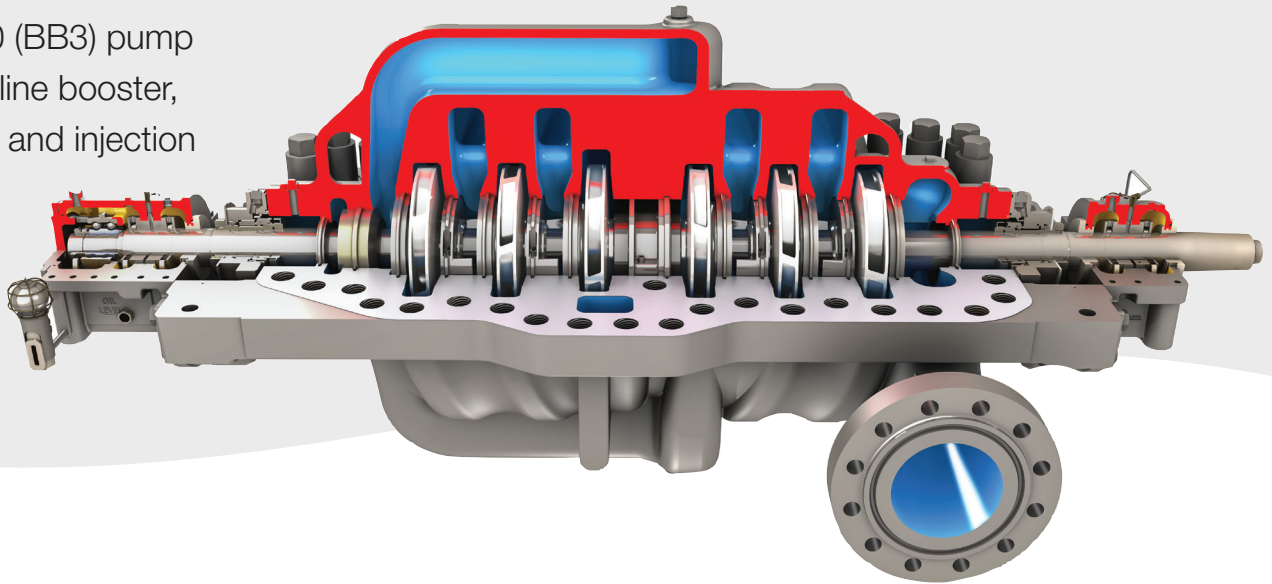

The DMX pump is compliant with API 610, latest edition. It is engineered and built for high-pressure, heavy-duty applications. Boasting a comprehensive hydraulic range, the DMX pump permits precise selection to ensure the best hydraulic fit, operating with efficiency and stability. This helps to minimize operating expenses and extend mean time between repair (MTBR).

Operating parameters

- Flows to 5,678 m³/h (25,000 gpm)
- Heads to 2,712 m (8,900 ft)
- Suction pressures to 146 bar (2,115 psi)
- Pressures to 275 bar (4,000 psi)
- Speeds to 6,000 rpm

Features and benefits

Heavy-duty, axially split casing features double volutes positioned 180 degrees apart so hydraulically generated radial loads are balanced.

Opposed-impeller configuration effectively balances axial thrust over a wide range of operating conditions.

Robust rotating element includes large-diameter shafts and short bearing spans to minimize deflection. Dynamic balancing and TIR verifications ensure optimum mechanical performance.

Available bearing designs include ball radial/ball thrust, sleeve radial/ball thrust and sleeve radial/tilting pad thrust configurations to suit application needs.

API 682 seal chambers accommodate wet and dry gas seals as well as cartridge-type single, dual unpressurized and dual pressurized mechanical seals.

Nozzles are integral with the lower half casing, permitting disassembly without disturbing piping connections. Nozzles are designed to handle external forces and moments equal to or in excess of API values.

Raised face flanges meet ASME B16.5 dimensional criteria. Class 600 suction and discharge minimum. High-pressure casings (for high suction pressure applications) and Class 900, 1500 and 2500 flanges are also available.

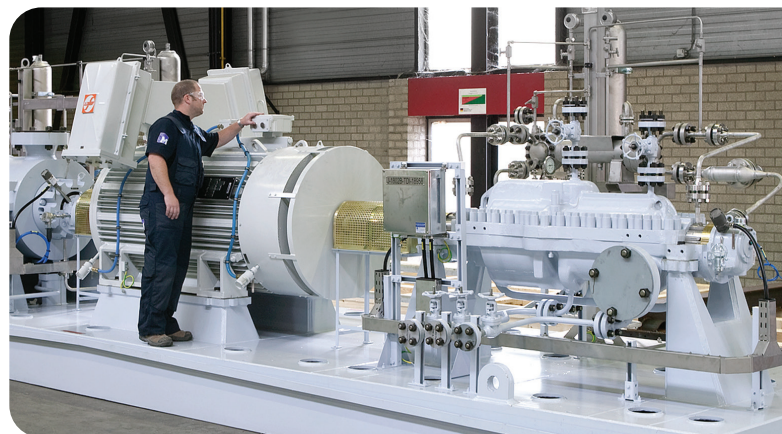

HDO/HSO

API 610 (BB5) pumps
for pipeline transfer
or injection service

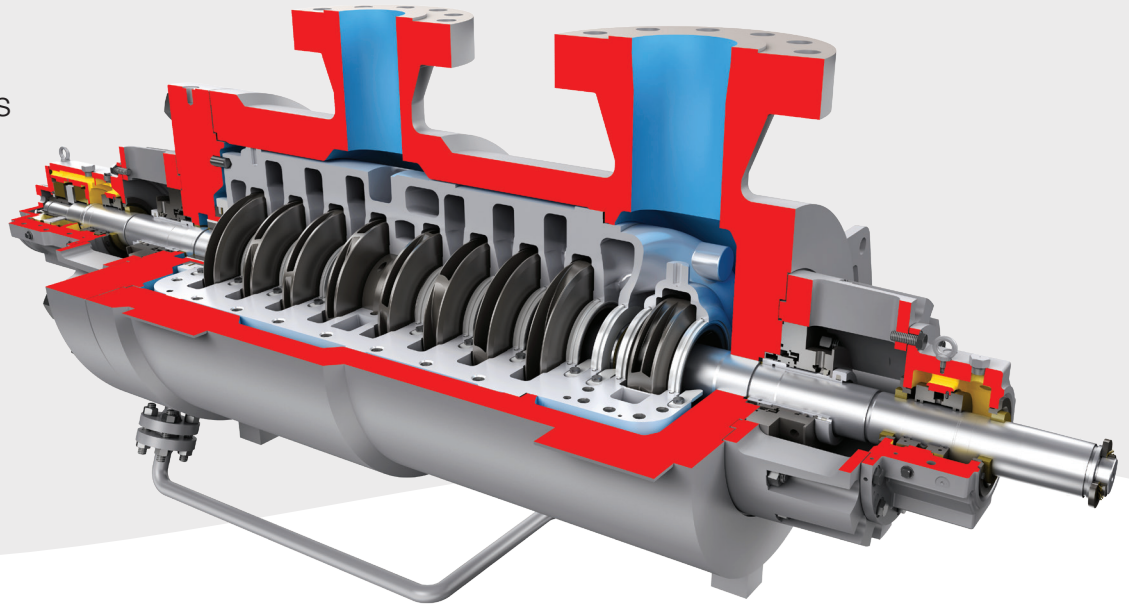

For applications that require the highest reliability and the features of a volute design, HDO/HSO pumps are the optimum choice. Manufactured to customer specifications often exceeding API 610 (BB5), these pumps feature dual volutes with opposed impellers. This design provides nearly balanced axial hydraulic thrust over the full operating range of the pumps.

Standard single-suction (HSO) or optional double-suction (HDO) first-stage impellers provide the flexibility to meet a variety of NPSH requirements.

Operating parameters

- Flows to 4,000 m³/h (17,610 gpm)
- Heads to 5,500 m (18,000 ft)
- Pressures to 450 bar (6,525 psi)
- Speeds to 9,000 rpm

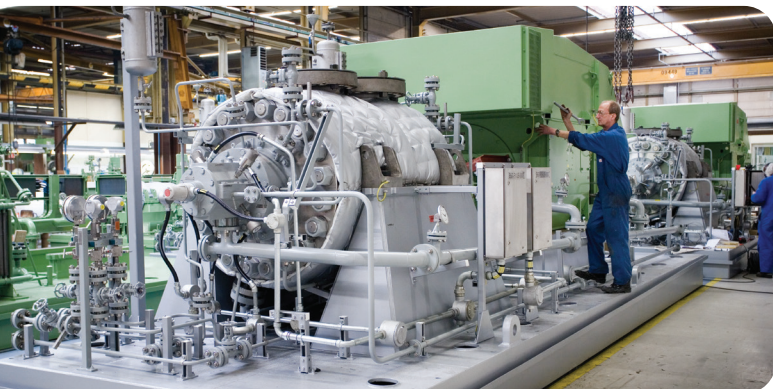

Features and benefits

Double volute casing design consists of two identical halves that feature dual volutes with outlets 180° apart. This design essentially balances radial loads at all operational points, reducing harmful vibration and ensuring dependable performance.

Split-construction stage pieces ease installation in the volute casing.

Precision-cast impellers improve hydraulic efficiency and performance repeatability. Impellers are secured with split rings and a shrink fit to prevent axial movement.

Dynamically balanced rotor provides excellent rotor dynamic stability. The fully assembled rotor is balanced as a complete unit and installed in the volute casing.

Center stage piece breaks down 50% of the discharge pressure to the intermediate stage before the long crossover. It is overlaid with a hard wear surface to eliminate damage from the mating impeller wear surfaces.

Optional grooved impeller running fits increase the pump's tolerance to foreign materials and desensitizes it during start-up, stopping and system transients.

Wrought shafts are incrementally stepped at each impeller fit for ease of assembly. The standard shaft extension is a NEMA taper.

WIK/WIKO

API 610 (BB5) pumps
for pipeline transfer
or injection service

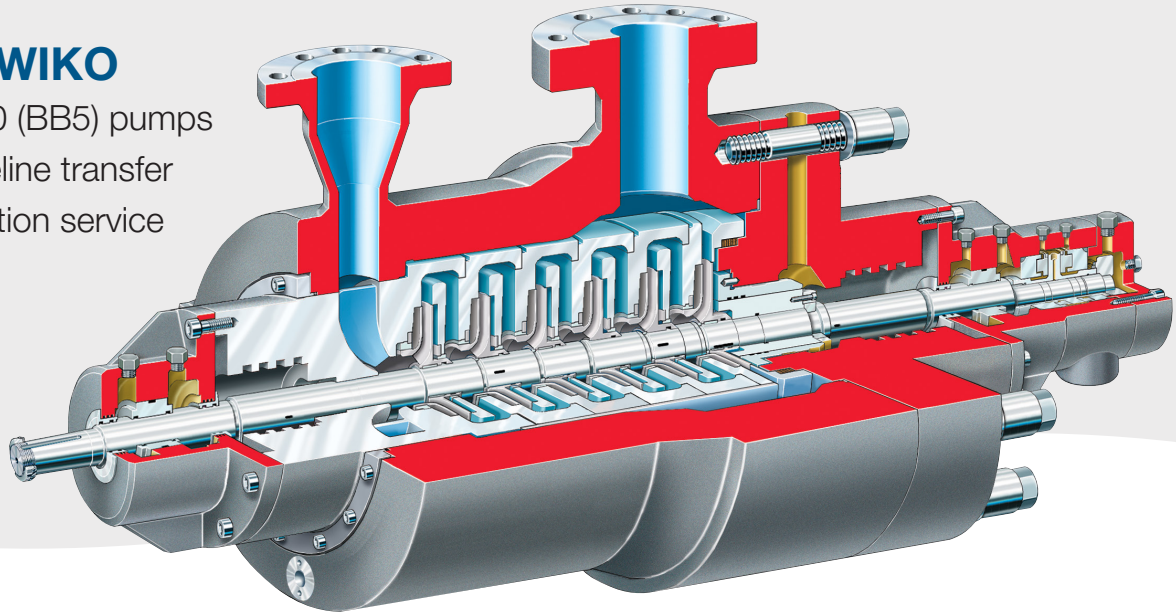

The WIK diffuser-style multistage, double case barrel pump features a tandem (in-line) impeller rotor. The WIKO pump is the opposed impeller variation, capable of handling ultra high injection pressures. They are ideal for special purpose, unspared, high-power density and extremely arduous applications. Both are designed and built to meet or exceed API 610 (BB5), latest edition, and custom-engineered to stringent customer requirements.

Operating parameters

- Flows to 1,600 m³/h (7,000 gpm)
- Heads to 7,000 m (23,000 ft)
- Pressures:
 - WIK: 650 bar (9,425 psi)
 - WIKO: 800 bar (11,603 psi)
- Speeds to 13,000 rpm

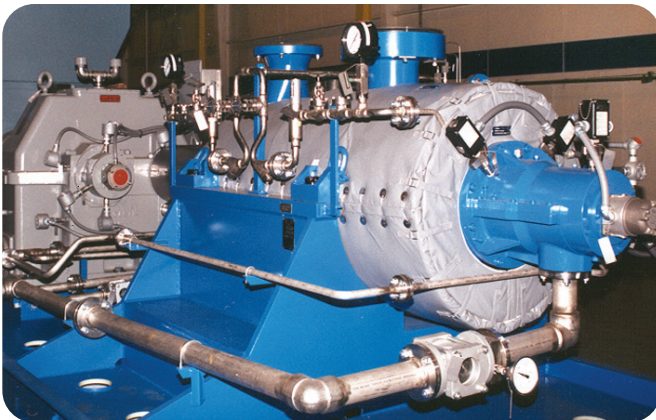

Features and benefits

High-stiffness rotor with low static deflection is the result of a large diameter shaft and short bearing spans. This eliminates the need for Graphalloy or non-metallic stationary wear parts normally required for low-lubricity fluids like CO₂. It also improves the pump's tolerance to operational upsets.

Back pullout cartridge construction allows quick replacement of the entire inner-case subassembly. Maintenance can then be performed in the shop, rather than in the field.

Cast multi-vane radially split diffuser and channel rings eliminate radial imbalance across the entire operating range.

Precision cast, low specific speed impellers are statically and dynamically balanced. Single- and double-suction, first-stage impellers are available.

Heavy-duty, journal-type radial bearings are thick-walled and pressure-lubricated. Heavy-duty, tilting pad thrust bearings feature leading edge groove (LEG) lubrication and are self-equalizing.

API 682 seal chambers accommodate wet and dry gas seals as well as cartridge type single, dual unpressurized and dual pressurized mechanical seals.

Single-diameter balance drum compensates for residual axial thrust.

Optional grooved impeller running fits increase the pump's tolerance to foreign materials and desensitize it during start-up, stopping and system transients.

Proven seal solutions for dense phase CO₂ service



The Flowserve portfolio includes seals ideal for a wide variety of CO₂ applications.

For transportation and injection, CO₂ is compressed into a dense phase that demonstrates properties of a liquid and a gas. Its density and lubricity plus impurities can significantly affect mechanical seal selection and performance.

The gas-like viscosity of dense phase CO₂ makes it difficult to maintain fluid film thickness with traditional liquid seals. Its liquid-like density can create high leakage rates and the potential for atmospheric-side icing with gas seals.

These challenges can only be addressed with advanced technology and innovative engineering solutions. The Flowserve seal portfolio includes proven products for a wide variety of CO₂ applications, including high-pressure and supercritical, dense phase services. Our CO₂ seal specialists can support you in selecting the seal most appropriate for your application.

DHTW/DHTW and UHTW/GSLW seals provide reliable gas-liquid performance

The unique precision seal face topography of these pusher-type mechanical seals from Flowserve provides the hybrid gas-liquid performance needed for CO₂ applications without significant auxiliary systems. They are custom configured to maximize equipment uptime and availability in critical services.

- Dual **DHTW/DHTW** face-to-face seals are suitable for heavy-duty applications requiring zero process emissions.
- Dual **UHTW/GSLW** face-to-back seals are suitable for higher-pressure flashing fluids such as CO₂, ethane, ethylene and LPG.

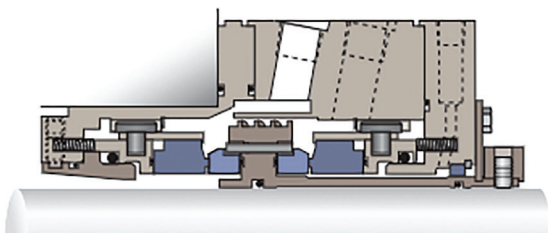

Dual DHTW/DHTW, face-to-face seal

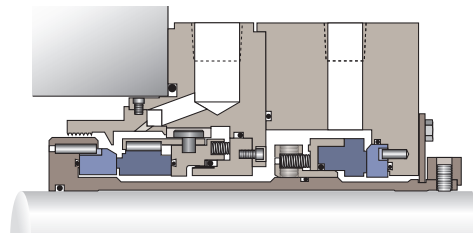

Dual UHTW/GSLW, face-to-back seal

Gaspac seals set the bar in high-pressure applications

Gaspac dry gas seals are engineered to perform over a wide range of operating limits, including supercritical or dense phase CO₂ conditions. Since 2000, more than 200 Gaspac seals from Flowserve have been installed on compressors and continue to reliably handle CO₂ and CO₂-mix gases.

Gaspac seals offer industry-leading technology that withstands the challenging conditions of high-density fluid and ensures high reliability and extremely low leakage. They have been proven in supercritical CO₂ processes that combine high speeds, temperatures and pressures.

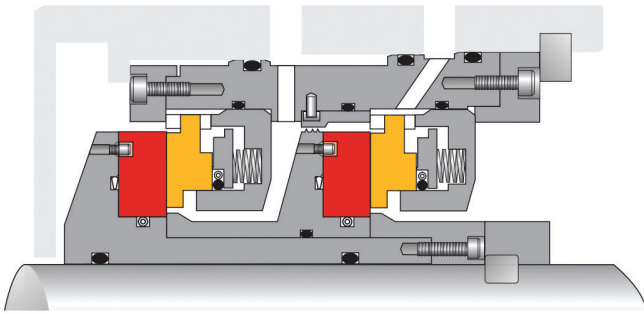

Cross-section of Gaspac L dry gas seal

Support systems to enhance reliability

To maintain the proper seal environment and extend seal life, Flowserve offers a wide range of seal support systems. Commonly used systems include the following:

- Flowserve seal gas panels ensure reliable operation and monitoring of seal performance.
- Our stand-alone Plan 54 and Plan 53B pressurized systems provide barrier fluid for zero process emissions.

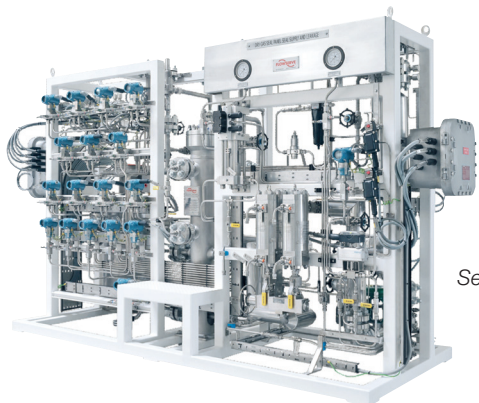

Seal gas panel

Superior design and testing capabilities advance seal performance

To ensure safer, more effective and predictable seal performance under all CO₂ conditions, Flowserve has developed some of the most advanced seal modeling and testing capabilities in the world.

Our seal specialists are constantly innovating wet and dry seal designs. They use advanced analytical techniques, including finite element analysis (FEA) and specialized multi-physics models, to explore and develop new microfeatures and seal face topographies to improve performance.

They have also developed a first-of-its-kind testing facility that can mirror pump operating conditions in CO₂ environments — including dense phase — in order to verify seal performance.

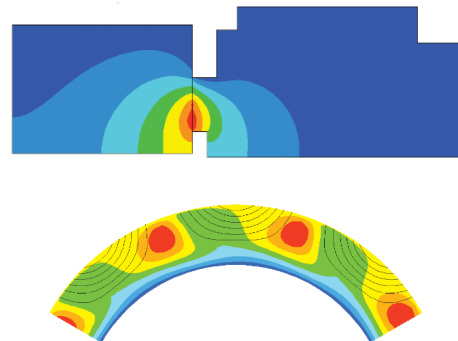

Enhanced finite element analysis predicts temperature and pressure response.



Optimize CO₂ processes with advanced predictive maintenance

Our pumps for CO₂ transportation and injection processes are compatible with RedRaven, the comprehensive predictive maintenance solution from Flowserve. RedRaven predictive maintenance delivers insights that help you improve plant efficiency, productivity and reliability.

RedRaven enables remote monitoring and analytics at your facility so you can predict equipment performance and proactively avoid unplanned downtime.

Benefits and features

- **Predict equipment performance.** Respond to problems quickly and minimize disruptions and downtime. Use trend analysis data to make informed decisions about plant-wide reliability improvements.
- **Optimize maintenance efforts.** Focus on those assets that require attention, thus avoiding unplanned downtime and optimizing maintenance efforts so you spend less time evaluating healthy equipment.
- **Enhance equipment efficiency.** By knowing where all your assets are on their respective pump operating curve, you can optimize them for maximum efficiency.
- **Reduce costs.** Reduce TCO by easily recognizing when to schedule equipment maintenance and reducing spare part inventories.
- **Improve safety.** By alerting technicians to a problem and what the failure mode might be, RedRaven helps them respond to performance issues quickly. Put RedRaven sensors in hazardous locations — not your people.

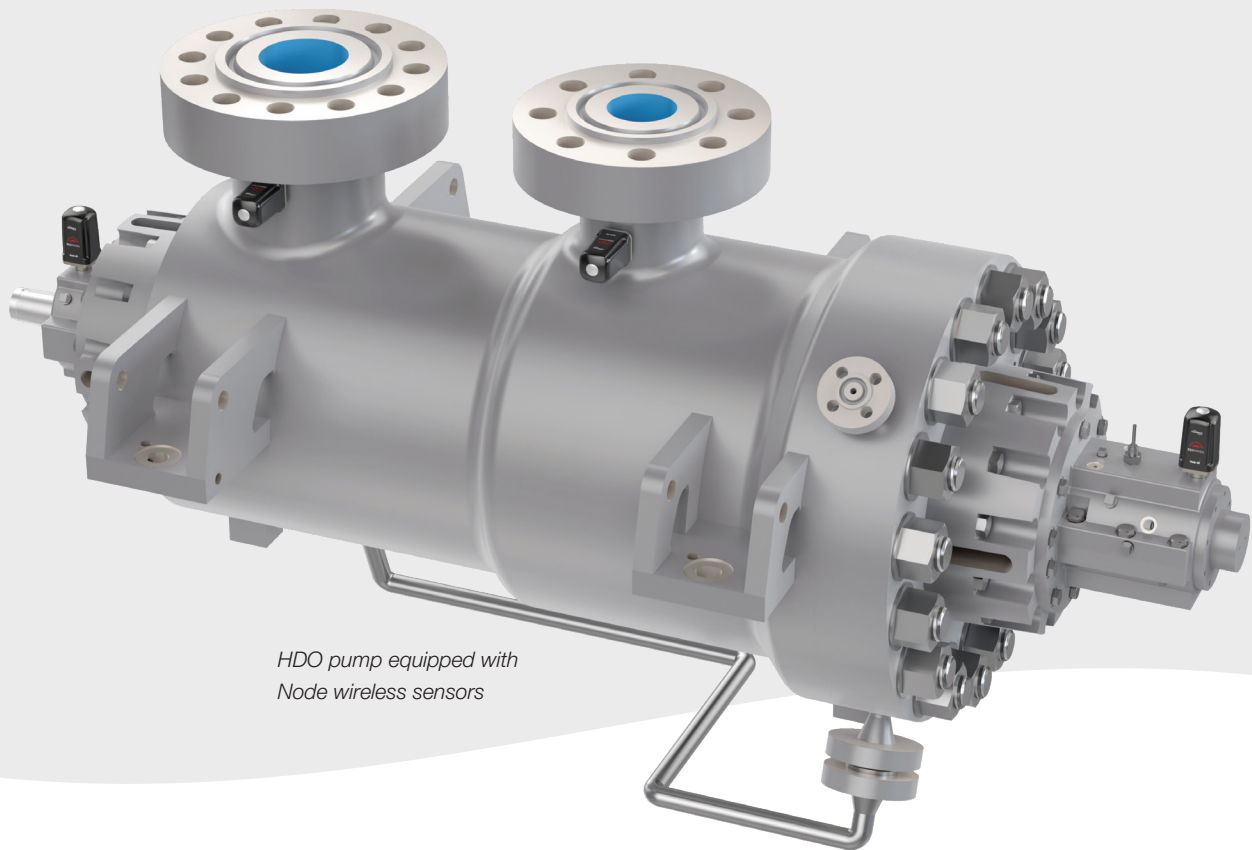

*HDO pump equipped with
Node wireless sensors*

A scalable solution that will grow with you

RedRaven is a predictive maintenance platform that can be customized to meet your operations' unique needs.

Monitoring — Flowserve pumps can be supplied with the Node ER sensor to provide near real-time condition monitoring. Node ER sensors collect a variety of parameters, including three-axis vibration, temperature and pressure every 30 minutes with a wireless range of up to 1 mile in industrial environments.

Analytics — Flowserve pumps can be supplied with Detect sensors wired to a Data Transfer Box to measure velocity vibration data in accordance with DIN/ISO 20816 every 30 seconds. Collected data is used to run predictive analytics that provide early warning of equipment issues before they cause a failure.

RedRaven Insight portal — Predictive maintenance readings are shown in the RedRaven Insight portal. The web-based portal allows users to view their data from anywhere and set custom alerts to watch over equipment 24/7. Users also get the peace of mind that the Flowserve Monitoring Center is looking out for alerts and providing recommendations to improve uptime.



Find out more

Ask your Flowserve representative about optional RedRaven predictive maintenance packages or visit www.flowserve.com/redraven to learn more.

Success story

Predictive analytics system improves Benfield plant reliability

Challenge

An ammonia/urea facility experienced recurring failures on its lean Benfield solution pumps used to remove CO₂ from process gas. Shaft failures were occurring every six to nine months, costing the plant hundreds of thousands of (U.S.) dollars in maintenance and downtime. A study by Flowserve confirmed that gas foaming was creating vibration that caused the shafts to fail due to fatigue.

Solution

Flowserve worked with the customer to design application-specific predictive analytics to identify the onset of aeration in the system by continuously monitoring operating conditions of the Benfield pumps. Flowserve also designed the hardware needed to see alerts at the pump and in the control room, making operators aware that corrective action was needed.

Results

This monitoring system lengthened the mean time between failure (MTBF) of the pump shafts to more than three years. This significantly reduced the lifecycle cost of the Benfield solution pumps.

To learn how RedRaven condition monitoring and predictive analytics can improve your equipment and system reliability, visit www.flowserve.com/redraven.

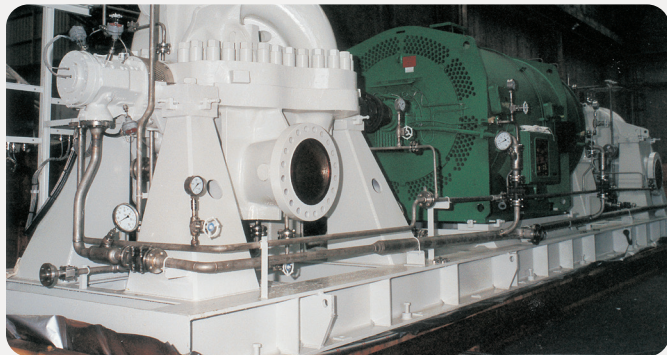

Flowserve Corporation
5215 North O'Connor Blvd.
Suite 700
Irving, Texas 75039-5421 USA
Telephone: +1-937-890-5839

PUBR000407-02 (EN/AQ) March 2023
(Formerly PS-30-17)

Flowserve Corporation has established industry leadership in the design and manufacture of its products. When properly selected, this Flowserve product is designed to perform its intended function safely during its useful life. However, the purchaser or user of Flowserve products should be aware that Flowserve products might be used in numerous applications under a wide variety of industrial service conditions. Although Flowserve can provide general guidelines, it cannot provide specific data and warnings for all possible applications. The purchaser/user must therefore assume the ultimate responsibility for the proper sizing and selection, installation, operation, and maintenance of Flowserve products. The purchaser/user should read and understand the Installation Instructions included with the product, and train its employees and contractors in the safe use of Flowserve products in connection with the specific application.

While the information and specifications contained in this literature are believed to be accurate, they are supplied for informative purposes only and should not be considered certified or as a guarantee of satisfactory results by reliance thereon. Nothing contained herein is to be construed as a warranty or guarantee, express or implied, regarding any matter with respect to this product. Because Flowserve is continually improving and upgrading its product design, the specifications, dimensions and information contained herein are subject to change without notice. Should any question arise concerning these provisions, the purchaser/user should contact Flowserve Corporation at any one of its worldwide operations or offices.

©2023 Flowserve Corporation. All rights reserved. This document contains registered and unregistered trademarks of Flowserve Corporation. Other company, product, or service names may be trademarks or service marks of their respective companies.