

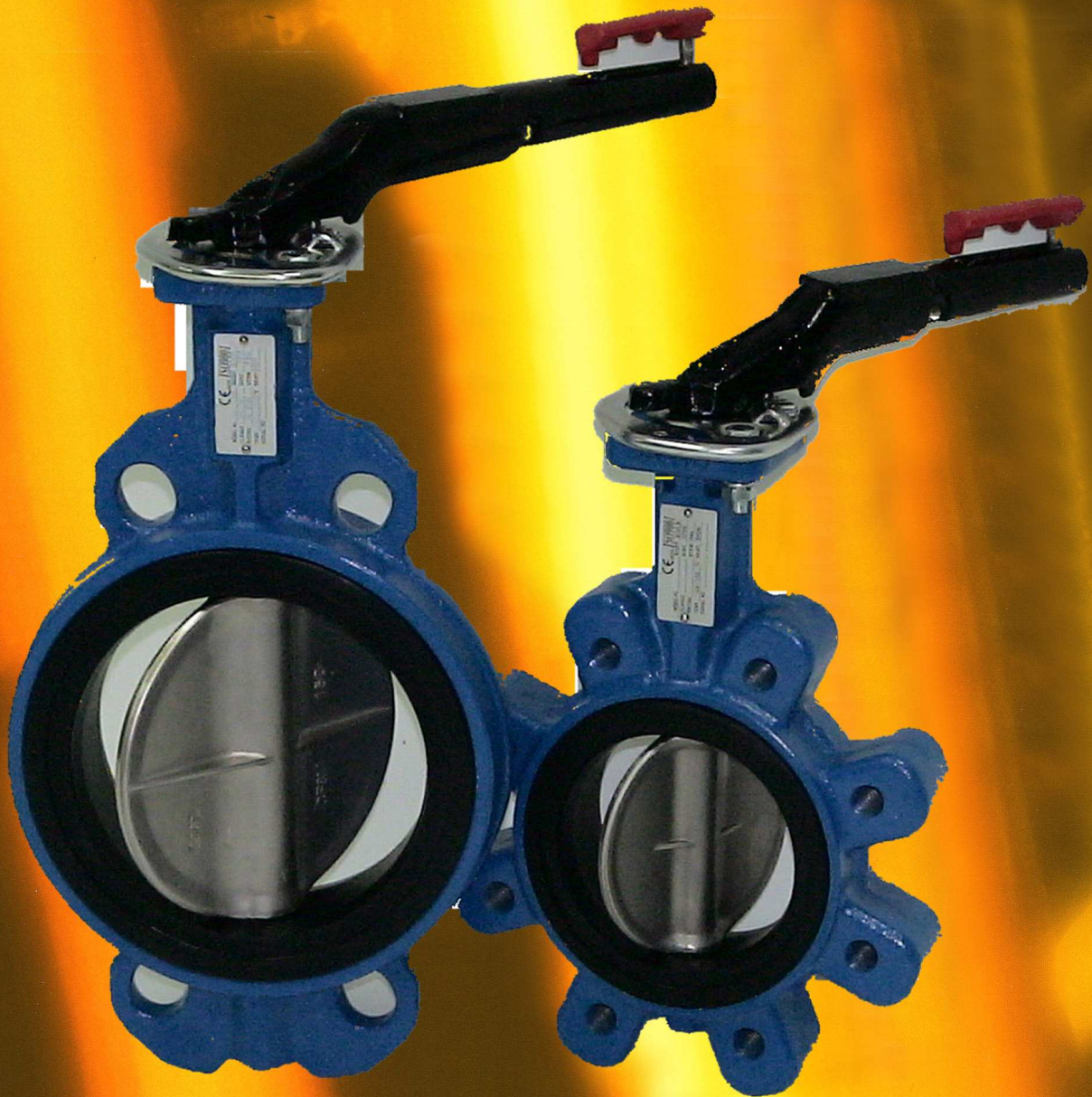

Flowserve RX Butterfly Valves
Rubber Seated



Experience In Motion

Introducing...

FLOWSERVE **RX** BUTTERFLY VALVES



- Sizes: 40mm/1.5"-1000mm/40"
 - Pressure rating:
 - 16 bar/230 psi for 40mm/1.5"-300mm/12"
 - 10 bar (150 psi) for 350mm/14"-1000mm/40"
 - Valves with seats in Viton or Silicone are limited to 6 bar (90 psi) maximum pressure
 - Wafer, lug, or double flange
 - Flange connections available:
 - ANSI 125/150
 - DIN PN10
 - DIN PN 16
-
- Available in a wide variety of seats including Nitrile, EPDM, EPT, Neoprene, Silicone, Hypalon, Viton
 - Range of discs includes Nylon-coated ductile iron, Stainless steel, aluminum-bronze and super duplex stainless steel
 - The close tolerance square stem reduces hysteresis
 - Bi-directional bubble-tight shut-off
 - High strength through-stem design allows easy disassembly by merely pulling the stem out of the disc without special tools
 - Our design requires no disc screws or taper pins, which commonly result in leak paths, corrosion, and vibration failures.
 - Stem seal features double o-rings



Materials DN40-DN600 1.5"-24"

RXW Wafer
RXL Lug
RXF Flange

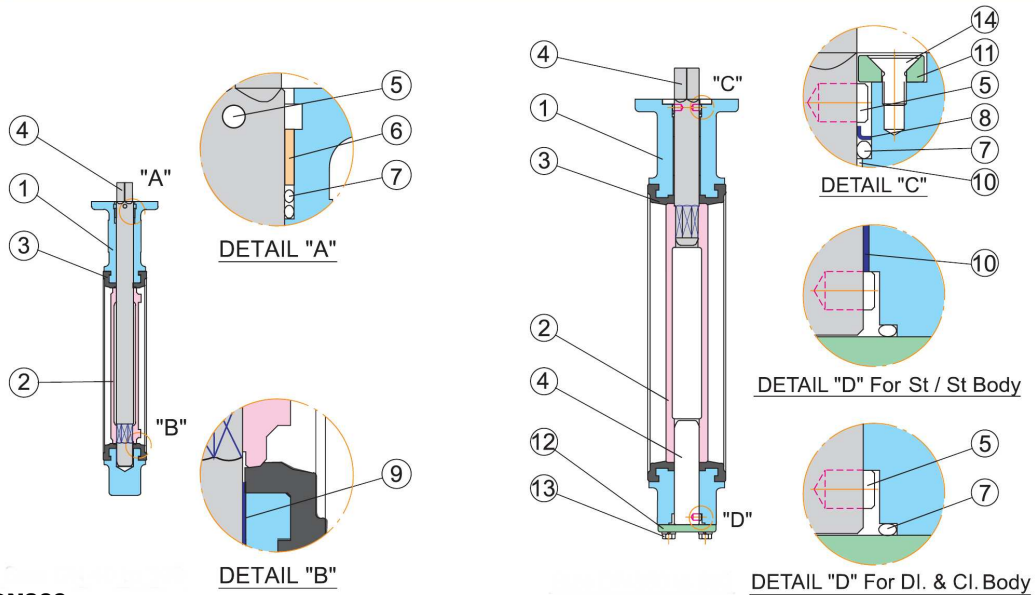

**DN40-DN300
1.5"-12"**

**DN350-DN600
14"-24"**

No.	Name	Materials	Specification		Remark
			JIS	ASTM	
1	BODY	CAST IRON	FC 200	A126 Cl. B	WAFER (1.5"-24")
		DUCTILE IRON	FCD 400	A395	(1.5"-24")
		STAINLESS STEEL	SCS 13A SCS 14A	A351 Gr. CF8 A351 Gr. CF8M	ALL MODELS (14"-24")
2	DISC	DUCTILE IRON	FCD 400	A395	Nylon 11 coated
		STAINLESS STEEL	SCS 13A SCS 14A	A351 Gr. CF8 A351 Gr. CF8M	
		ALU-BRONZE	ALBC2	B148 C95400	
3	SEAT	NBR (NITRILE)			-10 ° ~ 80 °C (14 ° ~ 176 °F)
		EPDM			-20 ° ~ 120 °C (-4 ° ~ 248 °F)
		EPT			-20 ° ~ 140 °C (-4 ° ~ 284 °F)
		NEOPRENE (CR)			0 ° ~ 80 °C (32 ° ~ 176 °F)
		SILICON			-20 ° ~ 180 °C (-4 ° ~ 356 °F)
		HYPALON (CSM)			-20 ° ~ 135 °C (-4 ° ~ 275 °F)
4	STEM	STAINLESS STEEL	SUS 410	A182 Gr. F6A	
			SUS 304	A182 Gr. F304	
			SUS 316	A182 Gr. F316	
5	PIN	STAINLESS STEEL	SUS 304	A182 Gr. F304	
6	BUSH	DELRIN			
7	O-RING	NBR (NITRILE)			
8	THRUST RING	STAINLESS STEEL	SUS 304	A240 Gr. 304	
9	BUSH	BRONZE	BC6	B62	For cast iron and ductile iron body
10	BUSH	RTEF+STAINLESS STEEL	RTEF+SUS316	RTEF+A240 Gr. 316	
11	UPPER COVER	CAST IRON	FC 200	A126 Cl. B	For cast iron and ductile iron body
		STAINLESS STEEL	SCS 13A	A351 Gr. CF8	For stainless steel body
12	BOTTOM COVER	CAST IRON	FC 200	A126-B	For cast iron and ductile iron body
		STAINLESS STEEL	SCS 13A	A351 Gr. CF8	For stainless steel body
13	BOLT	STEEL			
14	BOLT	STEEL			



Materials DN650-DN1200 26"-48"

RXW Wafer
RXF Flange

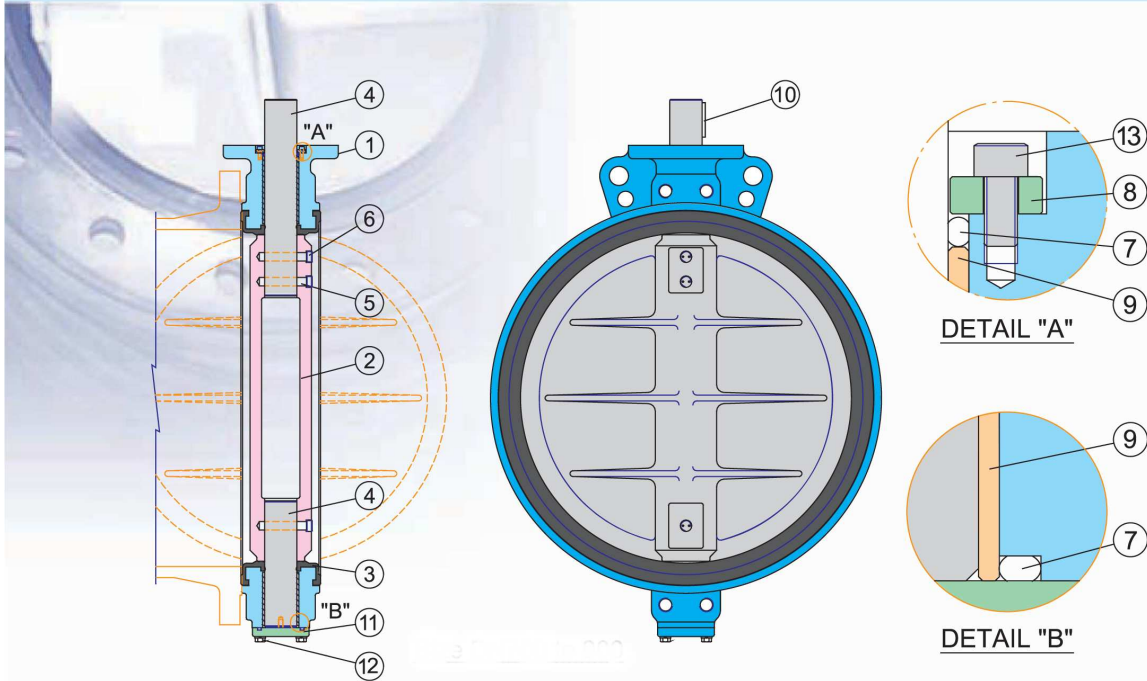

No.	Name	Materials	Specification		Remark
			JIS	ASTM	
1	BODY	DUCTILE IRON	FCD 400	A395	(28"~36")
		STAINLESS STEEL	SCS 13A	A351 Gr. CF8	
2	DISC	DUCTILE IRON	FCD 400	A395	Nylon 11 coated
		STAINLESS STEEL	SCS 13A	A351 Gr. CF8	
		STAINLESS STEEL	SCS 14A	A351 Gr. CF8M	
		ALU-BRONZE	ALBC2	B148 C95400	
3	SEAT	NBR (NITRILE)			-10 ° ~ 80 °C (14 ° ~ 176 °F)
		EPDM			-20 ° ~ 120 °C (-4 ° ~ 248 °F)
		EPT			-20 ° ~ 140 °C (-4 ° ~ 284 °F)
		NEOPRENE (CR)			0 ° ~ 80 °C (32 ° ~ 176 °F)
		SILICON			-20 ° ~ 180 °C (-4 ° ~ 356 °F)
		HYPALON (CSM)			-20 ° ~ 135 °C (-4 ° ~ 275 °F)
4	STEM	STAINLESS STEEL	SUS 410	A182 Gr. F6A	
		STAINLESS STEEL	SUS 304	A182 Gr. F304	
		STAINLESS STEEL	SUS 316	A182 Gr. F316	
5	PIN	STAINLESS STEEL	SUS 304	A182 Gr. F304	
6	PLUG	STAINLESS STEEL			
7	O-RING	NBR (NITRILE)			
8	UPPER COVER	STEEL	SS400	A36	For cast iron and ductile iron body
		STAINLESS STEEL	SUS 304	A240 Gr. 304	For stainless steel body
9	BUSH	BRONZE	BC6	B62	For cast iron and ductile iron body
		RTFE+STAINLESS STEEL	RTFE+SUS316	RTFE+A240 Gr. 316	For stainless steel body
10	KEY	STEEL			
11	BOTTOM COVER	CAST IRON	FC 200	A126 Cl. B	For cast iron and ductile iron body
		STAINLESS STEEL	SCS 13A	A351 Gr. CF8	
12	BOLT	STEEL			
13	BOLT	STEEL			



DIMENSIONS RXW WAFER

DN40-DN900 1.5"-36"

PRESSURE RATING

DN40-600 16 BAR 1.5"-24" 232 PSI
DN650-900 10 BAR 26"-36" 150 PSI

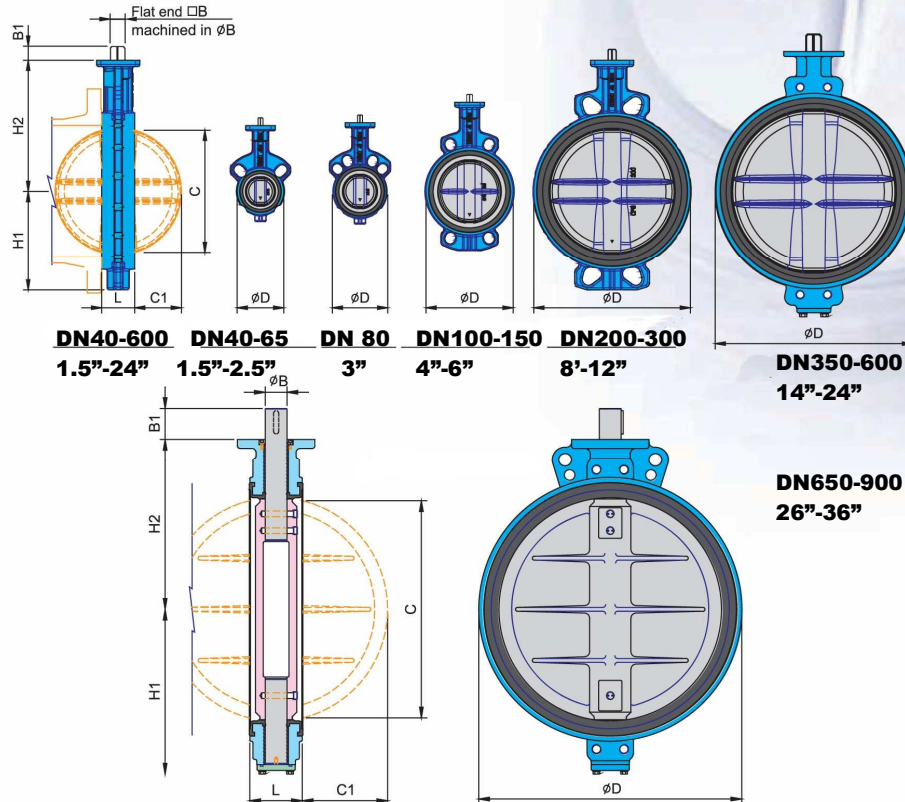

SIZE		Face to face		ISO 5211 Mounting								Shaft end						Key		Disc clearance				
				L		H1		H2		D		Type	PCD		ØB		□B		B1	C		C1		
mm	inch	mm	inch	mm	inch	mm	inch	mm	inch		mm	inch	mm	inch	mm	inch	mm	inch	mm	inch	mm	inch		
40	1.5	33	1.3	60	2.4	0.1	0.0	81	3.2	F07	70	2.8	14	0.6	11	0.4	19	0.7			34	1.3	7	0.3
50	2	43	1.7	65	2.6	143	5.6	96	3.8	F07	70	2.8	14	0.6	11	0.4	19	0.7			39	1.5	8	0.3
65	2.5	46	1.8	71	2.8	155	6.1	110	4.3	F07	70	2.8	14	0.6	11	0.4	19	0.7			55	2.2	13	0.5
80	3	46	1.8	77	3.0	162	6.4	124	4.9	F07	70	2.8	14	0.6	11	0.4	19	0.7			69	2.7	19	0.7
100	4	52	2.0	107	4.2	181	7.1	148	5.8	F07	70	2.8	14	0.6	11	0.4	19	0.7			91	3.6	27	1.1
125	5	56	2.2	122	4.8	197	7.8	180	7.1	F07	70	2.8	18	0.7	14	0.6	19	0.7			115	4.5	36	1.4
150	6	56	2.2	150	5.9	210	8.3	206	8.1	F07	70	2.8	18	0.7	14	0.6	19	0.7			140	5.5	47	1.9
200	8	60	2.4	165	6.5	240	9.4	259	10.2	F10	102	4.0	22	0.9	17	0.7	24	0.9			186	7.3	68	2.7
250	10	68	2.7	201	7.9	286	11.3	320	12.6	F10	102	4.0	25	1.0	19	0.7	24	0.9			239	9.4	90	3.5
300	12	78	3.1	234	9.2	309	12.2	370	14.6	F10	102	4.0	28	1.1	22	0.9	24	0.9			288	11.3	111	4.4
350	14	78	3.1	301	11.9	329	13.0	412	16.2	F12	125	4.9	35	1.4	27	1.1	29	1.1			325	12.8	128	5.0
400	16	102	4.0	333	13.1	361	14.2	475	18.7	F12	125	4.9	35	1.4	27	1.1	29	1.1			375	14.8	143	5.6
450	18	114	4.5	358	14.1	393	15.5	530	20.9	F14	140	5.5	48	1.9	36	1.4	38	1.5			423	16.7	162	6.4
500	20	127	5.0	392	15.4	427	16.8	585	23.0	F14	140	5.5	48	1.9	36	1.4	38	1.5			473	18.6	182	7.2
550	22	154	6.1	397	15.6	475	18.7	635	25.0	F14	140	5.5	50	2.0	36	1.4	38	1.5			507	20.0	186	7.3
600	24	154	6.1	454	17.9	492	19.4	687	27.0	F16	165	6.5	60	2.4	46	1.8	48	1.9			560	22.0	214	8.4
650	26	165	6.5	460	18.1	515	20.3	718	28.3	F16	165	6.5	65	2.6			90	3.5	18X12	68X.47	606	23.9	230	9.1
700	28	165	6.5	508	20.0	563	22.2	796	31.3	F16	165	6.5	70	2.8			110	4.3	20X12	79X.47	655	25.8	255	10.0
750	30	190	7.5	543	21.4	585	23.0	856	33.7	F25	254	10.0	75	3.0			110	4.3	18X12	68X.47	692	27.2	264	10.4
800	32	190	7.5	592	23.3	630	24.8	870	34.3	F25	254	10.0	80	3.1			110	4.3	24X16	98X.60	736	29.0	285	11.2
900	36	203	8.0	632	24.9	660	26.0	1003	39.5	F25	254	10.0	85	3.3			110	4.3	24X16	98X.60	841	33.1	331	13.0



DIMENSIONS RXL LUG DN40-DN600 1.5"-24"

PRESSURE RATING
DN40-600 16 BAR 1.5"-24" 232 PSI

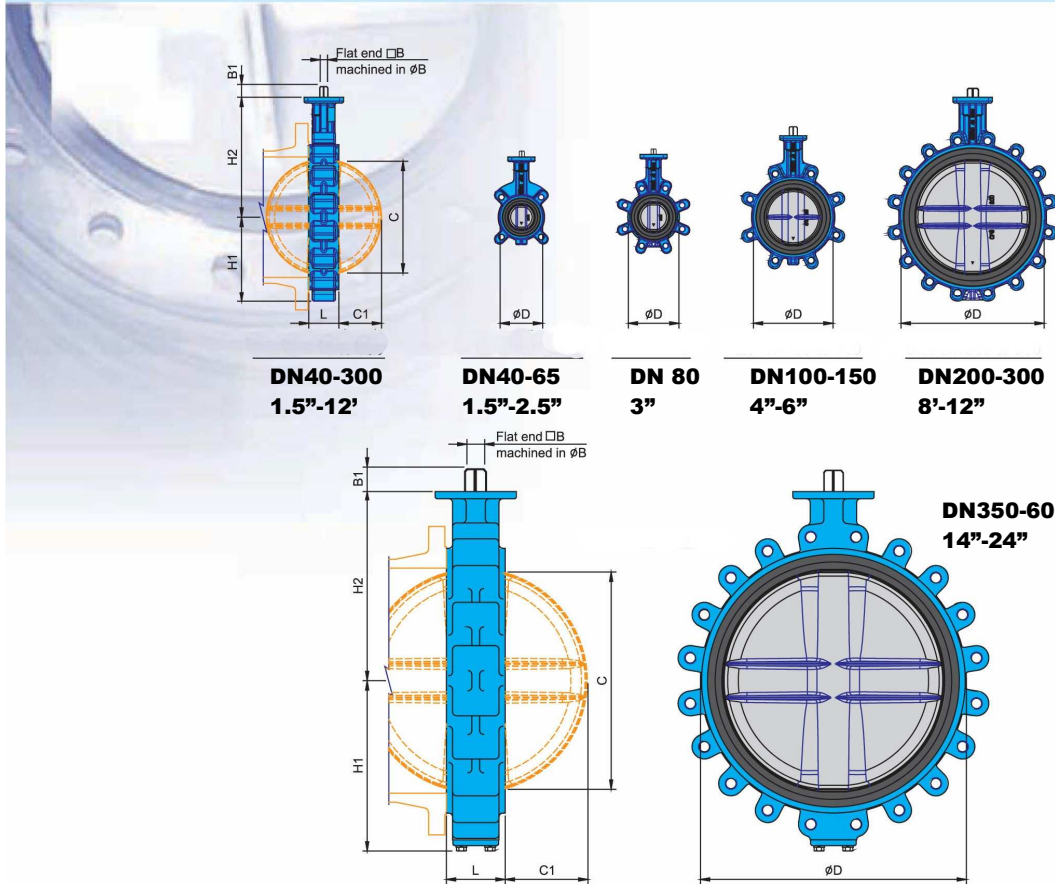

DN40-300
1.5"-12"

DN40-65
1.5"-2.5"

DN 80
3"

DN100-150
4"-6"

DN200-300
8'-12"

DN350-600
14"-24"

SIZE		Face to face		ISO 5211 Mounting						Shaft end						Disc clearance						
				L		H1		H2		D		Type	PCD		ØB		□B	B1		C		C1
mm	inch	mm	inch	mm	inch	mm	inch	mm	inch		mm	inch	mm	inch	mm	inch	mm	inch	mm	inch	mm	inch
40	1.5	33	1.3	60	2.4	120	4.7	81	3.2	F07	70	2.8	14	0.6	11	0.4	19	0.7	34	1.3	7	0.3
50	2	43	1.7	65	2.6	143	5.6	96	3.8	F07	70	2.8	14	0.6	11	0.4	19	0.7	39	1.5	8	0.3
65	2.5	46	1.8	71	2.8	155	6.1	110	4.3	F07	70	2.8	14	0.6	11	0.4	19	0.7	55	2.2	13	0.5
80	3	46	1.8	77	3.0	162	6.4	124	4.9	F07	70	2.8	14	0.6	11	0.4	19	0.7	69	2.7	19	0.7
100	4	52	2.0	107	4.2	181	7.1	148	5.8	F07	70	2.8	14	0.6	11	0.4	19	0.7	91	3.6	27	1.1
125	5	56	2.2	122	4.8	197	7.8	180	7.1	F07	70	2.8	18	0.7	14	0.6	19	0.7	115	4.5	36	1.4
150	6	56	2.2	150	5.9	210	8.3	206	8.1	F07	70	2.8	18	0.7	14	0.6	19	0.7	140	5.5	47	1.9
200	8	60	2.4	165	6.5	240	9.4	259	10.2	F10	102	4.0	22	0.9	17	0.7	24	0.9	186	7.3	68	2.7
250	10	68	2.7	201	7.9	286	11.3	320	12.6	F10	102	4.0	25	1.0	19	0.7	24	0.9	239	9.4	90	3.5
300	12	78	3.1	234	9.2	309	12.2	370	14.6	F10	102	4.0	28	1.1	22	0.9	24	0.9	288	11.3	111	4.4
350	14	78	3.1	301	11.9	329	13.0	412	16.2	F12	125	4.9	35	1.4	27	1.1	29	1.1	325	12.8	128	5.0
400	16	102	4.0	333	13.1	361	14.2	475	18.7	F12	125	4.9	35	1.4	27	1.1	29	1.1	375	14.8	143	5.6
450	18	114	4.5	358	14.1	393	15.5	530	20.9	F14	140	5.5	48	1.9	36	1.4	38	1.5	423	16.7	162	6.4
500	20	127	5.0	392	15.4	427	16.8	585	23.0	F14	140	5.5	48	1.9	36	1.4	38	1.5	473	18.6	182	7.2
550	22	154	6.1	397	15.6	475	18.7	635	25.0	F14	140	5.5	50	2.0	36	1.4	38	1.5	507	20.0	186	7.3
600	24	154	6.1	454	17.9	492	19.4	687	27.0	F16	165	6.5	60	2.4	46	1.8	48	1.9	560	22.0	214	8.4



DIMENSIONS RXF FLANGE DN350-DN1200 14'-48'

PRESSURE RATING
DN350-600 16 BAR 14"-24" 232 PSI
DN650-1200 10 BAR 26"-48" 150 PSI

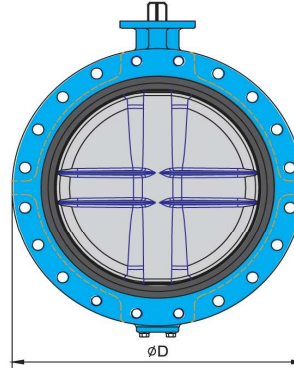
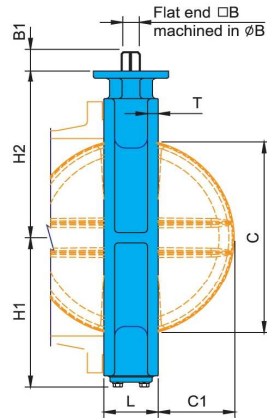

**DN350-600
14"-24"**

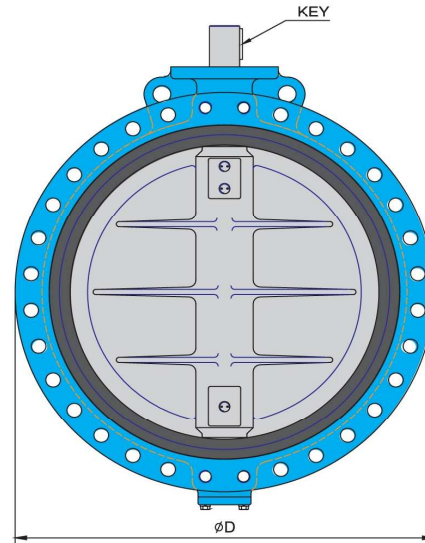
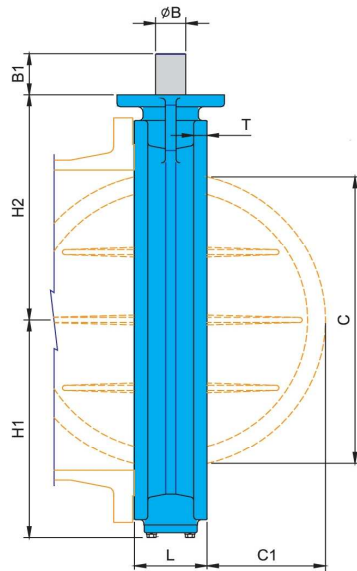

**DN650-1200
26"-48"**

SIZE		Face to face		ISO 5211 Mounting						Shaft end				Key		Disc clearance								
		L		H1		H2		D		Type	PCD		ØB		□B	B1	C		C1					
mm	inch	mm	inch	mm	inch	mm	inch	mm	inch		mm	inch	mm	inch	mm	inch	mm	inch	mm	inch				
350	14	78	3.1	303	11.9	329	13.0	535	21.1	F12	125	4.9	35	1.4	27	1.1	29	1.1			325	12.8	128	5.0
400	16	102	4.0	335	13.2	361	14.2	600	23.6	F12	125	4.9	35	1.4	27	1.1	29	1.1			375	14.8	143	5.6
450	18	114	4.5	363	14.3	393	15.5	648	25.5	F14	140	5.5	48	1.9	36	1.4	38	1.5			423	16.7	162	6.4
500	20	127	5.0	397	15.6	427	16.8	715	28.1	F14	140	5.5	48	1.9	36	1.4	38	1.5			473	18.6	182	7.2
550	22	154	6.1	426	16.8	475	18.7	762	30.0	F14	140	5.5	50	2.0	36	1.4	38	1.5			507	20.0	186	7.3
600	24	154	6.1	454	17.9	492	19.4	840	33.1	F16	165	6.5	60	2.4	46	1.8	48	1.9			560	22.0	214	8.4
650	26	165	6.5	460	18.1	515	20.3	870	34.3	F16	165	6.5	65	2.6			90	3.5	18X12	.68X.47	606	23.9	230	9.1
700	28	165	6.5	508	20.0	563	22.2	927	36.5	F16	165	6.5	70	2.8			110	4.3	20X12	.79X.47	655	25.8	255	10.0
750	30	190	7.5	543	21.4	585	23.0	997	39.3	F25	254	10.0	75	3.0			110	4.3	18X12	.68X.47	692	27.2	264	10.4
800	32	190	7.5	592	23.3	630	24.8	1060	41.7	F25	254	10.0	80	3.1			110	4.3	24X16	.98X.60	736	29.0	285	11.2
900	36	203	8.0	632	24.9	660	26.0	1170	46.1	F25	254	10.0	85	3.3			110	4.3	24X16	.98X.60	841	33.1	331	13.0
950	38	216	8.5	682	26.9	729	28.7	1238	48.7	F25	254	10.0	95	3.7			110	4.3	28X16	1.1X.60	899	35.0	350	13.8
1000	40	216	8.5	698	27.5	749	29.5	1289	50.7	F30	298	11.7	100	3.9			155	6.1	28X16	1.1X.60	941	37.0	373	14.7
1050	42	216	8.5	761	30.0	813	32.0	1340	52.8	F30	298	11.7	100	3.9			180	7.1	28X16	1.1X.60	977	38.5	391	15.4
1100	44	216	8.5	768	30.2	814	32.0	1403	55.2	F30	298	11.7	110	4.3			180	7.1	32X18	1.3X.71	1024	40.3	414	16.3
1200	48	254	10.0	814	32.0	870	34.3	1511	59.5	F30	298	11.7	110	4.3			180	7.1	32X18	1.3X.71	1131	44.5	451	17.8



LEVER & GEAR OPERATED

**RXW Wafer
RXL Lug
RXF Flange**

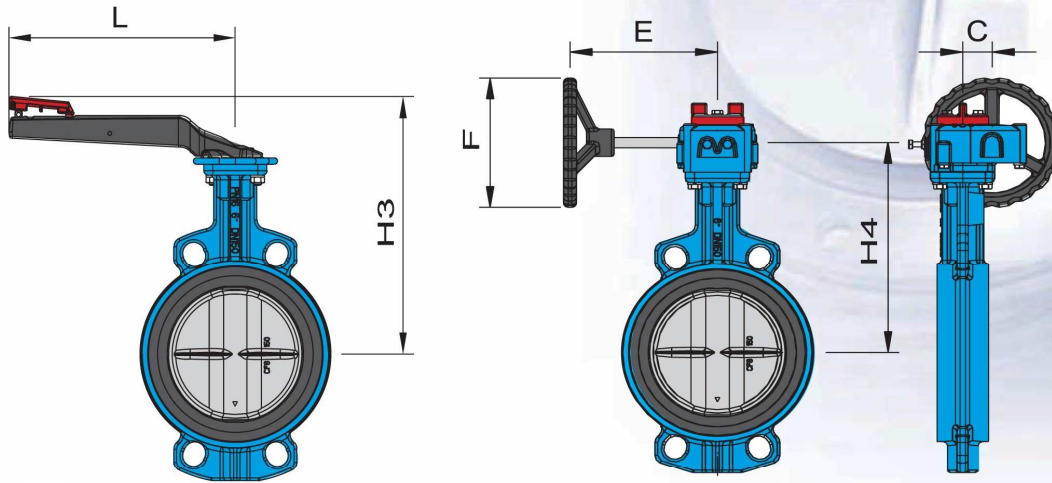

SIZE		Lever Operator				Gear operator						ISO Mounting				
		H3		L		H4		C		E		F		Type	PCD	
mm	inch	mm	inch	mm	inch	mm	inch	mm	inch	mm	inch	mm	inch		mm	inch
40	1.5	195	7.7	200	7.9	157	6.2	41	1.6	155	6.1	150	5.9	F07	70	2.8
50	2	218	8.6	200	7.9	180	7.1	41	1.6	155	6.1	150	5.9	F07	70	2.8
65	2.5	230	9.1	200	7.9	192	7.6	41	1.6	155	6.1	150	5.9	F07	70	2.8
80	3	237	9.3	200	7.9	199	7.8	41	1.6	155	6.1	150	5.9	F07	70	2.8
100	4	256	10.1	200	7.9	218	8.6	41	1.6	155	6.1	150	5.9	F07	70	2.8
125	5	272	10.7	250	9.8	234	9.2	41	1.6	155	6.1	150	5.9	F07	70	2.8
150	6	285	11.2	250	9.8	247	9.7	41	1.6	155	6.1	150	5.9	F07	70	2.8
200	8	324	12.8	355	14.0	281	11.1	63	2.5	195	7.9	200	7.9	F10	102	4.0
250	10	370	14.6	355	14.0	327	12.9	63	2.5	195	7.9	200	7.9	F10	102	4.0
300	12	393	15.5	355	14.0	350	13.8	63	2.5	195	7.9	200	7.9	F10	102	4.0
350	14				0.0	370	14.6	61	2.4	255	12.2	310	12.2	F12	125	4.9
400	16				0.0	402	15.8	61	2.4	255	12.2	310	12.2	F12	125	4.9
450	18				0.0	445	17.5	81	3.2	340	12.2	310	12.2	F14	140	5.5
500	20				0.0	479	18.9	81	3.2	340	15.7	400	15.7	F14	140	5.5
550	22				0.0	527	20.7	81	3.2	340	15.7	400	15.7	F14	140	5.5
600	24				0.0	548	21.6	123	4.8	307	15.7	400	15.7	F16	165	6.5
650	26				0.0	571	22.5	160	6.3	307	15.7	400	15.7	F16	165	6.5
700	28				0.0	619	24.4	123	4.8	307	15.7	400	15.7	F16	165	6.5
750	30				0.0	730	28.7	160	6.3	370	15.7	400	15.7	F25	254	10.0
800	32				0.0	775	30.5	160	6.3	370	15.7	400	15.7	F25	254	10.0
900	36				0.0	805	31.7	160	6.3	370	15.7	400	15.7	F25	254	10.0
950	38				0.0	874	34.4	160	6.3	370	15.7	400	15.7	F25	254	10.0
1000	40				0.0	945	37.2	197	7.8	471	23.6	600	23.6	F30	298	11.7
1050	42				0.0	1009	39.7	197	7.8	471	23.6	600	23.6	F30	298	11.7
1100	44				0.0	1010	39.8	197	7.8	471	23.6	600	23.6	F30	298	11.7
1200	48				0.0	1066	42.0	197	7.8	471	23.6	600	23.6	F30	298	11.7

INVESTMENT CASTING STAINLESS STEEL BODY



PRESSURE RATING
DN40-600 16 BAR
1.5"-24" 232 PSI

Flowserve Corp. offers a new line of butterfly valves with stainless steel **investment cast bodies(1) and discs(2)** from size DN40 up to DN300(12") in both wafer and lug styles. This line of valves has the same design features of model - RX valve, plus the advantage parts like **RTFE+SS316 bushings(8)**, stem retainer (9), stainless steel lever operator set and gear box etc., to reach a high integrity corrosion resistance exterior for use in aggressive environment.

Anti static device (10.11) has to be equipped with this valve, since the valve disc & stem was isolated by rubber liner and stem bushings. It will collect the static, which resulted by the friction between the fluids and disc. In order to prevent the dangers caused by static, the antistatic device is required.

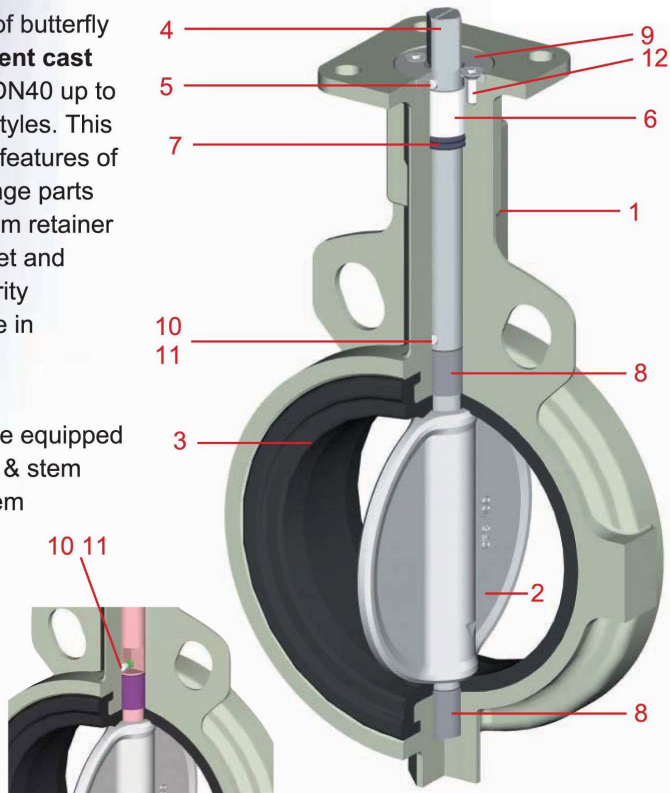

No.	Name	Materials	Specification		Remark
			JIS	ASTM	
1	BODY	STAINLESS STEEL	SCS 13A	A351 Gr. CF8	
			SCS 14A	A351 Gr. CF8M	
2	DISC	STAINLESS STEEL	SCS 13A	A351 Gr. CF8	
			SCS 14A	A351 Gr. CF8M	
3	SEAT	NBR (NITRILE)			-10° ~ 80°C (14° ~ 176°F)
		EPDM			-20° ~ 120°C (-4° ~ 248°F)
		EPT			-20° ~ 140°C (-4° ~ 284°F)
		NEOPRENE (CR)			0° ~ 80°C (32° ~ 176°F)
		SILICON			-20° ~ 180°C (-4° ~ 356°F)
		HYPALON (CSM)			-20° ~ 135°C (-4° ~ 275°F)
		VITON			-18° ~ 204°C (-0.4° ~ 400°F)
4	STEM	STAINLESS STEEL	SUS 410	A182 Gr. F6A	
			SUS 304	A182 Gr. F304	
			SUS 316	A182 Gr. F316	
			SUS 304	A182 Gr. F304	
5	PIN	STAINLESS STEEL	SUS 304	A182 Gr. F304	
6	BUSH	DELTRIN			
7	O-RING	NBR (NITRILE)			
8	BUSH	RTFE+STAINLESS STEEL	RTFE+SUS 316	RTFE+A240 Gr. 316	
9	STEM RETAINER	STAINLESS STEEL	SUS 304	A240 Gr. F304	
10	PIN (ANTI-STATIC)	STAINLESS STEEL	SUS 304	A182 Gr. F316	
11	SPRING	STAINLESS STEEL	SUS 304	A182 Gr. F304	
12	SCREW	STAINLESS STEEL	SUS 304	A193 Gr. B8	



INVESTMENT CASTING STAINLESS STEEL BODY

PRESSURE RATING
DN40-600 16 BAR
1.5"-24" 232 PSI

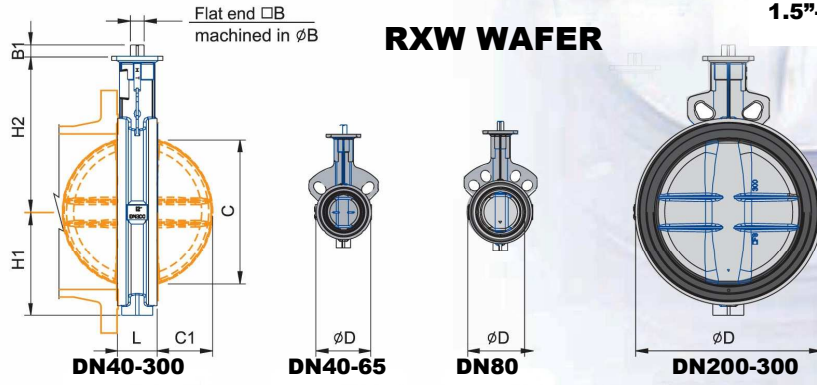

RXW WAFER

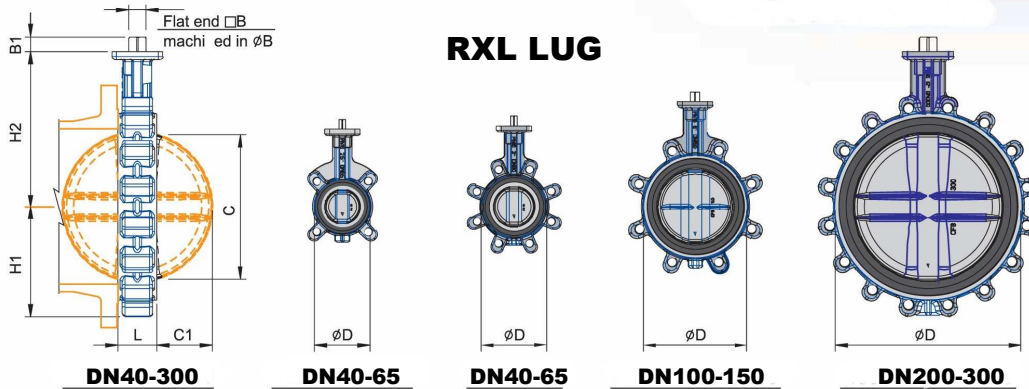

RXL LUG

SIZE		Face to face								ISO 5211 Mounting				Shaft end				Disc clearance				
		L		H1		H2		D		Type	PCD		øB		□B		B1		C		C1	
mm	inch	mm	inch	mm	inch	mm	inch	mm	inch		mm	inch	mm	inch	mm	inch	mm	inch	mm	inch	mm	inch
40	1.5	33	1.3	60	2.4	120	4.7	81	3.2	F07	70	2.8	14	0.6	11	0.4	19	0.7	34	1.3	7	0.3
50	2	43	1.7	65	2.6	143	5.6	96	3.8	F07	70	2.8	14	0.6	11	0.4	19	0.7	39	1.5	8	0.3
65	2.5	48	1.8	71	2.8	155	6.1	110	4.3	F07	70	2.8	14	0.6	11	0.4	19	0.7	55	2.2	13	0.5
80	3	46	1.8	77	3.0	162	6.4	126	5.0	F07	70	2.8	14	0.6	11	0.4	19	0.7	69	2.7	19	0.7
100	4	52	2.0	91	3.6	181	7.1	148	5.8	F07	70	2.8	14	0.6	11	0.4	19	0.7	91	3.6	27	1.1
125	5	56	2.2	103	4.1	197	7.8	180	7.1	F07	70	2.8	18	0.7	14	0.6	19	0.7	115	4.5	36	1.4
150	6	56	2.2	120	4.7	210	8.3	206	8.1	F07	70	2.8	18	0.7	14	0.6	19	0.7	140	5.5	47	1.9
200	8	60	2.4	144	5.7	240	9.4	259	10.2	F10	102	4.0	22	0.9	17	0.7	24	0.9	186	7.3	68	2.7
250	10	68	2.7	174	6.9	288	11.3	325	12.8	F10	102	4.0	25	1.0	19	0.7	24	0.9	239	9.4	90	3.5
300	12	78	3.1	206	8.1	311	12.2	373	14.7	F10	102	4.0	28	1.1	22	0.9	24	0.9	288	11.3	111	4.4



DESIGN DETAILS AND SPECIFICATIONS

WEIGHTS

CAST IRON OR DUCTILE IRON BODY

SIZE		RXW WAFER		RXL LUG		RXF FLANGE	
mm	inch	kg	pound	kg	pound	kg	pound
40	1.5	2.0	4.4	2.2	4.9		
50	2	3.0	6.6	3.4	7.5		
65	2.5	3.8	8.4	4.0	8.8		
80	3	4.0	8.8	4.5	9.9		
100	4	5.3	11.7	7.6	16.8		
125	5	7.3	16.1	9.5	20.9		
150	6	8.2	18.1	10.4	22.9		
200	8	13.5	29.8	17.5	38.6		
250	10	21.2	46.7	26.5	58.4		
300	12	32.5	71.7	43.5	95.9		
350	14	48	106	58	128	69	152
400	16	60	132	81	179	95	209
450	18	80	176	110	243	129	284
500	20	125	276	155	342	161	355
550	22	130	287	318	701	191	421
600	24	200	441			248	547
650	26	194	428			294	648
700	28	249	549			329	725
750	30	316	697			431	950
800	32	365	805			507	1118
900	36	424	935			621	1369
950	38					750	1653
1000	40					810	1786
1050	42					859	1894
1100	44					931	2053
1200	48					1161	2560

STAINLESS STEEL BODY

SIZE		RXW WAFER		RXL LUG	
mm	inch	kg	pound	kg	pound
40	1.5	2.2	4.9	2.4	5.3
50	2	3.3	7.3	3.7	8.2
65	2.5	4.1	9.0	4.3	9.5
80	3	4.3	9.5	4.9	10.8
100	4	5.7	12.6	8.2	18.1
125	5	7.9	17.4	10.3	22.7
150	6	8.9	19.6	11.3	24.9
200	8	14.6	32.2	18.9	41.7
250	10	22.8	50.3	28.7	63.3
300	12	35.2	77.6	47.1	103.8



TORQUE VALUES FOR FLOWSERVE RX VALVES

LUBRICATING FLUIDS

SIZE		TORQUE @ ΔP 3 bar 45 psi		TORQUE @ ΔP 6 bar 90 psi		TORQUE @ ΔP 10 bar 150 psi		TORQUE @ ΔP16 bar 230 psi	
mm	inches	N-m	in-lb	N-m	in-lb	N-m	in-lb	N-m	in-lb
40	1.5	15	133	17	150	19	168	234	204
50	2	15	133	17	150	19	168	23	204
65	2.5	18	160	20	177	22	195	26	230
80	3	28	248	31	274	34	301	41	363
100	4	37	327	41	363	45	398	54	478
125	5	61	540	68	601	76	673	91	805
150	6	116	1027	127	1124	140	1239	154	1363
200	8	171	1513	190	1681	211	1868	253	2239
250	10	275	2434	306	2708	340	3009	408	3611
300	12	381	3372	423	3744	470	4160	564	4992
350	14	545	4823	605	5355	672	5948		
400	16	728	6443	809	7160	899	7957		
450	18	912	8071	1013	8966	1126	9966		
500	20	1135	10045	1261	11161	1401	12400		
550	22	1373	12152	1525	13497	1695	15002		
600	24	1325	11726	1472	13028	1636	14480		
650	26	1555	13763	1727	15285	1920	16993		
700	28	2339	20700	2599	23003	2888	25561		
750	30	2608	23081	2898	25649	3220	28499		
800	32	3008	26621	3342	29579	3713	32863		
900	36	3928	33878	4253	37642	4726	41829		
950	38	4415	39073	4920	43547	6610	58503		
1000	40	5090	45047	5680	50272	7620	67443		
1050	42	5611	51432	6262	55423	8401	74355		
1100	44	6158	54503	6872	60822	9262	81976		
1200	48	7328	64858	8178	72381	11022	97553		

Dry non-lubricating fluids

SIZE		TORQUE @ ΔP 3 bar 45 psi		TORQUE @ ΔP 6 bar 90 psi		TORQUE @ ΔP 10 bar 150 psi	
mm	inches	N-m	in-lb	N-m	in-lb	N-m	in-lb
40	1.5	19	168	21	186	23	204
50	2	19	168	21	186	23	204
65	2.5	22	195	24	212	27	239
80	3	34	301	38	336	42	372
100	4	45	398	50	443	56	496
125	5	76	673	84	743	93	823
150	6	126	1115	138	1221	152	13456
200	8	211	1868	234	2071	260	2301
250	10	340	3009	378	3346	420	3717
300	12	470	4160	522	4620	580	5133
350	14	672	5948	747	6612	830	7346
400	16	899	7957	999	8842	1110	9824
450	18	1126	9966	1251	11072	1390	12303
500	20	1401	12400	1557	13781	1730	15312
550	22	1695	15002	1884	16675	2093	18525
600	24	1636	14480	1818	16091	2020	17879
650	26	1920	16993	2133	18879	2370	20976
700	28	2888	25561	3209	28402	3566	31562
750	30	3220	28499	3578	31668	3975	35182
800	32	3713	32863	4125	36509	4583	40563
900	36	4726	41829	5251	46475	5834	51635
950	38	5450	48237	6050	53547	7100	62840
1000	40	6280	55583	7010	62043	9410	83286
1050	42	6924	61283	7728	68399	10374	91818
1100	44	7599	67257	8481	75063	11385	100766
1200	48	9043	80037	10093	89331	13548	119910



Kv Cv Values-Valve Sizing Coefficient

Disc angle (Degrees Open)

KV
Cv

SIZE		10°	20°	30°	40°	50°	60°	70°	80°	90°
mm	inches									
40	1.5	0.7	2.4	6.9	14.2	22	36	59	81	113
		0.8	2.8	8.0	16.5	26	42	69	94	131
50	2	1.1	3.8	10.2	22	38	60	100	132	193
		1.3	4.4	11.9	26	44	70	116	153	224
65	2.5	2	7.5	18.2	35	61	95	187	240	315
		2.3	8.7	21.2	41	71	110	217	279	366
80	3	2.5	9.8	26	48	83	126	214	338	425
		2.9	11.4	30	56	96	146	249	393	494
100	4	3.8	14.6	39	72	119	221	361	606	723
		4.4	17.0	45	84	138	257	420	704	840
125	5	6.5	24	62	118	217	394	599	1038	1243
		7.6	28	72	137	252	458	696	1206	1445
150	6	10	41	95	175	326	542	873	1260	1859
		12	48	110	203	379	630	1015	1464	2161
200	8	19	64	165	306	573	995	1567	2310	3124
		22	74	192	356	666	1156	1821	2685	3631
250	10	28	101	245	451	836	1462	2253	3256	4757
		33	117	285	524	972	1699	2619	3784	5529
300	12	34	129	312	615	1137	2125	3248	4991	7058
		40	150	363	715	1322	2470	3775	5801	8204
350	14	47	163	390	795	1498	2573	3980	5749	8319
		55	189	453	924	1741	2991	4626	6682	9669
400	16	62	231	508	1077	1973	3381	5385	8099	11458
		72	268	590	1252	2293	3930	6259	9413	13318
450	18	75	256	621	1208	2315	3925	6331	9474	13612
		87	298	722	1404	2691	4562	7359	11012	15821
500	20	103	346	859	1692	3086	5348	8513	13109	18748
		120	402	998	1967	3587	6216	9895	15237	21791
550	22	125	418	1039	2047	3734	6471	10300	15861	22685
		145	486	1208	2379	4340	7521	11972	18435	26367
600	24	139	494	1153	2389	4466	7561	11945	18088	25217
		162	574	1340	2777	5191	8788	13884	21024	29310
650	26	163	579	1353	2804	5241	8873	14018	21228	29595
		189	673	1573	3259	6092	10313	16293	24673	34398
700	28	191	659	1674	3224	5990	10659	17442	25194	36821
		222	766	1946	3747	6962	12389	20273	29283	42797
750	30	203	700	1777	3420	6354	11307	18503	26727	39062
		236	814	2065	3975	7385	13142	21506	31065	45402
800	32	257	973	2302	4533	8235	14123	23021	31613	45995
		299	1131	2676	5269	9572	16415	26757	36744	53460
900	36	329	1253	2950	5862	10810	18184	29756	42893	61044
		382	1456	3429	6813	12564	21135	34585	49855	70951
950	38	460	1730	4020	7180	12170	19800	32490	40320	62150
		535	2011	4672	8345	14145	23014	37763	46864	72237
1000	40	510	1919	4456	7956	13494	21939	36000	54649	68874
		593	2230	5179	9247	15684	25500	41843	63519	80052
1050	42	562	2116	4913	8771	14877	24188	39690	60251	75934
		653	2459	5710	10195	17292	28114	46132	70030	88258
1100	44	617	2322	5392	9627	16328	26546	43560	66125	83338
		717	2699	6267	11189	18978	30854	50630	76857	96864
1200	48	734	2763	6417	11457	19431	31592	51840	78695	99179
		853	3211	7458	13316	22585	36719	60254	91467	115276

How to Specify RX Butterfly Valves

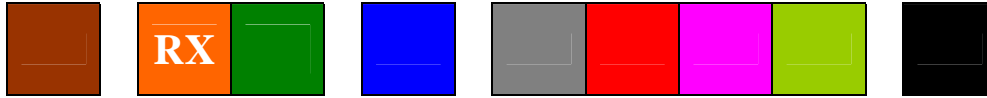

Size Type End Drilling Body Disc Shaft Seat Operator

Example: 8-RXL-1-DD0E-1 shall designate a 8" (200mm) RX centric butterfly valve, lug style, with class 125/150 flange drilling with ductile iron body, Nylon-coated ductile iron disc, 410 SS shaft, EPDM seat, enclosed gear operator

VALVE SIZE	
1.5in (40 mm)	1.5
2 in (50 mm)	2
2,5 in (65 mm)	2.5
3 in (80 mm)	3
4 in (100 mm)	4
5 in (125 mm)	5
6 in (150 mm)	6
8in (200 mm)	8
10 in (250 mm)	10
12 in (300 mm)	12
14 in (350 mm)	14
16 in (400 mm)	16
18 in (450 mm)	18
20 in (500 mm)	20
22 in (550 mm)	22
24 in (600 mm)	24
26 in (650 mm)	26
28 in (700 mm)	28
30 in (750 mm)	30
32 in (800 mm)	32
36 in (900mm)	36
38 in (950m mm)	38
40 in (1000 mm)	40
42 in (1050 mm)	42
44 in (1100 mm)	44
48 in (1200 mm)	48

Type	
RX Centric butterfly valve	RX

End connection	
Lug	L
Wafer	W
Flange	F

Flange drilling	
ASME Class 125/150	1
DIN PN10	2
DIN PN16	5
JIS 10K	J

BODY MATERIAL	
Cast Iron	W
Ductile cast iron	D
304 SS	9
316 SS	1

DISC MATERIAL	
Ductile iron-Nylon coated	D
304 SS	9
316 SS	1
Aluminum bronze	Y
Super Duplex SS	M
Ductile iron-Halar coated	H

SHAFT MATERIAL	
410 SS	0
304 SS	9
316 SS	S

SEAT MATERIAL	
NBR (Nitrile/Buna N)	A
EPDM	E
Hypalon (CSM)	H
Silicone	R
Viton	V
Neoprene (CR)	N
EPT	F

OPERATOR	
standard wrench	0
gear operator	1
Bare Stem	9

Temperature guide

NBR (Nitrile)	14°F - 176°F	-10°C - 80°C
EPDM	-4°F - 248°F	-20°C - 120°C
Hypalon (CSM)	-4°F - 275°F	-20°C - 135°C
Neoprene (CR)	32°F - 176°F	0°C - 80°C
Silicone	-4°F - 356°F	-20°C - 180°C
Viton	0°F - 400°F	-18°C - 204°C
EPT	-4°F - 284°F	-20°C - 140°C



RX AUTOMATED SYSTEMS



Flowserve offers the full range of Automax actuators and instrumentation allowing us to supply complete automated on-off or modulating packages to suit exacting technical requirements. Flowserve's broad line of actuators includes:

- Rack and pinion
- Heavy duty
- Electric actuators.

In addition, Flowserve offers a comprehensive line of engineered special control circuits, solenoid valves, limit switches, positioners, and actuator mounting kits.

Our wide range of electrical and pneumatic instrumentation incorporates:

- Digital network communication
- Superior diagnostics
- intelligent valve controllers
- Comprehensive user-friendly software

Flowserve RX valves have mounting pads designed to ISO 5211 in order to allow you to close-couple mount Automax actuators to the valve

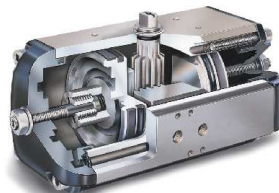

While the information and specifications contained in this literature are believed to be accurate they are supplied for informative purposes only and should not be considered certified or as a guarantee of satisfactory results by reliance thereon. Nothing contained herein is to be construed as a warranty or guarantee, express or implied, regarding any matter with respect to this product. Because Flowserve is continually improving and upgrading its product design, the specifications, dimensions and information contained herein are subject to change without notice. Should any question arise concerning these provisions, the purchaser/user should contact Flowserve Corporation at any of its worldwide operations or offices.

Flowserve Corporation – 1978 Foreman Drive, Cookeville, TN 38502 931-432-4021

To find your local Flowserve representative, visit www.Flowserve.com or call 1-800-25--6761 (USA), 49-2561-6860 (Germany), 65-862 3332 (Singapore), 613-97593300 (Australia), 86-10-59210601(China)

