

Aviator™ Integrated Valve Controller

Introduction:

The Aviator™ integrated valve controller combines an internal solenoid pilot, an external high capacity spool valve and a pair of valve indicating limit switches in one enclosure for maximum corrosion protection. It meets UL and cUL Nema 4, 4X, 7 and 9 waterproof and explosion proof standards. The integral switches and solenoid are pre-wired to a printed circuit board which provides screw terminal connectors for easy external wiring. The Aviator™ housing includes three 1/2" NPT conduit connections for field wiring flexibility. Housings have been designed for easy up-grade to fieldbus communication protocols: upgrading is achieved simply by changing circuit boards and shaft assemblies.

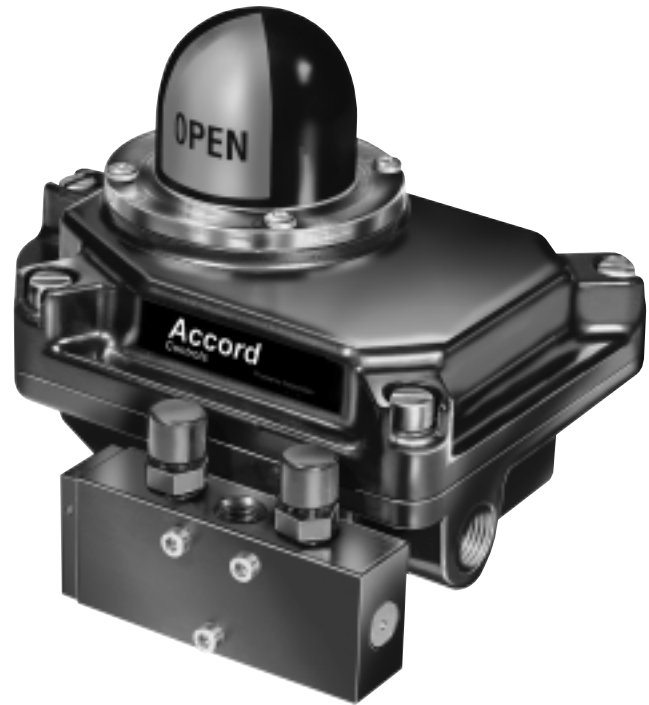

Applications:

The Aviator™ package is designed to meet corrosive, hazardous location valve controls and position signaling needs. Many switch options are available to meet a wide range of electrical specifications. Solenoid options include 3- and 4-way configurations, with standard 120 VAC, 220 VAC, 12 VDC, 24 VDC 2 Watt coils and other low-power coil options available.

Durable construction and corrosion resistant materials and coatings provide protection against the toughest applications in all process industries including:

1. Chemical and petro-chemical
2. Power
3. Food and Beverage
4. Pharmaceutical
5. Municipal and Waste Water

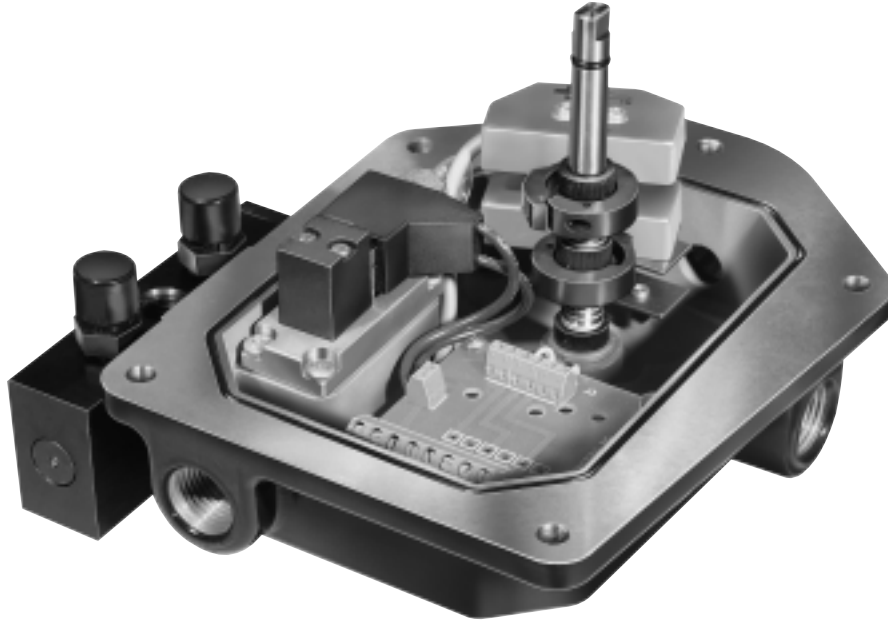

Features:

1. **Internal Pilot Solenoid Coil** contains and protects the coil within the Aviator housing. This feature allows for secure operation in hazardous environments, eliminates expensive explosion proof conduit and fittings, simplifies wiring, and reduces the time and expense of installation. This feature also offers a high degree of solenoid coil protection in difficult "wash down" applications.
2. **Quick-Set Cams.** Tool free adjustment of switch trip point is accomplished simply by pushing or pulling the cam and rotating it to the new trip point position. Cams are spring-loaded and splined to maintain switch settings in any installed position. They are fully adjustable through 360° in 4° increments.
3. **Corrosion Resistant Materials.** All exposed parts are either stainless steel, anodized aluminum, or aluminum treated with Dichromate undercoat and polyester electrostatic powder top coat to enhance protection in corrosive environments. A food grade epoxy coating is also available.
4. **Captive Cover Screws** permit calibration without potential for losing screws.
5. **Ultradome™ Visual Position Indicator** provides adjustable, high-contrast, full-angle viewing of valve position.
6. **Fieldbus upgradeable.** Fieldbus digital communications will become a common requirement in the near future. The Aviator™ housing has been designed to accommodate circuitry necessary to communicate with these systems and may be field-upgraded to expand installed units' capabilities.

Accord Controls
A Unit of Flowserve Corporation

765 South 100 East
Provo, Utah 84606

Phone: 801 373 4576
Facsimile: 801 489 2591
www.accord-controls.com

Materials of Construction:

Part	Materials
Housing/Cover	Aluminum w/Dichromate/Powdercoat
Shaft	Stainless Steel
Cams/Splines	Nylon
UltraDome Dome and Rotor	Polycarbonate
Terminal Block	Phoenix PCB Screw terminals
Internal Brackets	Stainless Steel or Plated Carbon Steel
All Internal Fasteners	Stainless Steel or Plated Carbon Steel
All External Fasteners	Stainless Steel

Dimensions:

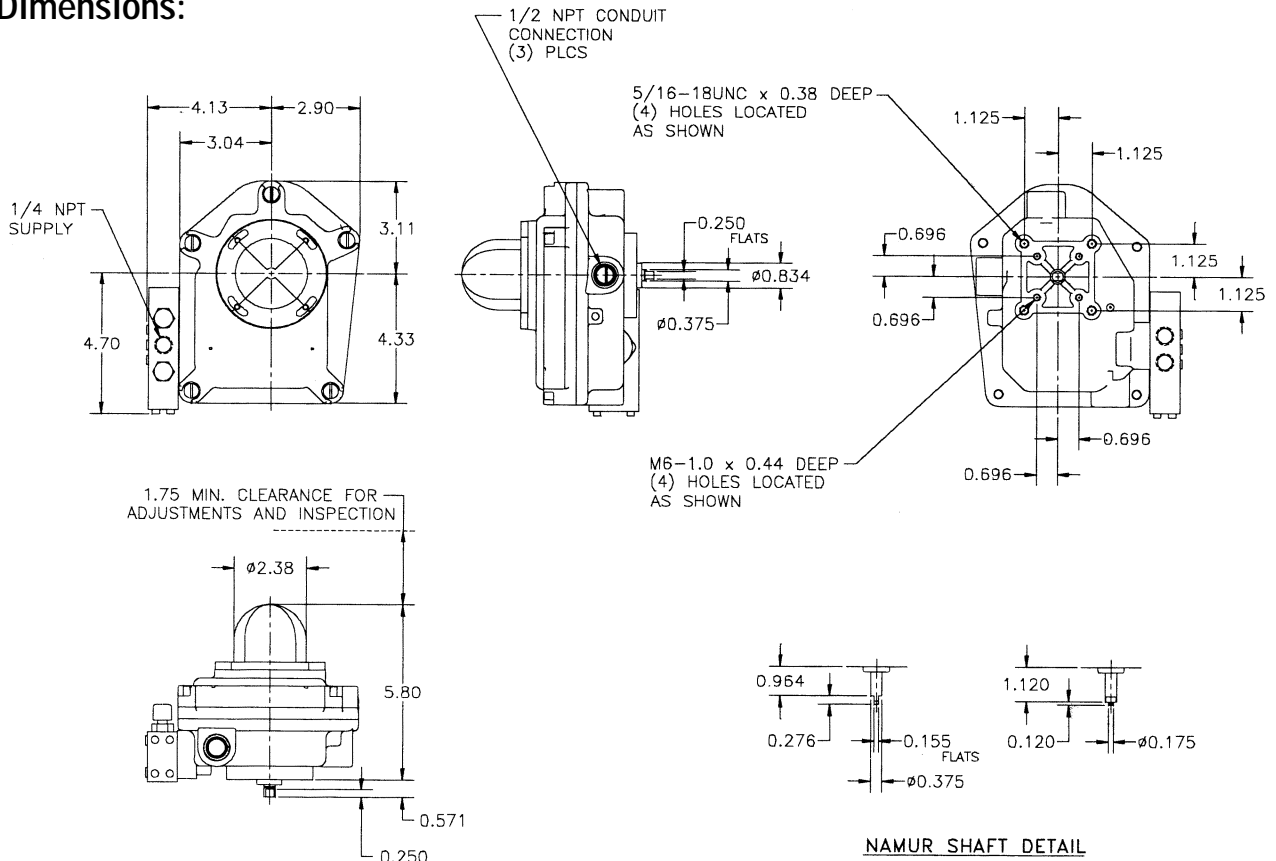

Principles of Operation:

The Aviator™ is designed for use with pneumatic rotary industrial valve actuators in hazardous locations. It provides actuator/valve control by receiving a direct solenoid voltage signal. It also provides remote indication of open and closed valve positions by completing separate electrical circuits. Local visual indication is accomplished with the UltraDome rotary indicator.

Enclosure Ratings:

NEMA 4, 4X, 7, and 9

Mechanical Switches

Types M1 & MG
Class I, Groups C & D
Divisions 1 & 2
Class II Groups E, F, & G
Divisions 1 & 2

Proximity Switches

Types P1, P2, PP, PK, PL, PM, B4, BL, BK, BM
Class I, Groups C & D
Divisions 1 & 2
Class II, Groups E, F, & G
Divisions 1 & 2
Class I, Groups A & B
Division 2 only

Note: When using hermetically sealed proximity switches in Division 2 hazardous locations, a conduit seal is not required.

Temperature Range

Hazardous Locations: T6: -13 to 133 Deg. F (-25 to 56 Deg. C)
T5: -13 to 160 Deg. F (-25 to 71 Deg. C)
T4A: -13 to 176 Deg. F (-25 to 80 Deg. C)

Agency Listings

UL and cUL file number E122717.

Representative: