

## ***Logix™ A500 Digital Positioner***

### **Introduction:**

The Logix™ A500 Series digital positioner provides highly accurate positioning and very responsive control of quarter turn valves and dampers. The Logix™ A510 positioner is available as a 4-20mA I/P digital positioner. The Logix™ A520 is a simple to use, full featured HART digital positioner. Utilizing industry standard HART protocol, the Logix A520 provides a wealth of information and functionality to the user, including dual gain tuning, 21-point characterization, and signatures for diagnostic purposes and accuracy measurements.



### **Applications:**

The Logix™ A500 digital positioner combines state-of-the-art piezo valve technology with inner-loop feedback. High performance control combined with minimal air consumption makes it suitable for use in precise pneumatic actuator control applications including: Rack and Pinion, Scotch-Yoke, Vane, and Linear actuators.

The Logix™ A500 is provided with NAMUR VDI/VDE mounting interfaces for direct mounting to linear or rotary actuators. The spring-loaded shaft takes up the deadband for highly accurate control. The positioner is ideally suited for both rotary or linear actuator applications, with mounting kits available for each.

The Logix™ A500 is constructed from durable cast aluminum and treated with an anodized undercoat and powder topcoat for protection against the toughest applications in all process industries including:

1. Chemical and Petro-Chemical
2. Power
3. Food and Beverage
4. Pharmaceutical
5. Municipal
6. Wastewater Treatment



## Features:

1. **Quick-Cal™** function provides fast, push-button automatic commissioning of positioner. The **Direct User Interface** allows local access to positioner control without requiring multi-level menus, a handheld communicator or laptop computer.
2. **Two-Stage Control** to provide faster response and tighter control. State-of-the-art piezo technology combined with inner-loop feedback provides high performance with minimal air consumption.
3. Using **HART Protocol**, the Logix™ A520 can use existing handheld communicators and supply extensive information. SoftTools™ software allows the operator to run diagnostics and signatures, calibrate, display parameters, log data, set alarms, and perform many other functions in a familiar Windows environment with on-line help files.
4. **21-Point Custom Characterization** allows the valve to be in virtually any position the operator desires for a given signal.
5. **Local Status LEDs** provide operators with a window into the system, alerting personnel to potential problems. The LEDs provide instant information relating to internal diagnostic codes, indicating 36 different conditions. These codes indicate positioner status and alarms without the need for a handheld communicator or laptop computer.
6. The **Jog Calibrate** function allows the user to quickly and easily calibrate the positioner on all actuators without physical stroke stops.
7. **Auto Tune Function.** A simple press of a button starts the self-calibration and auto tune process, reducing commissioning time and ensuring consistency between one valve and the next regardless of who performs the procedure. Additionally, a gain selector switch allows the user to increase or decrease the calculated gain to achieve optimal performance.
8. **NAMUR and VDI/VDE interfaces**, combined with compact and lightweight design, provides direct mounting to various rotary or linear actuators.

Accord Controls  
A Unit of Flowserve Corporation

1350 N. Mountain Springs Parkway  
Springville, Utah 84663-3004

Phone: 801 489 8611  
Facsimile: 801 489 2591

### Materials of Construction:

**Housing:** Die Cast, powder-painted aluminum

**Shaft:** Stainless Steel

**Seals:** Nitrile

### SoftTools™ Software Requirements:

**Minimum 80486 processor, Windows 95 or NT, 16MB total memory (32MB recommended), 20MB available hard disk space.**

### Certification/Listings:

**CENELEC** EEX ia IIC T4/T5/T6

**Factory Mutual and CSA**

Non Incendive - CL I, Div 2, Groups A, B, C, D

Intrinsically Safe - CL I, Div 1, Groups A, B, C, D



### Specifications:

Power Supply	Two-wire, 4-20mA Input
Compliance Voltage	12.6 VDC (HART), 12.2 VDC (analog)
Voltage Supply (max.)	30 VDC
Communications	HART Protocol (520 only)
Minimum Start-up Current	3.6mA
Minimum Operating Current	3.6mA
Supply Air Quality	Free from moisture, oil and dust per ISA-7.0.01
Input Pressure Range	22 to 87psi (1.5 to 6.0 bar)
Air Consumption (steady state)	0.047 SCFM @ 22 psi (0.08 m3/h @ 1.5 bar) 0.071 SCFM @ 87 psi (0.12 m3/h @ 6.0 bar)
Linearity	±1.0% Full Scale
Resolution	0.3% Full Scale
Repeatability	0.3% Full Scale
Hysteresis	0.8% Full Scale
Deadband	0.4% Full Scale
Operating Temperature	Standard -4 to 178F (-20 to 80C) Low -40 to 178F (-40 to 80C)
Weight	2.7 lbs (1.2 kg)

### Dimensions:

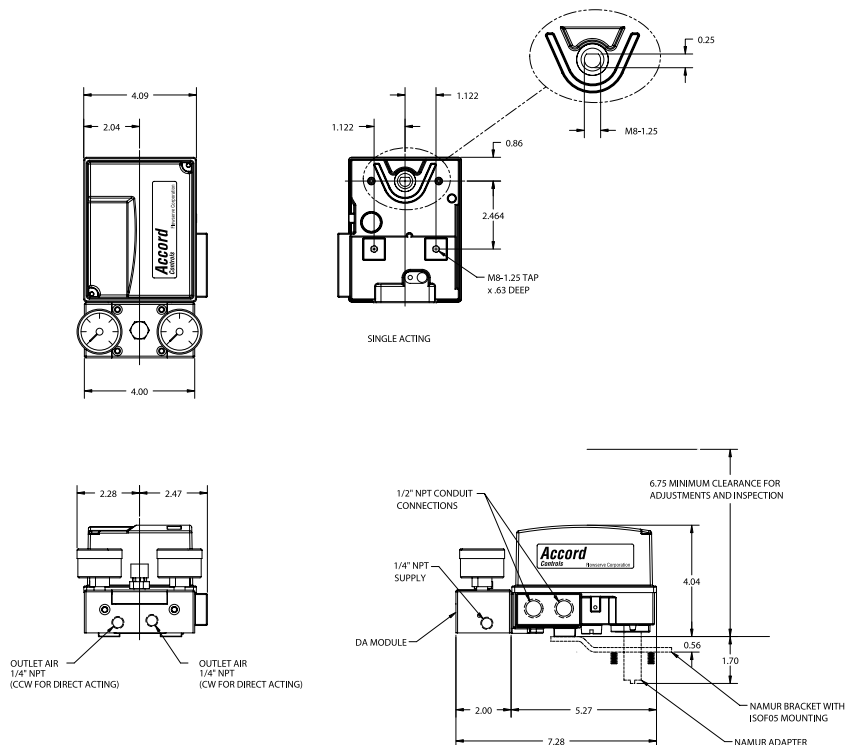

## Principles of Operation:

The Logix™ A520 positioner is a digital positioner that incorporates HART protocol for communication. The positioner consists of three main modules: 1) the microprocessor-based electronic control module (optional HART communications) and direct user interface switches; 2) the piezo valve based electro-pneumatic converter module; and 3) the infinite resolution valve position sensor. The basic positioner operation is best understood by referring to the figure below. The complete control circuit is powered by the 2-wire, 4-20mA command signal. The optional HART module sends and receives the FSK HART digital communications superimposed over the 4-20mA signal wires providing 2-way digital communications to the microprocessor. The analog 4-20mA command is passed to the microprocessor, where it is compared to the measured valve stem position. The control algorithm in the processor performs dual gain control calculations and produces an output command to the analog piezo valve, which drives the pneumatic amplifier. The pilot valve position in the pneumatic amplifier is measured and relayed to the inner-loop control circuit. This 2-stage control provides for more responsive and tighter control than is possible with a single-stage control algorithm. The pneumatic amplifier controls the airflow to the actuator. The change of pressure and volume of the air in the actuator causes the valve to stroke. As the valve approaches the desired position, the difference between the commanded signal and the measured position becomes smaller and the output to the piezo is decreased. This causes the pilot valve to close and the resulting flow to decrease, which slows the actuator movement as it approaches the new commanded position. When the valve actuator is at the desired position, the pneumatic amplifier output is held at zero, which holds the valve in a constant position.

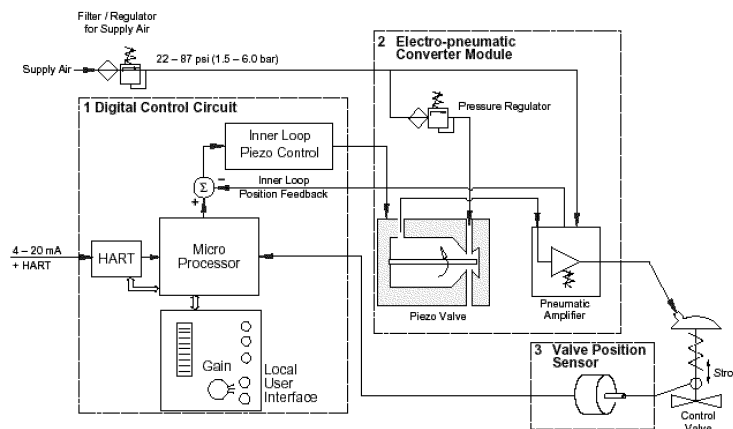

## How to Order:

<b>I. Model</b>		<b>VII. Analog Feedback</b>	
A5	Logix 500 Series Positioner	Blank	None
<b>II. Communication</b>		F	4-20mA Transmitter (Logix 510)
1	4-20mA Analog	<b>VIII. Temperature Options</b>	
2	HART	Blank	Standard -4 to 178F (-20 to 80C)
<b>III. Diagnostics</b>		C	Low Temperature -40 to 178F (-40 to 80C)
0	Standard	<b>IX. Actuator Style</b>	
<b>IV. Certifications</b>		Blank	Linear
02	I.S. CL I, Div 1, Groups A,B,C,D (CSA Pending)	R	Rotary
14	General Purpose	<b>X. Conduit Connections</b>	
15	Intrinsically Safe Cenelec EEx ia IIC ATEX II 1 GD	Blank	1/2" NPT
<b>V. Housing Material</b>		G	PG 13.5
B	Aluminum (black)	M	M20-1.50
<b>VI. Feedback Options</b>		<b>XI. Gauge Options</b>	
Blank	None	K1	None
N	P+F S.J3.5N	K2	Standard Gauges
S	P+F S.J3.5SN	K3	SST Gauges
T	Turck Si3.5K-Y10	<b>XII. Action</b>	
		Blank	Single Acting
		D	Double Acting

Example: A520-02-BRK2D = Accord Logix 520 positioner with HART protocol, Intrinsically Safe approval, Black aluminum enclosure, rotary applications, standard gauges, and DA Module.