

ISC

**ISC2SS
Dual Stationary Bellows Seal**

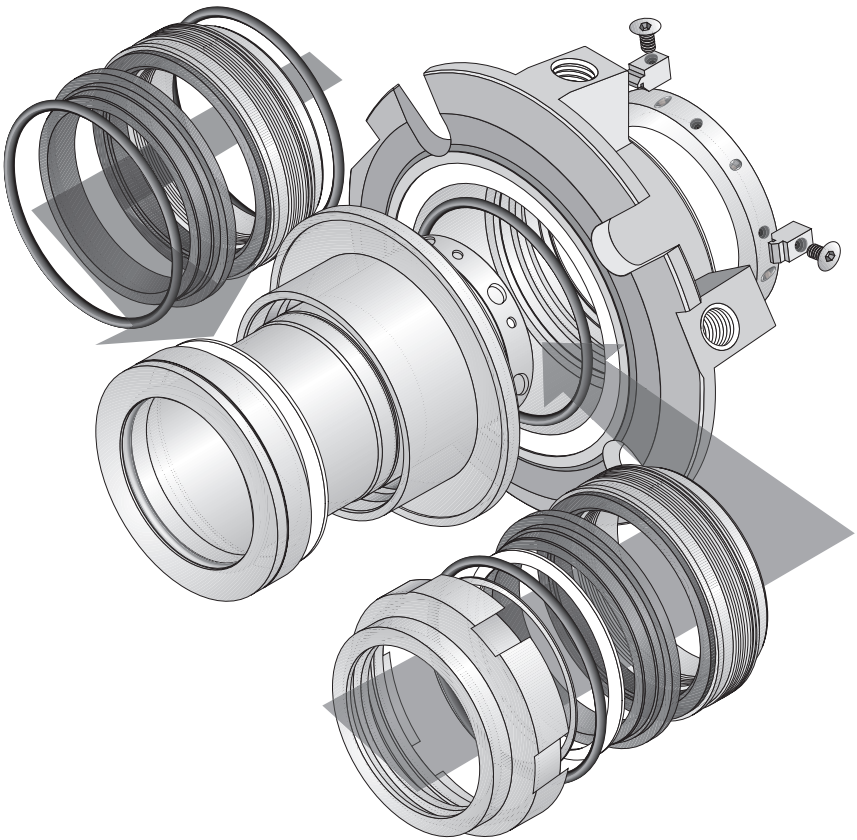

Repair Instructions

These instructions are written for trained, experienced technicians familiar with the basic principles and tools involved in the installation, care and service of mechanical seals and seal support systems. A complete reading of these instructions by personnel in contact with the equipment is essential to safety. Incorrect installation, operation or maintenance can result in personal injury or death to personnel and damage to the equipment.

1 Nomenclature

Figure 1

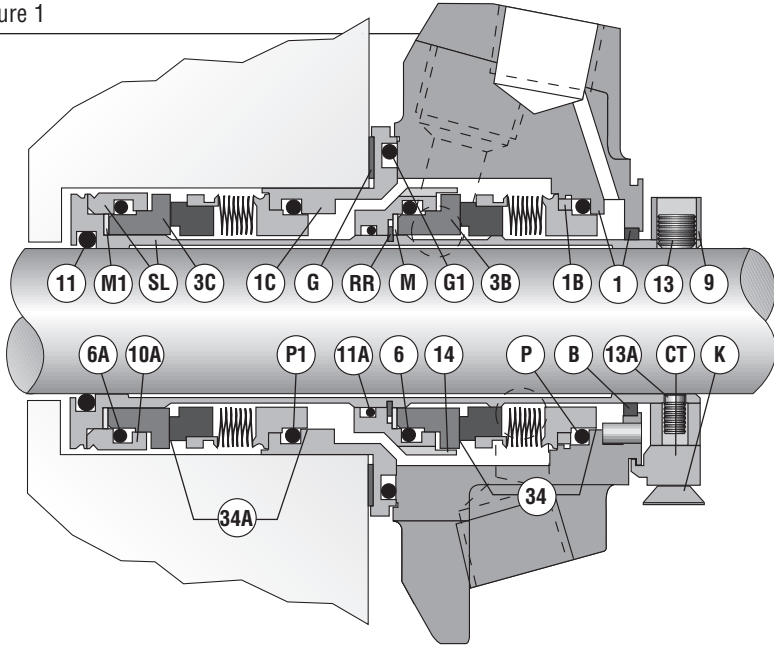

- Notes:**
- Inboard bellows assembly (34A) is interchangeable with outboard bellows assembly (34).
 - Inboard mating ring (3C) is interchangeable with outboard mating ring (3B).
 - Primary seal O-rings (P, P1, 6, 6A) are all the same size and cross section.

Table 1

34	Outboard Bellows Assembly	14	Rotor Carrier
34A	Inboard Bellows Assembly	RR	Retaining Ring
3B	Outboard Mating Ring	CT	Centering Tab
3C	Inboard Mating Ring	K	Centering Tab Cap Screw
6	Outboard Mating Ring O-ring	SL	Sleeve Assembly
6A	Inboard Mating Ring O-ring	10A	Drive Ring
P	Outboard Bellows O-ring	M	Outboard Vibration Dampener
P1	Inboard Bellows O-ring	M1	Inboard Vibration Dampener
G	Gasket	9	Sleeve Collar
G1	Inner Gland O-ring	13	Cup Point Set Screw
1	Gland Assembly	13A	Quarter Dog Set Screw
B	Carbon Bushing	11	Sleeve O-ring
1B	Gland Drive Ring	11A	Rotor Carrier O-ring
1C	Inner Gland		

2 Disassembly

When disassembling seal, inspect for conditions which may have caused the need for the seal to be removed from service. If seal was removed due to premature failure, determine what conditions caused that failure and correct any problems prior to returning the repaired seal to service. For assistance with seal failure analysis, please contact your Flowserve representative.

Seal Parts that are always replaced

- Inboard and outboard bellows assemblies (34A) and (34)
- Inboard and outboard mating rings (3B) and (3C)
- All O-rings (P, P1, 6, 6A, G1, 11, 11A)
- Gland gasket (G)
- Vibration dampeners (M) and (M1)
- Retaining ring (RR)
- Centering tabs (CT) and cap screws (K)
- Cup point and quarter dog set screws (13) and (13A)

Reconditionable Seal Parts

- Gland assembly (1)
- Sleeve assembly (SL)
- Inner gland (1B)
- Rotor carrier (14)
- Sleeve collar (9)

3 Inspection and Reconditioning

3.1 There are certain critical areas of each part where special attention should be paid to the condition. If any of the areas listed in 3.2, 3.3 or 3.4 show signs of wear, corrosion, or other defects that cannot be removed without affecting the dimensional size of the surfaces by more than 0.001 to 0.002", then the respective part should be replaced. If grit blasting is performed, it may be necessary to polish the O-ring surfaces to achieve the required surface finish (see 3.2A and 3.3A for the required surface finish). If any parts require machining to correct damage, please contact your Flowserve representative for dimensional requirements, or for any other questions regarding repair.

3.2 Gland Assembly (1) (Figure 2)

- A Mating ring O-ring surface** - Inspect for wear, fretting, nicks, scratches, or corrosion.
Required surface finish: 63 RMS
- B Gasket surface** - Remove the old gasket and clean the gasket surface. Inspect for nicks, scratches, or corrosion.
- C Pipe taps and other threaded holes** - Inspect for damaged threads or corrosion. Taps must be clean and free of debris and corrosion. Re-tap as necessary.
- D Bushing** - Inspect for wear, breakage, or loosened bond with gland. Replace using Loctite® 7471 Primer T and Loctite RC™/640 or equivalent to adhere the bushing if any of these conditions exist. A ten minute cure at 400°F (204°C) is required to achieve full bond strength. If worn or corroded, contact your Flowserve representative.
- E Gland drive ring (1B)** - Inspect for wear or corrosion. If worn or corroded, contact your Flowserve representative.

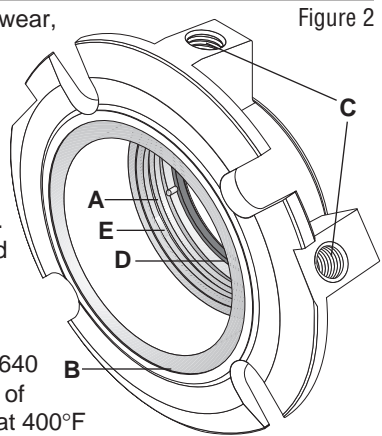

3.3 Sleeve Assembly (SL) (Figure 3)

- A O-ring surfaces** - Inspect for wear, nicks, scratches, or corrosion. *Required surface finish: 63 RMS.*
- B Drive Ring (10A)** - Inspect for wear or corrosion, especially at drive flat surfaces on ID of drive ring.
- C Drive flats** for rotor carrier - Inspect for wear, rounding of edges of flats, or corrosion.
- D Drive end roundness**
No greater than 0.001" TIR

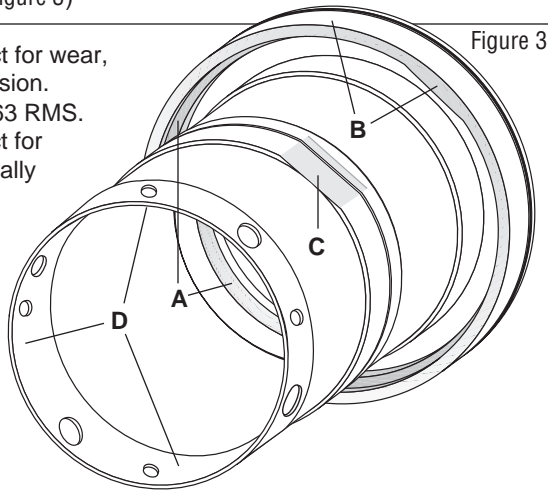

Figure 3

3.4 Inner Gland (1C) (Figure 4)

- A Mating ring O-ring surface** - Inspect for wear, fretting, nicks, scratches, or corrosion. *Required surface finish: 63 RMS*
- B Gland O-ring surface** - Inspect for wear, nicks, scratches, or corrosion. *Required surface finish: 63 RMS.*
- C Gasket surface** - Remove old gasket and clean surface. Inspect for nicks, scratches, or corrosion.
- D Drive flats** - Inspect for wear or corrosion. If worn or corroded, contact your Flowserve representative.

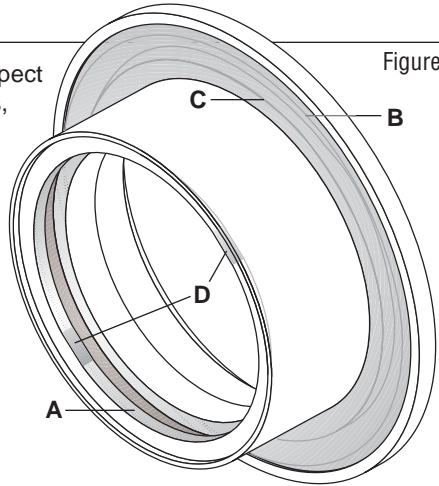

Figure 4

3.5 Rotor Carrier (14) (Figure 5)

- A O-ring surfaces** - Inspect for wear, nicks, scratches, or corrosion. *Required surface finish: 63 RMS.*
- B Pumping vanes** - Inspect for wear, damage, or corrosion.
- C Drive flats** - Inspect for wear or corrosion.

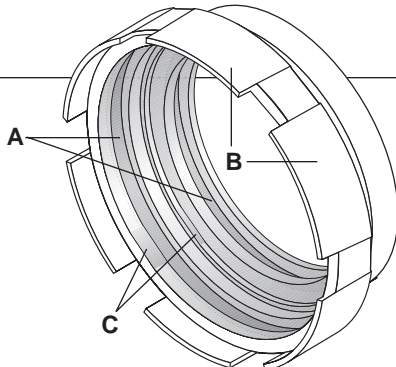

Figure 5

3.6 Sleeve Collar ⑨ (Figure 6)

- A Threaded holes** - Inspect for thread damage and re-tap as necessary.
- B ID bore roundness** - *No greater than 0.002" TIR*
- C Set screws** - Replace cup point and dog point set screws with those included with the repair kit.
Make sure the same threaded holes are used with the same type set screws.

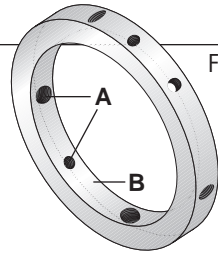

Figure 6

4 Seal Assembly Instructions

4.1 Tools Required

- 3/32", 1/8" hex key wrenches (Sizes < 2.625"); 1/8", 3/16" hex key wrenches (Sizes 2.625" and larger)
- Silicone grease (included in repair kit)
- Ethyl alcohol or acetone and clean, lint free towel for cleaning seal faces

4.2 As part of the assembly of the seal, there are several blind fits of pins and drive flats. It may be helpful to mark the locations of the pins or drive flats with a felt tip marker, or to align the feature with another visible feature on the seal to assist with assembly. All seal faces should be cleaned with alcohol or acetone prior to placing the faces together at each respective step in the assembly process.

4.3 Arrange O-rings by diametrical size. There are four sizes total: quantity 1 of the largest size O-ring ⑥①, quantity four of the 2nd largest size O-ring ③ ③① ⑥ and ⑥①, quantity one of the 2nd smallest size O-ring ①①① and quantity 1 of the smallest size O-ring ①①. Prior to installing each O-ring at its respective step, lightly lubricate with silicone grease and stretch slightly.

4.4 Place the sleeve assembly ⑨ on a flat surface with the collar end facing up. Install the inboard vibration dampener ①① into the sleeve end housing. Place the inboard bellows O-ring ⑥① in the sleeve O-ring groove behind the surface with drive flats in the sleeve. (Figure 7)

Figure 7



Figure 8

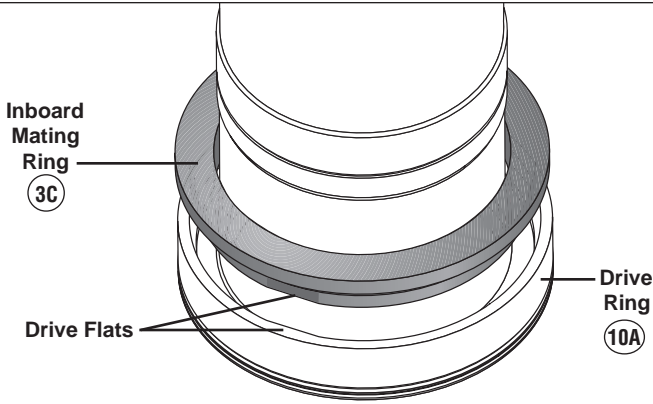

4.5 Align the two flats on the inboard mating ring (3C) with the two flats on the inside of the drive ring (10A) in the sleeve end housing, and press the mating ring into place using finger pressure only. (Figure 8)

4.6 Place the inboard bellows O-ring (P1) into the inner gland (1C). (Figure 9)

Figure 9

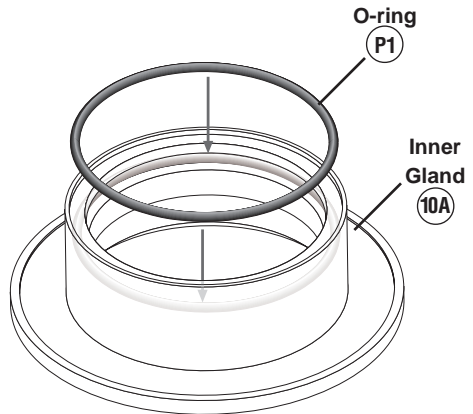

4.7 Align the two flats on the inboard bellows assembly (34A) with the two flats on the inside of the inner gland, and press the bellows in place using finger pressure only. **Be careful not to over compress the bellows assembly.** (Figure 10)

Figure 10

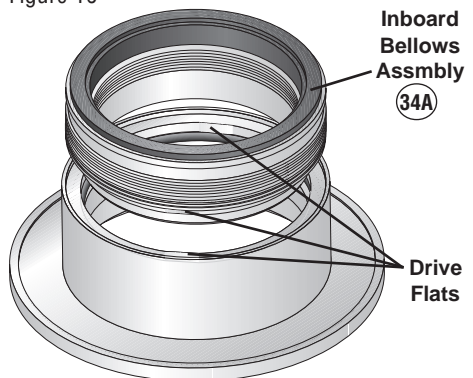

4.8 Place the inner gland/bellows assembly face down onto the sleeve/mating ring assembly. (Figure 11)

4.9 Install the inner gland O-ring (G1) into the face groove in the inner gland. (Figure 11)

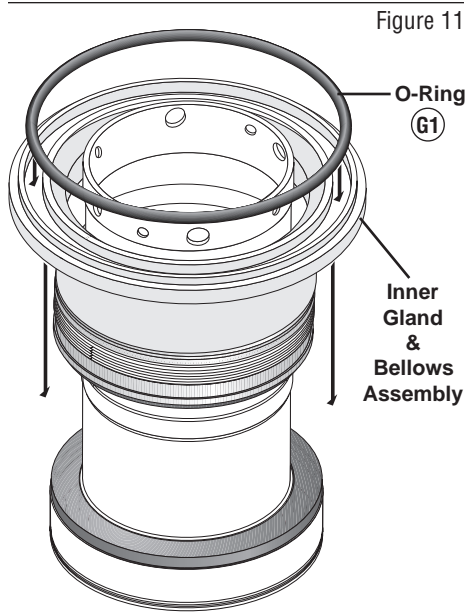

Figure 11

4.10 Place the rotor carrier O-ring (11A) in the smallest diameter groove of the rotor carrier (14). (Figure 12)

4.11 Align the three drive flats on the rotor carrier with the drive flats on the sleeve and press the rotor carrier on the sleeve with the pumping vanes facing up. (Figure 13)



Figure 12

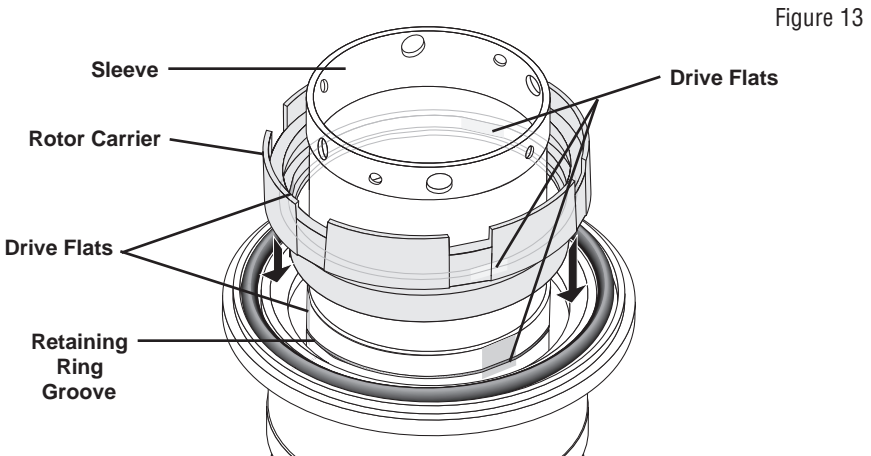
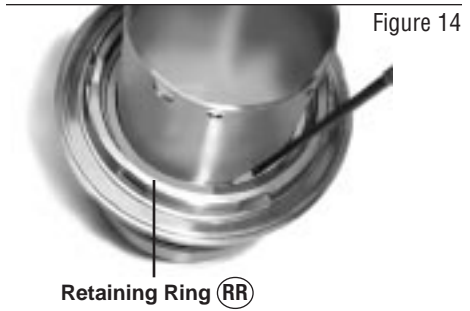
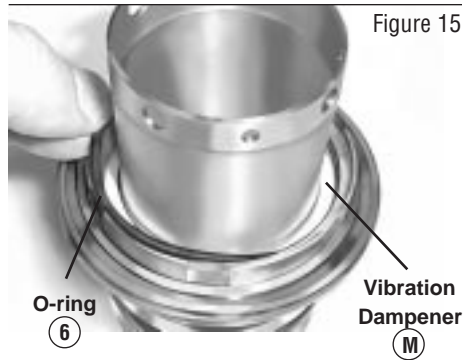

Figure 13

4.12 Insert the retaining ring (RR) into the groove in the sleeve assembly while pressing down on the rotor carrier. Make sure that the retaining ring snaps completely into the groove in the sleeve assembly. (Figure 14)



4.13 Insert the outboard vibration dampener (M) into the rotor carrier. Make sure that the vibration dampener is fully seated at the bottom of the rotor carrier. Place the outboard mating ring O-ring (6) in the O-ring groove of the rotor carrier, which is behind the surface with two drive flats. (Figure 15)



4.14 Assemble the outboard mating ring (3B) into the sleeve/rotor carrier assembly, aligning the drive flats on the carrier and mating ring. (Figure 16)

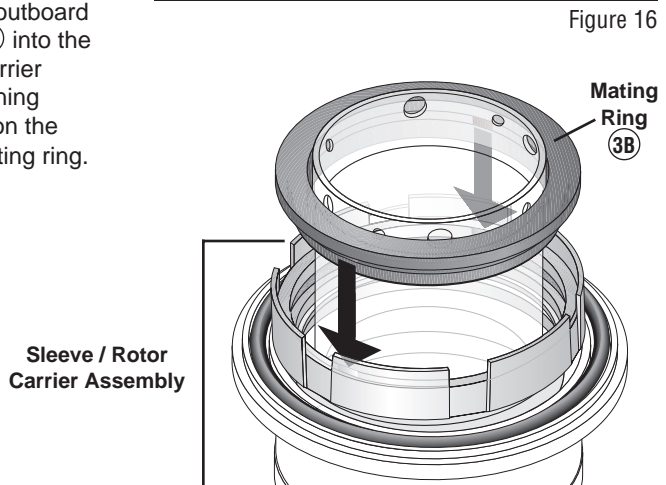

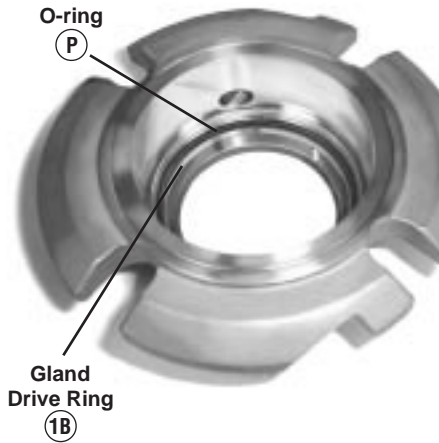

4.15 Assemble the outboard bellows O-ring (P) into the gland assembly. (Figure 17)

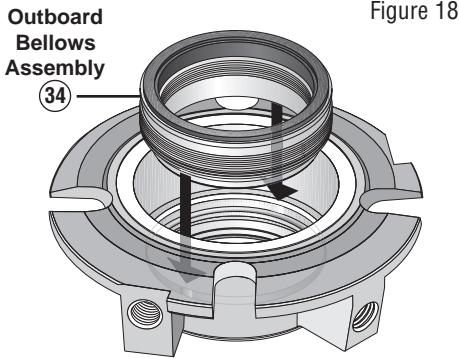

4.16 Assemble the outboard bellows assembly (34) into the gland assembly, aligning the drive flats on the gland assembly and bellows assembly. (Figure 18)

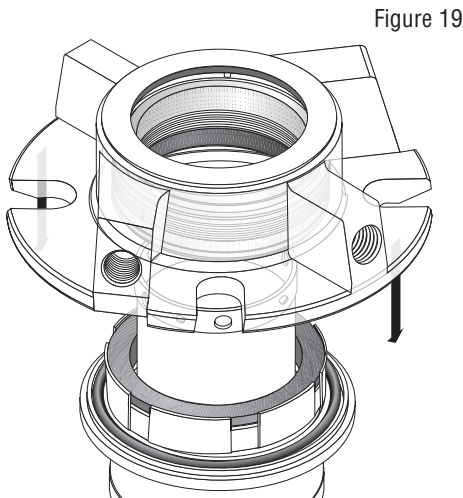

4.15 Place the gland/bellows assembly face down onto the sleeve/outboard mating ring assembly. (Figure 19)

4.16 Place the sleeve collar ⑨ onto the end of the sleeve with the Flowserve logo facing up. Align the quarter dog set screws with the smaller holes in the end of the sleeve. On smaller seal sizes, one of the quarter dog set screws will be offset by 15 degrees. Align this quarter dog set screw with the corresponding offset hole in the end of the sleeve. Do not tighten any set screws at this time. Install the centering tabs (CT) and flat head cap screws into the collar while engaging with the gland. Be sure to keep the collar aligned. (Figure 20)

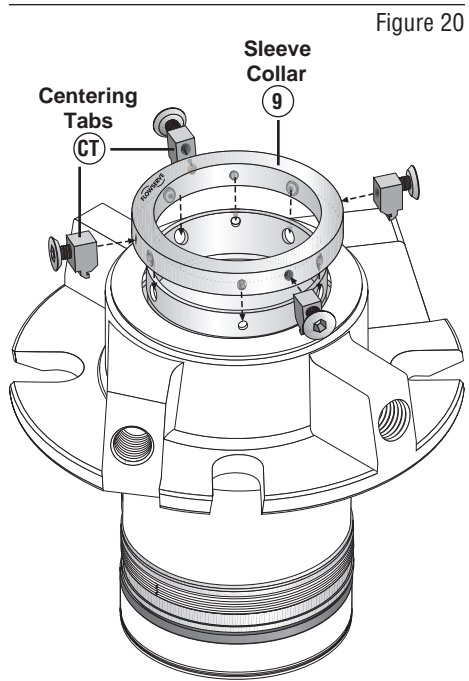

4.17 Using firm hand pressure press down on the collar to be even with the end of the sleeve assembly. This will in turn press down the gland and inner gland, compressing the bellows. While holding the collar even with the end of the sleeve assembly, tighten the quarter dog set screws into the holes in the sleeve until snug. Be careful not to distort the sleeve by over tightening the quarter dog set screws. (Figure 21)



Figure 22

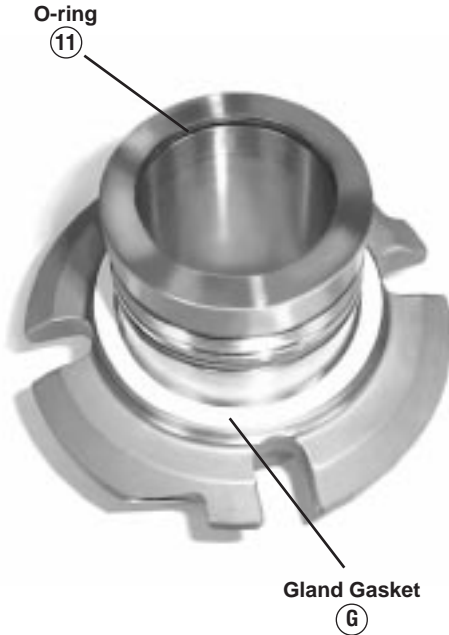

4.18 Install the shaft O-ring (11) into the inside diameter groove of the sleeve assembly. (Figure 22)

4.19 Adhere the gland gasket (G) to the inner gland gasket surface with a spray adhesive such as 3M Super 77^{®2}.

5 Static Testing

5.1 Flowserve manufacturing typically tests the ISC at 25 psig. A pressure drop of less than one psi over a one minute time period at 25 psig using a test set-up with a maximum fluid volume of one cubic foot is acceptable. To static test the seal, bolt or clamp the seal to a pump seal chamber or other device which will hold the inner gland up against the gland. Failure to do this will result in the inner gland unseating from the gland under pressure, possibly resulting in damage to the inner gland O-ring and also causing a personal safety risk. Secure the cup point set screws to the stub shaft or equipment shaft to help prevent deformation of the centering tabs due to axial loads. Apply pressure at either of the tangential barrier fluid ports, while plugging the opposite port. If the seal does not pass the static pressure test, disassemble the seal and inspect for O-ring damage, as this is the most common cause of static test failure.

6 Installation

6.1 Refer to the ISC Installation Instructions, FIS120, for proper seal installation.

TO REORDER REFER TO
B/M # _____
F.O. _____

The information and specifications presented in these repair instructions are believed to be accurate, but are not guaranteed by Flowserve as to completeness or accuracy. Although Flowserve Corporation can provide general application guidelines, it cannot provide specific information for all possible applications. The purchaser/user must therefore assume the ultimate responsibility for the proper selection, installation, operation and maintenance of Flowserve products. Because Flowserve Corporation is continually improving and upgrading its product design, the specifications, dimensions and information contained herein are subject to change without notice.

Flowserve Corporation

Flow Solutions Division

Primary Worldwide Flow Solutions Division Locations

Licenseses, authorized agents, and affiliated companies located worldwide

United States	Canada	Netherlands	Argentina	Australia	
Kalamazoo, MI Phone 616-381-2650 Fax 616-381-8368	Edmonton, Alberta Phone 780-463-7958 Fax 780-450-1241	Scarborough, Ontario Phone 416-292-2877 Fax 416-292-5190	Roosendaal Phone 31-165-581400 Fax 31-165-552622	Villa Martelli Phone 54-11-4709-6800 Fax 54-11-4709-7072	Marayong NSW Phone 61-2-8822-7100 Fax 61-2-9679-7511
Singapore	Mexico	Brazil	Japan	Germany	
Phone 65-746-4318 Fax 65-747-1963	Tlaxcala Phone 52-2-461-6791 Fax 52-2-461-6847	Sao Paulo Phone 55-11-4066-8600 Fax 55-11-4066-70144	Osaka Phone 81-720-85-5571 Fax 81-720-85-5575	Dortmund Phone 49-231-6964-0 Fax 49-231-6964-248	

www.flowserve.com

Printed in U.S.A.

ISO 9000
Certified

FIS141
ORG 06/00 USA