

1-1/4" – 2" 3-Piece Ball Valves  
Including Series 4, 44, CL44, H44, PT44, CN44, W44, MP44, FZ44

1" - 2" Series 59 Full Port Ball Valves  
Including Series W59, PT59

**1-1/4" & 1-1/2"**  
**Series 59**

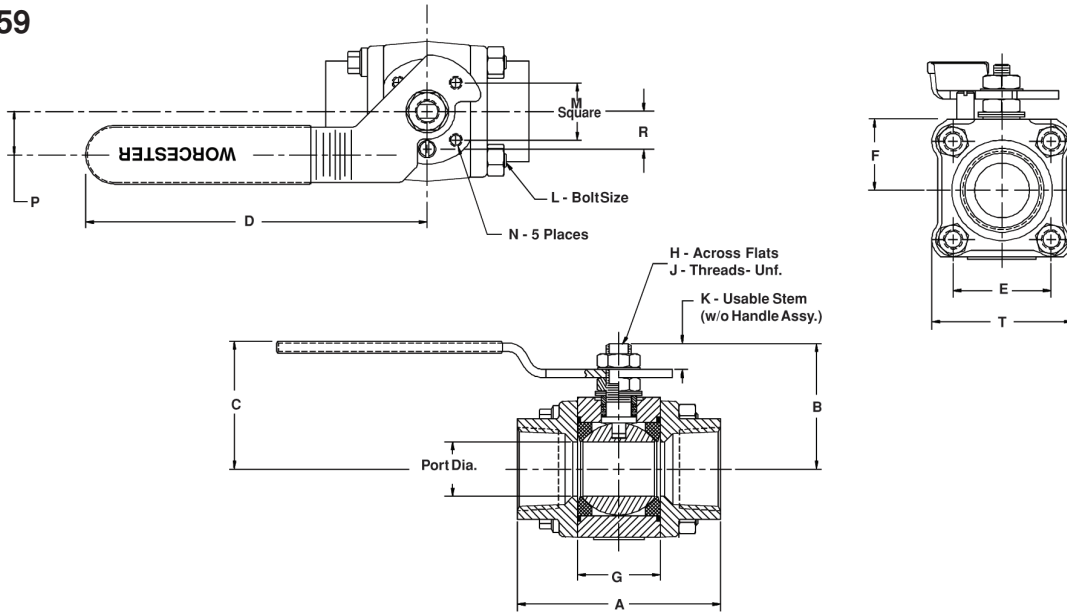

**2"**  
**Series 59**

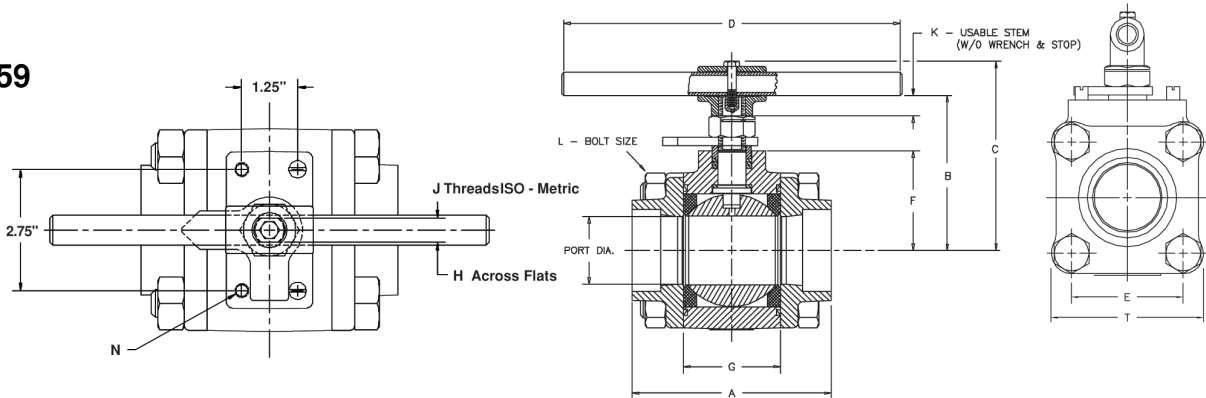

Valve Size	A	B	C	D	E	F	G	H	J	K	L	M	N	P	R	T
44 Series 59																
1-1/4" 1"	4.16 (105.7)	2.38 (60.5)	2.47 (62.7)	6.53 (165.9)	2.00 (50.8)	1.46 (37.1)	1.63 (41.3)	.296 (7.2)	7/16"-20	.430 (10.9)	3/8"-16	1.17 (29.7)	1/4"-20	.830 (21.1)	.768 (19.5)	2.70 (68.6)
1-1/2" 1-1/4"	4.50 (114.3)	2.88 (73.2)	2.83 (71.9)	8.03 (204.0)	2.25 (57.2)	1.73 (43.9)	1.91 (48.4)	.343 (8.7)	9/16"-18	.610 (15.5)	7/16"-14	1.39 (35.3)	1/4"-20	.990 (25.2)	.906 (23.0)	3.16 (80.3)
2" 1-1/2"	4.94 (125.5)	3.06 (77.7)	3.02 (76.7)	8.03 (204.0)	2.62 (66.6)	1.92 (48.8)	2.22 (56.3)	.343 (8.7)	9/16"-18	.600 (15.2)	1/2"-13	1.39 (35.3)	1/4"-20	.990 (25.2)	.906 (23.0)	3.56 (90.4)
— 2"	5.86 (148.8)	4.56 (115.8)	5.69 (144.5)	10.00 (254.0)	3.35 (85.1)	2.92 (74.2)	2.86 (72.6)	.550 (14.0)	M20x2.5	.660 (16.8)	5/8"-11	—	M8x1.25	—	—	4.57 (116.1)

Dimensions are for layout only. For tolerances, contact Worcester Controls. Metric dimensions are converted from standard English.

# PIPE ENDS

1-1/4" – 2" 3-Piece Ball Valves  
Including Series 4, 44, CL44, H44, PT44, W44, CN44, MP44, FZ44

1" - 2" Series 59 Full Port Ball Valves  
Including Series W59, PT59

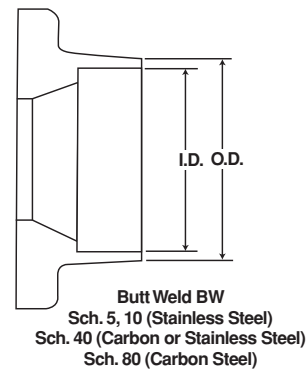
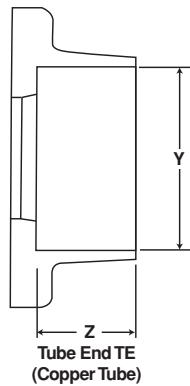
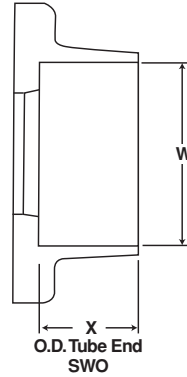
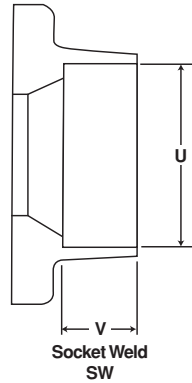

Valve Size	Socket Weld		O.D. Tube End SWO		Tube End TE		ButtWeld				ButtWeld				Port	Approx. Weight	
	Series 44	Series 59	U	V	W	X	Y	Z	Sch. 5		Sch. 10		Sch. 40				Sch. 80
								O.D.	I.D.	O.D.	I.D.	O.D.	I.D.	O.D.	I.D.		Lbs. (Kg.)
1-1/4"	1"	1.68 (42.5)	.720 (18.3)	1.26 (32.0)	.620 (15.8)	1.38 (35.0)	1.03 (26.2)	1.66 (42.2)	1.53 (38.9)	1.66 (42.2)	1.44 (36.5)	1.66 (42.2)	1.38 (35.1)	1.66 (42.2)	1.27 (32.3)	1.00 (25.4)	4.50 (2.04)
1-1/2"	1-1/4"	1.92 (48.6)	.720 (18.3)	1.51 (38.4)	.620 (15.8)	1.63 (41.4)	1.15 (29.2)	1.91 (48.5)	1.77 (45.0)	1.91 (48.5)	1.67 (42.5)	1.91 (48.5)	1.59 (40.5)	1.91 (48.5)	1.52 (38.6)	1.25 (31.8)	6.20 (2.82)
2"	1-1/2"	2.41 (61.1)	.840 (21.3)	2.01 (51.1)	.670 (17.0)	2.13 (54.1)	1.15 (29.2)	2.38 (60.5)	2.24 (57.0)	2.38 (60.5)	2.15 (54.5)	2.38 (60.0)	2.06 (52.4)	2.38 (60.5)	1.93 (48.9)	1.50 (38.1)	9.50 (4.31)
—	2"	2.41 (61.1)	.84 (21.3)	—	—	—	—	2.38 (60.5)	2.24 (57.0)	2.38 (60.5)	2.15 (54.5)	2.38 (60.0)	2.06 (52.4)	2.38 (60.5)	1.93 (48.9)	2.00 (50.8)	20.00 (9.08)

Dimensions are for layout only. For tolerances, contact Worcester Controls. Metric dimensions are converted from standard English.