



USER INSTRUCTIONS

Casing Blind Covers Metallic Pumps

ASME (ANSI) Pumps

PCN= 75663450 – 04-10 (E)
Original Instructions

Installation Operation Maintenance

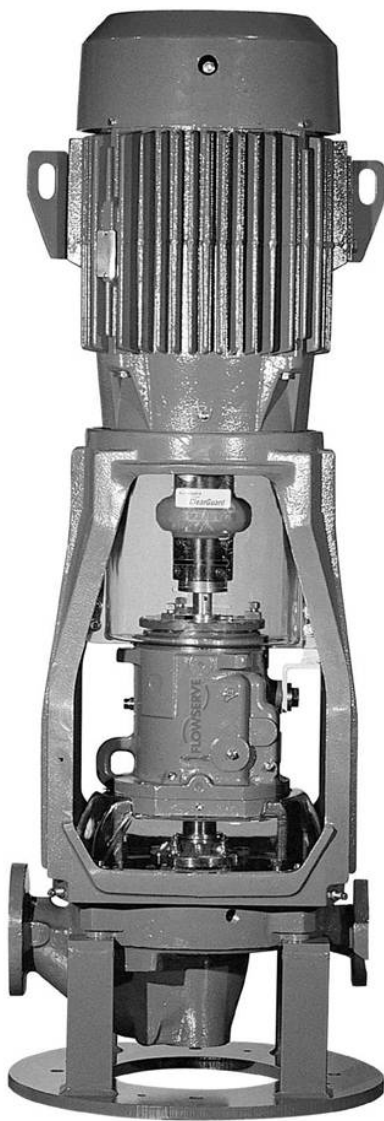

CONTENTS

	Page
1 INTRODUCTION AND SAFETY	3
1.1 General	3
1.2 CE marking and approvals.....	3
1.3 Disclaimer	3
1.4 Copyright.....	3
1.5 Duty conditions	3
1.6 Safety	4
1.7 Specific machine performance.....	5
2 TRANSPORT AND STORAGE	5
2.1 Consignment receipt and unpacking	5
2.2 Handling.....	5
2.3 Lifting.....	6
2.4 Storage.....	6
2.5 Recycling and end of product life.....	6
3 DESCRIPTION	6
3.1 Configurations.....	6
3.2 Nameplate.....	6
3.3 Performance and operation limits	7
4 MAINTENANCE.....	10
4.1 Maintenance schedule	10
4.2 Tools required.....	10
4.3 Examination of parts	10
5 INSTALLATION	11
5.1 Pump Power End Removal.....	11
5.2 Casing Blind Cover Installation	11
6 REMOVAL	11
7 PARTS LIST AND DRAWINGS.....	12
8 CERTIFICATION	13
9 OTHER RELEVANT DOCUMENTATION AND MANUALS	13
9.1 Supplementary User Instructions.....	13
9.2 Change notes.....	13
9.3 Additional sources of information.....	13

1 INTRODUCTION AND SAFETY

1.1 General



These instructions must always be kept close to the product's operating location or directly with the product.

Flowserve products are designed, developed and manufactured with state-of-the-art technologies in modern facilities. The unit is produced with great care and commitment to continuous quality control, utilizing sophisticated quality techniques, and safety requirements.

Flowserve is committed to continuous quality improvement and being at your service for any further information about the product in its installation and operation or about its support products, repair and diagnostic services.

These instructions are intended to facilitate familiarization with the product and its permitted use. Operating the product in compliance with these instructions is important to help ensure reliability in service and avoid risks. The instructions may not take into account local regulations; ensure such regulations are observed by all, including those installing the product. Always coordinate repair activity with operations personnel, and follow all plant safety requirements and applicable safety and health laws/regulations.

These instructions provide information relative to the Casing Blind Covers only. These instructions must be used in conjunction with the manuals provided with the pump.



These instructions must be read prior to installing, operating, using and maintaining the equipment in any region worldwide. These supplemental instructions must be used in conjunction with the pump user instruction manual. The equipment must not be put into service until all the conditions relating to safety noted in the instructions, have been met.

1.2 CE marking and approvals

It is a legal requirement that machinery and equipment put into service within certain regions of the world shall conform with the applicable CE Marking Directives covering Machinery and, where applicable, Low Voltage Equipment, Electromagnetic Compatibility (EMC), Pressure Equipment Directive (PED) and Equipment for Potentially Explosive Atmospheres (ATEX).

Where applicable, the Directives and any additional Approvals, cover important safety aspects relating to machinery and equipment and the satisfactory provision of technical documents and safety instructions. Where applicable this document incorporates information relevant to these Directives and Approvals.

To confirm the Approvals applying and if the product is CE marked, check the serial number plate markings and the Certification. (See section 7, *Certification*.)

1.3 Disclaimer

Information in these User Instructions is believed to be reliable. In spite of all the efforts of Flowserve to provide sound and all necessary information the content of this manual may appear insufficient and is not guaranteed by Flowserve as to its completeness or accuracy.

Flowserve manufactures products to exacting International Quality Management System Standards as certified and audited by external Quality Assurance organizations. Genuine parts and accessories have been designed, tested and incorporated into the products to help ensure their continued product quality and performance in use. As Flowserve cannot test parts and accessories sourced from other vendors the incorrect incorporation of such parts and accessories may adversely affect the performance and safety features of the products. The failure to properly select, install or use authorized Flowserve parts and accessories is considered to be misuse. Damage or failure caused by misuse is not covered by the Flowserve warranty. In addition, any modification of Flowserve products or removal of original components may impair the safety of these products in their use.

1.4 Copyright

All rights reserved. No part of these instructions may be reproduced, stored in a retrieval system or transmitted in any form or by any means without prior permission of Flowserve.

1.5 Duty conditions

This product has been selected to meet the specifications of your purchaser order. The acknowledgement of these conditions has been sent separately to the Purchaser. A copy should be kept with these instructions.

 **The product must not be operated beyond the parameters specified for the application. If there is any doubt as to the suitability of the product for the application intended, contact Flowserve for advice.**

 **The blind cover has been provided with a standard gasket material which may not be appropriate for your service. Please ensure material compatibility before installation.**

 **Cover plate material compatibility is the responsibility of the end user.**

If the conditions of service on your purchase order are going to be changed (for example liquid pumped, temperature or duty) it is requested that the user seeks the written agreement of Flowserve before start up.

1.6 Safety

1.6.1 Summary of safety markings

These User Instructions contain specific safety markings where non-observance of an instruction would cause hazards. The specific safety markings are:

 **DANGER** This symbol indicates electrical safety instructions where non-compliance will involve a high risk to personal safety or the loss of life.

 This symbol indicates safety instructions where non-compliance would affect personal safety and could result in loss of life.

 This symbol indicates “hazardous and toxic fluid” safety instructions where non-compliance would affect personal safety and could result in loss of life.

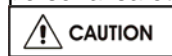
 This symbol indicates safety instructions where non-compliance will involve some risk to safe operation and personal safety and would damage the equipment or property.

 This symbol indicates explosive atmosphere zone marking according to ATEX. It is used in safety instructions where non-compliance in the hazardous area would cause the risk of an explosion.

 This symbol is used in safety instructions to remind not to rub non-metallic surfaces with a dry cloth; ensure the cloth is damp. It is used in safety instructions where non-compliance in the hazardous area would cause the risk of an explosion.

Note: This sign is not a safety symbol but indicates an important instruction in the assembly process.

1.6.2 Personnel qualification and training

All personnel involved in the operation, installation, inspection and maintenance of the unit must be qualified to carry out the work involved. If the personnel in question do not already possess the necessary knowledge and skill, appropriate training and instruction must be provided. If required the operator may commission the manufacturer/supplier to provide applicable training.

Always coordinate repair activity with operations and health and safety personnel, and follow all plant safety requirements and applicable safety and health laws and regulations.

1.6.3 Safety action

This is a summary of conditions and actions to help prevent injury to personnel and damage to the environment and to equipment. For products used in potentially explosive atmospheres section 1.6.4 also applies.

 **DANGER** NEVER DO MAINTENANCE WORK WHEN THE UNIT IS CONNECTED TO POWER (Lock out.)

 **DRAIN THE PUMP AND ISOLATE PIPEWORK BEFORE DISMANTLING THE PUMP**
The appropriate safety precautions should be taken where the pumped liquids are hazardous.

 **FLUOROELASTOMERS (When fitted.)**
When a pump has experienced temperatures over 250 °C (482 °F), partial decomposition of fluoroelastomers (example: Viton) will occur. In this condition these are extremely dangerous and skin contact must be avoided.

 **HANDLING COMPONENTS**
Many precision parts have sharp corners and the wearing of appropriate safety gloves and equipment is required when handling these components. To lift heavy pieces above 25 kg (55 lb) use a crane appropriate for the mass and in accordance with current local regulations.

 **NEVER OPERATE THE PUMP WITHOUT THE COUPLING GUARD AND ALL OTHER SAFETY DEVICES CORRECTLY INSTALLED**

 **GUARDS MUST NOT BE REMOVED WHILE THE PUMP IS OPERATIONAL**



THERMAL SHOCK

Rapid changes in the temperature of the liquid within the pump can cause thermal shock, which can result in damage or breakage of components and should be avoided.



HOT (and cold) PARTS

If hot or freezing components or auxiliary heating equipment can present a danger to operators and persons entering the immediate area, action must be taken to avoid accidental contact (such as shielding). If complete protection is not possible, the machine access must be limited to maintenance staff only with clear visual warnings and indicators to those entering the immediate area. Note: bearing housings must not be insulated and drive motors and bearings may be hot.

If the temperature is greater than 80 °C (176°F) or below -5 °C (23 °F) in a restricted zone, or exceeds local regulations, action as above shall be taken.



HAZARDOUS LIQUIDS

When the pump is handling hazardous liquids care must be taken to avoid exposure to the liquid by appropriate pump placement, limiting personnel access and by operator training. If the liquid is flammable and/or explosive, strict safety procedures must be applied.



PREVENT EXCESSIVE EXTERNAL PIPE LOAD

Do not use pump as a support for piping. Do not mount expansion joints, unless allowed by Flowserve in writing, so that their force, due to internal pressure, acts on the pump flange.



NEVER EXCEED THE MAXIMUM DESIGN PRESSURE (MDP) AT THE TEMPERATURE SHOWN ON THE PUMP NAMEPLATE

See section 3 for pressure versus temperature ratings based on the material of construction.

1.6.4 Products used in potentially explosive atmospheres



Measures are required to:

- Avoid excess temperature
- Prevent build up of explosive mixtures
- Prevent the generation of sparks
- Prevent leakages
- Maintain the pump to avoid hazard



Refer to the instruction manual provided with the pump for more information.

1.6.4.1 Maintenance of the centrifugal pump to avoid a hazard



CORRECT MAINTENANCE IS REQUIRED TO AVOID POTENTIAL HAZARDS WHICH GIVE A RISK OF EXPLOSION

The responsibility for compliance with maintenance instructions is with the plant operator.

To avoid potential explosion hazards during maintenance, the tools, cleaning and painting materials used must not give rise to sparking or adversely affect the ambient conditions. Where there is a risk from such tools or materials, maintenance must be conducted in a safe area.

It is recommended that a maintenance plan and schedule is adopted. (See section 6, *Maintenance*.)

1.7 Specific machine performance

For performance parameters see section 1.5, Duty conditions. Where performance data has been supplied separately to the purchaser these should be obtained and retained with these User Instructions if required.

2 TRANSPORT AND STORAGE

2.1 Consignment receipt and unpacking

Immediately after receipt of the equipment it must be checked against the delivery/shipping documents for its completeness and that there has been no damage in transportation. Any shortage and/or damage must be reported immediately to Flowserve Pump Division and must be received within ten days of receipt of the equipment. Later claims cannot be accepted.

Check any crate, boxes or wrappings for any accessories or spare parts that may be packed separately with the equipment or attached to side walls of the box or equipment.

2.2 Handling

Boxes, crates, pallets or cartons may be unloaded using fork lift vehicles or slings dependent on their size and construction.

2.3 Lifting



Pumps and motors often have integral lifting lugs or eye bolts. These are intended for use in only lifting the individual piece of equipment.



Do not use eye bolts or cast-in lifting lugs to lift pump, motor and baseplate assemblies.



Care must be taken to lift components or assemblies above the center of gravity to prevent the unit from flipping. This is especially true with In-Line pumps.

2.3.1 Lifting pump components

Casing Blind Cover [1220]

Insert an eye bolt in the tapped hole as provided. Use either a sling or hook through the eye bolt.

2.4 Storage



Store the pump in a clean, dry location away from vibration. Leave flange covers in place to keep dirt and other foreign material out of pump casing. The pump may be stored as above for up to 6 months. Consult Flowserve for preservative actions when a longer storage period is needed.

2.4.1 Short term storage and packaging

Normal packaging is designed to protect the pump and parts during shipment and for dry, indoor storage for up to six months or less. The following is an overview of our normal packaging:

All loose unmounted items are packaged in a water proof plastic bag and placed under the coupling guard

The internal surfaces of ferrous casings, covers, flange faces, and the impeller surface are sprayed with Cortec VCI-389, or equal

The pump must be stored in a covered, dry location

2.4.2 Long term storage and packaging

Long term storage is defined as more than six months, but less than 12 months. The procedure Flowserve follows for long term storage of pumps is given below. These procedures are in addition to the short term procedure.

Each assembly is hermetically (heat) sealed from the atmosphere by means of tack wrap sheeting and rubber bushings (mounting holes)

Desiccant bags are placed inside the tack wrapped packaging

This packaging will provide protection for up to twelve months from humidity, salt laden air, dust etc.

2.5 Recycling and end of product life

At the end of the service life of the product or its parts, the relevant materials and parts should be recycled or disposed of using an environmentally acceptable method and in accordance with local regulations. If the product contains substances that are harmful to the environment, these should be removed and disposed of in accordance with current local regulations. This also includes the liquids and/or gases that may be used in the "seal system" or other utilities.



Make sure that hazardous substances are disposed of safely and that the correct personal protective equipment is used. The safety specifications must be in accordance with the current local regulations at all times.

3 DESCRIPTION

3.1 Configurations

The Casing Blind Covers are designed to replace the back pull out unit and prevent product leakage during maintenance.

3.2 Nameplate

Figure 3-1: Nameplate mounted to blind cover

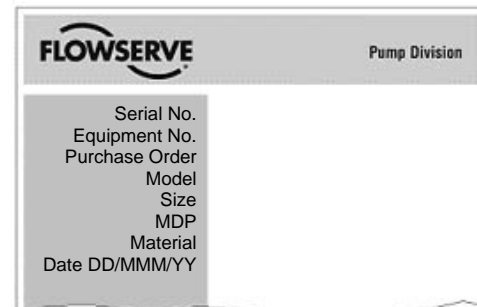

The casing blind cover nameplate, at a minimum will contain the following information:

Model – Description of pump model and size

MDP - Maximum design pressure at 38°C(100°F)

Material – Flowserve Material Code. See section 3.2

3.3 Performance and operation limits

This product has been selected to meet the specification of your purchase order. See section 1.5.

The following data is included as additional information to help with your installation. It is typical, and factors such as liquid being pumped, temperature, material of construction, and seal type may influence this data. If required, a definitive statement for your application can be obtained from Flowserve.

CAUTION The following provides pressure-temperature ratings for the blind covers only. The lowest rating of all parts connected to the casing must be used. Consult the user instructions provided with the pump.

CAUTION Cover plate material compatibility is the responsibility of the end user.

3.3.1 Alloy cross reference chart

Figure 3-2 is the Alloy cross-reference chart for Flowserve ASME (ANSI) pumps.

Figure 3-3 is the Alloy cross reference chart for wrought casing blind covers.

3.3.2 Pressure-temperature ratings

The pressure–temperature (P-T) ratings for blind covers are shown in figure 3-4. Determine the appropriate cover “Material Group No.” in Figure 3-2. Interpolation may be used to find the pressure rating for a specific temperature.

Example:

The pressure temperature rating for a Mark 3 GP2 blind cover, 316 construction, with an operating temperature of 149°C is found as follows:

- a) From Figure 3-2, the correct material group is 2.2
- b) From Figure 3-4C, the pressure-temperature rating is 21.5 bar.

Figure 3-2: Casing Blind Cover Alloy cross-reference chart

Flowserve Material Code	Generic Designation	Specifications	Material Group No.
D3041	316 Plate	A240 Type 316 (UNS Designation S31600)	2.2
D3134	Steel Plate	A515 Gr. 70 (Gr. 485 - S.I. units)	1.1

Figure 3-3: Casing Cast Alloy cross-reference chart

Flowserve Material Code	Generic Designation	Durco Legacy Codes	ASTM Specifications	Material Group No.
E3020	Ductile iron	DCI	A395, Gr. 60-40-18	1.0
E3033	High chrome iron	CR28	A532 class 3	Cr
E4027	High chrome iron	CR29	None	Cr
E4028	High chrome iron	CR35	None	Cr
C3009	Carbon steel	DS	A216 Gr. WCB	1.1
C3062	304	D2	A744, Gr. CF8	2.1
C3069	304L	D2L	A744, Gr. CF3	2.1
C3063	316	D4	A744, Gr. CF8M	2.2
C3067	316L	D4L	A744, Gr. CF3M	2.2
C3107	Duplex Stainless	CD4M	A995, Gr. CD4MCuN	2.8
C4028	Alloy 20	D20	A744, Gr. CN7M	3.17
C4029	Durcomet 5	DV	None	2.2
K3005	Inconel 600	DINC	A494, Gr. CY40	3.5
K3007	Monel 400	DMM	A494, Gr. M35-1	3.4
K3008	Nickel	DNI	A494, Gr. CZ100	3.2
K4007	Hastelloy B	DC2	A494, Gr. N7M	3.7
K4008	Hastelloy C	DC3	A494, Gr. CW6M	3.8
E3041	Duriron	D	A518, Gr. 1	No load
E3042	Durichlor 51	D51	A518, Gr. 2	No load
E4035	Superchlor	SD51	A518, Gr. 2	No load
D4036	Durco DC8	DC8	None	-
H3004	Titanium	Ti	B367, Gr. C3	Ti
H3005	Titanium-Pd	TiP	B367, Gr. C8A	Ti
H3007	Zirconium	Zr	B752, Gr. 702C	Ti

Duriron, Durichlor 51 and Superchlor are registered trademarks of Flowserve Corporation.

Hastelloy is a registered trademark of Haynes International, Inc.

Inconel and Monel are registered trademarks of International Nickel Co. Inc.



Figure 3-4A Blind Cover Ratings
Durco Mark 3 GP3 Pumps, Durco Mark 2, Durco Mark 2 In-Line, Durco Mark 3 In-Line
Worthington D1000 Pumps

Temp °C	Material Group No.										
	1.1	2.1	2.2	2.8	3.2	3.4	3.5	3.7	3.8	3.17	Ti
	bar										
-73		24.1	24.1	24.1	17.4	24.1	24.1	24.1	24.1	24.1	24.1
-29	24.1	24.1	24.1	24.1	17.4	24.1	24.1	24.1	24.1	24.1	24.1
-18	24.1	24.1	24.1	24.1	17.4	24.1	24.1	24.1	24.1	24.1	24.1
38	24.1	24.1	24.1	24.1	17.4	24.1	24.1	24.1	24.1	24.1	24.1
93	22.0	20.1	20.8	23.2	17.4	21.3	22.9	24.1	24.1	20.9	21.4
149	21.4	18.1	18.8	21.4	17.4	19.9	21.4	23.5	23.5	18.7	18.7
204	20.7	16.6	17.3	19.8	17.4	19.3	19.9	22.7	22.7	16.9	15.9
260	19.6	15.3	16.1	18.5	17.4	19.1	19.3	21.4	21.4	15.7	13.2
316	17.9	14.6	15.1	17.9	17.4	19.1	19.2	19.5	19.5	14.5	10.5
343	17.4	14.4	14.9			19.1	19.0	19.0	19.0		9.1
371	17.4	14.2	14.4			19.1	18.9	18.3	18.3		7.7

Temp °F	Material Group No.										
	1.1	2.1	2.2	2.8	3.2	3.4	3.5	3.7	3.8	3.17	Ti
	psi										
-100		350	350	350	252	350	350	350	350	350	350
-20	350	350	350	350	252	350	350	350	350	350	350
0	350	350	350	350	252	350	350	350	350	350	350
100	350	350	350	350	252	350	350	350	350	350	350
200	319	292	301	336	252	309	332	350	350	303	310
300	310	263	272	310	252	289	310	341	341	271	271
400	300	241	250	287	252	280	288	329	329	245	231
500	284	222	233	268	252	277	280	310	310	228	191
600	260	211	219	259	252	277	278	282	282	210	152
650	253	209	216			277	276	275	275		132
700	253	207	209			277	274	266	266		112

Figure 3-4B Blind Cover Ratings
HOC Pumps

Temp °C	Material Group No.										
	1.1	2.1	2.2	2.8	3.2	3.4	3.5	3.7	3.8	3.17	Ti
	bar										
-73		25.9	25.9	25.9	18.7	25.9	25.9	25.9	25.9	25.9	25.9
-29	25.9	25.9	25.9	25.9	18.7	25.9	25.9	25.9	25.9	25.9	25.9
-18	25.9	25.9	25.9	25.9	18.7	25.9	25.9	25.9	25.9	25.9	25.9
38	25.9	25.9	25.9	25.9	18.7	25.9	25.9	25.9	25.9	25.9	25.9
93	23.7	21.6	22.4	25.0	18.7	22.9	24.6	25.9	25.9	22.5	23.0
149	23.0	19.5	20.2	23.0	18.7	21.4	23.0	25.3	25.3	20.1	20.1
204	22.3	17.9	18.6	21.3	18.7	20.8	21.4	24.4	24.4	18.2	17.1
260	21.1	16.5	17.3	19.9	18.7	20.6	20.8	23.0	23.0	16.9	14.2
316	19.3	15.7	16.3	19.3	18.7	20.6	20.7	21.0	21.0	15.6	11.3
343	18.7	15.5	16.0			20.6	20.4	20.4	20.4		9.8
371	18.7	15.3	15.5			20.6	20.3	19.7	19.7		8.3

Temp °F	Material Group No.										
	1.1	2.1	2.2	2.8	3.2	3.4	3.5	3.7	3.8	3.17	Ti
	psi										
-100		377	377	377	271	377	377	377	377	377	377
-20	377	377	377	377	271	377	377	377	377	377	377
0	377	377	377	377	271	377	377	377	377	377	377
100	377	377	377	377	271	377	377	377	377	377	377
200	343	314	324	362	271	333	357	377	377	326	334
300	334	283	293	334	271	311	334	367	367	292	292
400	323	259	269	309	271	301	310	354	354	264	249
500	306	239	251	288	271	298	301	334	334	245	206
600	280	227	236	279	271	298	299	303	303	226	164
650	272	225	232			298	297	296	296		142
700	272	223	225			298	295	286	286		121



**Figure 3-4C Blind Cover Ratings
Durco Mark 3 GP1 and GP2**

Temp °C	Material Group No.										
	1.1	2.1	2.2	2.8	3.2	3.4	3.5	3.7	3.8	3.17	Ti
	bar										
-73		27.6	27.6	27.6	17.4	24.1	24.1	27.6	27.6	24.1	27.6
-29	27.6	27.6	27.6	27.6	17.4	24.1	24.1	27.6	27.6	24.1	27.6
-18	27.6	27.6	27.6	27.6	17.4	24.1	24.1	27.6	27.6	24.1	27.6
38	27.6	27.6	27.6	27.6	17.4	24.1	24.1	27.6	27.6	24.1	27.6
93	25.2	23.0	23.7	26.5	17.4	21.3	22.9	27.6	27.6	20.9	24.5
149	24.4	20.7	21.5	24.5	17.4	19.9	21.4	26.8	26.8	18.7	21.3
204	23.7	19.0	19.7	22.6	17.4	19.3	19.9	25.9	25.9	16.9	18.2
260	22.4	17.5	18.4	21.1	17.4	19.1	19.3	24.5	24.5	15.7	15.1
316	20.5	16.7	17.2	20.4	17.4	19.1	19.2	22.2	22.2	14.5	12.0
343	19.9	16.5	17.0			19.1	19.0	21.7	21.7		10.4
371	19.9	16.3	16.5			19.1	18.9	21.0	21.0		8.8

Temp °F	Material Group No.										
	1.1	2.1	2.2	2.8	3.2	3.4	3.5	3.7	3.8	3.17	Ti
	psi										
-100		400	400	400	252	350	350	400	400	350	400
-20	400	400	400	400	252	350	350	400	400	350	400
0	400	400	400	400	252	350	350	400	400	350	400
100	400	400	400	400	252	350	350	400	400	350	400
200	365	333	344	384	252	309	332	400	400	303	355
300	354	300	311	355	252	289	310	389	389	271	309
400	343	275	286	328	252	280	288	376	376	245	264
500	324	253	267	307	252	277	280	355	355	228	219
600	297	242	250	296	252	277	278	323	323	210	173
650	289	239	247			277	276	315	315		151
700	289	236	239			277	274	304	304		128

Figure 3-4D Durco Mark 3 Group2-13" Lo-Flo Pumps with Class 300 Flanges

Temp °C	Material Group No.											
	1.0	1.1	2.1	2.2	2.8	3.2	3.4	3.5	3.7	3.8	3.17	Ti
	bar											
-73			31.0	31.0	31.0	17.4	24.1	27.6	31.0	31.0	24.1	31.0
-29	31.0	31.0	31.0	31.0	31.0	17.4	24.1	27.6	31.0	31.0	24.1	31.0
-18	31.0	31.0	31.0	31.0	31.0	17.4	24.1	27.6	31.0	31.0	24.1	31.0
38	31.0	31.0	31.0	31.0	31.0	17.4	24.1	27.6	31.0	31.0	24.1	31.0
93	29.1	28.3	25.9	26.7	29.8	17.4	21.3	26.1	31.0	31.0	20.9	27.5
149	27.4	27.5	23.3	24.1	27.5	17.4	19.9	24.4	30.2	30.2	18.7	24.0
204	25.5	26.6	21.3	22.2	25.4	17.4	19.3	22.7	29.2	29.2	16.9	20.5
260	24.0	25.2	19.7	20.7	23.8	17.4	19.1	22.1	27.5	27.5	15.7	17.0
316	22.5	23.1	18.7	19.4	23.0	17.4	19.1	21.9	25.0	25.0	14.5	13.4
343	21.8	22.4	18.5	19.2			19.1	21.8	24.4	24.4		11.7
371		22.4	18.3	18.5			19.1	21.6	23.6	23.6		9.9

Temp °F	Material Group No.											
	1.0	1.1	2.1	2.2	2.8	3.2	3.4	3.5	3.7	3.8	3.17	Ti
	psi											
-100			450	450	450	252	350	400	450	450	350	450
-20	450	450	450	450	450	252	350	400	450	450	350	450
0	450	450	450	450	450	252	350	400	450	450	350	450
100	450	450	450	450	450	252	350	400	450	450	350	450
200	422	410	375	388	432	252	309	379	450	450	303	399
300	397	398	338	350	399	252	289	354	438	438	271	348
400	369	386	309	322	369	252	280	330	423	423	245	297
500	348	365	285	300	345	252	277	320	399	399	228	246
600	327	334	272	281	333	252	277	318	363	363	210	195
650	316	325	269	278			277	316	354	354		170
700		325	266	269			277	313	342	342		144

4 MAINTENANCE



It is the plant operator's responsibility to ensure that all maintenance, inspection and assembly work is carried out by authorized and qualified personnel who have adequately familiarized themselves with the subject matter by studying this manual in detail. (See also section 1.6.2.)

Any work on the machine must be performed when it is at a standstill. It is imperative that the procedure for shutting down the machine is followed.

If platforms, stairs and guard rails are required for maintenance, they must be placed for easy access to areas where maintenance and inspection are to be carried out. The positioning of these accessories must not limit access or hinder the lifting of the part to be serviced.

When air or compressed inert gas is used in the maintenance process, the operator and anyone in the vicinity must be careful and have the appropriate protection.

Do not spray air or compressed inert gas on skin.

Do not direct an air or gas jet towards other people.

Never use air or compressed inert gas to clean clothes.

Before working on the pump, take measures to prevent the pump from being accidentally started. Place a warning sign on the starting device:
"Machine under repair: do not start."

With electric drive equipment, lock the main switch open and withdraw any fuses. Put a warning sign on the fuse box or main switch:
"Machine under repair: do not connect."

Never clean equipment with flammable solvents or carbon tetrachloride. Protect yourself against toxic fumes when using cleaning agents. Refer to the parts list shown in section 8 for item number references used throughout this section.

4.1 Maintenance schedule



It is recommended that a maintenance plan and schedule be implemented, in accordance with these User Instructions, to include the following:

a) Check for any leaks from gaskets and seals

b) Check that the duty condition is in the safe operating range for the pump.

4.2 Tools required

A typical range of tools that will be required to maintain these pumps is listed below.

Standard hand tools SAE

- Hand wrenches
- Socket wrenches
- Allen wrenches
- Soft mallet
- Screwdrivers

4.3 Examination of parts

Cleaning/inspection

All parts should now be thoroughly cleaned and inspected. New gaskets should be used. Any parts that show wear or corrosion should be replaced with new genuine Flowserve parts.



It is important that only non-flammable, non-contaminated cleaning fluids are used. These fluids must comply with plant safety and environmental guidelines.

5 INSTALLATION

5.1 Pump Power End Removal

 Remove the power end according to the user instruction provided with the pump.

- a) Before performing any maintenance, disconnect the driver from its power supply and lock it off line.

 Lock out power to driver to prevent personal injury.

- b) Close the discharge and suction valves, and drain all liquid from the pump.
- c) Close all valves on auxiliary equipment and piping, then disconnect all auxiliary piping.
- d) Decontaminate the pump as necessary.

 If Flowserve pumps contain dangerous chemicals, it is important to follow plant safety guidelines to avoid personal injury or death.

- e) Remove casing fasteners [6580.1]. On GP1 In-Line pumps the studs [6572.1] must be removed.
- f) Remove the fasteners holding the bearing housing foot to the baseplate (not applicable on In-Line pumps).
- g) Move the power end, rear cover, and seal chamber assembly away from the casing. On In-Line pumps the simplest method of power end removal is to first remove the motor and motor adapter with a crane. However this is often not practical and the power end must be removed by hand
- h) Discard the casing/cover gasket [4590.1].

 The power end and rear cover assembly is heavy. It is important to follow plant safety guidelines when lifting it.

5.2 Casing Blind Cover Installation

- a) Install a new rear cover gasket [4590.1] between the blind rear cover [1220] and the casing [1100].
- b) Use studs [6572.1] and nuts [6580.1] and torque to values found in user instructions provided with the pump.

5.2.1 Pre start-up checks

All fasteners tightened to the correct torque

6 REMOVAL

- a) Before performing any maintenance, disconnect the driver from its power supply and lock it off line.

 Lock out power to driver to prevent personal injury.

- b) Close the discharge and suction valves, and drain all liquid from the pump.
- c) Close all valves on auxiliary equipment and piping, then disconnect all auxiliary piping.
- d) Decontaminate the pump as necessary.

 If Flowserve pumps contain dangerous chemicals, it is important to follow plant safety guidelines to avoid personal injury or death.

- e) Support the cover [1220] with appropriate equipment.
- f) Remove casing fasteners [6580.1]. On GP1 In-Line pumps the studs [6572.1] must be removed.
- g) Move the cover away from the casing.
- h) Discard the casing/cover gasket [4590.1].

 The cover assembly is heavy. It is important to follow plant safety guidelines when lifting it.

7 PARTS LIST AND DRAWINGS

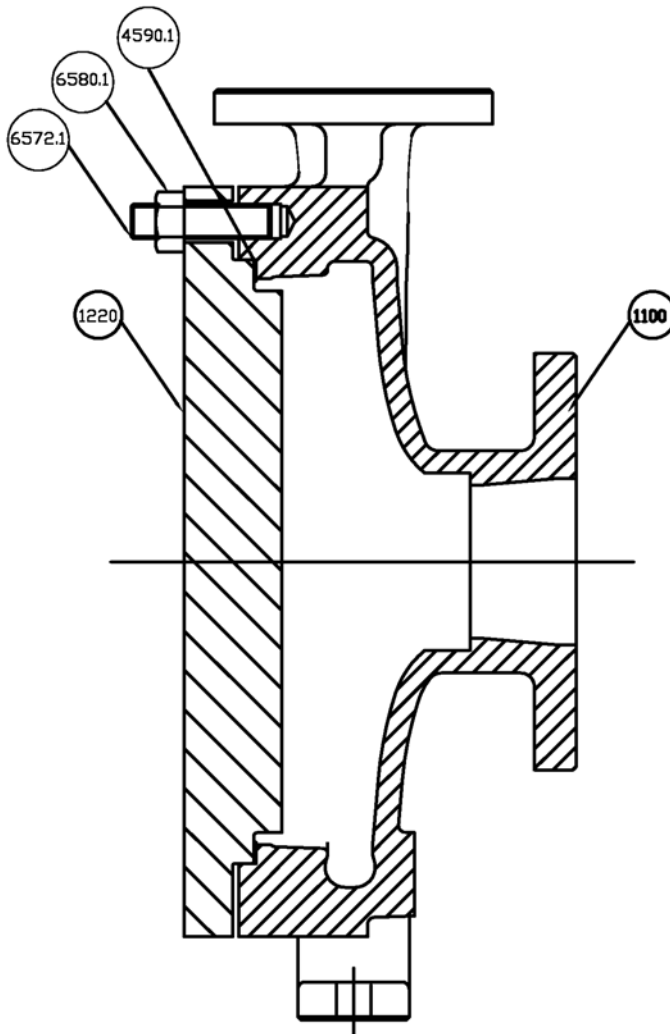

ITEM	PART NAME
1100	CASING
1220	CASING BLIND COVER
4590.1	GASKET, COVER
6572.1	STUD, CASING
6580.1	NUT, CASING

8 CERTIFICATION

Certificates, determined from the contract requirements are provided with these instructions where applicable. Examples are certificates for CE marking and ATEX marking etc. If required, copies of other certificates sent separately to the Purchaser should be obtained from Purchaser for retention with these User Instructions.

9 OTHER RELEVANT DOCUMENTATION AND MANUALS

9.1 Supplementary User Instructions

Supplementary instructions such as for a driver, instrumentation, controller, seals, sealant systems etc are provided as separate documents in their original format. If further copies of these are required they should be obtained from the supplier for retention with these User Instructions.

9.2 Change notes

If any changes, agreed with Flowserve Pump Division, are made to the product after it is supplied, a record of the details should be maintained with these User Instructions.

9.3 Additional sources of information

The following are excellent sources for additional information on Flowserve Mark 3 pumps, and centrifugal pumps in general.

Pump Engineering Manual

R.E. Syska, J.R. Birk,
Flowserve Corporation, Dayton, Ohio, 1980.

Specification for Horizontal End Suction Centrifugal Pumps for Chemical Process, ASME B73.1M

The American Society of Mechanical Engineers,
New York, NY.

Specification for Vertical In-Line Centrifugal Pumps for Chemical Process, ASME B73.2M

The American Society of Mechanical Engineers,
New York, NY.

BLANK

American National Standard for Centrifugal Pumps for Nomenclature, Definitions, Design and Application (ANSI/HI 1.1-1.3)

Hydraulic Institute, 9 Sylvan Way, Parsippany,
New Jersey 07054-3802.

American National Standard for Vertical Pumps for Nomenclature, Definitions, Design and Application (ANSI/HI 2.1-2.3)

Hydraulic Institute, 9 Sylvan Way, Parsippany,
New Jersey 07054-3802.

American National Standard for Centrifugal Pumps for Installation, Operation, and Maintenance (ANSI/HI 1.4)

Hydraulic Institute, 9 Sylvan Way, Parsippany,
New Jersey 07054-3802.

Flowserve Durco Pump Parts Catalog.

Flowserve Mark 3 Sales Bulletin.

Flowserve Mark 3 Technical Bulletin (P-10-501).

RESP73H Application of ASME B73.1M-1991, Specification for Horizontal End Suction Centrifugal Pumps for Chemical Process, Process Industries Practices

Construction Industry Institute, The University of Texas at Austin, 3208 Red River Street, Suite 300,
Austin, Texas 78705.

Pump Handbook

2nd edition, Igor J. Karassik et al, McGraw-Hill, Inc.,
New York, NY, 1986.

Centrifugal Pump Sourcebook

John W. Dufour and William E. Nelson,
McGraw-Hill, Inc., New York, NY, 1993.

Pumping Manual, 9th edition

T.C. Dickenson, Elsevier Advanced Technology,
Kidlington, United Kingdom, 1995.



Your Flowserve factory contacts:

**Flowserve Pump Division
3900 Cook Boulevard
Chesapeake, VA 23323-1626 USA**

Telephone +1 757 485 8000
Fax +1 757 485 8149

**Flowserve Pumps Limited
PO Box 17, Newark, Notts NG 24 3BU
United Kingdom**

Telephone (24 hours) +44 (0)1636 494 600
Sales & Admin Fax +44 (0)1636 705 991
Repair & Service Fax +44 (0)1636 494 833
E-mail inewark@flowserve.com

Your local Flowserve representative:

To find your local Flowserve representative please use the Sales Support Locator System found at www.flowserve.com

FLOWSERVE REGIONAL SALES OFFICES:

USA and Canada

Flowserve Corporation
Pump
5215 North O'Connor Blvd.,
Suite 2300
Irving, Texas 75039-5421 USA
Telephone 1 972 443 6500
Fax 1 972 443 6800

Europe, Middle East, Africa

Worthing S.P.A.
Flowserve Corporation
Via Rossini 90/92
20033 Desio (Milan) Italy
Telephone 39 0362 6121
Fax 39 0362 303396

Latin America and Caribbean

Flowserve Corporation
Pump
6840 Wynnwood Lane
Houston, Texas 77008 USA
Telephone 1 713 803 4434
Fax 1 713 803 4497

Asia Pacific

Flowserve Pte. Ltd
10 Tuas Loop
Singapore 637345
Telephone 65 6771 1600
Fax 65 6779 4607