

**ACCORD**  
CONTROLS



*Actuators and Accessories*

*Accord Controls was founded in 1983 to produce an innovative non-metallic positioner for the pulp-and-paper industry. In 1988, we introduced the UltraSwitch, a compact valve position indicator widely popular today. The Apex 5000 modular positioner burst onto the scene in 1993. Its ease of calibration, modularity and reliability make it a favorite among valve automation shops and process plants alike.*

*Our history as a supplier of quarter-turn valve controls has given us a unique understanding of actuators as well. The actuators on these pages are among the most reliable and flexible available. With torque ranges from 25 to 500,000 inch-pounds, Accord now has a complete line of valve automation equipment. There is simply no need to look anywhere else. Accord products include four lines of positioners and six lines of valve position indicators. From fieldbus valve positioners and controllers to tried-and-true mechanical valve indicators to reliable pneumatic actuators, you won't find a broader range of quarter-turn valve controls. Turn to Accord for all your valve automation needs.*

*Throughout its eighteen-year history, Accord has maintained a commitment to excellence in customer service. Our network of direct sales engineers, reps and distributors are ready to help with all your valve control needs. Provo-based customer service and application engineering staff are also available to assist with identifying the best Accord products for your demanding valve control problems.*



**Quality, Dependability, and Productivity.**

Accord's pneumatic actuators can automate valves with torque values from 25 to 500,000 in-lb. Actuators are available in a wide range of materials suitable for use in the most demanding applications. Accord also offers a comprehensive range of NAMUR Controls and accessories such as lockout modules and gear overrides.



**SuperNova  
AB-Series**

Pages 4-8

SuperNova AB series Rack and Pinion actuators are designed for butterfly, plug or ball valves, and offer one compact design for double acting and spring return. Precision die-cast pistons with large cylinder bearings increase efficiency and cycle life. Available in torque ranges from 25 in-lb to 58,000 in-lb, for optimum actuator sizing.



**Controls &  
Accessories**

Page 9

The actuator is the heart of an automation system, but control accessories are important in creating a complete system to meet increasingly sophisticated customer requirements. Solenoid valves and related accessories with NAMUR interfaces provide direct, modular mounting on actuator. Switches, and Positioners can also be integrated into the assembly. AutoBrakits are engineered to assure consistency and proper alignment.



**Heavy Duty  
AR2, AR3, AR4 &  
AR5 Series**

Pages 10-15

A complete line of Scotch Yoke heavy-duty actuators provide torques from 3,000 to 500,000 in-lb. The combination of Scotch Yoke actuators plus Rack and Pinion actuators offers the opportunity to standardize on one source for your complete quarter-turn automation needs. Scotch Yoke Actuators can also be configured with high pressure hydraulic cylinders. Contact Accord for complete details.

## SuperNova AB-Series Spring Return



Broad size range offers optimum actuator sizing for each valve requirement.

*Rack & Pinion Actuators are designed for automating butterfly, plug or ball valves and dampers. The actuators incorporate a precision-extruded hard anodized aluminum body and a one piece nitride-coated pinion gear, supported by top and bottom bearings and factory lubricated for a long trouble free life. Actuators are designed for 100 degree travel with clockwise and counterclockwise travel adjustment for open and closed positions. Actuators are convertible to a double acting or a spring return simply by removing or adding springs, while utilizing the same body and end caps. Available in torque ranges from 25 in-lbs. to 58,000 in-lbs., for optimum actuator sizing for each valve requirement.*

Field reversible action simply by rotating pistons 180°

One compact design for double acting and spring return is easily field-convertible by installing or removing springs.

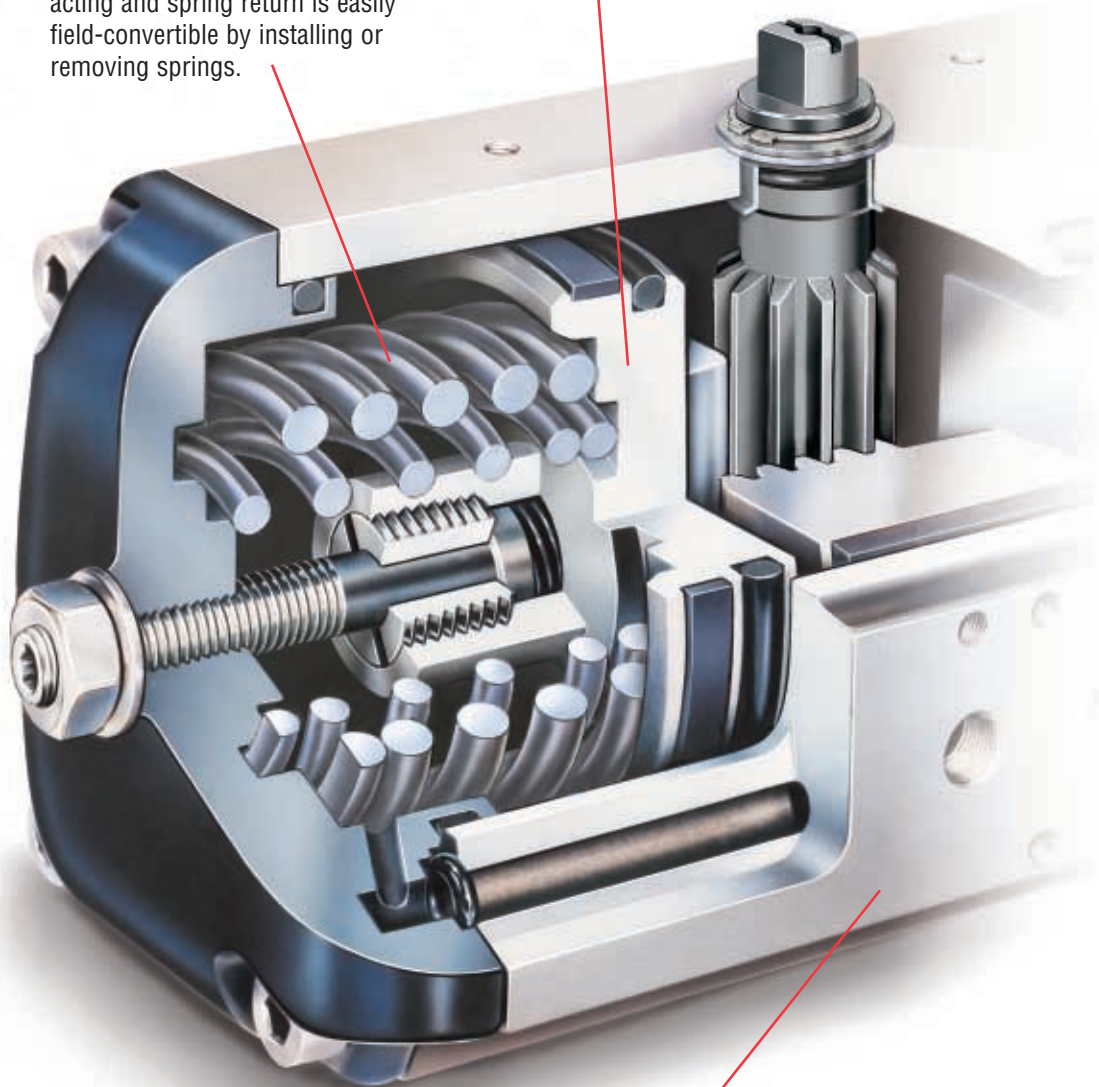

Corrosion resistant hard anodized aluminum housings with stainless steel fasteners.



**SuperNova AB-Series Double Acting**

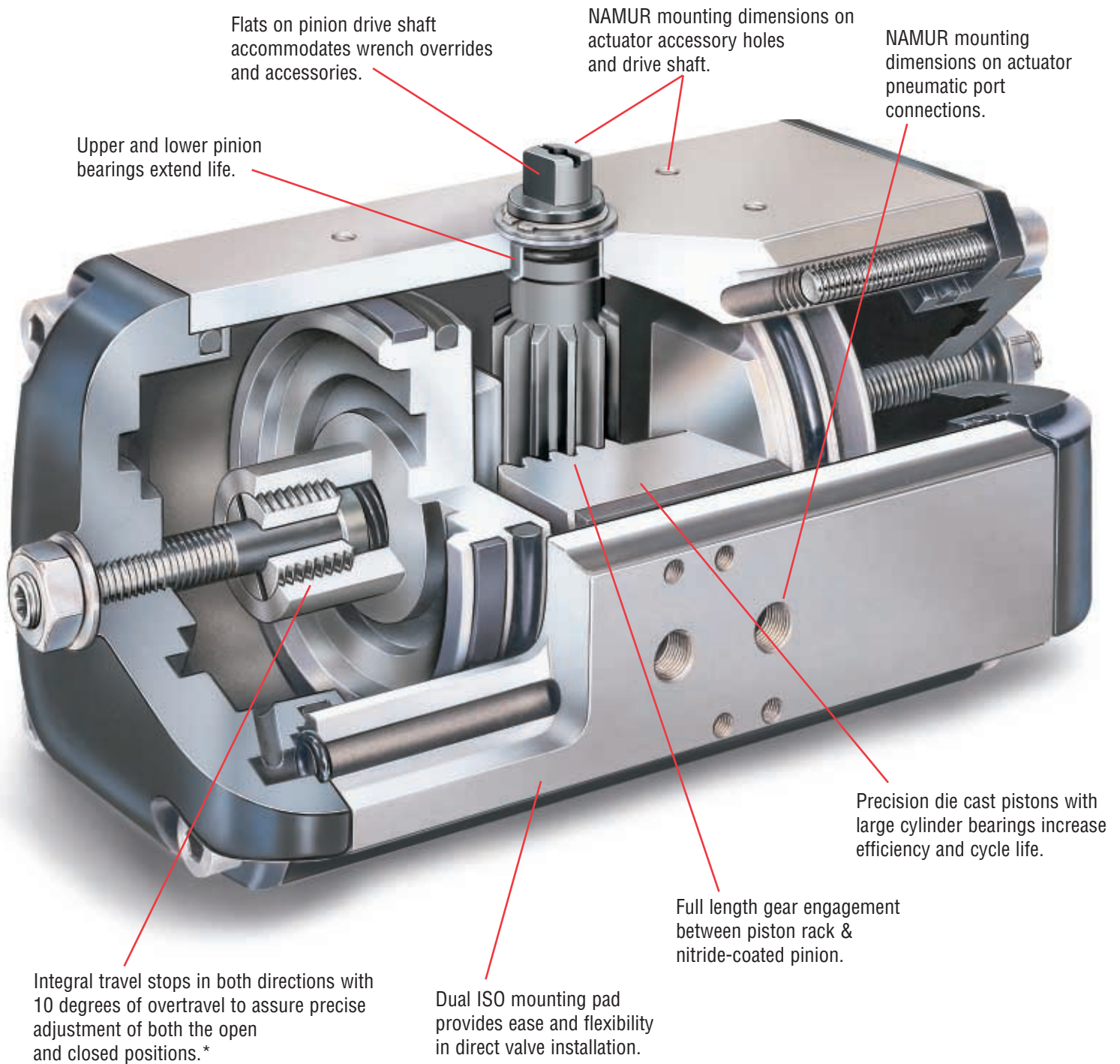

\*Outward piston adjustment only on models ASAP250 & ASAP300

## SuperNova AB-Series Torque Outputs

Model	Spring			Air Supply						
	No	End	Break	60 Psig		80 Psig		100 Psig		
AB050	5	36	55	56	76					
	6	43	64	46	69					
	7	49	73	35	63	74	102			
	8	61	92	15	49	54	88	93	127	
	9	73	110			34	74	73	113	
	AB063	6	68	102	103	141				
		7	79	119	85	128				
		8	90	136	66	116				
		9	102	153			119	175		
		10	113	170			100	163		
		11	124	186			82	150	153	222
		12	135	203					135	210
AB085		6	141	211	215	293				
		7	164	246	177	267				
		8	188	282	138	241				
		9	211	317			248	365		
		10	235	352			209	339		
	11	258	387			171	313	320	463	
	12	282	422					281	437	
	AB100	6	260	390	397	541				
		7	303	455	325	493				
		8	347	520	253	445				
		9	390	585			457	673		
		10	433	651			385	625		
11		477	716			313	577	589	853	
12		520	781					518	805	
AB115		6	430	645	656	894				
		7	502	753	537	814				
		8	573	860	418	735				
		9	645	968			756	1112		
		10	717	1075			637	1033		
	11	789	1183			518	954	975	1410	
	12	860	1290					856	1331	
	AB125	6	610	915	930	1267				
		7	712	1067	761	1155				
		8	813	1220	593	1042				
		9	915	1372			1071	1577		
		10	1017	1525			903	1464		
11		1118	1677			734	1352	1381	1999	
12		1220	1830					1213	1887	

Note: For additional air supply pressures, consult factory or your AutoSize software program.

### DA Torque

Actuator	Air Pressure (psi)				
	40	60	80	100	150
A32	25	37	50	62	93
AB050	78	116	155	194	291
AB063	144	216	288	360	539
AB085	299	449	598	748	1122
AB100	552	828	1104	1380	2071
AB115	913	1369	1826	2282	3423
AB125	1294	1941	2588	3236	4853
AB150	2329	3494	4658	5823	8734
AB175	3487	5230	6974	8717	13076
AB200	4970	7455	9940	12424	18637
ASAP250	10354	15531	20707	25884	38826
ASAP300	15529	23293	31057	38822	58232

Model	No	Air Supply								
		Spring		60 Psig		80 Psig		100 Psig		
AB150	6	1098	1648	1673	2280					
	7	1281	1922	1369	2078					
	8	1465	2197	1066	1875					
	9	1648	2471			1927	2837			
	10	1831	2746			1624	2635			
	11	2014	3020			1320	2432	2485	3597	
	12	2198	3295					2182	3394	
	AB175	6	1606	2527	2438	3457				
		7	1899	2907	2079	3133				
		8	2153	3349	1530	2851				
		9	2427	3759			2820	4292		
		10	2701	4170			2366	3989		
11		2975	4581			1912	3686	3656	5430	
12		3249	4992					3201	5127	
AB200		6	2343	3516	3568	4864				
		7	2734	4107	2914	4432				
		8	3125	4691	2269	4000				
		9	3515	5277			4106	6053		
		10	3906	5865			3456	5622		
	11	4296	6451			2808	5190	5293	7674	
	12	4687	7037					4645	7243	
	ASAP250	6	2854	6591	7421	12025				
		7	3393	7690	6448	11441				
		8	3945	8788	5428	10857				
		9	4519	9887	4373	10273	9780	15450		
		10	5106	10985	3274	9689	8566	14866		
11		5715	12084			7352	14281	12529	19458	
12		6343	13182			6138	13697	11314	18874	
ASAP300		6	4744	11096	9931	17473				
		7	5640	12945	8245	16501				
		8	6558	14795	6482	15530				
		9	7512	16644	4658	14559	12669	22326		
		10	8487	18493	2762	13588	10625	21355		
	11	9500	20343			8581	20384	16348	28150	
	12	10543	22192			6537	19412	14304	27179	

### Spring chart AB050 ②

Spring Group	Spring Combination ①		
	#1 Spring (inner)	#2 Spring (low rate outer)	#3 Spring (high rate outer)
4	1 ③	1 ③	
5		2	
6	2	1	
7	1	2	
8	2	2	
9	2		2

Note: ① #1 Spring has one color code dot  
 #2 Spring has two color code dots ② AB050 has maximum of 2 springs per endcap  
 #3 Spring has three color code dots ③ Install springs on opposite sides

### Spring chart AB063-AB200

Spring Group	#1 Spring (inner)	Spring Combination ①	
		#2 Spring (middle)	#3 Spring (outer)
4		2	
5		1 ③	1 ③
6			2
7	1		2
8	2		2
9	1 ③	1 ③	2
10		2	2
11	1	2	2
12	2	2	2

### ASAP250-ASAP300 Spring Combinations

Spring number is total number of springs in endcaps. There should never be a difference in springs per endcap greater than one. Example: ASAP250S09 would have four springs in one endcap and five in the other.

## SuperNova AB-Series Dimensions

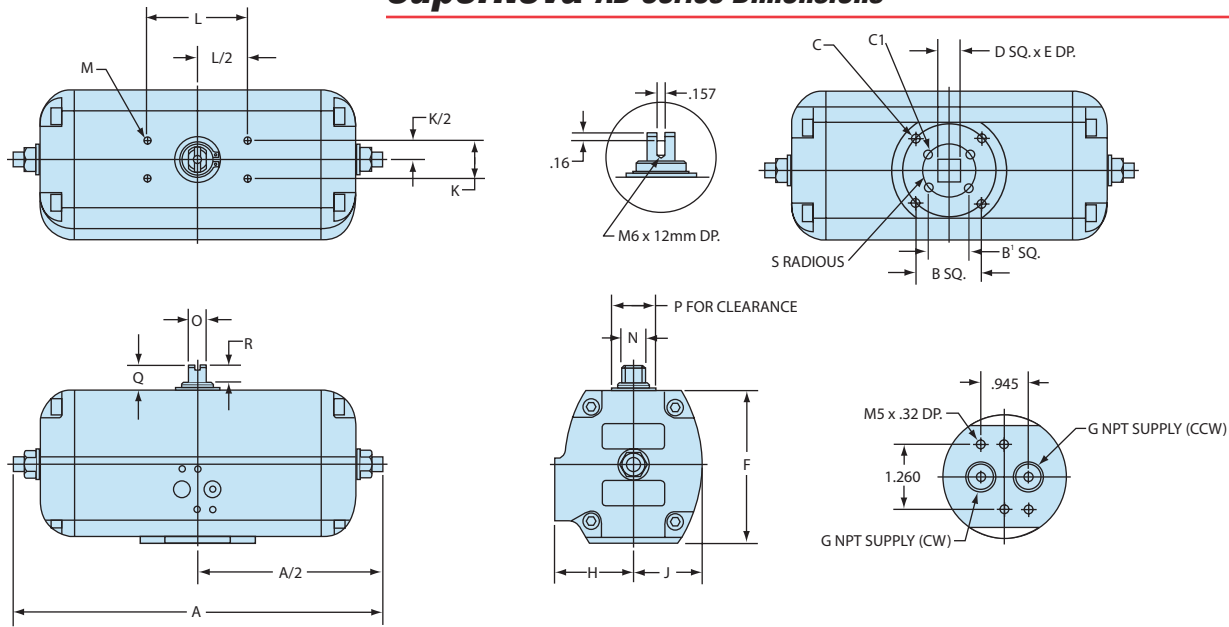

- ① Actuator shown in the full clockwise (CW) position as viewed from top.
- ② Accessory mounting holes not for gear override or stop block.
- ③ Cycle times under no load conditions. Air line size, air capacity, and valve torque characteristics affect these cycle times. Faster or slower cycle times can be accomplished using special control components.

Model	ISO	A		B SQ.	B' SQ.	C	C'	D	E	F	G NPT	H	J	K	L	M <sup>②③</sup>	N	O	P	Q	R	Weights (LBS)		Volume (in)		Cycle Time	
		DA&SR	180																			DA	SR	CW	CCW	CW	CCW
AB050	F04S11E	6.69	8.70	1.169	N/A	#10-24x.31 <sup>③</sup>	N/A	.443	.47	2.56	1/8	1.58	1.14	1.181	3.150	#10-24	.47	.394	.75	.79	.39	2.7	3.1	8.2	5.4	.5	.5
AB063	F03/F05S14E	7.95	9.92	1.392	1.002	1/4-20x.31 <sup>③</sup>	#10-24x.31	.551	.63	3.19	1/8	1.77	1.40	1.181	3.150	#10-24	.47	.394	.88	.79	.39	3.8	4.4	16	10	.5	.5
AB085	F05/F07S17E	9.84	12.13	1.949	1.392	5/16-18x.31 <sup>③</sup>	1/4-20x.31	.669	.75	4.15	1/8	2.24	1.87	1.181	3.150	#10-24	.77	.551	1.00	.79	.55	7.5	9.3	34	20	.5	.5
AB100	F05/F07S17E	11.65	14.80	1.949	1.392	5/16-18x.31 <sup>③</sup>	1/4-20x.31	.669	.75	4.80	1/4	2.48	2.17	1.181	3.150	#10-24	.77	.551	1.38	.79	.55	11.5	14.6	56	38	1	.5
AB115	F07/F10S22E	13.47	17.60	2.840	1.949	3/8-16x.39	5/16-18x.31	.866	.98	5.30	1/4	2.91	2.46	1.181	5.118	#10-24	1.10	.787	1.63	1.18	.79	17.7	22.5	94	65	1	1
AB125	F07/F10S22E	15.83	20.35	2.840	1.949	3/8-16x.39	5/16-18x.31	.866	.98	5.79	1/4	3.07	2.68	1.181	5.118	#10-24	1.10	.787	2.00	1.18	.79	23.8	30.2	128	90	1	1
AB150	F10/F12S27E	19.13	25.20	3.480	2.840	1/2-13x.45	3/8-16x.39	1.063	1.18	6.85	1/4	3.47	3.19	1.181	5.118	#10-24	1.87	1.417	2.38	1.18	.89	40.8	51.2	224	159	2.0	1.5
AB175	F10/F14S36E	21.34	28.58	3.897	2.840	5/8-11x.63	3/8-16x.39	1.417	1.57	8.21	1/4	4.17	3.74	1.181	5.118	#10-24	1.87	1.417	2.75	1.18	.89	63.7	77.2	351	232	3.0	2.0
AB200	F10/F14S36E	24.41	31.69	3.897	2.840	5/8-11x.63	3/8-16x.39	1.417	1.57	9.39	1/4	4.72	4.25	1.181	5.118	#10-24	1.97	1.417	2.94	1.18	.89	91.5	118	507	332	4.5	3.0

Note: Double Acting  
 Pressure at port "CW" will result in clockwise rotation. Pressure at Port "CCW" will result in counter-clockwise rotation.  
 Note :Spring Return  
 Pressure at Port "CCW" will result in counter-clockwise rotation. Springs provide clockwise rotation upon loss of pressure.

### How To Order (Select Bold Type Code from each column that applies)

MODEL	TYPE	Springs (Select One) ①	Seals	Materials	Options
AB050	<b>D</b> Double Acting	<b>04</b>	<b>Blank</b> - Buna (Std.)	<b>Blank</b> - Std. Hard Anodized Aluminum	<b>R</b> Extra Long Stop
AB063	<b>S</b> Spring Return (FCW)	<b>05</b>	<b>L</b> Low Temp.		<b>S</b> Stainless Steel Pinion/Snap Ring
AB085	<b>C</b> Spring Return (FCCW)	<b>06</b>	<b>H</b> Viton (High Temp.)	<b>K</b> K-Mass Coated	
AB100	<b>M</b> 180° Double Acting	<b>07</b>		<b>W</b> White Epoxy Coated	
AB115		<b>08</b>		<b>G</b> Gray Epoxy Coated	
AB125		<b>09</b>			
AB150		<b>10</b>			
AB175		<b>11</b>			
AB200		<b>12</b>			
ASAP250					
ASAP300					

① Consult torque charts or AutoSize for applicable spring combinations.  
 Example: A model AB100 spring return (FCW) spring set 10 would be **AB100S10**

## SuperNova Models ASAP250 & ASAP300 90° Units and 180° Actuators

### Dimensions

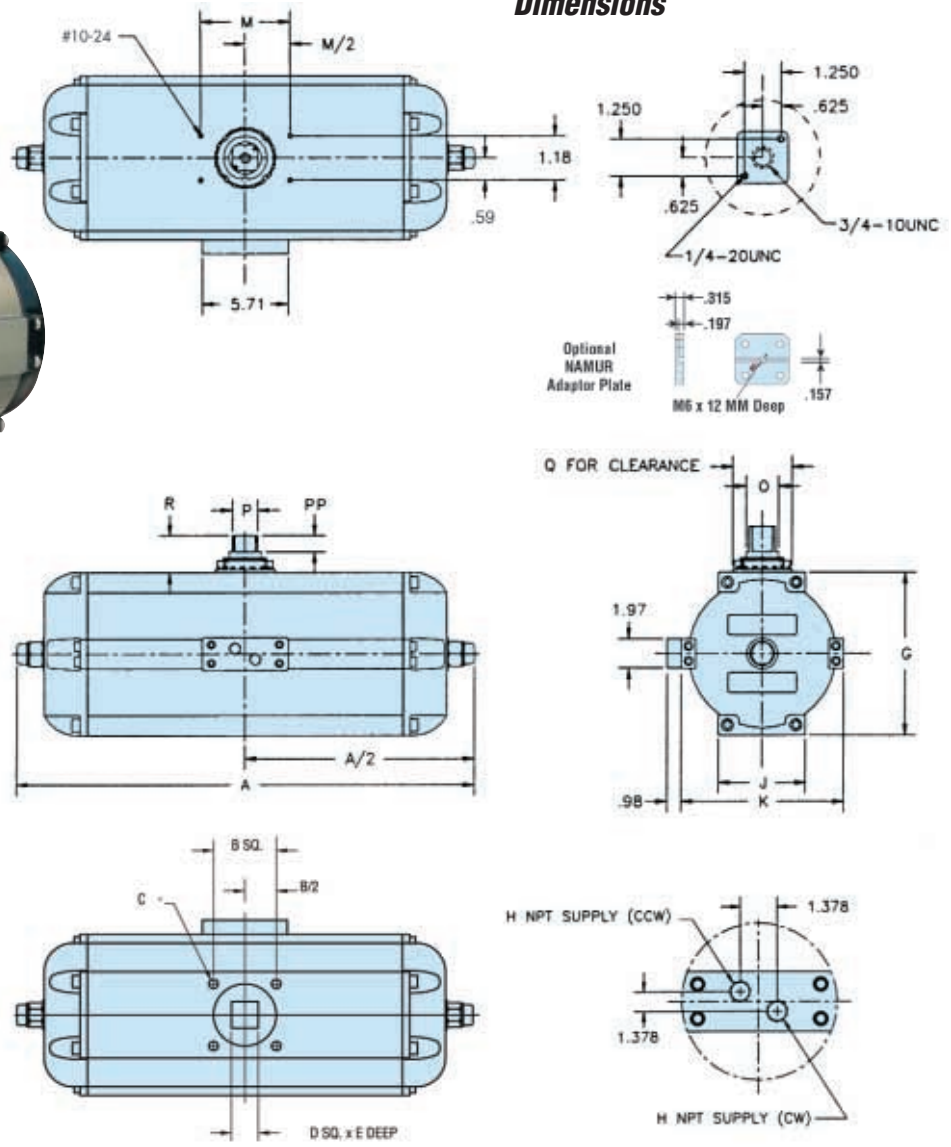

- ① Actuator shown in the full clockwise (CW) position as viewed from top.
- ② Accessory mounting holes not for gear override or stop block.
- ③ Use studs only to mount. Bolts not recommended.
- ④ Cycle times under no load conditions Air line size, air capacity, and valve torque characteristics affect these cycle time. Faster or slower cycle times can be accomplished using special control components.

MODEL	ISO	A		B	C	D	E	G	H	J	K	L	M	N <sup>②③</sup>	O	P	PP	Q	R	WEIGHTS <sup>(IN)</sup>		VOLUME <sup>(LBS)</sup>	
		DA&SR	180																	DA	SR	CW	CCW
ASAP250	F16S46E	27.32	39.14	4.593	3/4-10UNC x.71	1.811	1.97	11.02	1/2	5.91	11.02	1.181	5.118	#10-24	2.20	1.969	0.98	3.75	1.65	137	172	757	720
ASAP300	F16S46E	32.60	44.00	4.593	3/4-10UNC x.71	1.811	1.97	13.39	1/2	6.30	13.39	1.181	5.118	#10-24	2.44	1.969	0.98	3.75	1.65	217	288	1403	1019

For "How To Order" see page 7



## SuperNova AB-Series Controls and Accessories

### Controls



**A25N Directional Valve\***  
The Accord Directional Valve mounts directly to SuperNova series actuators which eliminates the cost of tubing and fittings. The valves are available for double acting and spring return actuators with NEMA 4X, 7 & 9, or intrinsically-safe and low power solenoid operators. These valves have been tested and proven reliable for over 1 million cycles.



**APS1 Module\***  
The Accord APS1 module works with the Accord A25N solenoid valve and diverts exhaust air from between the pistons into the spring chamber. This prevents corrosive atmospheres from being pulled into the spring chamber.



**APS2 Module\***  
The Accord APS2 module works with remote/line mounted solenoid valves and diverts exhaust air from between the pistons into the spring chamber. This prevents corrosive atmospheres from being pulled into the spring chamber.



**LV1 Lockout & Vent Valve\***  
The LV1 Lockout and Vent Valve module provides two primary functions. The LV1 may be used with a manual override to shut off supply air and vent actuator ports. The LV1 may also be used as a pneumatic lockout valve which, when properly implemented, will satisfy OSHA Standard 1910.47. The LV1 may be sandwich mounted with other Accord NAMUR accessories or may be used with the NPT1 adaptor.



**FC1, FCDA & FCSR\***  
The 'FC' Series Flow Control modules provide compact flow controls for precise adjustment of SuperNova actuator speeds. The Flow Control Modules may be sandwich mounted with other Accord accessories or may be used with the NPT1 adaptor.

### Accessories

**"Pharos" NAMUR Indicator\***  
Provides an economical solution for positive visual indication of the actuator position. Constructed of tough industrial engineered resin, the "Pharos" NAMUR indicator can be used on actuators that utilize a NAMUR mounting interface.



**UltraSwitch GL/XL/PL Series Rotary Position Indicators\***  
The UltraSwitch series of position indicators provides a compact and economical package for both visual and remote electrical indication of valve position. Models are available in both die cast aluminum and non-metallic versions. Suitable for non-hazardous, hazardous and intrinsically-safe applications.



**Aviator and BUSwitch Rotary Position Indicator with Internal Pilot Solenoid\***  
The Aviator rotary position indicator enclosure with internal pilot solenoid coil provides a truly integrated package. It can easily be configured with a Field Bus communication card for digital networking.

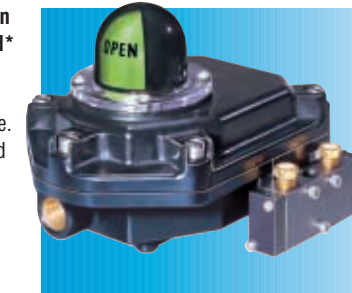

**APEX Modular Positioner\***  
Available in both aluminum and non-metallic versions, the Apex positioner combines precise valve positioning with advanced features. A modular manifold base allows 3-15psi pneumatic control signals, or 4-20mA signals with the addition of the I/P module. Models are available for corrosion resistant applications and hazardous locations as defined by FM, GENELEC, and SAA.



**AutoBrakits\***  
Accord heavy-duty mounting kits are designed to close tolerances to assure consistency and proper alignment, which are essential to ensure maximum actuator and valve cycle life.

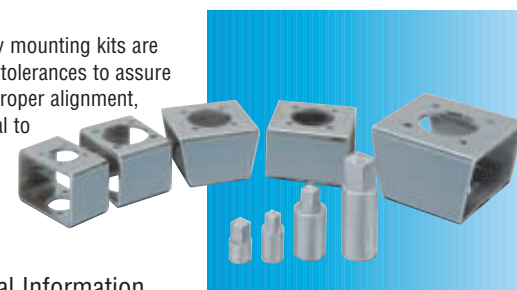

\* Consult Individual Catalogs and IOM's For Additional Information

**Heavy Duty AR2, AR3 and AR4 Series**



Accord has a complete line of scotch yoke, heavy duty rotary actuators, which has a unique bearing design to provide higher efficiencies and longer life.

- Double Acting, Spring Return and “Fail-Safe”
- On-Off, Multi-position and Throttling
- Pressure Ranges from 40 psig to 100 psig
- Torque Outputs: Standard Design from 1000 to 170,000 inch pounds
- Overrides, Special Controls, Line Break Controls, etc.

**Piston Rods and Rod Bearings**

Large diameter piston rods are guided and supported by extra long bronze bearings. The rods are ground, high strength steel with a hard chrome plating polished to a mirror finish of 4 to 8 microns.

**Scotch Yoke**

The slot in the scotch yoke mechanism is precision machined. The yoke pin is induction hardened and chrome plated. The yoke pin rollers are hardened steel.

**Needle Bearings and Seals**

Precision drawn cup needle bearings located at the torque shaft journals significantly increase torque output and cycle life, while providing near frictionless rotary movement. The seals protect the needle bearings from external dirt and corrosion, while the bearing’s rigid design prolongs seal life.

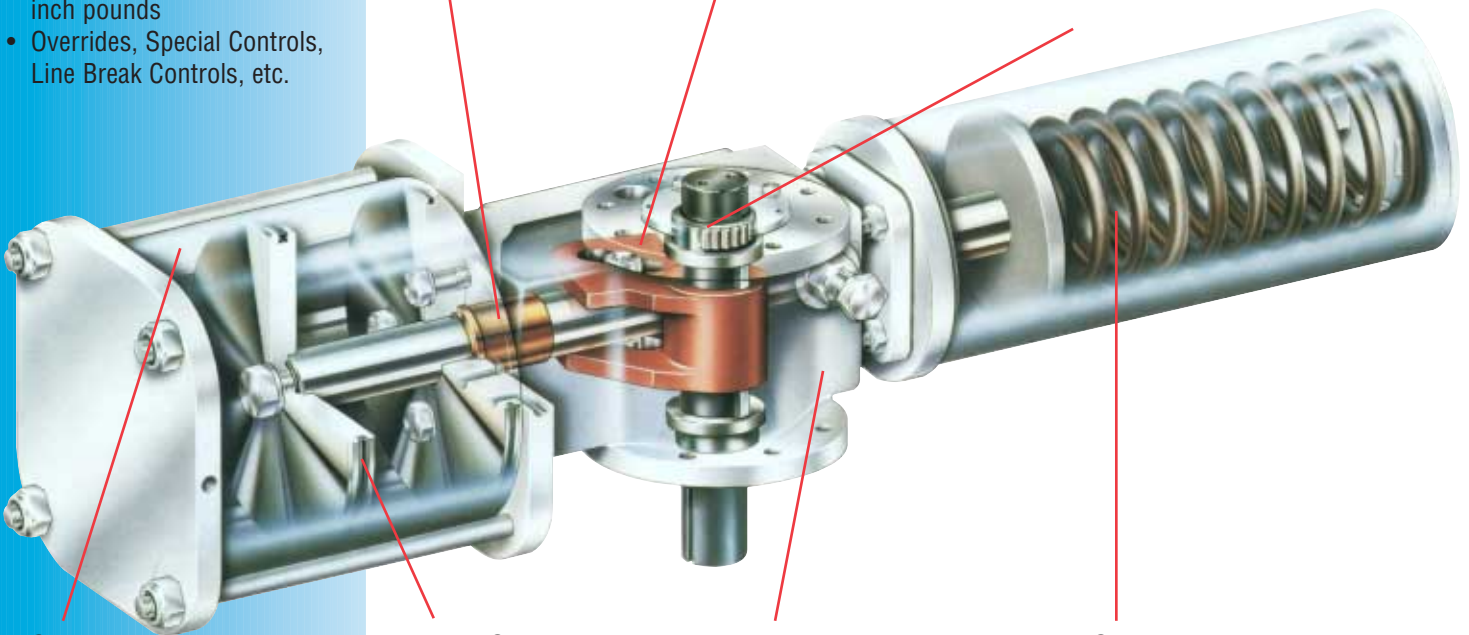

**Cylinders**

The cylinders are honed to a micro finish with a hard chrome plating.

**Piston Seals**

The pneumatic series actuators utilize a quad seal. This seal has proven dependable in years of trouble free service.

**Housing**

This unique one piece housing assures accurate alignment of both the torque shaft and the piston rod.

**Spring Module**

The spring module is an easily removeable, welded cartridge.

**Heavy Duty AR5 Series**

**Piston Seal and Wearband**

The pneumatic series actuators utilize a quad seal in conjunction with a piston wearband. The quad seal provides a low friction, long lasting seal, proven dependable for years of trouble free service. The wearband provides additional alignment and support for the piston seal.

**Scotch Yoke**

The slot in the scotch yoke mechanism is precision machined. The yoke pin is induction hardened and chrome plated. It is supported at the top and bottom by a guide slot in the housing and the yoke pin rollers are hardened steel.

**Indicator/Output shaft**

Top accessory shaft has NAMUR slot, and optional position indicator.

The AR5 Series Heavy Duty Scotch Yoke Actuator provides torque output as high as 500,000 in-lb.

- Double Acting, Spring Return and "Fail-Safe"
- On-Off, Multi-position and Throttling
- Pressure Ranges from 40 psig to 100 psig

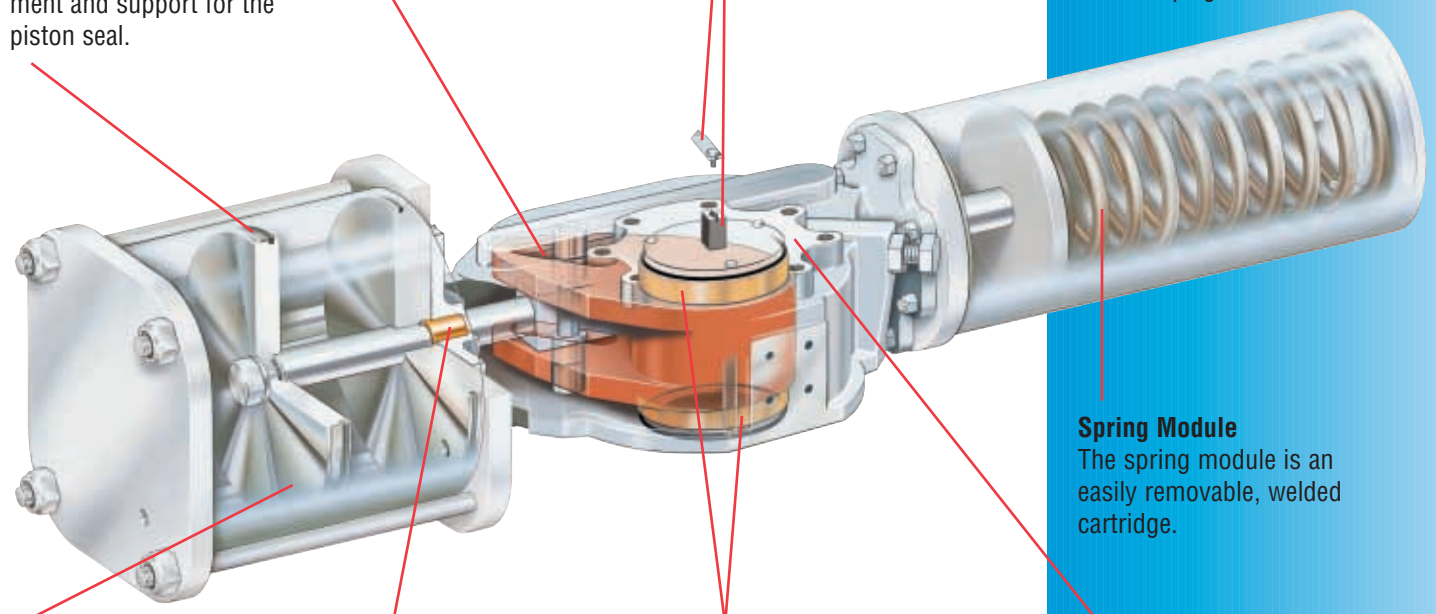

**Cylinders**

The cylinders are honed to a micro finish with a hard chrome plating.

**Piston Rods and Rod Bearings**

Piston rods are guided and supported by self lubricating bronze bearings. The rods are ground, high strength steel with a hard chrome plating, polished to a mirror finish.

**Bearings and Seals**

Large diameter bronze/teflon bearings provide a smooth, low friction surface for the yoke journal. The seals protect the bearings from external dirt and corrosion, while the bearing's rigid design prolongs seal life.

**Spring Module**

The spring module is an easily removable, welded cartridge.

**Identical Mounting Pads**

Valve and accessory mounting pads are located on top and bottom of the body, providing easy change of fail direction and optional mounting of gear override. Two additional mounting pads are available on the side of the body for mounting accessories.

## Heavy Duty Torque Charts

### Double Acting

Model	Torque	40	60	80	100
AR205	Break	3302	4953	6604	8255
	Run	1865	2798	3731	4663
AR206	Break	4899	7348	9797	12246
	Run	2767	4151	5535	6918
AR207	Break	6785	10178	13571	16963
	Run	3833	5750	7667	9583
AR208	Break	8962	13444	17925	
	Run	5063	7595	10126	NA
AR310	Break	13607	20411	27214	34018
	Run	7687	11531	15374	19218
AR312	Break	19993	29990	39990	49985
	Run	11295	16940	22590	28240
AR314	Break	27541	41310	55080	
	Run	15560	23340	31120	NA
AR316	Break	36250	54375		
	Run	20480	30720	NA	NA
AR414	Break	40005	60010	80010	100010
	Run	22600	33900	45200	56500
AR416	Break	53070	79600	106135	132670
	Run	29980	44970	59960	74950
AR418	Break	67870	101810	135745	169680
	Run	38343	57515	76685	95860
AR420	Break	84420	126630	168835	
	Run	47690	71540	95380	NA
AR422	Break	102706	154059		
	Run	58022	87033	NA	NA

### Spring Return

Model	Torque	40	60	80	100
AR205SR	Pneumatic Break	2297	3447	4594	5668
	Pneumatic End	1244	1922	2474	2954
	Spring Break	2291	3379	4595	5882
	Spring End	1237	1854	2475	3168
AR206SR	Pneumatic Break	3235	4961	6543	8268
	Pneumatic End	1710	2842	3829	4197
	Spring Break	3379	4793	6349	8527
	Spring End	1854	2673	3636	4455
AR207SR	Pneumatic Break	4452	6755	9003	10987
	Pneumatic End	2333	4041	4932	5560
	Spring Break	4595	6349	8923	11759
	Spring End	2475	3636	4851	6331
AR208SR	Pneumatic Break	5880	8721	11764	14704
	Pneumatic End	3166	4649	6337	7927
	Spring Break	5882	8923	11759	14692
	Spring End	3168	4851	6331	7915
AR310SR	Pneumatic Break	9187	13785	18379	22824
	Pneumatic End	4958	7683	9226	10350
	Spring Break	9189	13522	19049	24993
	Spring End	4950	7420	9895	12519
AR312SR	Pneumatic Break	12937	19849	26167	33083
	Pneumatic End	6835	10696	13693	16451
	Spring Break	13522	19841	27022	34443
	Spring End	7420	10687	14548	17811
AR314SR	Pneumatic Break	17813	27015	36023	43937
	Pneumatic End	8660	14541	19391	22229
	Spring Break	19049	27022	36027	47043
	Spring End	9895	14548	19395	25335
AR316SR	Pneumatic Break	23672	34892	47047	
	Pneumatic End	11198	18260	25339	
	Spring Break	24993	36027	47043	NA
	Spring End	12519	19395	25335	
AR414SR	Pneumatic Break	27017	40522	54034	65906
	Pneumatic End	14563	21811	29613	34984
	Spring Break	27000	40534	53514	68924
	Spring End	14546	21823	29092	38002
AR416SR	Pneumatic Break	35285	52338	70571	87623
	Pneumatic End	16574	27916	39649	46374
	Spring Break	37712	53514	68924	89343
	Spring End	19001	29092	38002	48094
AR418SR	Pneumatic Break	44656	65057	89320	111651
	Pneumatic End	20235	34036	48070	60743
	Spring Break	48472	68924	89343	111024
	Spring End	24050	38002	488094	60115
AR420SR	Pneumatic Break	55731	82705	109531	137834
	Pneumatic End	31309	41456	58622	74229
	Spring Break	53514	85779	111024	137828
	Spring End	29092	44530	60115	74223
AR422SR	Pneumatic Break	64633	101472	131049	
	Pneumatic End	33712	50564	67443	
	Spring Break	68924	103390	137828	NA
	Spring End	38002	52481	74223	

## Heavy Duty Torque Charts

### AR5 Pneumatic Double Acting Torques

Model	Torque	40	60	80	100
AR514DA	Break	73978	110967	147956	184945
	Run	44083	66124	88166	110207
AR516DA	Break	97370	146056	194741	243426
	Run	58022	87033	116044	145055
AR518DA	Break	123882	185822	247763	309704
	Run	73820	110730	147640	184550
AR51414DA	Break	150393	225589	300786	375982
	Run	89618	134426	179235	224044
AR520DA	Break	153512	230268	307024	383780
	Run	91476	137214	182952	228691
AR51614DA	Break	173785	260678	347570	434463
	Run	103557	155335	207114	258892
AR522DA	Break	186261	279392	372522	465653
	Run	110991	166487	221982	277478
AR51616DA	Break	197177	295766	394355	492944
	Run	117496	176244	234992	293740
AR524DA	Break	222129	333194	444258	NA
	Run	132365	198547	264729	
AR51816DA	Break	223689	335533	447377	NA
	Run	133294	199941	266588	
AR51818DA	Break	250200	375300	500400	NA
	Run	149092	223638	298183	
AR52020DA	Break	309460	464191	NA	NA
	Run	184404	276607		

### AR5 Pneumatic Spring Return Torques

Model	Torque	40	60	80	100
AR516SR	Pneumatic Break				156005
	Pneumatic End				85871
	Spring Break	NA	NA	NA	148061
	Spring End				88837
AR518SR	Pneumatic Break	82154	119224	159124	200290
	Pneumatic End	39519	66535	88990	113660
	Spring Break	78533	111234	148061	182885
	Spring End	41956	66740	88837	109731
AR520SR	Pneumatic Break	98195	149578	196391	250315
	Pneumatic End	54881	79902	109761	145647
	Spring Break	91442	139352	182885	220965
	Spring End	54865	80127	109731	132579
AR522SR	Pneumatic Break	118445	189534	237839	304023
	Pneumatic End	65755	119400	133171	178232
	Spring Break	111234	148061	220965	265558
	Spring End	66740	88837	132579	159335
AR524SR	Pneumatic Break	140221	221343	281411	364896
	Pneumatic End	70545	134713	155620	217507
	Spring Break	139352	182885	265558	311154
	Spring End	80127	109731	159335	186693
AR52214SR	Pneumatic Break	171600	258112	333706	438098
	Pneumatic End	101466	153445	186318	269586
	Spring Break	148061	220965	311154	355748
	Spring End	88837	132579	186693	213449
AR52416SR	Pneumatic Break	208867	318838	424063	
	Pneumatic Break	122237	193047	255551	
	Spring Break	182885	265558	355748	NA
	Spring End	109731	159335	213449	

### How To Order (Select **Bold Type Code** from each column that applies)

Model	Cylinder Size	Type	Spring Size	Override	Temperature	Material/Coating
<b>AR2</b>	05-5" dia.	<b>DA</b> - Double Acting	<b>Blank</b> - DA	<b>Blank</b> -None	<b>Blank</b> - Standard -20° to 175° F (nitrile seals).	<b>Blank</b> - Standard; Epoxy with Polyurethane top coat <b>E</b> - Epoxy paint (white)
	06-6" dia.	<b>SR</b> - Spring Return FCW	<b>40</b> - 40 psi air supply	<b>G</b> - Declutchable gear	<b>V</b> - High Temp. 0° to 300° F (viton seals).	
	07-7" dia.					
	08-8" dia.					
<b>AR3</b>	10-10" dia.	<b>SO</b> - Spring Return FCCW	<b>60</b> - 60 psi air supply (nitrile seals, heat treated body)	<b>J</b> - Jackscrew	<b>L</b> - Low Temp. -55° to 175°F	
	12-12" dia.					
	14-14" dia.					
	16-16" dia.					
<b>AR4</b>	14-14" dia.		<b>80</b> - 80 psi air supply			
	16-16" dia.					
	18-18" dia.					
	20-20" dia.					
<b>AR5</b>	22-22" dia.		<b>100</b> - 100 psi air supply			
	14-14" dia.					
	16-16" dia.					
	18-18" dia.					
	20-20" dia.					
	22-22" dia.					
	24-24" dia.					

Example: A model AR310 spring return (FCW) with 60 psi air supply and viton seals would be: **AR310SR60V**

Note: In some instances for the AR5 actuator, a second cylinder size is required to complete the model number. Consult torque charts.

## Dimensions, Volumes and Weights

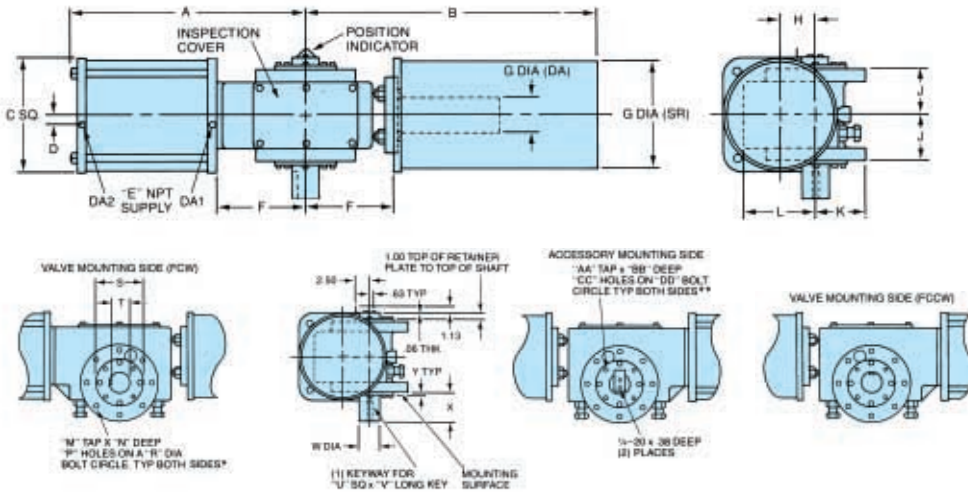

**Notes:**

1. All dimensions are in inches.
2. Pressure at port side DA1 will result in clockwise rotation, pressure at port DA2 will result in counter-clockwise rotation.
3. Orientation of accessory output may be indexed 90°.

\* AR2 Has only 4 holes at 45°  
 \*\*AR4 8 each 3/8 - 16x 3/4" deep holes on center line of "DD" diameter bolt circle are available for accessory mounting. The 3/8-16x 1" long hex head cap screws must be re-placed by a longer bolt equal to the thickness of the mounting bracket. The retainer plate is 1/2" thick.

\*\*AR2-AR3 A clearance hole for a 5/16" hex cap screw and lock-washer may be required to clear the retainer plate bolts on the center line of "DD" diameter bolt circle.

Model	A	B					C	D	E	F	G					H	J	K	L
		DA	SR40	SR60	SR80	SR100					DA	SR40	SR60	SR80	SR100				
AR205	19.82	17.01	29.00	30.00	32.00	33.00	5.75	1.19	1/4	7.19	2.00	9.13	9.13	9.13	9.13	3.00	3.25	2.78	5.75
AR206	19.82	17.01	30.00	30.00	32.00	38.00	6.75	1.19	1/4	7.19	2.00	9.13	9.13	9.13	9.13	3.00	3.25	2.78	5.75
AR207	19.82	17.01	30.00	32.00	38.00	40.00	7.75	1.19	1/4	7.19	2.00	9.13	9.13	9.13	9.13	3.00	3.25	2.78	5.75
AR208	19.82	17.01	33.00	38.00	40.00	41.00	8.75	1.19	1/4	7.19	2.00	9.13	9.13	9.13	9.13	3.00	3.25	2.78	5.75
AR310	23.00	18.13	34.00	36.00	39.00	42.00	10.75	0.00	3/8	8.19	3.50	13.25	13.25	13.25	13.25	3.00	4.13	4.44	6.81
AR312	23.00	18.13	36.00	38.00	41.00	43.00	12.75	0.00	3/8	8.19	3.50	13.25	13.25	13.25	13.25	3.00	4.13	4.44	6.81
AR314	23.50	18.13	39.00	41.00	44.00	45.00	14.75	0.00	1/2	8.19	3.50	13.25	13.25	13.25	14.63	3.00	4.13	4.44	6.81
AR316	23.75	18.13	42.00	44.00	45.00	N/A	16.88	0.00	1/2	8.19	3.50	13.25	13.25	14.63	N/A	3.00	4.13	4.44	6.81
AR414	30.87	25.37	50.00	56.00	59.00	55.00	14.75	0.00	1/2	11.56	4.50	14.63	14.63	14.63	16.63	4.50	5.82	6.50	9.75
AR416	31.12	25.37	57.00	59.00	55.00	56.00	16.88	0.00	1/2	11.56	4.50	14.63	14.63	16.63	16.63	4.50	5.82	6.50	9.75
AR418	31.69	25.37	59.00	56.00	57.00	59.00	20.88	0.00	3/4	11.56	4.50	16.63	16.63	16.63	16.63	4.50	5.82	6.50	9.75
AR420	31.94	25.37	59.00	56.00	57.00	59.00	20.88	0.00	3/4	11.56	4.50	16.63	16.63	16.63	16.63	4.50	5.82	6.50	9.75
AR422	32.12	25.37	55.00	58.00	59.00	N/A	23.75	0.00	3/4	11.56	4.50	16.63	16.63	16.63	N/A	4.50	5.82	6.50	9.75

Model	M	N	P	R	S	T	U	V	W	X	Y	AA	BB	CC	DD
AR2	5/8-11	1.00	4	5.750	4.25	1.718	.500	1.59	2.000	2.25	.31	1/4-20	.31	4	3.562
AR3	5/8-11	1.13	8	7.500	5.00	2.148	.625	3.50	2.500	4.25	.31	1/4-20	.31	4	4.375
AR4	7/8-9	1.13	8	11.000	8.00	3.261	.875	4.06	3.750	5.00	.50	3/8-16	**	8	7.187

### Volumes and Weights Double Acting & Spring Returns

Model Number	Volumes In <sup>3</sup>	Estimated Weights (lbs.)				
		DA	SR40	SR60	SR80	SR100
AR205	137	124	186	189	193	198
AR206	198	133	198	202	205	222
AR207	269	144	213	218	233	238
AR208	352	155	227	244	248	256
AR310	550	290	423	435	448	465
AR312	792	339	484	496	514	531
AR314	1078	401	560	576	593	665
AR316	1407	486	661	678	749	NA
AR414	1539	665	904	941	968	1127
AR416	2010	765	1039	1067	1226	1169
AR418	2544	901	1203	1362	1305	1423
AR420	3141	1038	1507	1443	1559	1578
AR422	3801	1347	1816	1869	1887	NA

## AR5 Dimensions

### AR5SR

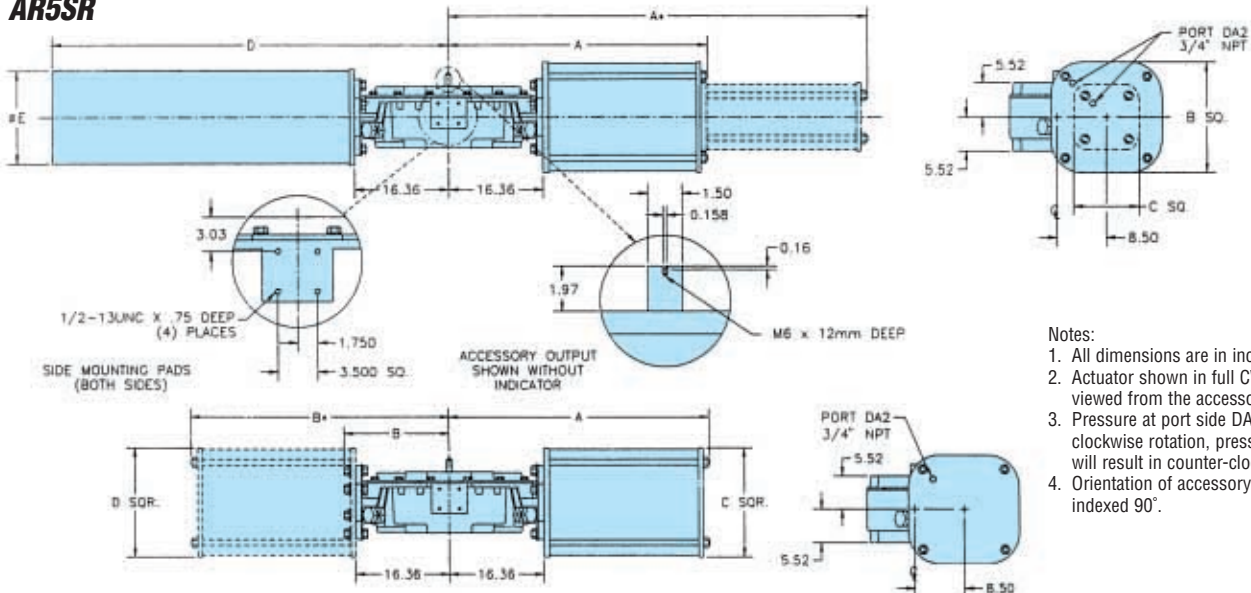

**Notes:**

1. All dimensions are in inches.
2. Actuator shown in full CW position, as viewed from the accessory side.
3. Pressure at port side DA1 will result in clockwise rotation, pressure at port DA2 will result in counter-clockwise rotation.
4. Orientation of accessory output may be indexed 90°.

### AR5DA

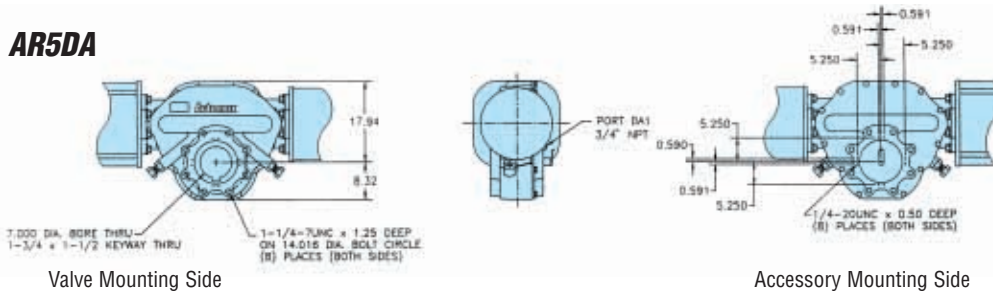

Valve Mounting Side

Accessory Mounting Side

Actuator	A	B	B*	C	D
AR514DA	44.17	17.46	N/A	14.75	N/A
AR51414DA	44.17	N/A	44.17	14.75	14.75
AR516DA	44.67	17.46	N/A	16.88	N/A
AR51614DA	44.67	N/A	44.17	16.88	14.75
AR51616DA	44.67	N/A	44.67	16.88	16.88
AR518DA	45.00	17.46	N/A	18.88	N/A
AR51816DA	45.00	N/A	44.67	18.88	16.88
AR51818DA	45.00	N/A	40.00	18.88	18.88
AR520DA	45.13	17.46	N/A	20.88	N/A
AR52020DA	45.13	N/A	45.13	20.88	20.88
AR522DA	45.50	17.46	N/A	23.13	N/A
AR524DA	46.00	17.46	N/A	25.50	N/A

Actuator Model	Volume (in <sup>3</sup> )	Weights (lb.)				
		DA	SR40	SR60	SR80	SR100
AR514	3233	932	N/A	N/A	N/A	N/A
AR51414	6466	1199	N/A	N/A	N/A	N/A
AR516	4222	1066	N/A	N/A	N/A	2040
AR51614	7455	1333	N/A	N/A	N/A	N/A
AR51616	8444	1467	N/A	N/A	N/A	N/A
AR518	5344	1180	1938	1992	2153	2260
AR51816	9566	1581	N/A	N/A	N/A	N/A
AR51818	10688	1695	N/A	N/A	N/A	N/A
AR520	6597	1297	2035	2253	2378	2559
AR52020	13194	1929	N/A	N/A	N/A	N/A
AR522	7983	1463	2276	2437	2725	2888
AR52214	11216	N/A	2704	2992	3274	3437
AR524	9500	1730	2686	2811	3155	3274
AR52416	13722	N/A	3212	3556	3838	N/A

Actuator	A	A*	B	C	D								E	
					40	60	80	100	125	150	175	200		
AR516SR	44.75	N/A	16.88	N/A	N/A	N/A	N/A	N/A	79.00	84.00	96.49	96.49	96.49	16.00
AR518SR	45.00	N/A	18.88	N/A	76.00	71.50	79.00	84.00	96.49	96.49	96.49	96.49	96.49	16.00
AR520SR	45.13	N/A	20.88	N/A	70.00	81.50	84.00	96.49	96.49	96.49	96.49	96.49	N/A	16.00
AR522SR	45.50	N/A	23.13	N/A	71.50	79.00	96.49	96.49	96.49	96.49	96.49	N/A	N/A	16.00
AR524SR	46.00	N/A	25.50	N/A	81.50	84.00	96.49	96.49	96.49	96.49	N/A	N/A	N/A	16.00
AR52214SR	45.50	71.88	23.13	14.75	79.00	96.49	96.49	96.49	96.9	N/A	N/A	N/A	N/A	16.00
AR52416SR	46.00	72.88	25.50	16.88	84.00	96.49	96.49	N/A	N/A	N/A	N/A	N/A	N/A	16.00

Insofar as possible, every effort has been made to ensure that the information contained herein was correct at the time of the printing. Products may differ as the result of the company policy of continuous product improvement.

**ACCORD**  
**CONTROLS**

765 South 100 East  
Provo, Utah 84606  
(801) 373-4576  
Fax (801) 489-2591

ACABROO4-00 04/02 © 2001, Flowsolve Corporation, Provo, Utah (AC-97)