

APEX NAMUR Shaft

APEX positioners are available with a NAMUR shaft option that enables direct attachment to actuator pinions without a coupler. This shaft features a 4 mm wide tang that engages the 4 mm slot in NAMUR actuators (see below). In addition, the shaft features a concentric hole which receives a 6mm pin threaded into the actuator pinion. This pin and hole arrangement permits precise alignment between positioner and actuator, reducing binding friction that can cause inaccurate valve positioning.

The APEX NAMUR shaft conforms to NAMUR standards for length. Automax offers standardized stainless steel NAMUR mounting kits that will adapt our positioners directly to actuators conforming to NAMUR standards for pinion height. This arrangement is one of the most cost effective, reliable and accurate mounting systems available.

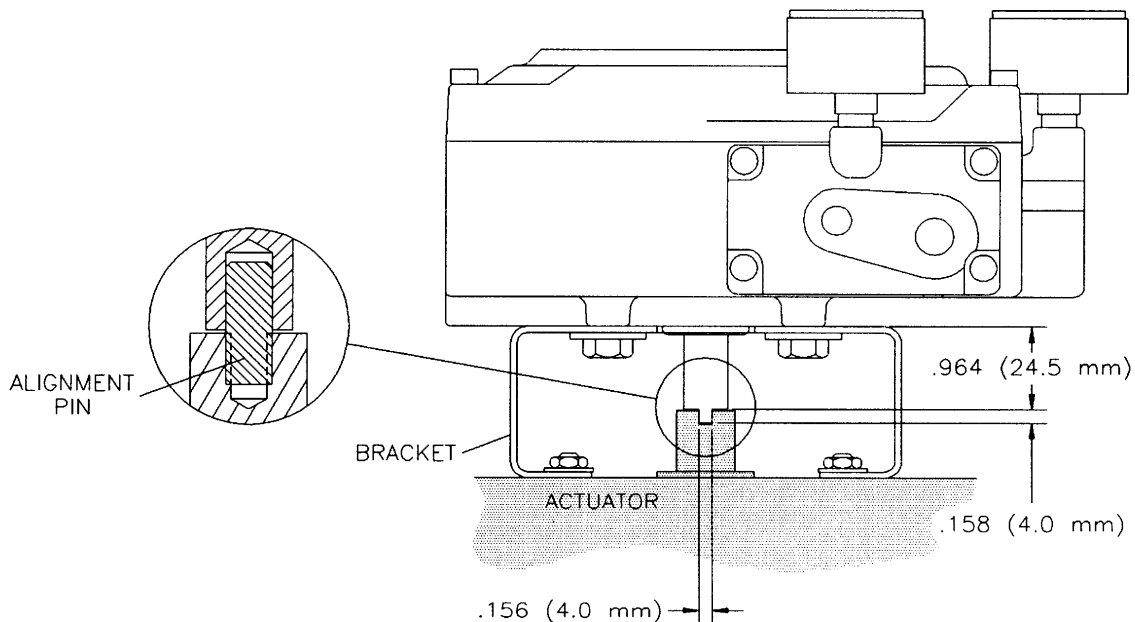

How to Order:

Referring to the table of contents page, simply specify a "T" for NAMUR shaft. To order a replacement shaft assembly, consult factory.