

Three-Position Control (Dribble Control)

Introduction:

The UltraSwitch™ Three-Position Control option is designed to operate an automated valve package through three distinct positions. It utilizes a unique cam assembly for precise mid-position calibration. Stopping near the end of travel for tank-topping dribble control or in the mid position for 3-way valve control is easily accomplished by adjusting the pinpoint accurate integral cams.



Applications:

Dribble Control is normally used with two-way valves that are required to operate at three different positions, such as tank filling applications. The valve is fully opened until the tank approaches full. The valve is then moved to the dribble position, which reduces flow and allows the tank to be "capped off" slowly. This feature reduces water hammer and minimizes spillage or over-filling.

The UltraSwitch™ Three-Position Control option may also be used to operate 3-way valves used in mixing or diverting applications.

Durable construction and corrosion resistant materials/coatings provide protection against the toughest applications in all process industries including:

1. Chemical and Petro-Chemical
2. Power
3. Food and Beverage
4. Pharmaceutical
5. Municipal and Wastewater Treatment

Features:

1. **Deadband Adjustment.** By loosening one screw and rotating the bottom cam, users can adjust deadband. This assures repeatable mid-position control from both open and closed directions without oscillation or overshoot through the setpoint.
2. **Midpoint Adjustment.** The cam assembly (both upper and lower cams simultaneously) can be infinitely adjusted by loosening two setscrews. Cam design permits pinpoint accuracy of switch tripping for precise control.

Accord Controls
A Unit of Flowserve Corporation
www.accord-controls.com

765 South 100 East
Provo, Utah 84606
Phone: 801 373 4576

1978 Foreman Dr.
Cookville, TN 38501
Phone: 931 432 4021

Principles of Operation:

The UltraSwitch™ Three-Position Control option may be used with any double acting or spring return actuator. Two solenoid valves are used with the UltraSwitch™ to control three positions for spring return actuators: one dual-coil, center-blocked, three-position solenoid valve is used to control three positions for double acting actuators. Consult the factory for wiring/piping diagrams to build complete valve assemblies for three position control.

Three signals are required. Each positive (DC coils) or high (AC coils) signal leg must be isolated to prevent backflow through the other legs during operation. This may be done with a multiple position selector switch (for manual operation), or with individual relays for PLC or DCS system interface where outputs are not electrically isolated.

To reach either extreme CW or CCW position, the two coils are energized or de-energized directly (independently for double acting or in combination).

To reach mid position, the signal is fed through switches to the appropriate coil. Upon reaching mid position both switches open, energizing or de-energizing that coil, locking the actuator in place (for spring return actuators, one coil remains energized and the other receives a signal through switches).

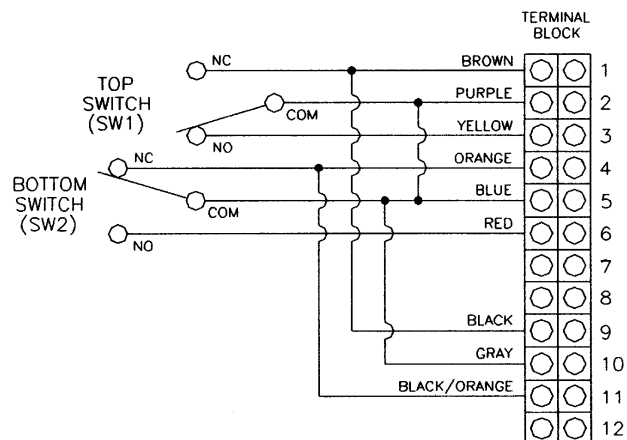
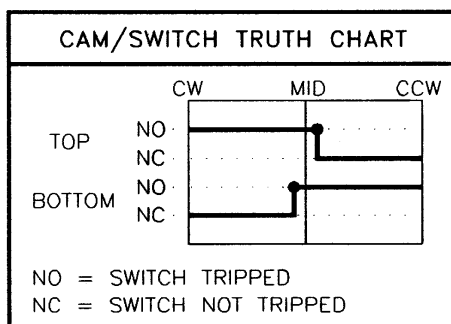

How to Order:

To order the Three Position Control option, simply specify "A" for the switch option in any UltraSwitch™ enclosure (example: AXL2A000 = UltraSwitch™ AXL explosion proof enclosure with Three Position Control option and two-way Pharos visual indicator). Unit also available with position indication. Consult factory. For three-way indicator options, see bulletin PS0040.