



11444 Deerfield Road  
Cincinnati, Ohio 45242  
(513) 489-7800  
FAX (513) 489-5243

# Lockout Module

## ISO Pattern

### Installation, Operating, and Maintenance Instructions

#### Installation Instructions

The Automax ISO pattern Lockout Modules (LOM) allow simple mechanical lockout of new and existing valve/actuator assemblies. Six models of the Lockout Module mount directly to any ISO pattern actuator with F05 through F16 patterns. The Lockout Module provides a compact mechanical lockout assembly which when properly implemented will satisfy OSHA Standard 1910.47, "The Control of Hazardous Energy". The Lockout Module mounts directly between a standard valve mounting kit and an ISO pattern actuator, requiring only a special coupler for the specific valve/actuator combination. This allows for easy field retrofit of a mechanical lockout device to

**Note:** The Automax Lockout Module is not suitable for valves requiring a constant positive shut-off torque to ensure sealing.

existing valve/actuator assemblies.



Lockout Module

Standard Mounting Kit

To install:

1. Note valve position, open or close. Move valve to desired lockout position. The actuator should be in a corresponding position.
2. Mount standard valve mounting kit to valve.
3. Install Lockout coupler to valve stem, properly orienting coupler for desired actuator position.
4. Position Lockout Module as desired on top of mounting kit. Insert lockout pin through lockout coupler to properly orient the lockout module. Tighten bolts until snug.

5. Place actuator onto lockout module. Tighten bolts until snug.
6. Stroke actuator several times to properly align coupler. If necessary, adjust actuator travel stops at this time.
7. Return valve to desired lockout position. Insert lockout pin through lockout coupler to ensure proper alignment. If necessary, loosen bracket/LOM bolts and rotate LOM to align lockout coupler with LOM slots to allow pin insertion. Tighten all mounting hardware.

**Note:** When locking out a high-performance butterfly valve, or other valves with "quick opening" characteristics, bias the lockout module housing against the lockout pin. To lockout a HPBV in the closed position, rotate housing clockwise against pin to keep valve from opening counter clockwise.

8. Remove lockout pin from coupler and insert into storage brackets in the side of the LOM housing.
9. Stroke actuator several times to ensure mounting bolts are tight enough. Lockout module should not slip in actuator or bracket.

#### Operation

The Lockout pin may be stored and locked in the storage brackets provided on the Lockout housing. To lock out a valve, position valve in desired setting. The hole in the Lockout coupler should align with the slots in the Lockout housing. Insert the Lockout pin through the hole in the Lockout coupler, and apply a

**Warning:** Do not stick foreign objects, such as fingers, screwdrivers etc. into Lockout hole. Serious injury may result. Use only Lockout pin supplied with Lockout Module to lock out actuator.

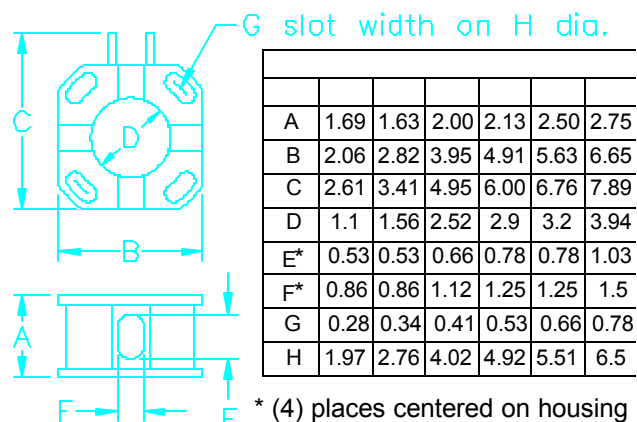



11444 Deerfield Road  
Cincinnati, Ohio 45242  
(513) 489-7800  
FAX (513) 489-5243

# Lockout Module

## ISO Pattern

lock to end of the pin extending from the other side of the Lockout housing.

## How To Specify

### Maintenance Instructions

No periodic maintenance is necessary for the Lockout Module. All parts are designed for the full rated load of the ISO valve pattern capable of being mounted to a given Lockout Module. All materials of construction are corrosion resistant, including an aluminum powder coated epoxy housing.

The lockout device shall be an Automax Lockout Module, capable of being sandwich mounted between an actuator and a standard mounting kit. It shall be capable of adjustment in one position, and rated for the full load torque of the valve pattern specified. The housing shall be electrostatic powder coated epoxy aluminum, and the Lockout pin shall be tethered to the Lockout housing and capable of being safely secured on the unit, when not in use. All materials of construction shall be corrosion resistant.

### Options

Single position

Lockout housing is supplied with only one set of operable lockout slots. Housing may be oriented to provide either lockout open or lockout close.

Stainless steel housing / pins

### How To Order

Lockout Module	Single/Dual Position	Size (ISO)	Options
LOM	Blank -Dual Position S1 -Single Position	F05 F07 F10 F12 F14 F16	SS -Stainless Steel Housing / Pin SP -Stainless Steel Pin

Example: To order dual position Lockout Module stainless steel for ISO F10 pattern, order LOMF10SH

Note: When ordering Lockout mounting kits or Lockout couplers, specify actuator size and model, and valve size.

Example: To retrofit existing SX125 mounted to a 3" Durco plug valve, LOMF10 with Lockout Coupler for SX125 to 3" Durco G411.

Studs, bolts, and washers are stainless steel.  
Stainless Housing/Pin

### Bill of Materials

Item	Description	Material	Qty.
1	Lockout Module housing	Aluminum epoxy powdercoat	1
2	Lockout coupler	Steel/epoxy powdercoat	1
3	Lockout pin	Steel/zinc plate	1
4	Lockout pin cable	Steel/nylon coat	1

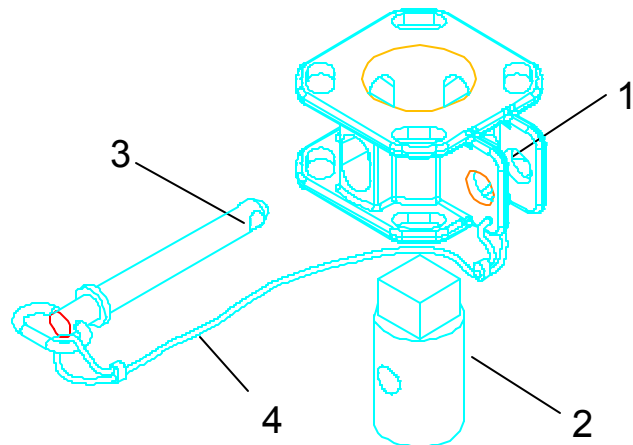

11444 Deerfield Road  
Cincinnati, Ohio 45242  
(513) 489-7800  
Fax (513) 489-5243

**Automax Controls, Inc.**  
120 Vinyl Court  
Woodbridge, Ontario L4L-4A3  
(905) 856-8568  
Fax (905) 856-7905

**Davco Equipment**  
1744 W. 4th St. Suite208  
Freeport, TX 77541  
(409) 239-3300  
Fax (409) 239-2311