

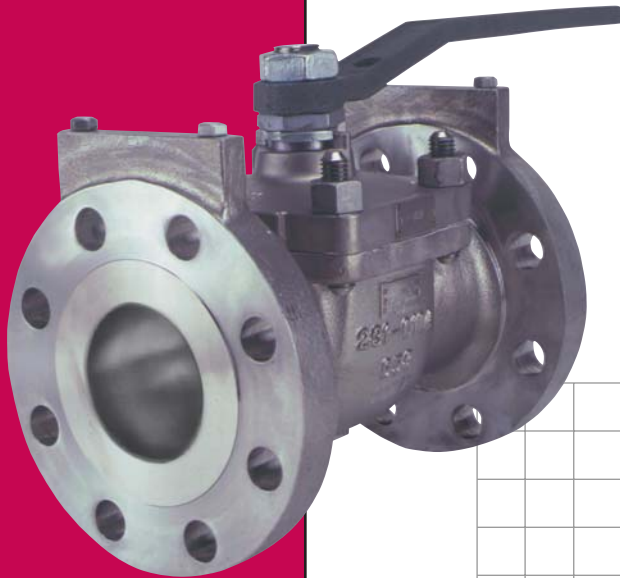

McCANNA Valves

RFP 100-2



An ISO 9001 Registered Company

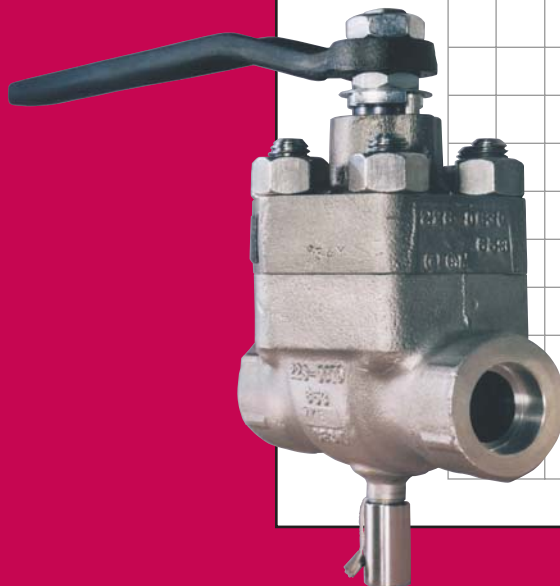
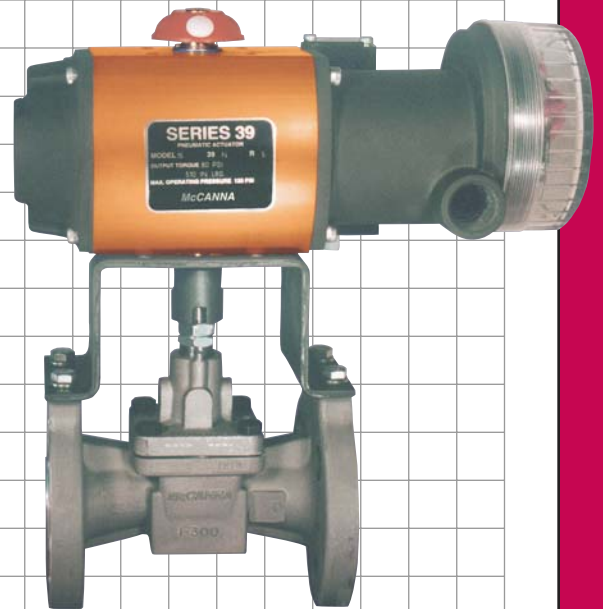

McCannaseal[®]
Top Entry Wedge-Seated Ball Valves
Regular and Full Port

Table of Contents

McCannaseal Ball Valves

- Design Features3
- Body Variations and Materials4
- Seat Materials5
- Bonnet Configurations6
- Application and Special Services7
- Options9
- Fire-Seal®/High-Temperature Service/Ball Stops10
- Low Temperature11
- Pressure/Temperature Ratings12
- Performance Data14
- Dimensions and Weights15
- Materials of Construction19
- Automated McCannaseal Valve Packages21
- How to Specify and Order23

Industry Standards

McCannaseal Ball Valves meet the following valve industry standards, within temperature ratings published on pages 12 and 13 of this brochure: ANSI B16.34, B16.5, B16.10, B16.11, B16.25 and B2.1.

Design Features

The McCannaseal is the original patented top entry wedge seated ball valve. Available in regular port sizes from 1/2" through 20" and pressure classes from 150 to 1500, and in full port sizes ranging from 1" through 16" class 150 to 1500, the McCannaseal has proven itself successful in over 43 years of severe service applications. The McCannaseal reputation for consistent, reliable operation in handling today's most volatile applications is known the world over and is featured in various approved manufacturer's lists for all types of processes.



1. **Top Entry** for fast, easy, in-line service that simplifies scheduled maintenance and permits emergency entry in minutes just by removing the bonnet. All working parts are accessible for service while the valve body stays fixed in the line. No special tools or training are required.
2. **Wedge-Seat Design** permits use of a wide range of seat materials. The ball and seats are self-adjusting, assuring leak-tight closure under all operating conditions and valve orientations. Seats are kept in tight contact with the ball to assure an even, non-binding, elastic load on the seats at all pressures, temperatures and at all stages of seat wear. Consequently, positive leak-tight shut-off is assured for the full life of the seats. Seats are under compression load only and there is no flexing or bending of the seat material.
3. **Available in a Wide Range of Body and Trim Materials.** Body and trim materials include Carbon Steel, Stainless Steel, Titanium, Nickel, Monel*, Hastelloy* "B" and "C", Alloy 20 and others. Almost any fluid can be handled including liquids, gases, slurries, semisolids, viscous substances and some molten materials.
4. **Seat Range.** McCANNA offers a wide variety of seats, ranging from soft seats (plastics) to full ceramic. This allows the McCannaseal to handle temperatures from -320°F to 1500°F and beyond.
5. **Ball is Wiped Clean Each Time the Valve is Operated.** Ball-seat contact is constantly maintained, extending seat life.
6. **Backseated Stem-Conical Stem Seals.** The stem shoulder design eliminates any possibility of stem blowout. The double set of stem seals are designed so that increased line pressure will increase stem sealing.
7. **Bi-Directional Flow Capability** for tight closure in either flow direction.
8. **Quarter-Turn and Low Torque** make McCannaseal ball valves particularly suitable for remote operations with pneumatic or electric actuators, especially when high cycle frequency is required.

* Various trademarks

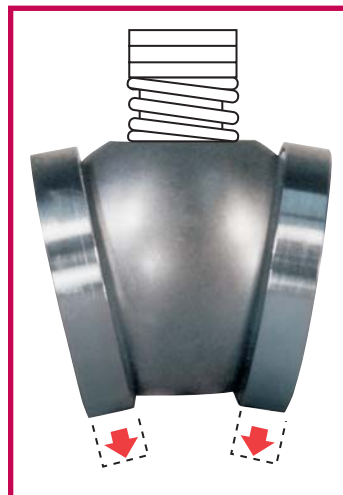

Body Variations and Materials

Body Variations



Flanged

Raised face.
(125-250 Micro-Inches Ra).

Flat faced.

Ring type joint.

Large or small tongue and groove per
ANSI B16.5.

Boss flanges for actuator mounting standard on
regular port sizes 3/4" – 6" up to 600 Class, and
full port 1" – 4" up to 600 Class.



Threaded and Socket End

Threaded per ASME B1.20.1.
Socket Weld per ANSI B16.11.



Butt Weld End

Per ANSI B16.25.
Various schedules available.

Body Materials

AL — Aluminum	NI — Nickel
A2 — Alloy 20	N8 — Incoloy 800
BR — Bronze	S4 — Stainless Steel 304
CS — Carbon Steel	4L — Stainless Steel 304L
C3 — LCB	6L — Stainless Steel 316L
DS — Duplex S.S.	S6 — Stainless Steel 316
HB — Hastelloy "B"	TI — Titanium
HC — Hastelloy "C"	9L — Stainless Steel 904L
IN — Inconel	N9 — Incoloy 825
MO — Monel	

Trim Materials

AL — Aluminum
A2 — Alloy 20
BR — Bronze
HB — Hastelloy "B"
HC — Hastelloy "C"
IN — Inconel
MO — Monel
NI — Nickel
4L — Stainless Steel 304L

...plus many special body and trim materials.

Refer to the "Material Selection Guide" in the "McCANNA Flow Manual for Quarter-Turn Valves" for information on material compatibility.

Seat Materials

T – TFE Unfilled polytetrafluoroethylene. Molded fluorocarbon plastic having low coefficient of friction and unique anti-stick properties. Material has a waxy texture and is opaque with a milk-white color. TFE is non-contaminating and accepted by FDA for use in food services. The material is highly resistant to oxidation and the effect of most chemical agents and gases. Although resistant to most organic hydrocarbons, unfilled TFE is not recommended for use in halogenated solvents or permeative media (vinyl chloride, styrene).

U – Reinforced TFE (Fire-Seal design) (nonpigmented) Qualified to API-607 4th edition, TFE resin compounded with a selected percentage of glass filler material to provide improved strength and resistance to abrasive wear, cold flow, and permeation in the finished molded seat. Reinforcement permits application at higher pressure and temperature than unfilled TFE. Not recommended for applications known to attack glass (hydrofluoric acid, hot, strong caustics typical).

R – Reinforced TFE Same material as U seat, except **non-fire-seal design**. R seats are pigmented red for identification.

W – HiLoad TFE (Fire-Seal design) Filled TFE qualified to API-607 fire test. TFE resin compounded with a special carbon reinforcing material to provide exceptional resistance to load deformation, abrasion, and fluid penetration. The finished properties permit application at higher pressures and temperatures than the R or U seats, including use in saturated steam and many chemical solvents up to 400°F (204°C). Maximum temperature is 550°F (288°C). The W seat will generally be applied in difficult higher temperature services that may be flammable, hazardous, or mildly abrasive. The resistance to fluid penetration provided by the “barrier” characteristics of the filler in the molded structure will provide longer service life than possible with the general purpose reinforced material. The W material is black in color.

G – Carbon graphite manufactured by blending carbon and/or graphite powders with a binder, pressing the mass into a desired shape, and baking the molded form at high temperatures. The resultant hard seat material is highly wear and abrasion resistant, nearly chemically inert, and thermally stable. G seats are generally intended for valve service conditions ranging from 550°F (228°C) up to 1000°F (538°C) maximum in non-oxidizing service fluids and gases. Application in oxidizing media (nitric acid, chromic acid, sulfuric acid, chlorine, peroxides, nitrates, nitrites, chlorates, perchlorates, permanganates, ozone, oxygen, and air, typical) is limited to 700°F (371°C). G seats are excellent in high-pressure saturated steam service — maximum 300 psig (20.4 bar) @ 422°F (217°C) — and superheated steam to a maximum of 700 psig (47.6 bar) @ 750°F (399°C). (-400°F on the low end.)

J – PEEK Carbon reinforced polyetheretherketone. This black seat material has excellent wear properties in high cycle long term services. Pressure capability is 1275 psig (85 bar) at 360°F (182°C), and maximum temperature is 600°F (316°C). Recommended applications include saturated steam and non-sticking polymer service as well as radiation service. Conditions to avoid include food service where the black color might be a contamination problem, concentrated sulfuric (H₂SO₃), and concentrated nitric (HNO₃) acids.

M – Metal seats are intended for use under extreme service conditions falling outside the limitations of resilient seating materials, and above the G seat 700°F (371°C) limit in oxidizing media. They are strongly recommended for highly abrasive media and for temperatures to 1000°F (538°C), and may be applied in saturated steam to 700 psig (47.6 bar) at 502°F (261°C).

Waukesha 88* Non-galling high nickel content alloy. Maximum temperature rating 1000°F (538°C). Recommended for services that are both corrosive and abrasive and in oxidizing media above 700°F (371°C). Also used in abrasive services in the G seat range where entry of black particulate into the product stream cannot be tolerated.

Stellite* Cobalt-chromium-tungsten alloy recognized for resistance to wire drawing, erosion and galling, and retention of hardness at high temperatures. Corrosion resistance approximates that of 18-8 stainless steel. Stellite seats are normally recommended for the most abrasive service media (catalyst fines, mine slurries typical), to 1500°F (816°C).

L – CeraMc has high hardness for erosion/abrasion resistance, inertness for chemical resistance, and the ability to withstand extremely high temperatures to 1500°F (816°C). A unique process produces a new “Toughened” ceramic material that is stronger and more durable than the alloys and metal composites previously available.

Also available:

D – Double block and bleed C – FEP
K – Kel-F* Z – Tefzel*
P – UHMW Polyethylene 3 – ZYMAXX*
V – Polyimide

See pages 12 and 13 for Pressure/Temperature Ratings.

Note: Other special materials are available for your critical applications. For your specific application recommendation contact Flowserve.

Standard Seal Materials** (Stem, Bonnet, Ball Stops)

For Seats:	Standard Seal
T	TFE
R	RTFE
U, W, G, M, L, J, 3	Flexible Graphite†

* Various trademarks

** Application information or customer request can change selection as appropriate.

† Spiral wound bonnet gasket available.

Bonnet Configurations

Bonnets

McCannaseal valves are available in a wide variety of bonnet configurations. In addition to standard bonnets, McCannaseal valves are offered with extended bonnets for high-temperature, semi-cryogenic and cryogenic applications.

Extended Bonnets

Extended bonnets for McCannaseal ball valves are available in sizes from 1/2" through 8".

The extended bonnet supports potential side loads thereby reducing the possibility of stem galling and leakage under severe services.

Insulation can be securely packed up to the top of the bonnet with little danger of undetected stem leakage.

The McCannaseal extended bonnet assembly is interchangeable with standard McCannaseal bonnet assemblies.

Configurations:

DAE – Improves stem seal performance by raising the seal arrangement out of the proximity of the fluid flow, thus maintaining seals at a more normal temperature. Recommended for clean services. Special preparation designation DAE.

DAB – One set of stem seals located at the lower end of the stem journal in place of the guide bushing used in type DAE. Recommended where line fluid may solidify upon cooling or where fluids contain fine solids. Special preparation designation DAB.

FAB – Equipped with a leak detection port between two sets of packing. Should the lower packing fail, a leak would be detected before it escapes into the atmosphere.

The intermediate packing area can also be pressurized in some applications to ensure one direction emission flow into the process with a benign medium. Special preparation designation FAB. For more information refer to brochure for Fugitive Emissions, FETR-1.

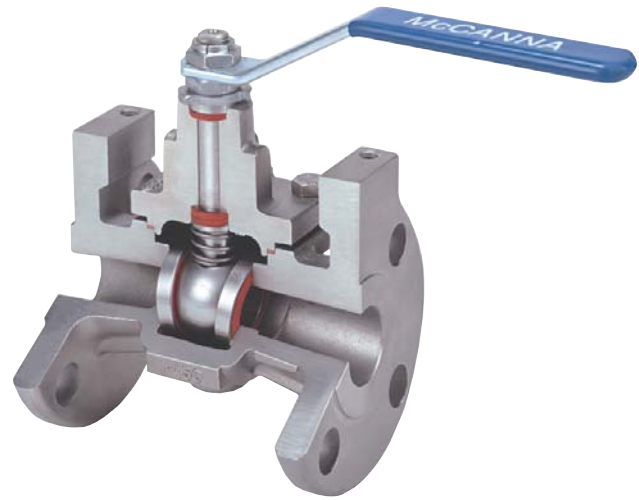

Regular Port Valve Size in/mm	Full Port Valve Size in/mm	Amount of Extension Above Standard	Max. Insulation Thickness
1/2, 3/4, & 1 15, 20 & 25	— —	1.75 31.8	1.5 38.1
1 1/2 40	1 25	1.5 38.1	2.00 50.8
2 50	1 1/2 40	1.75 44.4	2.5 63.5
3 80	2 50	2.00 50.8	2.75 69.9
4 100	3 80	2.00 50.8	3.5 88.9
6 150	4 150	2.00 50.8	4.00 101.6
8 200	6 150	2.00 50.8	4.75 120.7

Note: The DAB extended bonnet configuration is standard on all sizes of ANSI Class 600, 900 and 1500 valves.

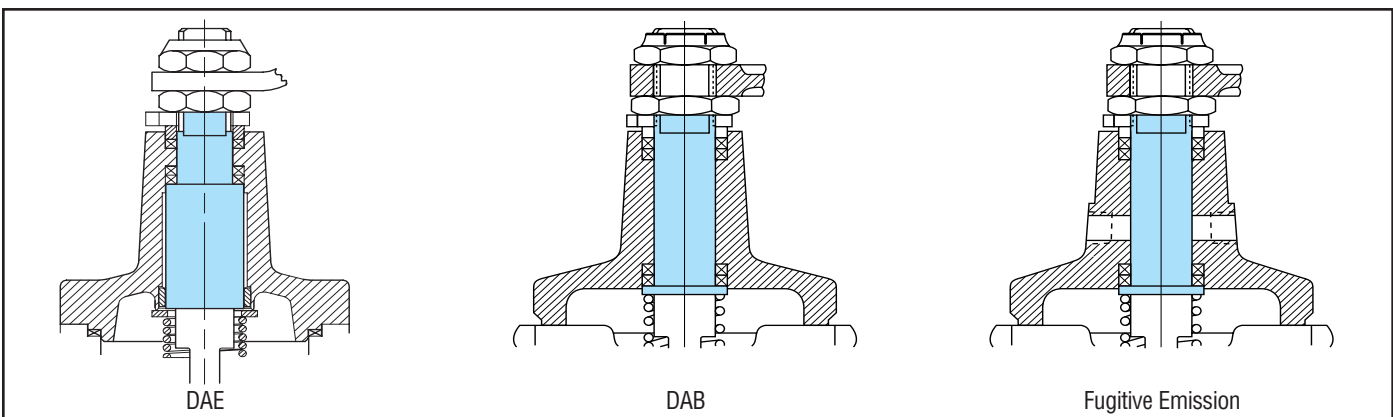

Application and Special Services

McCannaseal ball valves are manufactured in a broad range of materials to handle nearly any service. Corrosive chemicals, viscous liquids, gases, acids, alkalies, and hydrocarbons are easily controlled. In addition, specifically fabricated McCannaseal valves are available for special services including:

Chlorine – The McCannaseal ball valve meets all recommendations listed in the Chlorine Institute Pamphlet Number 6 “**Piping and Equipment For Use With Dry Chlorine.**” This top entry valve can be supplied specially prepared and tested with any combination of materials as specified by the Chlorine Institute. For further information refer to McCANNA Product Data Bulletin PDB-5.

Hydrogen Peroxide – Basic recommendation is a one-way valve if compatible with the system. If not compatible, a special self-relieving seat design prevents trapped hydrogen peroxide from building up pressure in the body cavity. For further information refer to McCANNA Product Data Bulletin PDB-22.

PTA – McCannaseal top entry ball valves are readily available in the appropriate sizes, materials, pressure and temperature specifications to meet any PTA service condition. For further information refer to McCANNA brochure PTA-01.

Vacuum – McCannaseal valves can be specially prepared for vacuum service and are suitable for high vacuum to 1 x 10⁻⁶ mm Hg. If required, certified mass spectrometer test can be supplied. For further information refer to McCANNA Product Data Bulletin PDB-3.

Oxygen – McCannaseal valves for gaseous oxygen service are specially cleaned, assembled, and tested to ensure removal of all burrs, dirt, hydrocarbon grease, and other contaminants. Valves are individually wrapped and sealed in polyethylene bags before shipment. For further information refer to McCANNA Product Data Bulletin PDB-15.

LPG – Underwriters Laboratories Inc. has listed certain McCannaseal ball valves for use in applications handling Liquefied Petroleum Gas. For further information refer to McCANNA Product Data Bulletin PDB-9.



Fire Protection – Underwriters Laboratories Inc. has listed certain McCannaseal ball valves for use in Fire Protection Systems. These valves are listed under U.L. Guide No. VQGU for installation in water lines for sprinkler system, fire hoses, and other applications concerned with fire protection. The following McCannaseal valves are included: 3/4" through 3", threaded ends; 3/4" through 4", ANSI Class 150 flanged ends; bronze (1/2" – 3"), carbon steel, SS316 body and trim materials; TFE bonnet gasket; TFE seats and seals.

Steam – The design principle of the McCannaseal valve lends itself to applications in steam service of much higher pressures than other ball valve designs. For further information refer to McCANNA Product Data Bulletin PDB-6.

Block and Bleed – ANSI Class 150 and 300 McCannaseal valves can be furnished with double block and bleed seat designs. Positive tight closure in both directions simultaneously is possible, preventing product contamination in a pipe manifold arrangement. For further information refer to McCANNA Product Data Bulletin PDB-4.

Application and Special Services

Throttling – McCannaseal ball valves with electric or pneumatic actuators and positioners provide throttling control for liquids and gases. Ball valves provide tight shutoff unlike some other types of control valves. The ball valve is approximately equal percentage (flow characteristic curve), which makes it ideally suited for control applications in the 10% to 90% range.



Thermal Fluid Service – Extended bonnets permit the valve to be insulated with no contact between the insulation and the moving stem. Longer packing life results as the critical rings operate at a lower temperature. An accessible packing nut provides for visual leak detection and easy adjustment. McCannaseal's wedge design permits the use of high temperature rigid seats that are field-maintainable and cost-effective.



Other

- | | |
|-------------------|--------------------------------|
| TDI | Catalyst Slurry |
| VCM | Nitric Acid |
| TiO ₂ | Pet |
| Phosgene | Caustic (NOAH) |
| HF Acid | H ₂ SO ₄ |
| Hydrogen Peroxide | Ammonia |
| Ethylene Oxide | HCL |
| Poly Ethelene | |

Options



Gear Actuators

Gear actuators are available for manual operation tailored to the torque characteristics of the valve selected. Chainwheels and locking devices are optional.



Locking Handles

A locking device provides ability to lock open or lock closed.

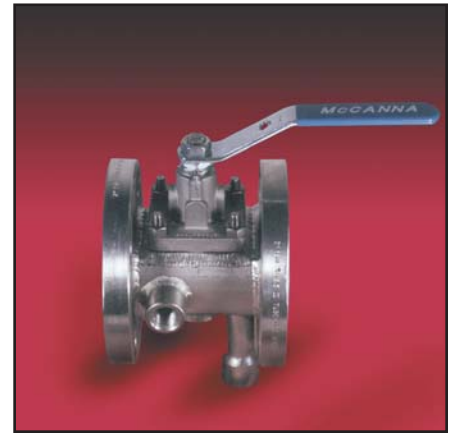

Jacketed Valves

Jacketed valves for viscous or solidifying services which must be kept heated for free flow are available. The addition of a high-temperature bonnet and carbon graphite or metal seats enable a jacketed McCannaseal valve to handle an ever widening range of difficult service. Full fabricated jackets (oversize flanged); partial body jackets or clamp-on type jackets can be supplied to suit system requirements.



Power Actuators

McCannaseal valves are ideally suited for remote actuation. See page 20 for actuator recommendations.



Stem Extensions

For manual or automated operation in hard to reach locations. Stem extensions are available 1/2" through 4" in half-inch increments for all sizes and classes of valves.



Chain Handle Operation

For actuation below valve installation.

Fire-Seal® / High-Temperature Service / Ball Stops

Fire-Seal® Seats

McCannaseal Valves with Fire-Seal seats are tested and approved to meet API-607, 4th edition and Exxon fire testing standards. The Fire-Seal design consists of a metal retainer enclosing a TFE or RTFE seat. Should the soft seat be destroyed by fire, a secondary metal seat provides a backup. The non-cycling, compression-loaded spring provides a mechanical advantage to ensure a tight ball-to-seat and seat-to-body seal with either resilient or metal seating elements. Flexible graphite stem seals and bonnet gaskets are standard in valves with Fire-Seal seats.

Ball Stops

McCannaseal valves supplied with non-resilient (carbon-graphite, metal, or ceramic) seat materials require additional considerations because of service applications. The coefficient of friction of these materials is greater than that of TFE or RTFE seats, and valves supplied with carbon-graphite, metal, or ceramic seats will have higher operating torque. Some applications for valves with these non-resilient seats will tend to increase the valve operating torque more than can be tolerated. Examples of such applications are high temperatures with large variations in temperature; fluids or gases containing solids; solidifying services (such as molten metals); and services which cause formation of deposits on ball or seat surfaces.

An adjustable ball stop is provided for use with non-resilient seat materials. The ball stop permits the valve ball and seats to be positioned to provide proper closure, but additional movement downward in the “wedge” is limited, and increases in operating torque in the services described above are controlled. The ball stop adjustment is set at the factory for optimum performance, and is field adjustable to compensate for ball and seat wear or changes in operating conditions.

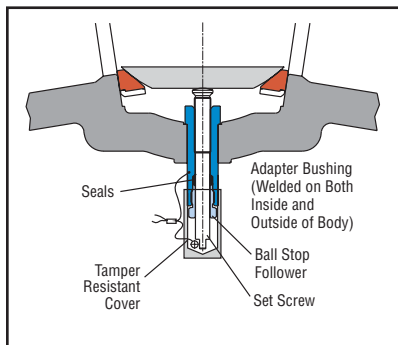

All McCannaseal valves with metal or ceramic seats are supplied with ball stops. Valves with carbon-graphite seats operating at temperatures above 500°F must be supplied with ball stops. Carbon-graphite seated valves operating at temperatures below 500°F may require ball stops where other service conditions can cause high operating torque.



High Temperature Service

The McCannaseal ball valve is a spring-loaded, self-adjusting, wedge-seated design. The seats are under compression load only, and not dependent on flexure or bending to ensure positive shutoff, as are most other ball valve designs. This design permits the use of non-resilient materials such as carbon graphite, metals, or ceramics as seat materials, for services at temperatures well beyond the capabilities of resilient seat materials.

Carbon-graphite seats may be used in services at temperatures up to 1000°F (538°C), and are unaffected by most chemical reagents. Exceptions to this are highly oxidizing materials, in which cases the maximum operating temperature must be limited to 700°F (371°C). Carbon-graphite seats have inherent lubricating properties, which result in operating torques lower than would normally be expected from a non-resilient material.

Where highly oxidizing conditions exist, or where the service is highly erosive or abrasive, the McCannaseal valve is available with metal seats, either Waukesha 88 or Stellite*. Waukesha 88 alloy is highly resistant to galling and seizing, and is recommended in oxidizing services above the carbon-graphite seat limit, or for corrosive or abrasive services to temperatures of 1000°F. Stellite balls and seats are normally specified for the most highly abrasive services. Stellite resists wire drawing, erosion and galling, as well as corrosion from a wide range of acids, alkalis, and molten metals, and retains its hardness to 1500°F. Ceramic balls and seats are recommended in severely corrosive services, and can also handle temperatures up to 1500°F.

Extended bonnets with flexible graphite stem seals and bonnet gaskets should be used for valves in services where temperatures will exceed 600°F.

* Registered trademark of Stoodly Deloro Stellite, Inc.

Low Temperature

McCannaseal Cryoseal®

For semi-cryogenic temperatures (-130°F (-89°C) to +32°F (+0°C)), (-40°F at stem seals) the type DAE extended bonnet with reinforced TFE stem seals and seats may be used under favorable conditions.

Cryogenic temperatures to -320°F (-196°C) require special Cryoseal bonnets.

The Cryoseal bonnets have a specially extended stem which positions stem seals in a warmer area above the colder medium. This insulates the seal area from colder liquid, and prevents formation of "ice cake" on the stem.

If liquid cryogen becomes trapped in the valve body cavity when the valve is closed, pressure buildup from the warming liquid is relieved through a small hole immediately above and behind the upstream body seating surface. As pressure builds, the fluid is vented back into the upstream line.

Stems are double-sealed and back-seated. Consequently, the higher the line pressure, the tighter the stem seal will be. This limits external leakage if the stem is accidentally loosened while the valve is still under pressure.

Cryoseal/ANSI Class 300/Threaded and Socket Weld Ends/Series C302 & C303

Size in/mm	A ¹	A ²	D	R
¾ 20	3.81 96.8	3.69 93.7	11.75 298.5	.81 20.6
1 25	3.81 96.8	3.69 93.7	11.75 298.5	.81 20.6
1½ 40	4.88 124.0	4.75 120.7	12.81 325.4	1.19 30.2
2 50	5.63 143.0	5.50 139.7	14.19 360.4	1.50 38.1
3 80	9.19 208.0	8.00 203.2	16.31 414.3	2.25 57.2

A¹ Threaded

A² Socket

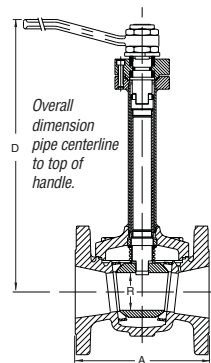

Cryoseal Construction

Part Description	Stainless Steel
Body—Threaded or flanged ends	ASTM A351 CF 8M
Body—Socket or butt weld ends	ASTM A351 CF 3M
Bonnet	ASTM A351 CF 8M
Upper Flange	ASTM A276 Type 304
Extension Tubing Flange	ASTM A276 Type 304
Extension Tube	ASTM A312 TP 304
Stem Extension	ASTM A276 Type 316
Ball*	ASTM A276 ■ Type 316 ASTM A351 ■ CF 8M
Stem	ASTM A276 ● Type 316 Cond. "B"
Spring	Inconel X750
Seat Ring	Aluminum** ASTM B210 Alloy 6061-T6
Capscrew	SS 18-8

* Size of valve determines ASTM specifications. Consult factory for specific information.

■ Hard chrome plated

● Crack-free chrome plated

** Stainless steel also available, please specify.

Cryoseal/ANSI Class 150 & 300/Flanged Ends/Series C151 & C301

ANSI CLASS 150

Size in/mm	A	D	R
¾ 20	4.88 117.5	11.75 298.5	.81 20.6
1 25	5.00 127.0	11.75 298.5	.81 20.6
1½ 40	6.50 165.1	12.81 325.4	1.19 30.2
2 50	7.00 177.8	14.19 360.4	1.50 38.1
3 80	8.00 203.2	17.75 450.9	2.25 57.2
4 100	9.00 228.6	18.06 458.7	3.00 76.2
6 150	15.50 393.7	20.94 531.9	4.50 114.3

ANSI CLASS 300

Size in/mm	A	D	R
¾ 20	6.00 152.4	11.81 300.0	.81 20.6
1 25	6.50 165.1	11.81 300.0	.81 20.6
1½ 40	7.50 190.5	12.88 327.2	1.19 30.2
2 50	8.50 215.9	14.50 368.3	1.50 38.1
3 80	11.12 282.4	17.75 450.9	2.25 57.2
4 100	12.00 304.8	18.06 458.7	3.00 76.2
6 150	15.88 403.4	20.94 531.9	4.50 114.3

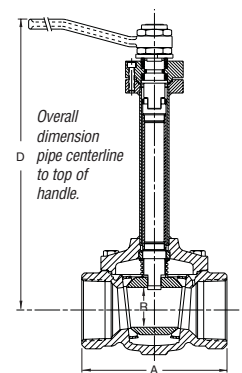

NOTE: For Full Port Valves Consult Factory.

Pressure/Temperature Ratings

POLYMERIC/FIRESEAL SEATS

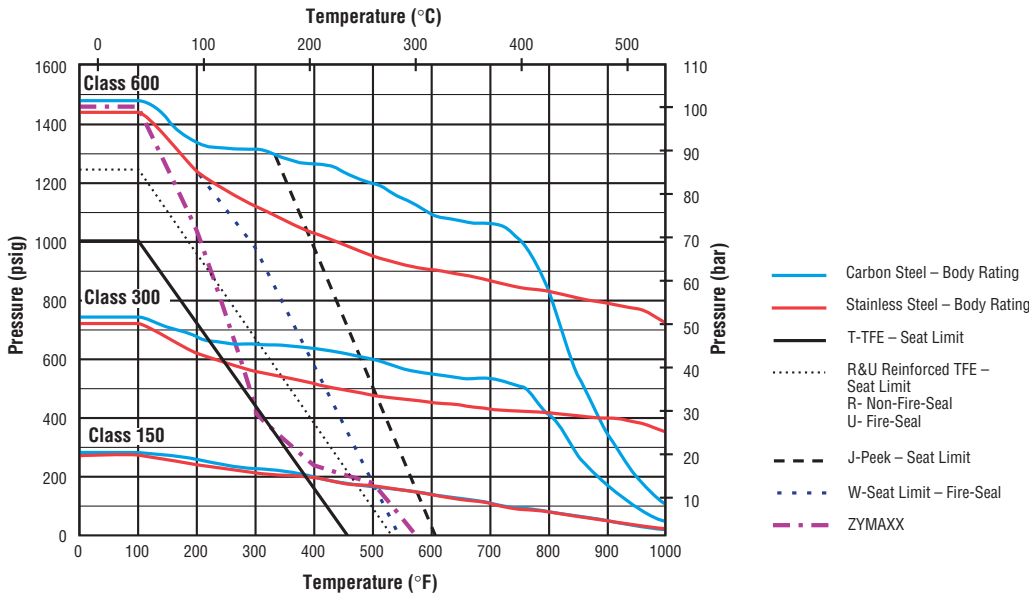

CARBON GRAPHITE, METAL & CERAMIC SEATS

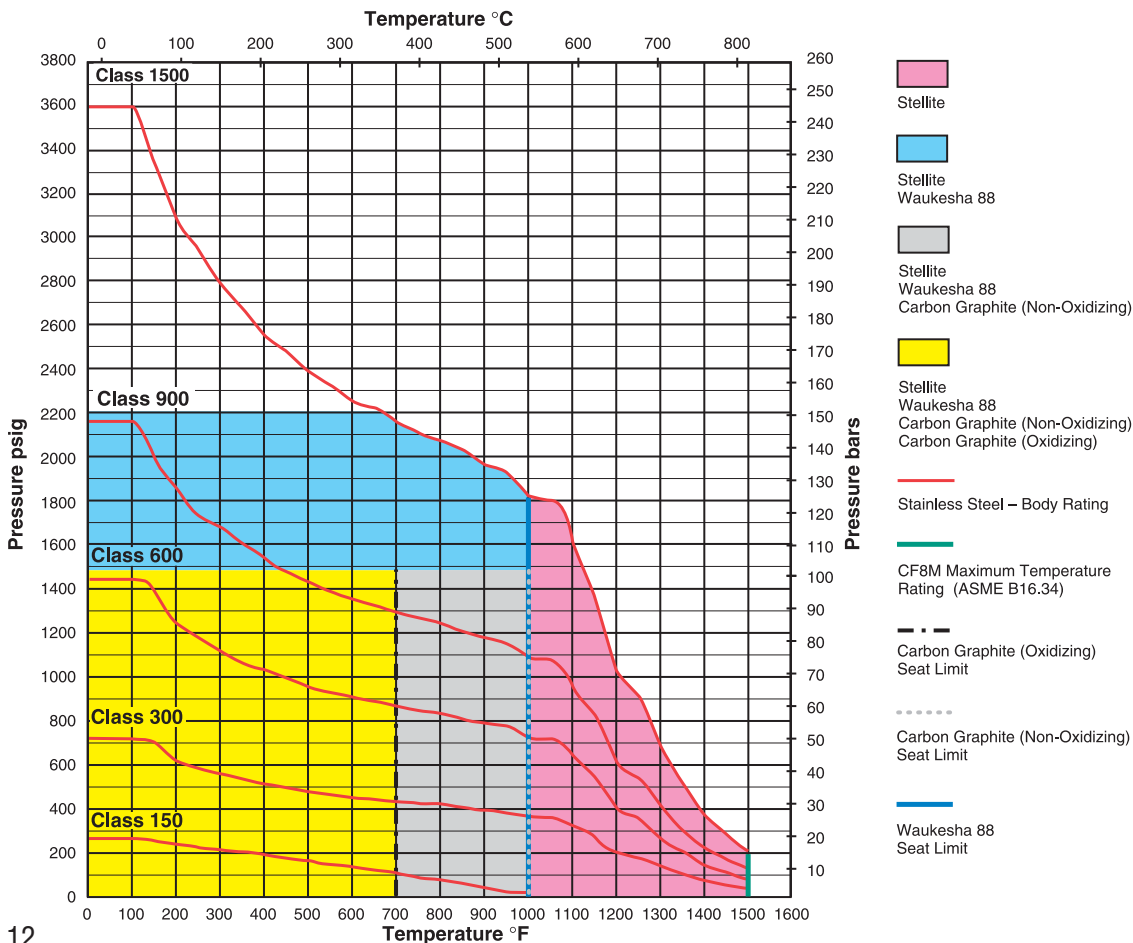

Pressure/Temperature Ratings (continued)

TITANIUM BODIES

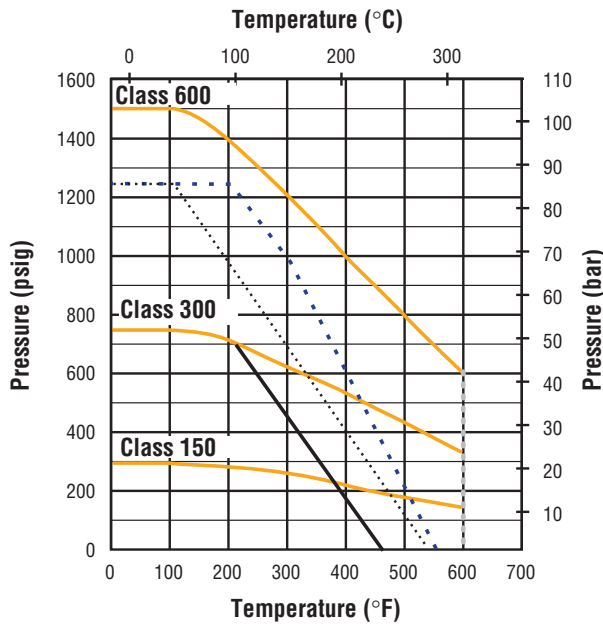

- Titanium – Body Rating
- T-TFE – Seat Limit – Fire-Seal
- R&U Reinforced TFE – Seat Limit – Fire-Seal
- W-Seat Limit – Fire-Seal
- Carbon Graphite (Non-Oxidizing)

BRONZE AND ALUMINUM BODIES

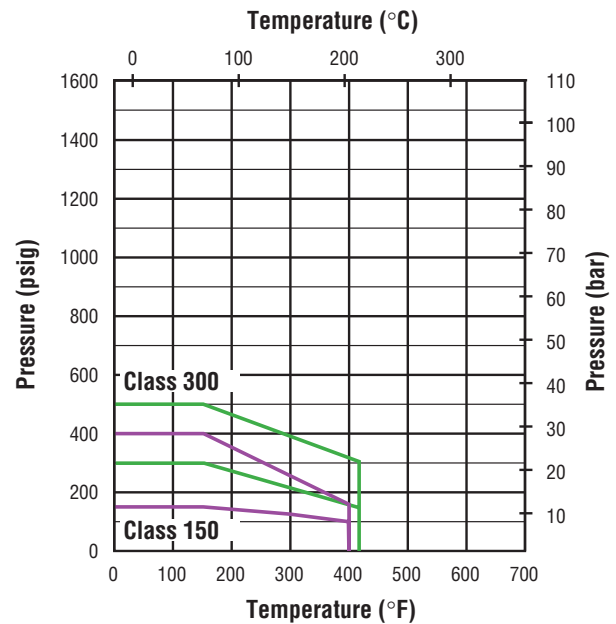

- Bronze – Body Rating
- Aluminum – Body Rating

ANSI Class 150285 psig (19.4 bar)
ANSI Class 300740 psig (50.3 bar)
ANSI Class 6001480 psig (100.7 bar)
ANSI Class 9002220 psig (151.0 bar)
ANSI Class 15003750 psig (255.1 bar)

* Maximum 100°F working pressure for Carbon Steel (ANSI B16.34).

Maximum seat temperature limit depending on pressure:

L = CeraMc1500°F (816°C)
M = Metal1500°F (816°C)
G = Carbon-graphite (non-oxidizing)1000°F (538°C)
G = Carbon-graphite (oxidizing)700°F (371°C)
V = Polyimide650°F (343°C)
J = Carbon-filled PEEK600°F (316°C)
W = Hi-Load Fire-Seal seats TFE550°F (288°C)
R = RTFE525°F (274°C)
T = TFE450°F (232°C)
K = Kel-F300°F (149°C)
Z = TEFZEL525°F (274°C)
3 = ZYMAXX575°F (302°C)
U = Fire-seal RTFE525°F (274°C)

Performance Data

Flow Coefficient (Cv) Versus Valve Size

Flanged Valves

Valve Size (in.)	Class 150	Full Port Class 150	Class 300	Full Port Class 300	Class 600	Full Port Class 600	Class 900	Class 1500
½	26	—	26	—	26	—	—	—
¾	55	—	55	—	55	—	16	16
1	55	63	51	61	46	54	27	27
1½	110	159	110	154	103	138	91	91
2	188	306	184	300	175	282	155	155
3	397	763	449	731	420	696	400	380
4	600	1430	720	1404	790	1355	740	640
6	1500	3548	1500	3522	1600	3339	1600	1550
8	2800	6148	2800	6004	2800	5779	3000	3000
10	4700	9684	4700	9684	4600	9368	—	4100
12	6600	14327	6600	14327	—	13964	—	—
14	7550	—	7550	—	—	—	—	—
16	9500	—	9500	—	—	—	—	—
18	14850	—	15150	—	—	—	—	—

Flanged Valves

Valve Size (in.)	Class 300	Class 600
½	17	17
¾	26	26
1	35	35
1½	70	70
2	120	120
3	240	—

Butt Weld Valves

Valve Size (in.)	Class 300	Class 600
½	17	—
¾	26	—
1	35	—
1½	70	—
2	120	—
3	400	410
4	720	780
6	1500	1700
8	2500	3100
10	3800	—

Cv values are for 100% open valve. For additional information, including Cv values for incremental valve positions, refer to McCANNA's "Flow Manual for Quarter-Turn Valves"

Dimensions and Weights

Regular Port Class 150 — Flanged Ends – S151 Configuration

Size in/mm	A ¹	A ²	A ³	B ¹	B ²	C	D	Weight [Ⓣ] lb/kg
1/4	5.62	—	5.50	3.60	4.85	.81	6.50	7
15	142.0	—	139.7	91.4	123.2	20.6	165.1	3.2
3/4	4.62	—	4.50	3.70	4.95	.81	6.50	7
20	117.3	—	114.3	94.0	125.7	20.6	165.1	3.2
1	5.00	5.50	4.88	3.77	5.02	.81	6.50	8
25	127.0	139.7	124.0	95.8	127.5	20.6	165.1	3.6
1 1/2	6.50	7.00	6.38	4.44	5.94	1.19	8.50	13
40	165.1	177.8	162.1	112.8	150.9	30.2	215.9	5.9
2	7.00	7.50	6.88	4.86	6.61	1.50	12.20	20
50	177.8	190.5	174.7	123.4	167.9	38.1	309.6	9.0
3	8.00	8.50	7.88	6.27	8.27	2.25	15.00	41
80	203.2	215.9	200.2	159.3	210.1	57.2	381.0	18.5
4	9.00	9.50	8.88	7.77	9.77	3.00	20.00	70
100	228.6	241.3	225.5	197.4	248.2	76.2	508.0	31.5
6	15.50	16.00	15.38	10.16	12.16	4.50	32.00	166
150	393.7	406.4	390.6	258.1	308.9	114.3	812.8	74.7
8	18.00	18.50	17.88	15.13	17.13	6.00	42.00	284
200	457.2	469.9	454.2	384.33	435.1	152.4	1066.8	128
10	21.00	21.50	20.88	15.5*	N/A	7.50	N/A	635
250	533.4	546.1	530.4	394.5*	N/A	190.5	N/A	286
12	24.00	24.50	23.88	18.55*	N/A	9.00	N/A	1150
300	609.6	622.3	606.6	471.2*	N/A	228.6	N/A	518
14	27.00	27.50	26.88	20.37*	N/A	10.50	N/A	1602
350	685.8	698.5	682.8	517.4*	N/A	266.7	N/A	721
16	37.50	38.00	37.38	22.42*	N/A	12.00	N/A	N/A
400	952.5	965.2	949.5	569.5*	N/A	304.8	N/A	N/A
18	42.00	42.50	41.88	25.18*	N/A	14.00	N/A	N/A
450	1066.8	1079.5	1063.8	639.6	N/A	355.6	N/A	N/A

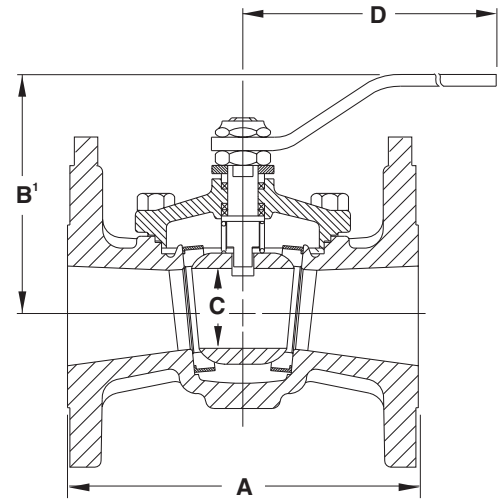

Regular Port Class 300 — Flanged Ends – S301 Configuration

Size in/mm	A ¹	A ²	A ³	B ¹	B ²	C	D	Weight [Ⓣ] lb/kg
1/4	5.50	N/A	5.38	3.60	4.85	.81	6.50	8
15	139.7	N/A	136.6	91.4	123.2	20.6	165.1	3.6
3/4	6.00	6.38	5.88	3.80	5.05	.81	6.50	9
20	152.4	162.1	149.4	96.5	128.3	20.6	165.1	4.1
1	6.50	7.00	6.38	3.85	5.10	.81	6.50	11
25	165.1	177.8	162.1	97.8	129.5	20.6	165.1	5.0
1 1/2	7.50	8.00	7.38	4.46	5.96	1.19	8.50	19
40	190.5	203.2	187.5	113.3	151.4	30.2	215.9	8.6
2	8.50	9.12	8.38	4.93	6.68	1.50	12.20	26
50	215.9	231.7	212.8	125.2	169.7	38.1	309.6	11.7
3	11.12	11.75	11.00	6.46	8.46	2.25	15.00	59
80	282.4	298.5	279.4	164.1	214.9	57.2	381.0	26.6
4	12.00	12.62	11.88	7.77	9.77	3.00	20.00	95
100	304.8	320.6	301.7	197.4	248.2	76.2	508.0	42.8
6	15.88	16.50	15.88	10.16	12.16	4.50	32.00	171
150	403.4	419.1	403.4	258.1	308.9	114.3	812.8	77.0
8	19.75	20.38	19.63	15.13	17.13	6.00	42.00	350
200	501.6	517.7	498.6	384.3	435.1	152.4	1066.8	158
10	22.38	23.00	22.25	15.53*	N/A	7.50	N/A	675
250	568.5	584.2	565.2	394.5*	N/A	190.5	N/A	304
12	25.50	26.12	25.38	18.55*	N/A	9.00	N/A	1360
300	647.7	663.4	644.7	471.2*	N/A	228.6	N/A	612
14	30.00	30.62	29.88	20.37*	N/A	10.50	N/A	1915
350	762.0	777.7	759.0	517.4*	N/A	266.7	N/A	862
16	39.00	39.62	38.88	22.42*	N/A	12.00	N/A	N/A
400	990.6	1006.3	987.6	569.5*	N/A	304.8	N/A	N/A
18	42.00	42.62	41.88	25.18*	N/A	14.00	N/A	N/A
450	1066.8	1082.5	1063.8	639.6*	N/A	355.6	N/A	N/A

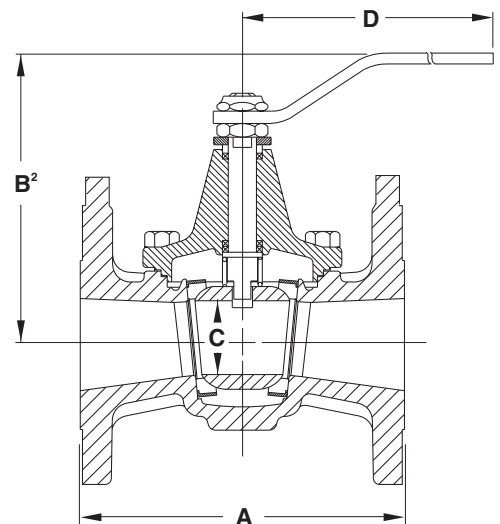

Notes: A¹ = raised face A² = ring type joint A³ = flat faced
B¹ = standard bonnet B² = extended bonnet

* Dimensions shown with asterisk are to top of stem. Handle not offered. Flange ends conform to ANSI specifications B16.5. Flange facing finish is 125–250 Micro-inches Ra.

◇ All weights are approximate for steel. See page 17 for alloy weight conversion factors.

Regular Port Class 600 — Flanged Ends – S601 Configuration

Size in/mm	A ¹	A ²	A ³	B	C	D	Weight [◇] lb/kg
½ 15	6.50 165.1	6.44 163.6	6.00 152.4	5.26 133.6	.81 20.6	8.50 215.9	10 4.5
¾ 20	7.50 124.0	7.50 190.5	7.00 177.8	5.26 133.6	.81 20.6	8.50 215.9	10 4.5
1 25	8.50 215.9	8.50 215.9	8.00 203.2	5.26 133.6	.81 20.6	8.50 215.9	16 7.2
1½ 40	9.50 241.3	9.50 241.3	9.00 228.6	6.21 157.7	1.17 29.7	12.19 309.6	28 12.6
2 50	11.50 292.1	11.62 295.2	11.00 279.4	7.05 179.1	1.50 38.1	15.00 381.0	40 18.0
3 80	14.00 355.6	14.12 358.7	13.50 342.9	8.90 226.1	2.25 57.2	20.00 508.0	78 35.1
4 100	17.00 431.8	17.12 434.9	16.50 419.1	10.11 256.8	3.00 76.2	32.00 812.8	153 68.9
6 150	22.00 558.8	22.12 561.9	21.50 546.1	13.09 332.5	4.50 114.3	57.00 1447.8	320 144
8 200	26.00 660.4	26.12 663.5	25.50 647.7	15.39* 390.9*	6.00 152.4	N/A N/A	520 234
10 250	31.00 787.4	31.12 790.5	30.50 774.7	17.76* 451.1*	7.50 190.5	N/A N/A	1000 450

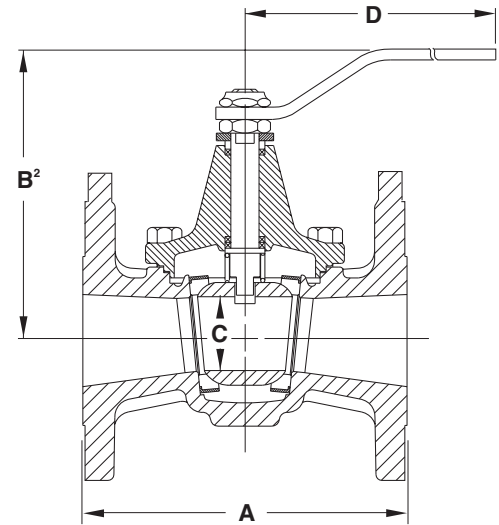

Regular Port Class 900† — Flanged Ends – S901 Configuration

Size in/mm	A ¹	A ²	A ³	B	C	D	Weight [◇] lb/kg
3 80	15.00 381.0	15.12 384.1	14.50 368.3	9.66 245.4	2.25 57.2	20.00 508.0	150 67.5
4 100	18.00 457.2	18.12 460.3	17.50 444.5	12.82 325.6	3.00 76.2	57.00 1447.8	260 117
6 150	24.00 609.6	24.12 612.7	23.50 596.9	14.34* 364.2*	4.50 114.3	N/A N/A	600 270
8 200	29.00 737.0	29.12 739.7	28.50 724.0	16.96* 430.8*	6.00 152.4	N/A N/A	1175 529

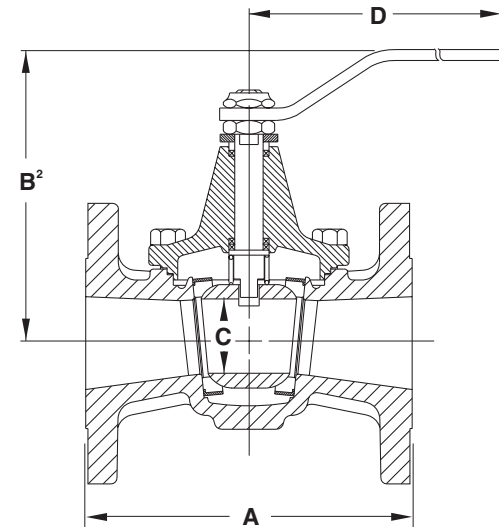

Regular Port Class 1500† — Flanged Ends – S1501 Configuration

Size in/mm	A ¹	A ²	A ³	B	C	D	Weight [◇] lb/kg
½ 15	9.50 241.3	9.50 241.3	9.00 228.6	6.41 162.8	.81 20.6	12.19 309.6	.27 12.2
¾ 20	9.75 247.7	9.75 247.7	9.25 235.0	6.41 162.8	.81 20.6	12.19 309.6	30 13.5
1 25	10.00 254.0	10.00 254.0	9.50 241.3	6.41 162.8	.81 20.6	12.19 309.6	35 15.8
1½ 40	12.00 304.8	12.00 304.8	11.50 291.1	8.22 208.8	1.17 29.7	15.00 381.0	70 31.5
2 50	14.50 368.3	14.62 371.4	14.00 355.6	8.63 219.2	1.50 38.1	20.00 508.0	105 47.3
3 80	18.50 469.9	18.62 473.0	18.00 457.2	11.57 293.9	2.25 57.2	20.00 508.0	260 117
4 100	21.50 546.1	21.62 549.1	21.00 533.4	13.94* 351.5*	3.00 76.2	N/A N/A	400 180
6 150	27.75 704.9	28.00 711.2	27.25 692.2	15.96* 405.4*	4.50 114.3	N/A N/A	960 432
8 200	32.75 831.9	33.12 841.3	32.25 819.2	21.17* 537.7*	6.00 152.4	N/A N/A	1700 765
10 250	39.00 990.6	39.38 1000.3	38.50 977.9	23.75* 603.3*	7.50 190.5	N/A N/A	N/A N/A

Notes: Extended bonnet standard on Class 600, 900 & 1500.
 A¹ = raised face A² = ring type joint A³ = flat faced
 Flange ends conform to ANSI specifications B16.5.
 See page 17 for alloy weight conversion factors.

† Available with metal or carbon graphite seats only.
 * Dimensions shown with asterisk are to top of stem.
 Handle not offered.

◇ All weights are approximate for steel.

Dimensions and Weights *(continued)*

Full Port Class 150 — Flanged Ends – S1F1 Configuration

Size in/mm	A ¹	A ²	B ¹	B ²	C	D	Weight [†] lb/kg
1 25	7.00 177.8	7.50 190.5	4.68 118.9	6.18 157.0	1.19 30.2	8.50 215.9	13 5.9
1½ 40	8.75 222.3	9.25 235.0	5.11 129.8	6.86 174.2	1.50 38.1	12.19 309.6	20 9.0
2 50	10.50 266.7	11.00 279.4	6.72 170.7	8.72 221.5	2.25 57.2	15.00 381.0	41 18.5
3 80	13.50 342.9	14.00 355.6	8.30 210.8	10.30 261.6	3.00 76.2	20.00 508.0	70 31.5
4 100	17.00 431.8	17.50 444.5	10.79 274.1	12.79 324.9	4.50 114.3	32.00 812.8	166 74.7
6 150	21.50 546.1	22.00 558.8	15.55 395.0	17.55 445.8	6.00 152.4	42.00 1066.8	284 128
8 200	24.50 622.3	25.00 635.0	*15.70 398.8	N/A N/A	8.00 203.2	N/A N/A	635 286
10 250	32.50 825.5	33.00 838.2	*21.46 545.1	N/A N/A	10.00 254.0	N/A N/A	940 423
12 300	38.00 965.2	38.50 977.9	*21.94 557.3	N/A N/A	12.00 304.8	N/A N/A	1680 756
14 350	41.75 1060.5	41.88 1063.8	*25.42 645.7	N/A N/A	14.00 355.6	N/A	

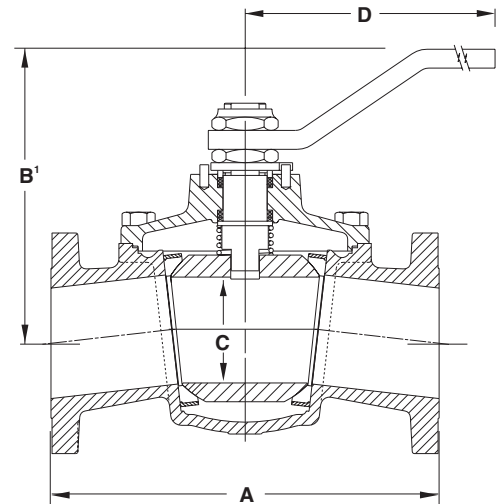

Full Port Class 300 — Flanged Ends – S3F1 Configuration

Size in/mm	A ¹	A ²	B ¹	B ²	C	D	Weight [†] lb/kg
1 25	7.50 190.5	8.00 203.2	4.71 119.6	6.21 157.7	1.19 30.2	8.50 215.9	19 8.6
1½ 40	9.50 241.3	10.00 254.0	5.15 130.9	6.90 175.3	1.50 38.1	12.19 309.6	26 11.7
2 50	11.12 282.5	11.75 298.5	6.75 171.5	8.75 222.3	2.25 57.2	15.00 381.0	59 26.6
3 80	15.25 387.4	15.88 403.4	8.39 213.1	10.39 263.9	3.00 76.2	20.00 508.0	95 42.8
4 100	18.00 457.2	18.62 473.0	10.87 276.1	12.87 326.9	4.50 114.3	32.00 812.8	171 77.0
6 150	22.00 558.8	22.62 574.5	15.58 395.7	17.58 446.5	6.00 152.4	42.00 1066.8	350 158
8 200	27.00 685.8	27.62 701.5	*15.88 403.4	N/A N/A	8.00 203.2	N/A N/A	675 304
10 250	32.50 825.5	33.12 841.2	*21.46 545.1	N/A N/A	10.00 254.0	N/A N/A	1025 462
12 300	38.00 965.2	38.62 981.0	*21.94 557.3	N/A N/A	12.00 304.8	N/A N/A	1770 797
14 350	41.75 1060.5	41.88 1063.8	*25.42 645.7	N/A N/A	14.00 355.6	N/A	

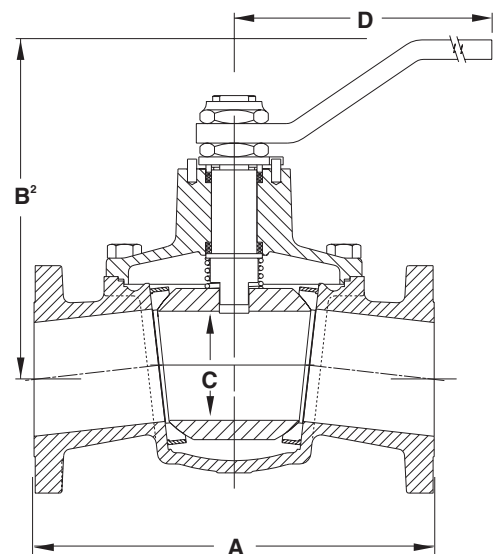

Full Port Class 600 — Flanged Ends – S6F1 Configuration

Size in/mm	A ¹	A ²	B ²	C	D	Weight [‡] lb/kg
1 25	10.00 254.0	10.00 254.0	6.11 155.2	1.19 30.2	12.19 309.6	28 12.6
1½ 40	12.50 317.5	12.50 317.5	7.41 188.2	1.50 38.1	15.00 381.0	40 18.0
2 50	13.00 330.2	13.12 333.3	9.10 231.1	2.25 57.2	20.00 508.0	78 35.1
3 80	17.50 444.5	17.62 447.6	9.78 248.4	3.00 76.2	32.00 812.8	153 68.9
4 100	20.00 508.0	20.12 511.1	13.51 343.2	4.50 114.3	57.00 1447.8	320 144
6 150	26.00 660.4	26.12 663.5	*15.90 403.9	6.00 152.4	N/A	520 234
8 200	31.25 793.8	31.38 797.1	*18.48 469.4	8.00 203.2	N/A	1000 450
10 300	37.00 939.8	37.12 942.8	*20.76 527.3	10.00 254.0	N/A	
12 400	42.00 1066.8	42.12 1069.8	*22.78 578.6	12.00 304.8	N/A	

Notes: A¹ = raised face A² = ring type joint
 B¹ = standard bonnet B² = extended bonnet
 *Dimensions shown with asterisk are to top of stem.
 Handle not offered. Flange ends conform to ANSI
 specifications B16.5. Flange facing finish is 125–250
 Micro-inches Ra. Lower dimensions are millimeters, kg,
 or DN for valve size.

‡All weights are approximate for steel. See page 17 for
 alloy weight conversion factors. For sizes not shown
 contact Flowserve.

Regular Port Class 300 — Threaded and Socket End, S302 & S303 Configurations

Size in/mm	A ¹	A ²	B ¹	B ²	C	D	E	F	Weight [◇] lb/kg
½ 15	4.19 106.4	5.56 141.2	3.69 93.7	4.94 125.5	.81 20.6	6.50 165.1	.865/.855 22.0/21.7	.38 9.7	4 1.8
¾ 20	3.81 96.8	3.81 96.8	3.69 93.7	4.94 125.5	.81 20.6	6.50 165.1	1.075/1.065 27.3/27.1	.50 12.7	4 1.8
1 25	3.81 96.8	3.81 96.8	3.69 93.7	4.94 125.5	.81 20.6	6.50 165.1	1.340/1.330 34.0/33.8	.50 12.7	4 1.8
1-½ 40	4.75 120.6	4.75 120.6	4.50 114.3	6.00 152.4	1.19 30.2	8.50 215.9	1.925/1.915 48.9/48.6	.50 12.7	7 3.2
2 50	5.62 142.7	5.50 139.7	4.84 122.9	6.59 167.4	1.50 38.1	12.19 309.6	2.421/2.406 61.5/61.1	.62 15.7	11 5.0
3 80	8.19 208.0	8.00 203.2	6.38 162.1	8.48 212.9	2.25 57.2	15.00 381.0	3.550/3.535 90.2/89.8	.62 15.7	29 13.1

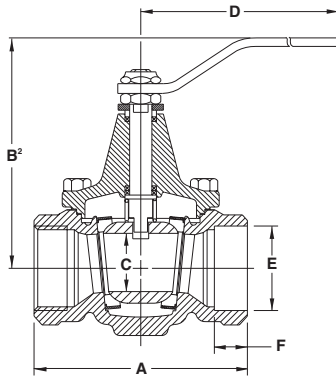

Regular Port Class 600 — Threaded and Socket End, Extended Bonnet, S602 & S603 Configurations

Size in/mm	A ¹	A ²	B ¹	B ²	C	D	E	F	Weight [◇] lb/kg
½ 15	4.75 120.6	4.75 120.6	N/A	5.06 128.5	.81 20.6	6.50 165.1	.865/.855 22.0/21.7	.38 9.7	11 5.0
¾ 20	4.38 111.3	4.25 108.0	N/A	5.06 128.5	.81 20.6	6.50 165.1	1.075/1.065 27.3/27.1	.50 12.7	10 4.5
1 25	4.25 108.0	4.25 108.0	N/A	5.06 128.5	.81 20.6	6.50 165.1	1.340/1.330 34.0/33.8	.50 12.7	10 4.5
1-½ 40	5.12 130.0	5.12 130.0	N/A	6.16 156.5	1.19 30.2	8.50 215.9	1.925/1.915 48.9/48.6	.50 12.7	18 8.1
2 50	5.88 149.4	5.75 146.1	N/A	6.72 170.7	1.50 38.1	12.19 309.6	2.421/2.406 61.5/61.1	.62 15.7	30 13.5

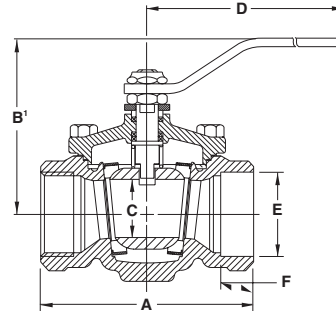

Regular Port Class 600 — Butt Weld Ends, S604 Configuration

Size in/mm	A	B ¹	B ²	C	D	Weight [◇] lb/kg
3 80	14.00 355.6	N/A	8.59 218.2	2.25 57.2	20.00 508.0	52 23.4
4 100	17.00 431.8	N/A	10.22 259.6	3.00 76.2	32.00 812.8	100 45.0
6 150	22.00 558.8	N/A	12.69 322.3	4.50 114.2	57.00 1447.8	190 85.5
8 200	26.00 660.4	N/A	15.38* 390.6*	6.00 152.4	N/A	400 180.0

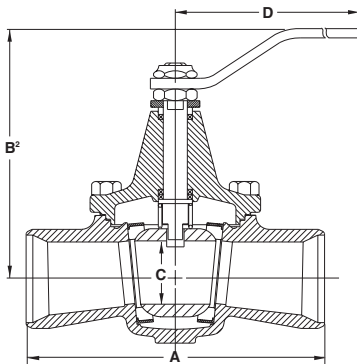

Regular Port Class 300 — Butt Weld Ends, S304 Configuration

Size in/mm	A	B ¹	B ²	C	D	Weight [◇] lb/kg
½ 15	7.44 189.0	3.69 93.7	4.94 125.5	.81 20.6	6.50 165.1	3 1.4
¾ 20	7.44 189.0	3.69 93.7	4.94 125.5	.81 20.6	6.50 165.1	3 1.4
1 25	3.44 87.4	3.59 91.2	4.84 122.9	.81 20.6	6.50 165.1	3 1.4
1-½ 40	4.75 120.7	4.50 114.3	6.00 152.4	1.19 30.2	6.50 165.1	5 2.3
2 50	5.62 143.0	4.84 123.0	6.59 167.4	1.50 38.1	12.19 309.6	9 4.1
3 80	11.12 282.4	6.25 158.8	8.25 209.6	2.25 57.2	15.00 381.0	32 14.4
4 100	12.00 304.8	8.03 203.9	10.03 254.8	3.00 76.2	20.00 508.0	53 23.9
6 150	15.88 403.4	10.16 258.1	12.16 308.9	4.50 114.3	32.00 812.8	124 55.8
8 200	20.50 520.7	15.06 382.5	17.06 433.3	6.00 152.4	42.00 1066.8	213 95.9
10 250	22.06 560.3	15.52 394.2	N/A	7.50 190.5	N/A	405 182.3

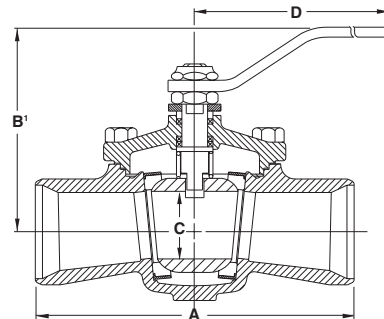

Alloy Weight Conversion Factors

Material	Multiplier	Material	Multiplier
Alloy 20	1.0	Monel & Nickel	1.1
Aluminum	0.5	Stainless Steel	1.0
Bronze	1.1	Titanium	.65
Hastelloy "C"	1.0		

Notes: Extended bonnet standard on Class 600 & 1500.

A¹ = threaded end A² = socket end B¹ = standard bonnet

B² = extended bonnet E = socket diameter F = socket depth

Threaded ends per ANSI B1.20.1 Socket ends per ANSI spec B16.11.

◇ All weights are approximate for steel. See chart at left for alloy weight conversion factors.

Materials of Construction

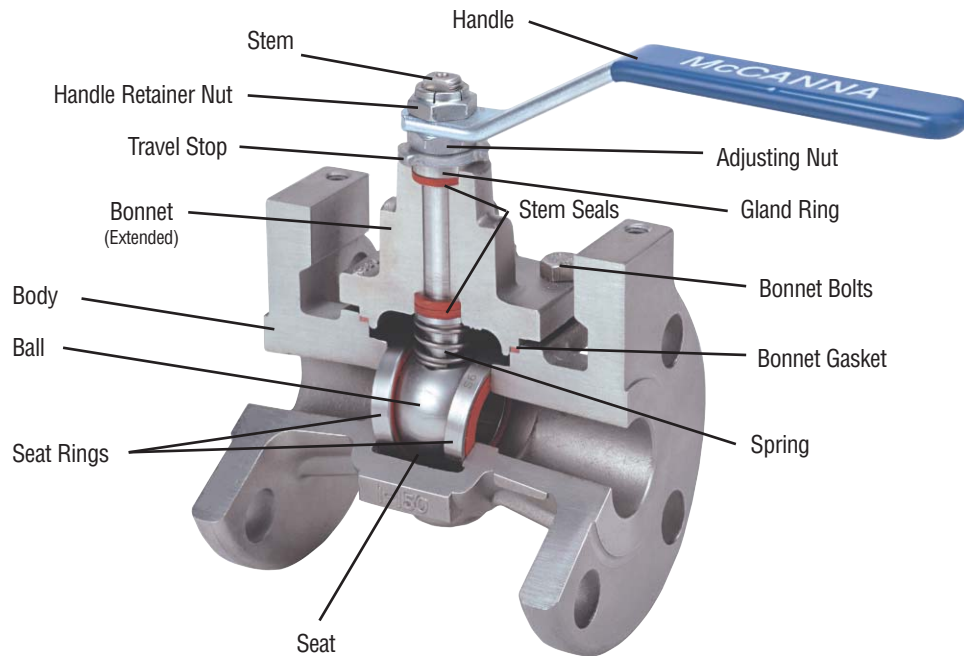

Regular Port ANSI Class 150, Class 300, Class 600, Class 900 and Class 1500

Part Description	Alloy 20	Bronze	Carbon Steel	Hastelloy C	Monel	Nickel	Stainless Steel	Titanium
Body—Threaded or flanged ends	ASTM A351 Gr. CN-7M	ASTM B62/B584 Gr. C83600	ASTM A216† Gr. WCB	ASTM A494 Gr. CW-12M	ASTM A494 Gr. M35-1	ASTM A494 Gr. CZ100	ASTM A351 Gr. CF 8M	ASTM B367 Gr. C3
Body—Socket or butt weld ends	ASTM A351 Gr. CN-7M	ASTM B62/B584 Gr. C83600	ASTM A216† Gr. WCB	ASTM A494 Gr. CW-12M	ASTM A494 Gr. M35-1	ASTM A494 Gr. CZ100	ASTM A351 Gr. CF 3M	ASTM B367 Gr. C3
Bonnet*	ASTM A351 Gr. CN-7M ASTM B473 UNS N08020	ASTM B62 85-5-5-5 ASTM B21● UNS C48500	ASTM A216† Gr. WCB ASTM A181† Gr. 70	ASTM A494 Gr. CW-12M ASTM B574 UNS N10276	ASTM A494 Gr. M35-1 Alloy K500	ASTM A494 Gr. CZ100 ASTM B160 Alloy 200	ASTM A351 Gr. CF 8M ASTM A479 Type 316	ASTM B367 Gr. C3 CAST ASTM B367 GRC3 FORG ASTM B381 GR F-3 BAR ASTM B348 GR 4
Ball*	ASTM B351 Gr. CN-7M	ASTM B16● 85-5-5-5	ASTM A479 Type 316 ASTM A351 Gr. CF 8M	ASTM B494 Gr. CW-12M	Alloy 501 Alloy 411	ASTM A494 Gr. CZ100	ASTM A351 Gr. CF 8M	ASTM B348 Gr. 4
Stem	ASTM B473 UNS N08020	ASTM B21● UNS C48500	ASTM A276†† Type 316 CFB (1/2-3") CFA (4-10")	ASTM B574 UNS N10276	Alloy K500	Inconel 625	ASTM A276†† Type 316 CFB (1/2-3") CFA (4-10")	ASTM B358 Gr. 4
Spring T and R Seat	Inconel X750	ASTM A313 Type 316	ASTM A313 Type 316	Inconel X750	Inconel 625	Inconel 625	ASTM A313 Type 316	ASTM B348 Gr. 5
Spring all other Seats	Inconel X750	Inconel X750	Inconel X750	Inconel X750	Inconel 625	Inconel 625	Inconel X750	ASTM B348 Gr. 5
Seat Ring	ASTM B473 UNS N08020	ASTM A312 Gr. TP316	ASTM A312 Gr. TP316	ASTM B574 UNS N10276 (1/2-1") ASTM B619 UNS N10276(1-1/2-10")	Alloy K500 or Alloy 501	ASTM B161 Alloy 200	ASTM A312 Gr. TP316	ASTM B338 Gr. 2
Bonnet Bolts	ASTM A193 Gr. B8M ◇	ASTM A193 Gr. B7 ◇	ASTM A193 Gr. B7 ◇	ASTM A193 Gr. B8M ◇	ASTM A193 Gr. B8M ◇	ASTM A193 Gr. B8M ◇	ASTM A193 Gr. B8M ◇	ASTM A193 Gr. B8M ◇

Notes: Consult Flowserve for materials of construction for configurations not listed.
 * Size of valve determines ASTM specification. Consult factory for specific information.
 † Black Oxide Coated
 ● Crack-free chrome plated
 †† Stem material for 600, 900 & 1500 Class valves is 17-4PH (ASTM A564, type 630).
 ◇ Size 1/2" – 2" Class 300 and 600 ASTM A453 GR660 Stainless Steel Capscrew used.

Materials of Construction

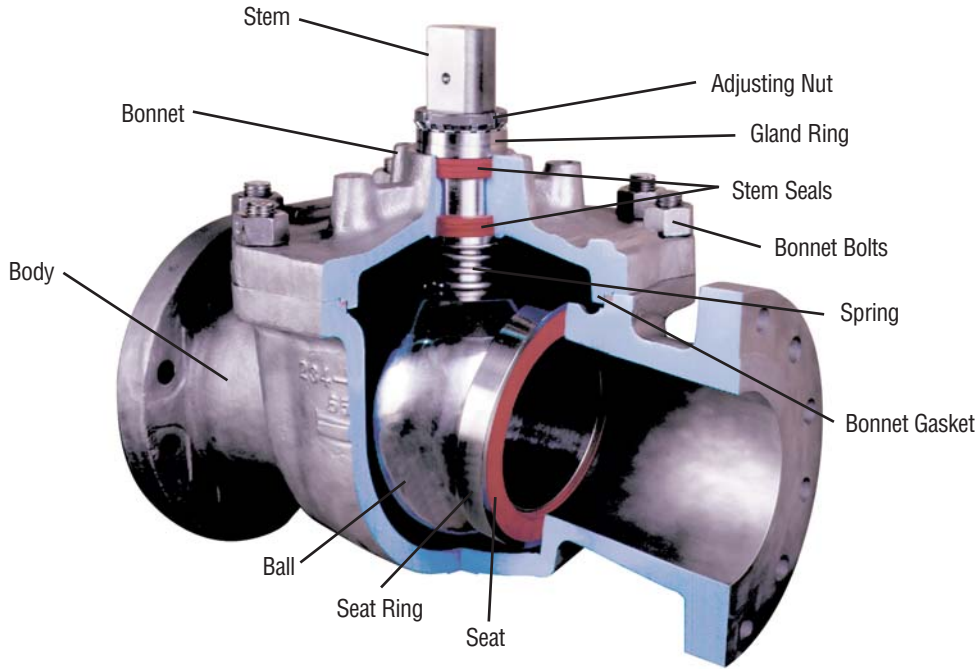

Full Port ANSI Class 150, Class 300, Class 600, Class 900 and Class 1500

Part Description	Alloy 20	Carbon Steel	Hastelloy C	Monel	Nickel	Stainless Steel	Titanium
Body	ASTM A351 Gr. CN-7M	ASTM A216† Gr. WCB	ASTM A494 Gr. CW-12M	ASTM A494 Gr. M35-1	ASTM A494 Gr. CZ100	ASTM A351 Gr. CF 8M	ASTM B367 Gr. C3
Bonnet*	ASTM A351 Gr. CN-7M	ASTM A216† Gr. WCB ASTM A181† Gr. 70	ASTM A494 Gr. CW-12M	ASTM A494 Gr. M35-1	ASTM A494 Gr. CZ100	ASTM A351 Gr. CF 8M	ASTM B367 Gr. C3
Ball*	ASTM B473■ UNS N08020 ASTM B351■ Gr. CN-7M	ASTM A479 Type 316 ASTM A351 Gr. CF 8M	ASTM B574 UNS N10276 ASTM B494 Gr. CW-12M	Alloy K500 or Alloy 501 Alloy 411	ASTM B160 Alloy 200 ASTM A494 Gr. CZ100	ASTM A479 Type 316 ASTM A351 Gr. CF 8M	ASTM B348 Gr. 4 ASTM B367 Gr. C3
Stem	ASTM B473■ UNS N08020	ASTM A276†† Type 316 CFB (1/2-3") CFA (4-10")	ASTM B574 UNS N10276	Alloy K500	Inconel 625	ASTM A276†† Type 316 CFB (1/2-3") CFA (4-10")	ASTM B358 Gr. 4
Spring T and R Seat	Inconel X750	ASTM A313 Type 316	Inconel X750	Inconel 625	Inconel 625	ASTM A313 Type 316	ASTM B348 Gr. 5
Spring all other Seats	Inconel X750	Inconel X750	Inconel X750	Inconel 625	Inconel 625	Inconel X750	ASTM B348 Gr. 5
Seat Ring	ASTM B473 UNS N08020	ASTM A312 Gr. TP316	ASTM B574 UNS N10276 (1/2-1") ASTM B619 UNS N10276(1-1/2-10")	Alloy K500 or Alloy 501	ASTM B161 Alloy 200	ASTM A312 Gr. TP316	ASTM B338 Gr. 2
Bonnet Bolts	ASTM A193 Gr. B8M ◇	ASTM A193 Gr. B7	ASTM A193 Gr. B8M ◇	ASTM A193 Gr. B8M ◇	ASTM A193 Gr. B8M ◇	ASTM A193 Gr. B8M ◇	ASTM A193 Gr. B8M ◇

Notes: Consult Flowserve for materials of construction for configurations not listed.
 * Size of valve determines ASTM specification. Consult factory for specific information.
 † Black Oxide Coated
 ■ Hard chrome plated
 †† Stem material for 600 Class valves is ASTM A564 type 6340 (17-PH).
 ◇ Size 1" Class 300 and 600 ASTM A453 GR660 Stainless Steel Capscrew used.

Automated McCannaseal Valve Packages

McCANNA Automated Control Packages are made to suit your requirements. Whether your application calls for simple on/off flow control or more sophisticated process automation, McCANNA offers a wide range of valve actuator packages to match individual requirements and provide excellent flexibility for automated flow control.



Electric Automation



The **Series 75** electric AC or DC actuator is designed for on/off and modulating applications. It provides precise, reliable, automatic rotary valve operation in a rugged compact package. The Series 75 is available in a variety of NEMA enclosures, and is easily adaptable for PLC/computer applications. Many options, such as feedback systems and positioner/controller, are available with torques up to 3000 in-lb.

Automated McCannaseal Valve Packages

Pneumatic Automation



The **Series 39** pneumatic actuator is an accurate, compact, powerful, double-piston, rack-and-pinion actuator with an impressive track record for reliability.



An **Integral Valve Control Unit** is available offering integral control and communication capabilities. The complete control unit consists of the Series 39 pneumatic actuator with integral limit switches, low wattage solenoid, manual override and LEDs to assist in calibration and to detect the status of system components. The entire control package is contained in an enclosure with a combined Type 4, 4x, 7, 9 and 12 rating.

This integral unit eliminates the need for expensive brackets and couplings commonly used with actuator accessories.

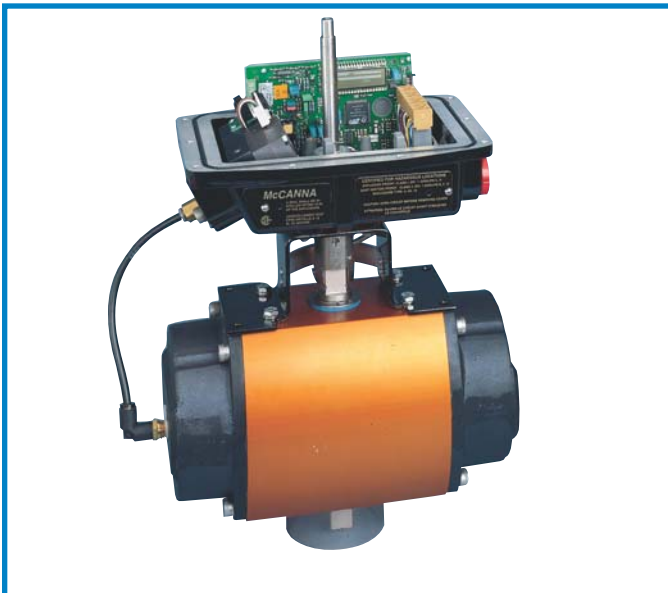

Loop Powered Positioner with auto calibration and zero air bleed. Operated by a 4-20 mA analog signal, this unit's microprocessor and three-button keypad provide on-site calibration, action, split-range, speed fault delay, etc.

How to Specify and Order

Furnishing the information below will speed deliveries of your orders for McCannaseal ball valves. Order by valve size and figure number.

McCANNA Ball Valve Figure No. Code System ⁽¹⁾							
Valve Size (inches)	I Type	II Pressure ⁽²⁾	III End Connection	IV Body Material ⁽¹⁾	V Standard Seats	VI Trim ⁽¹⁾⁽³⁾	VII Special Preparation
½	S - McCannaseal	15 - ANSI Class 150	1 - Flanged	AL - Aluminum	T - TFE	AL - Aluminum	Specify service or variation
¾	C - Cryogenic	30 - ANSI Class 300	RF or FF ⁽⁶⁾	A2 - Alloy 20	R - Reinforced TFE	A2 - Alloy 20	
1	Z - Fire-Seal	60 - ANSI Class 600	2 - Threaded	BR - Bronze	U - Reinforced TFE	BR - Bronze	
1½	Regular Port –	90 - ANSI Class 900	3 - Socket Weld	CS - Carbon Steel	Fire-Seal	HB - Hastelloy "B"	
2	½" thru 6" ⁽⁴⁾	150 - ANSI Class 1500	4 - Butt Weld ⁽⁶⁾	HB - Hastelloy "B"	W - HiLoad TFE	HC - Hastelloy "C"	
3	Y - Fire-Seal	1F - Full Port	6 - RTJ Flanged	HC - Hastelloy "C"	Fire-Seal	MO - Monel	
4	Regular Port –	ANSI Class 150	A - Threaded	MO - Monel	G - Carbon Graphite	N1 - Nickel	
6	8" and up	3F - Full Port	X Socket	NI - Nickel	J - Filled Peek	S6 - SS316	
8	Z - Fire-Seal	ANSI Class 300		S6 - SS316	M - Metal	SO - SS410	
10	Full Port – 1"	6F - Full Port		TI - Titanium	L - CeraMc	TI - Titanium	
12	thru 4" (4)	ANSI Class 600		6L - SS316L	3 - ZYMAXX	6L - SS316L	
14	Y - Fire-Seal			DS - Duplex SS		DS - Duplex SS	
16	Full Port – 6"					CERAMIC	
18	thru 12" ⁽⁴⁾					HC CA	
20						MO CM	
						AZ CA	

- Notes:** (1) This is basic Figure Number Code System only. Not all combinations available. Not all materials shown.
 (2) Nominal pressure rating only. Actual CWP ratings vary with construction and valve configurations.
 (3) Trim consists of ball, stem and seat ring.
 (4) Valves qualified to API-607 4th edition.
 (5) Standard flange finish 125–250 Micro-Inches Ra.
 (6) Specify pipe schedule.

Ordering Example:

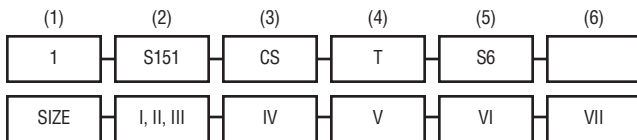

- (1) Valve size
 (2) Type, pressure class or group, and end connection from Column I, II, and III
 (3) Body material from Column IV
 (4) Seat from Column V
 (5) Trim from Column VI
 (6) Special preparation description

McCannaseal Product Ranges

Size		Class 150/PN 20		Class 300 / PN 50					Class 600 / PN 100					Class 900	Class 1500
in.	DN	Flanged	Full Port Flanged	Flanged	Full Port Flanged	Threaded	Socket	Butt Weld	Flanged	Full Port Flanged	Threaded	Socket	Butt Weld	PN 150 Flanged	PN250 Flanged
½	15	S151	—	S301	—	S302	S303	S304	S601	—	S602	S603	S604*	—	S1501
¾	20	S151	—	S301	—	S302	S303	S304	S601	—	S602	S603	S604*	—	S1501
1	25	S151	S1F1	S301	S3F1	S302	S303	S304	S601	S6F1	S602	S603	S604*	—	S1501
1½	40	S151	S1F1	S301	S3F1	S302	S303	S304	S601	S6F1	S602	S603	S604*	—	S1501
2	50	S151	S1F1	S301	S3F1	S302	S303	S304	S601	S6F1	S602	S603	S604*	—	S1501
3	80	S151	S1F1	S301	S3F1	S302	S303	S304	S601	S6F1	—	—	S604	S901	S1501
4	100	S151	S1F1	S301	S3F1	—	—	S304	S601	S6F1	—	—	S604	S901	S1501
6	150	S151	S1F1	S301	S3F1	—	—	S304	S601	S6F1	—	—	S604	S901	S1501
8	200	S151	S1F1	S301	S3F1	—	—	S304	S601	S6F1	—	—	S604	S901	S1501
10	250	S151	S1F1	S301	S3F1	—	—	S304	S601	S6F1	—	—	—	—	S1501
12	300	S151	S1F1	S301	S3F1	—	—	—	—	S6F1	—	—	—	—	—
14	350	S151	—	S301	—	—	—	—	—	—	—	—	—	—	—
16	400	S151	—	S301	—	—	—	—	—	—	—	—	—	—	—
18	450	S151	—	S301	—	—	—	—	—	—	—	—	—	—	—
20			—		—	—	—	—	—	—	—	—	—	—	—

- Notes:** Above available in standard or Fire-Seal qualified to API 607 4th Edition
 * For information on Class 600 Butt Weld ½" – 2", contact Flowserve.



Choose automated McCANNA control packages tailored to your requirements.

Where full automation is not needed, manual gear operators are available for all size and pressure classes of McCANNA Ball valves.



McCANNA ... All The Right Valves In All The Right Places

McCannaseal® Ball Valves

Top-of-the-line, top-entry ball valves with wedge-seat design are available in sizes ½" to 14" for pressures to 3750 psi. Available in a wide range of materials.

McCannaflo® Ball Valves

Economical, end-entry threaded end ball valves with patented prestressed, Fire-Seal® seats in sizes ¼" to 2" for pressures to 1200 psi.

McCANNA 800® Ball Valves

Standard ball valves that combine high-pressure reliability, low cost and Fire-Seal seats in sizes ¼" through 2" for pressures to 2000 psig.

McCANNA General Purpose Ball Valves

Sturdy, compact general purpose design available in brass or steel in sizes ¼" to 2" for pressures to 2000 psi.

Diaphragm Valves

Versatile, weir-type soft-seated valves provide leak-tight shutoff on sizes from ½" through 12" for pressures to 200 psi.

NOTICE: McCANNA Ball Valves are designed and manufactured using good workmanship and materials, and they meet all applicable industry standards. McCANNA is anxious to avoid injuries and property damage which could result from misapplication of the product. Proper valve selection is imperative. Examples of the misapplications or misuse of a valve include but are not limited to use in a service in which the pressure/temperature rating is exceeded or in a chemical service incompatible with the valve materials; use of undersized valve actuators; use of extremely fast valve actuation and/or continuous valve cycling on standard valves; making modifications of the product of any kind; failure to use caution in operating valves in high temperature, high pressure, or highly hazardous services; and the failure to maintain valves as recommended. The right is reserved to change or modify product design or construction without prior notice and without incurring any obligation to make such changes and modification on products previously or subsequently sold.

Cryoseal® is a registered trademark of M&FC Holding, Co., Inc.
 Fire-Seal® is a registered trademark of M&FC Holding, Co., Inc.
 McCannaseal® is a registered trademark of M&FC Holding, Co., Inc.
 McCANNAFLO® is a registered trademark of M&FC Holding, Co., Inc.
 Invensys® is a registered trademark of BTR SIEBE PIC
 McCANNA 800® is registered trademark of Weavex Corp.

Flowserve Corporation has established industry leadership in the design and manufacture of its products. When properly selected, this Flowserve product is designed to perform its intended function safely during its useful life. However, the purchaser or user of Flowserve products should be aware that Flowserve products might be used in numerous applications under a wide variety of industrial service conditions. Although Flowserve can (and often does) provide general guidelines, it cannot provide specific data and warnings for all possible applications. The purchaser/user must therefore assume the ultimate responsibility for the proper sizing and selection, installation, operation, and maintenance of Flowserve products. The purchaser/user should read and understand the Installation Operation Maintenance (IOM) instructions included with the product, and train its employees and contractors in the safe use of Flowserve products in connection with the specific application.

While the information and specifications contained in this literature are believed to be accurate, they are supplied for informative purposes only and should not be considered certified or as a guarantee of satisfactory results by reliance thereon. Nothing contained herein is to be construed as a warranty or guarantee, express or implied, regarding any matter with respect to this product. Because Flowserve is continually improving and upgrading its product design, the specifications, dimensions and information contained herein are subject to change without notice. Should any question arise concerning these provisions, the purchaser/user should contact Flowserve Corporation at any one of its worldwide operations or offices.

For more information about Flowserve Corporation, contact www.flowserve.com or call USA 1-800-225-6989.

FLOWSERVE CORPORATION
FLOW CONTROL DIVISION
 1978 Foreman Drive
 Cookeville, Tennessee 38501 USA
 Phone: 931 432 4021
 Facsimile: 931 432 3105
www.flowserve.com