

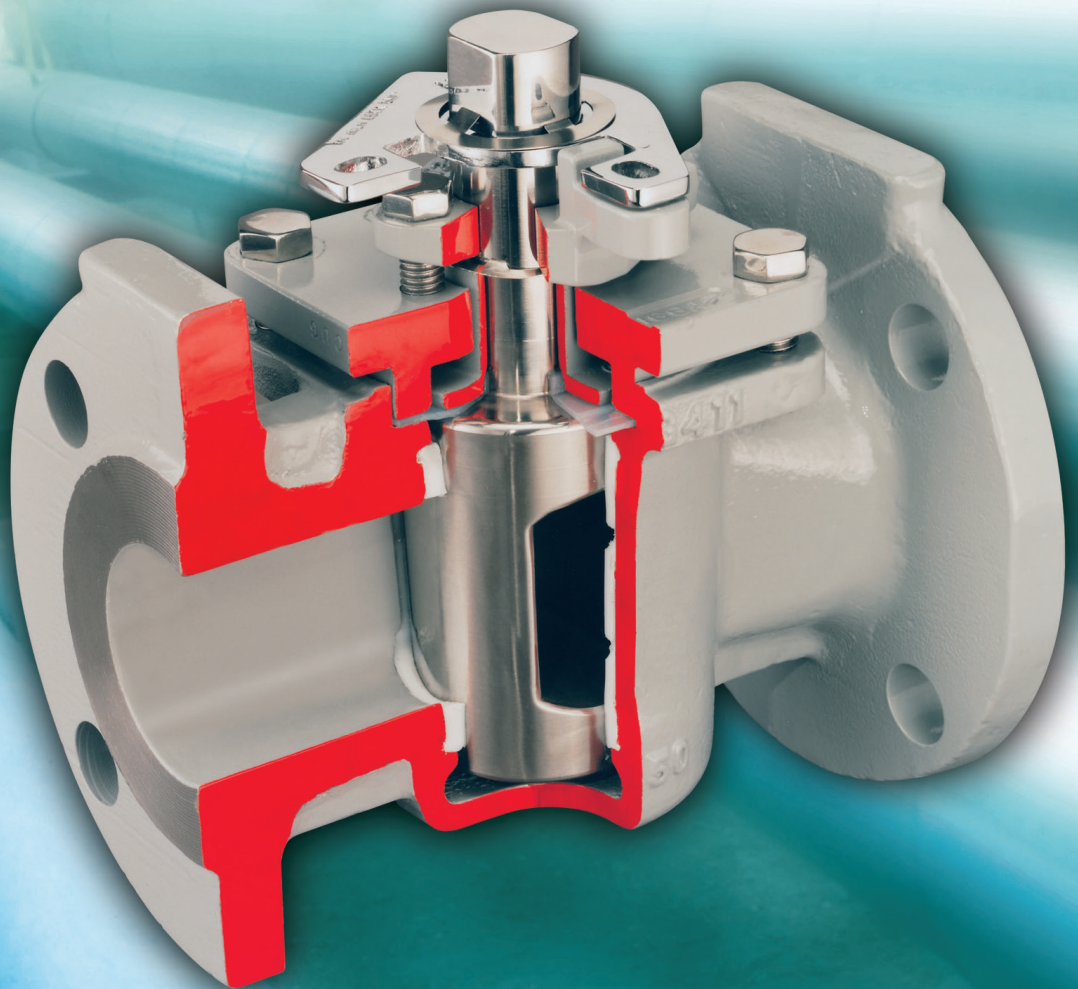

Durco® G4 SleeveLine Valves
Non-Lubricated Plug Valves
for Chemical Service



Experience In Motion



Index

	Page
G4 Sleeveless Valves	3
G4 Seal System	4
G4Z Fire Sealed	5
G4B Marathon	6
TSG4 Severe Service.....	8
G4 V-port Control Valves	10
Automated Systems	11
Special Configuration Valves.....	12
Pressure /Temperature Ratings	13
Drawing G4 and G4B Straightaway Valve Dimensions ...	14
Flow Indication for 3-way valves.....	16
Drawing MG4 and MG4B 3-way Valve dimensions.....	17
Drawing TSG4 Sleeveless Valve dimensions	18
PJG4 & PJG4B Jacketed Valve Dimensions	19
Drawing FJG4 and FJG4B Jacketed Valve Dimensions ...	20
Drawing G4 and G4B Screwed end Valve Dimensions ...	21
Drawing G4 and G4B Weld end Dimensions.....	22
Manual actuator and Trim Options	23
Parts and materials	25
How to Specify	27

Selection, Installation, Operation and Maintenance

Although Flowserve can, and often does, provide general guidelines, it is obviously not possible to provide application specific data and warnings for all conceivable applications. The purchaser/end user must therefore assume the ultimate responsibility for the proper selection, installation, operation and maintenance of the products. Read the appropriate IOM available from Cookeville,

TN 38501 before installing, operating or repairing any valve. The purchasers/end user should train its employees and/or contractors in the safe use of the Durco products in connection with the purchaser's manufacturing processes.

Design Changes

In order to follow the Flowserve commitment to continuous improvement, we reserve the right to change product and performance specifications without notice.



Durco® G4 SleeveLine Valves

Flowserve invented the non-lubricated plug valve for the most corrosive and difficult chemical services where drop-tight shutoff is an absolute requirement. Nearly 50 years later there are many imitators but no substitute for the quality and reliability, versatility and value you receive with SleeveLine valves.

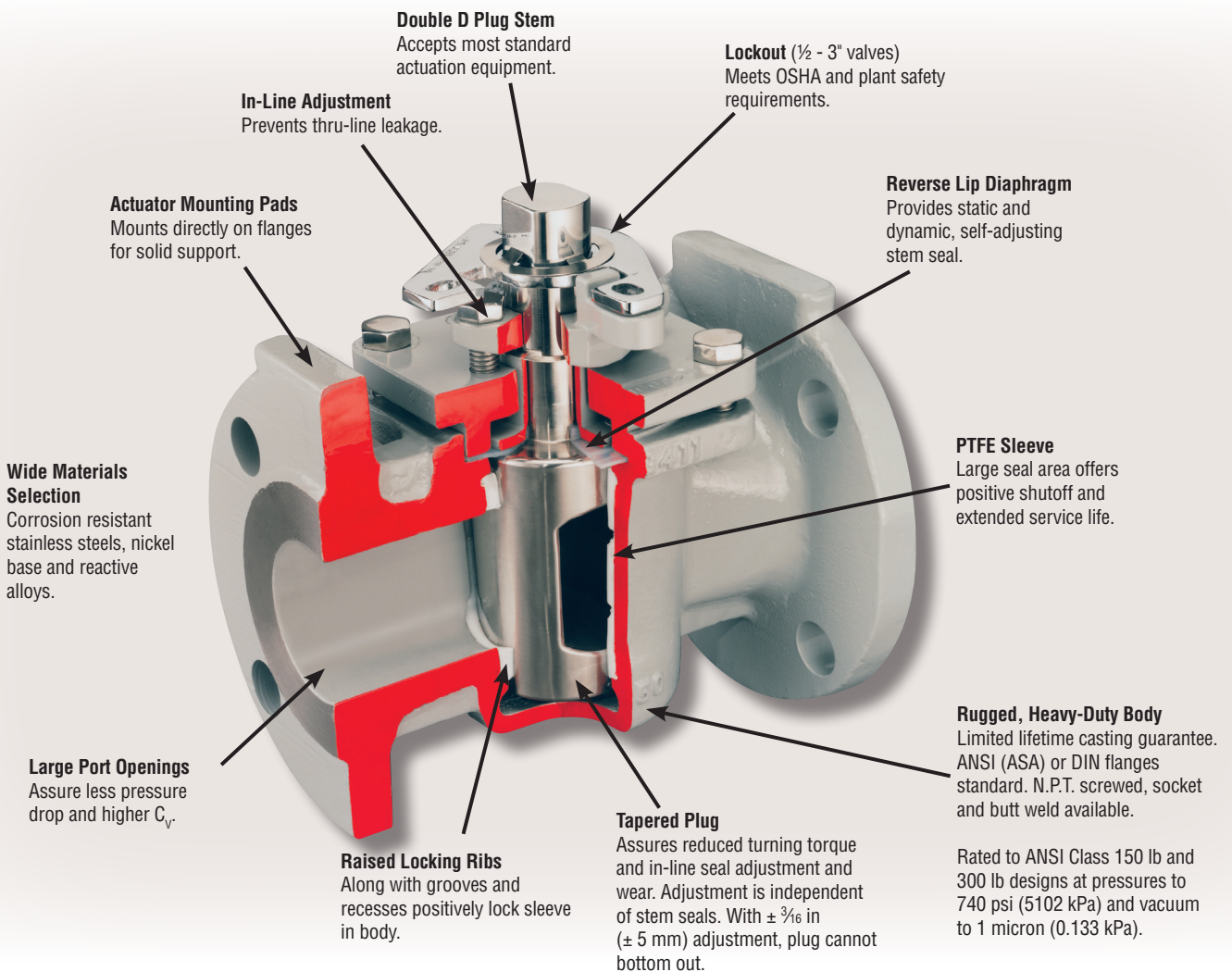

G4 Seal System

All G4 SleeveLine valves offer the proven reliability of the plug/PTFE sleeve primary seal with a fluoropolymer diaphragm secondary seal.

Positive Stem Seal

The unique fluoropolymer reverse lip diaphragm provides a self-energizing dynamic stem seal where pressure activates the reverse lip to seal against the stem. It also provides a static seal by wedging against the stem with an interference fit.

Line Sealing

The compressive, wedge fit of the tapered plug with the PTFE sleeve serves as the sealing surface. The sleeve totally surrounds plug ports and seals the circumference of the plug, top and bottom. There are no cavities to accumulate product. Sealing is both upstream and downstream.

- Seal is totally independent of line pressure.
- There is no metal-to-metal contact.
- Valve remains free-turning throughout its life and never requires lubrication.
- Seal is adjustable.
- Wiping action between sleeve and plug provides for good slurry handling.

In-Line, Thru-Line Seal Adjustability

In-line seal adjustment is achieved by turning two adjuster fasteners to drive the plug deeper into the sleeve. This saves maintenance and process time because the seal is adjusted in-line and under pressure within seconds. The result is repeatable, bubble-tight shutoff performance.

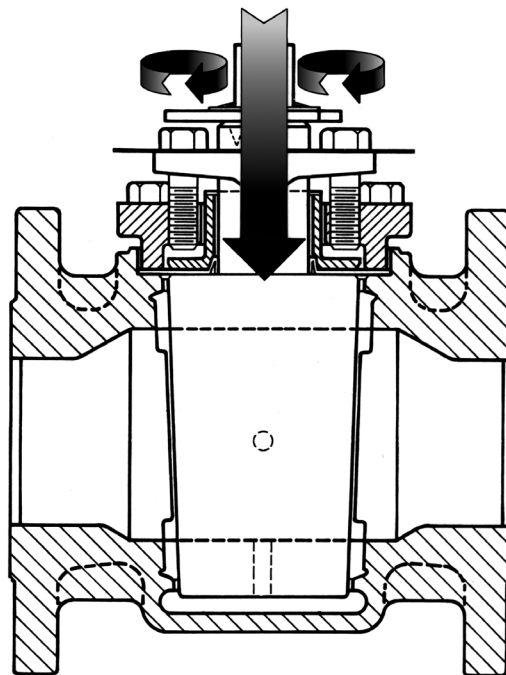

Durco G4Z Fire Sealed

Durco Sleeveless valves have been fire tested in accordance with API 607 Fourth Edition. They surpassed the external sealing requirements of Section 4, Paragraph 4.2, "Performance Requirements."

G4Z Fire Sealed Sleeveless valves incorporate special Grafoil® packing rings at the stem and Grafoil gaskets at the top cap. These reduce atmospheric leakage to a negligible amount should fire destroy the fluoropolymer sleeve and diaphragm. A metal diaphragm keeps the Grafoil packing in place if the top seal is destroyed.

See Bulletin V-25 for complete information about available G4Z-HF valve sizes and configurations; technical specifications; and appropriate industry standards compliance.

G4Z-HF Alkylation Valves Are Phillips Licensing Listed and UOP Process Division Approved

As an approved supplier for Phillips and UOP licensing, Flowserve has provided thousands of Durco HF alkylation valves to refineries throughout the world for services such as:

- Isomerization
- Blending
- Light ends
- Gas plant
- Sulfur plant
- Crude desalting

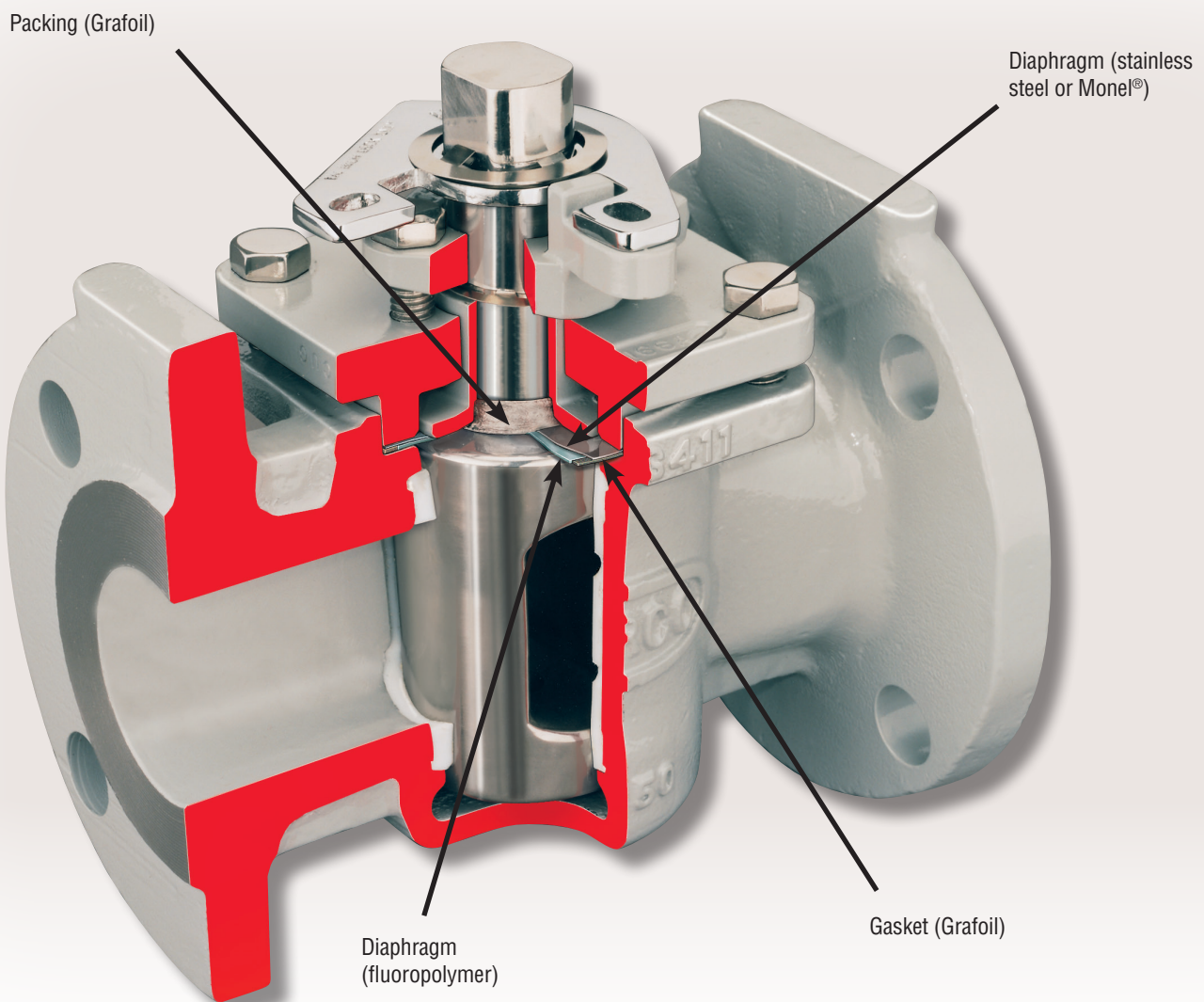

© Grafoil is a registered trademark of Union Carbide.
 © Monel is a registered trademark of the International Nickel Co., Inc.

Durco G4B Marathon™

The G4B Marathon is designed for reliable performance in high cycle on-off or modulating services. Fugitive emission containment is often equal to more expensive severe or toxic service valves.

Viton® O-rings

Full pressure containment stem seal. Also protects thrust collar from atmospheric corrosion. Kalrez® and other elastomers are available. PTFE backup rings help prevent extrusion of Viton O-rings under pressure.

Integral Thrust Collar/Alloy Diaphragm

Self-sealing, dynamic bellows-like diaphragm moves with plug adjustment to eliminate potential leak path. Hastelloy® (or optional materials) diaphragm welded to alloy thrust collar.

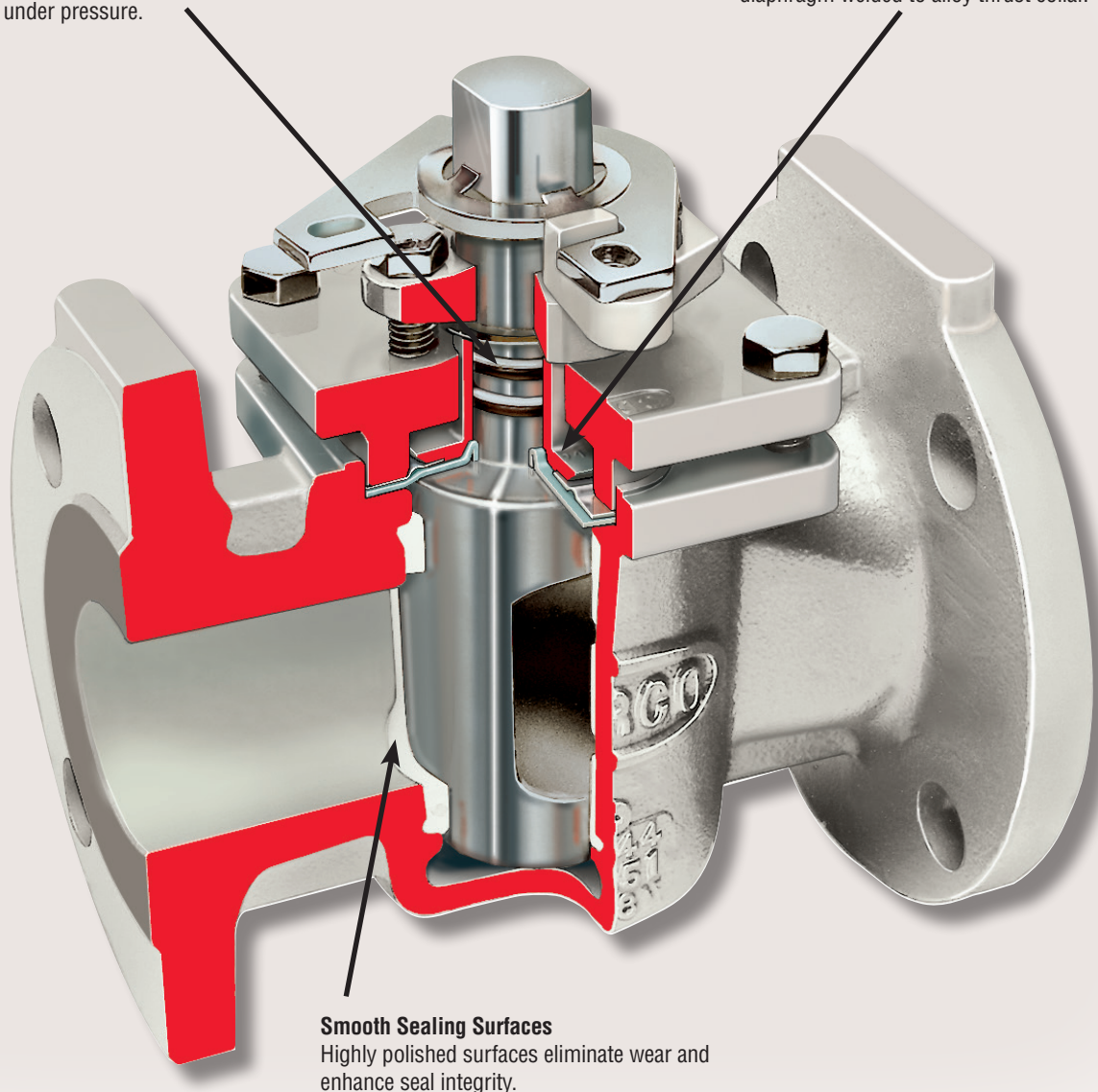

Smooth Sealing Surfaces

Highly polished surfaces eliminate wear and enhance seal integrity.

© Viton and Kalrez are registered trademarks of the DuPont Company.

© Hastelloy is a registered trademark of Haynes International.

High Cycle Positive Stem Sealing Durability

3-Year Performance Guarantee

Unprecedented limited warranty. The valve will be repaired or replaced if stem seal fails within 3 years after installation.

Unique Stem-Sealing Design

The G4B Marathon valve can be used with confidence in chemical processing applications where tight shutoff and emissions containment are priority requirements. As a bonus, its very design assures long-lived, high cycle performance.

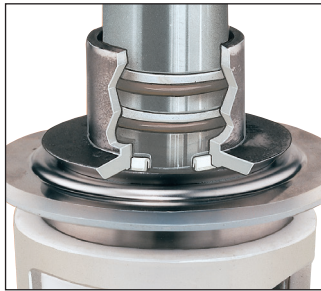

New Welded Diaphragm

The integral thrust collar/alloy diaphragm is a third line of defense against leakage to the atmosphere. The underside of the metal bellows-like diaphragm acts as an expansion joint by allowing the PFA diaphragm to adjust to plug movement and pressure changes. The Hastelloy C diaphragm provides an impermeable barrier to chlorine as well as many other services.



Available for G4Z, MG4, FJG and other models.

Viton O-Rings

A pair of Viton O-rings prevents stem leakage while containing line pressure. They also protect the thrust collar against attack from atmospheric corrosion. PTFE back-up rings firmly lock the Viton O-rings in the stem grooves and serve as anti-extrusion devices.

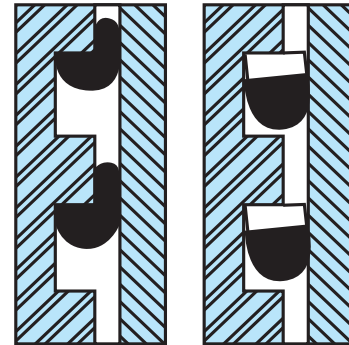

Without back-up rings

With back-up rings

Optional Kalrez O-rings are available for special services.

Proven High Cyclability

Lab and field tests have proven that the G4B Marathon can cycle as many as three-to-five times more than a standard PTFE sleeved quarter-turn valve before it begins to show stem seal wear.

Passing The Test

Lab technicians defeated the PTFE sleeve and PFA diaphragm, the G4B's primary and secondary stem seals, by cutting both of them in four places. They operated the valve to 160,000 cycles. Rather than using the standard Method 21 methane emissions test, they chose the more demanding helium emissions test. The results were impressive.

G4B Marathon Valve

Viton O-Rings and welded metal diaphragm stem seals
Sleeve and diaphragm cut in four places

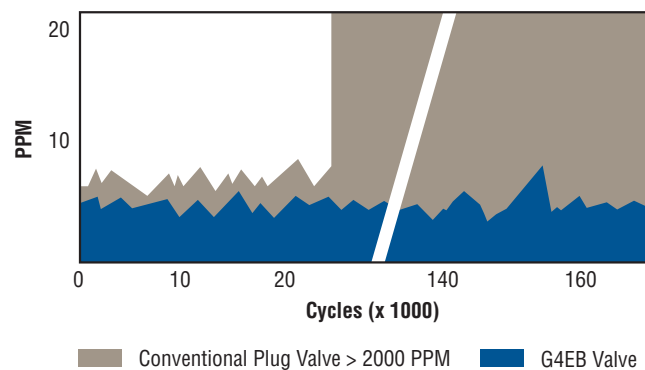

Durco TSG4 Severe Service

Triple sealed valve for lethal, toxic and sub-zero fluid services where an absolute stem seal is required. Meets/exceeds federal Clean Air Act fugitive emissions regulations at one-third to one-half the cost of bellows sealed valves.

A true stuffing box design, the TSG4 easily handles the toughest services such as chlorine, anhydrous HCl and hydrofluoric acid. It possesses all the positive shutoff, corrosion resisting features and benefits of other Durco SleeveLine valves.

Triple Sealed

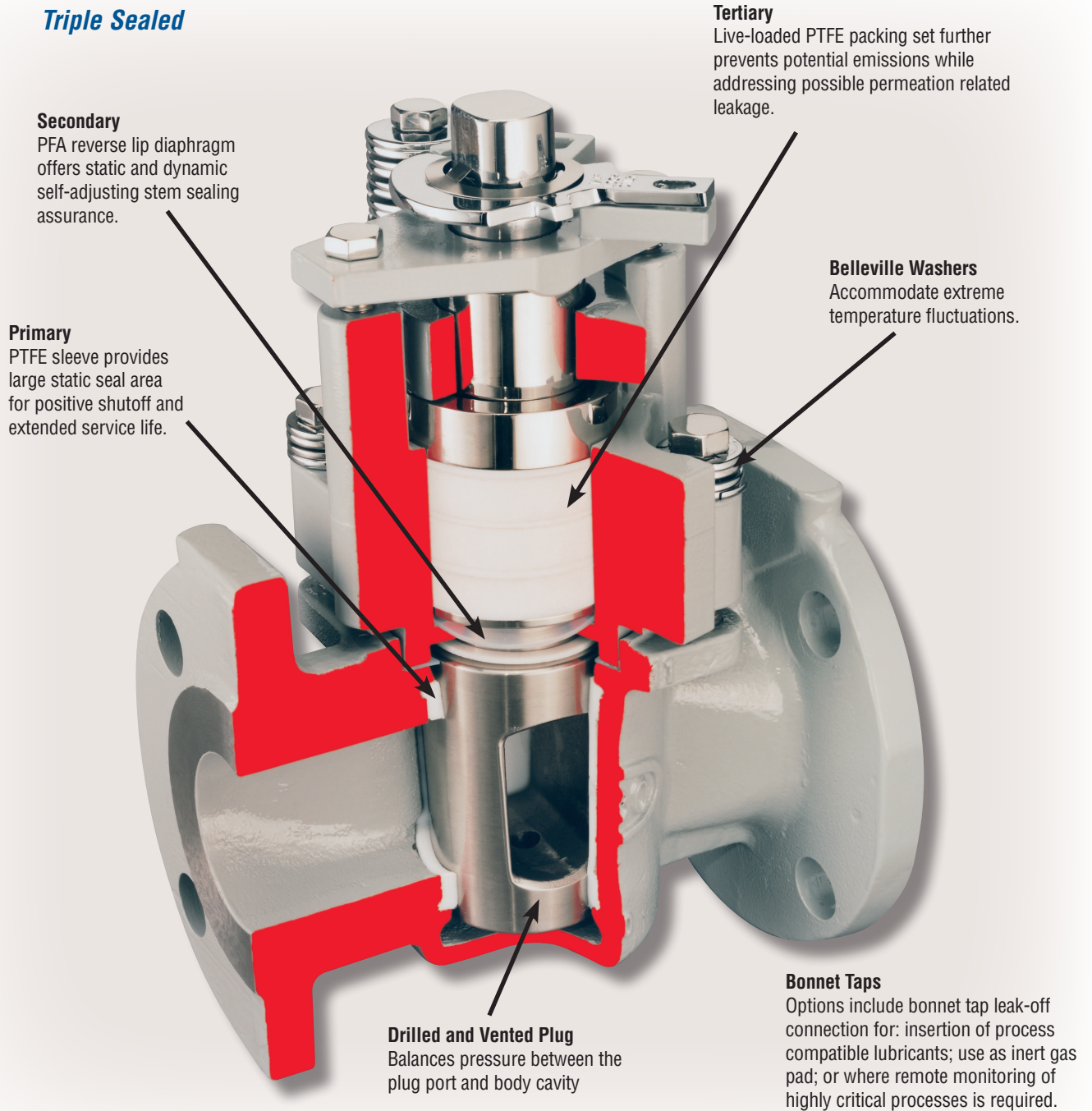

Wide Range of Stuffing Box Options with Independent Plug and Stem Seal Adjustments

The TSG4 offers broad flexibility in choosing the packing set and design options best suited to your service requirements. Choose from a variety of stem seals that lets you enjoy:

- Triple seal protection from fugitive emissions
- The sealing and long-term service benefits of the PFA reverse lip diaphragm
- Independent plug and stem sealing adjustment
- Thermal cycling capability with live-loaded fasteners using Belleville washers with PTFE packing only
- Leak-off connections for continuous monitoring

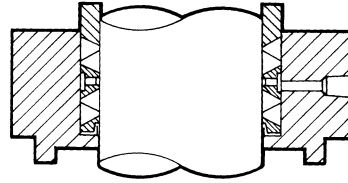

Preformed PTFE cup and cone with lantern ring and reverse lip diaphragm

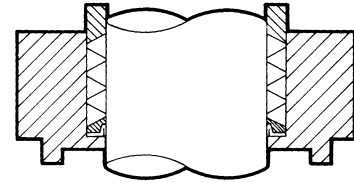

Preformed PTFE cup and cone with reverse lip diaphragm

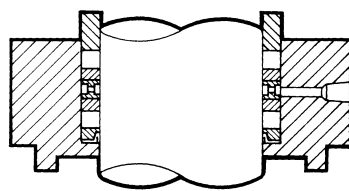

Compression fire seal packing set die formed flexible graphite rings and lantern ring between braided Grafoil® with reverse lip diaphragm

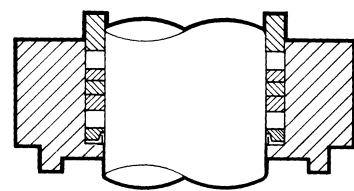

Compression fire seal packing set die formed flexible graphite rings between braided Grafoil® with reverse lip diaphragm

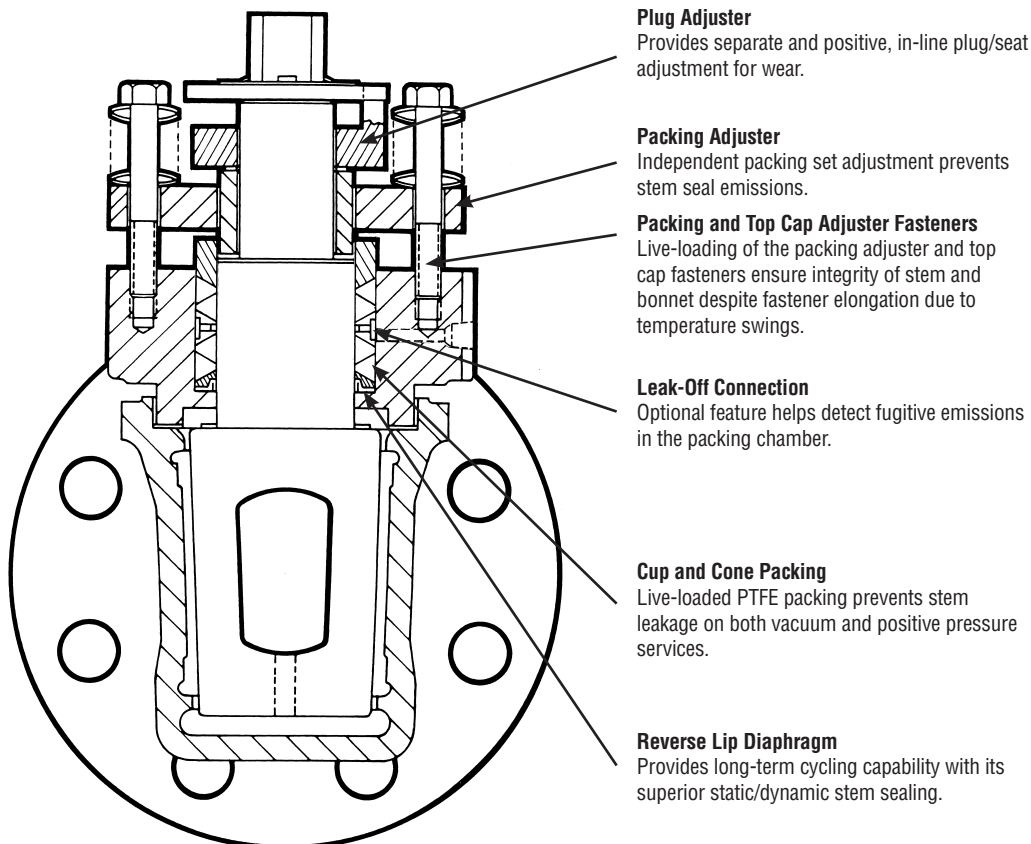

Durco G4 V-Port Control Valves

In addition to the features and benefits that have made SleeveLine the process industry's premier plug valve, Flowserve offers the G4 V-Port valve for precise modulating control services.

Durco G4 V-Port control valves are available in a variety of trim configurations to satisfy your exact flow control needs. Sizes include 1 in (25 mm) through 6 in (150 mm) with full open C_v values of 3.0 to 400.

Characterized v-port SleeveLine control valves are available as follows:

- G4 – ½ in (15 mm) through 6 in (150 mm)
- G4B – ½ in (15 mm) through 6 in (150 mm)
- TSG4 – 1 in (25 mm) through 3 in (75 mm)

A Typical Characteristic Curve for G4 V-Port Valves

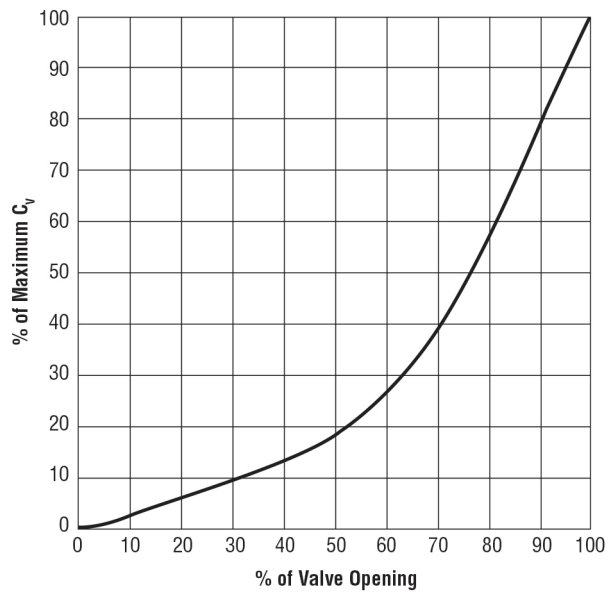

G4 V-Port C_v Values

SIZE	C_v	K_v
1"	3.0	2.6
1"	4.0	3.4
1"	8.0	6.9
1"	30	26
1.5"	31	27
2"	54	46
3"	121	104
4"	190	163
6"	400	344

Automated Systems

FLOWSERVE offers Automax, Norbro and Worcester Actuators and Instrumentation allowing us to supply complete automated on-off or modulating packages to meet exacting technical requirements.

Durco Sleevevalves are readily adaptable for automatic operation because the torque is relatively constant and lubrication is not required.

FlowsERVE, a specialist in complete automation systems, produces a broad line of rack and pinion, heavy duty, electric and linear actuators. In addition, a comprehensive line of engineered special control circuits, solenoid valves, limit switches positioners and actuator mounting kits is offered.

Our wide range of electrical and pneumatic instrumentation incorporates:

- Digital network communication
- Superior diagnostics
- Intelligent valve controllers
- Comprehensive user-friendly software
- On-line accessible automated drawing system
- Control sizing software
- Actuator sizing software

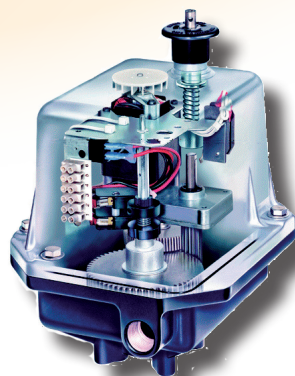
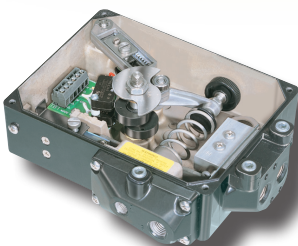

For complete tables of torque and Cv (Kv) values, please refer to the Instrument Engineers Handbook for Durco Quarter-Turn Control Valves

Special Configuration Valves

Durco valves offer the process industries' widest range of non-lubricated plug valve models, materials and configurations. This provides customers the flexibility to specify SleeveLine valves to meet virtually all their applications needs.



Chlorine Valves

Designed especially for dry chlorine gas or liquid chlorine applications. All Durco G4 chlorine valves are supplied with a plug vented on the side and bottom. This vents the chlorine safely towards the high pressure side.

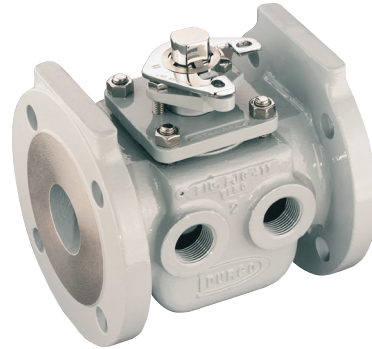

Jacketed Valves

For proven performance in critical temperature control situations, specify our FJG4 full cast jacket or the PJG4 welded partial jacket on Durco valves.



3-Way Valves

Choose Durco Multiport process valves for mixing, safety and relief, switching bypass, and transflow services. Available in fully or partially jacketed models.

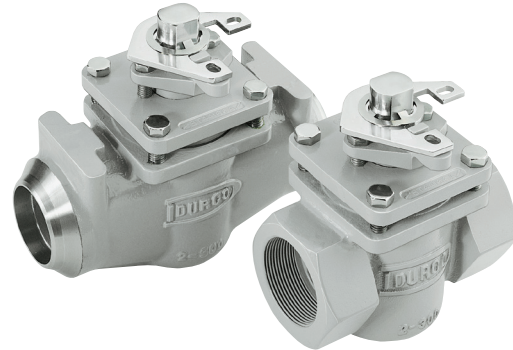

Special End Connections

In addition to ANSI and DIN flanged designs, G4 SleeveLine valves are available with grooved end; screwed end; screwed/socket end; weld end; and butt weld end connections.

Lower Torque Valves Available

For applications requiring lower torque, G4 valves (N models) in the 8 in (200 mm) thru 12 in (300 mm) sizes are available. Contact the factory for dimensional specifications.

Testing and Pressure/Temperature Ratings

G4 valves have been extensively tested to ensure the highest level of reliability possible.

The unique reverse lip stem seal has been tested from -50°F (-46°C) to 450°F (232°C) maximum, and with pressures up to 720 psig (4960 kPa).

High temperature throttling tests at 450°F (232°C) with pressure drops of 175 psig (1205 kPa) have proven the superiority of G4 valves over other soft-seated valves. Ask your Durco Valve Sales Representative for specific test results.

The valves have been temperature cycled to 450°F (232°C), and have provided performance superior to any other soft-seated valve available for cyclical temperature situations.

We believe the G4 valve is the best soft-seated valve on the market today, and will outlast and outperform all competitive valves.

Pressure-Temperature Ratings

The pressure-temperature ratings of all the materials below are based on mechanical property requirements cited in the latest ASME specifications.

The pressure-temperature rating for ductile iron is in agreement with ASME B16.42, 1998.

Valves may require adjustment to remain drop tight at the lower end of temperature range when operating below 0°F (-17°C) or during extreme temperature cycles.

G4 Pressure/Temperature Ratings

Class 150 Valves

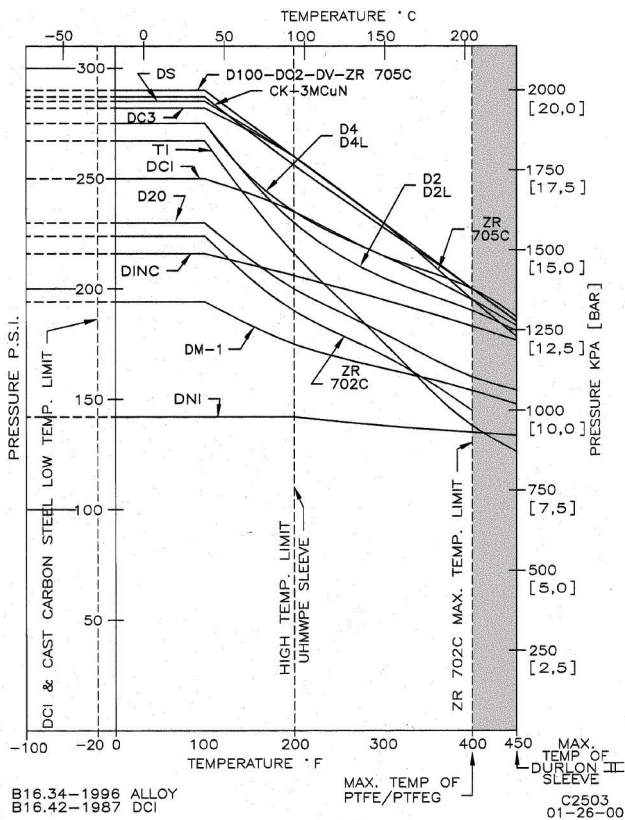

Class 300 Valves

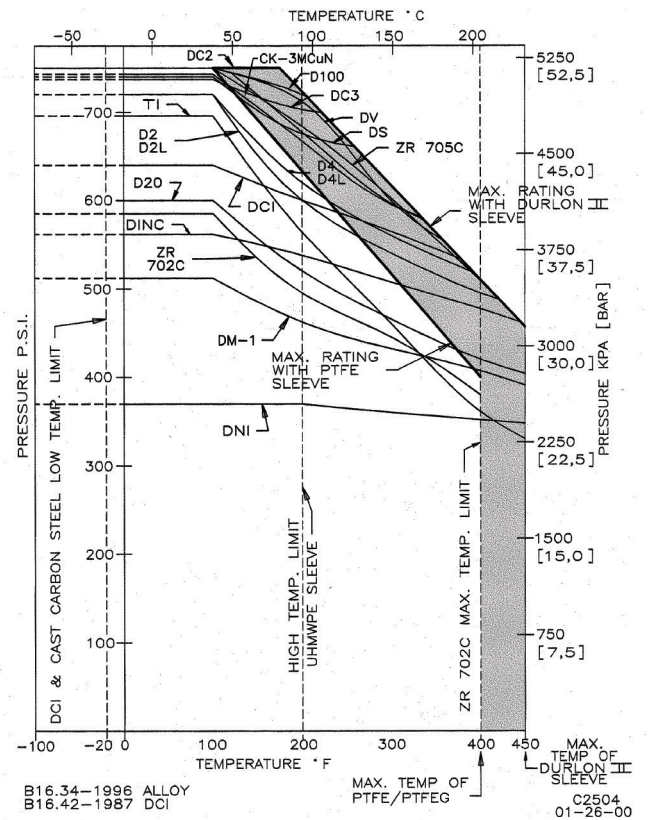

D-20 = Durimet 20 (CN-7M), CD4M = Durcomet 100 (CD-4MCu), D4 = Cast 316 SS (CF-8M), D4L = Cast 316L SS (CF-3M), D2 = Cast 304 SS (CF-8), D2L = Cast 304L SS (CF-3), DC2 = Chlorimet 2 (N-7M), DC3 = Chlorimet 3 (CW-6M), DINC = Cast Inconel (CY-40), DS = Cast Carbon Steel (WCB), DCI = Ductile Cast Iron (60-40-18), DNI = Cast Nickel (CZ-100), DM-1 = Cast Monel (M-35-1), Zr-705C = Zirconium 705C, Zr-702C = Zirconium 702C, Ti = Titanium, CK-3MCuN = 254 SMO

G4 and G4B Straightaway Valve Dimensions

English Units

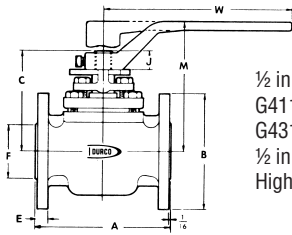

½ in (15 mm) thru 4 in (100 mm)
 G411 – Class 150
 G431 – Class 300
 ½ in (15 mm) - 3 in (75 mm) Offset Wrench Standard
 High Hub Wrench Optional

Stem Configuration
 ½ in (15 mm) to 6 in (150 mm) flats

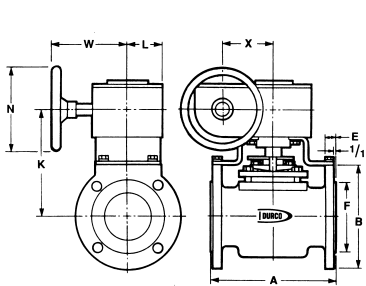

4 in (100 mm) and 6 in (150 mm)

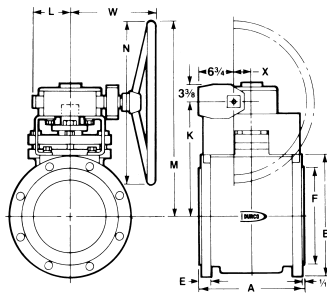

8 in (200 mm) thru 14 in (350 mm)
G411H – Class 150

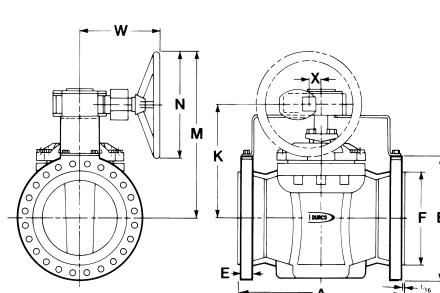

8 in (200 mm) thru 18 in (450 mm)
G431H – Class 300

Valve Size	Drilling						A		B		C	E	
	Class 150			Class 300			Class 150	Class 300	Class 150	Class 300		Class 150	Class 300
	No.	Size	BC	No.	Size	BC							
½	4	⅝	2⅜	4	⅝	2⅝	4¼	5½	3½	3⅜	3⅜	⅜	⅝
¾	4	⅝	2¾	4	¾	3¼	4⅝	6	4	4¼	3⅜	⅜	⅝
1	4	⅝	3⅜	4	¾	3½	5	6½	4¼	4⅝	3⅜	⅜	⅝
1½	4	⅝	3⅝	4	¾	4½	6½	7½	5	6⅝	4⅝	⅝	⅝
2	4	¾	4¾	8	¾	5	7	8½	6	6½	4¾	⅝	⅝
2½	4	¾	5½	8	¾	5½	7½	9½	7	7½	6	⅝	1
3	4	¾	6	8	¾	6½	8	11½	7½	8¼	6	¾	1½
4W.O.	8	¾	7½	8	¾	7½	9	12	9	10	7½	⅝	1¼
4G.O.	8	¾	7½	8	¾	7½	9	12	9	10	—	⅝	1¼
6G.O.	8	7/8	9½	12	¾	10½	10½	15½	11	12½	—	1	1½
8G.O.	8*	7/8	11¾	12	1	13	11½	16½	13½	15	—	1½	1½
10G.O.	12*	1	14¼	16	1½	15¼	13	18	16	17½	—	1½	1½
12G.O.	12*	1	17	16	1½	17¾	14	19¾	19	20½	—	1¼	2
14G.O.	12*	1½	18¾	20	1½	20¼	15	30	21	23	—	1½	2½
16G.O.	16	1½	21¼	20	1½	22½	30	33	23½	25½	—	1½	2¼
18G.O.	16	1¼	22¾	24	1½	24¾	34	36	25	28	—	1½	2½

Valve Size	F	G	H	J	K	M		N	W	X	Area of Port (in ²)	% Port Open	Weight** (lb.)	
						Class 150	Class 300						Class 150	Class 300
½	1⅜	1⅜	⅜	2⅜	—	4⅜	4⅜	—	6	—	.248	126	6½	7¾
¾	1⅜	1⅜	⅜	2⅜	—	4⅜	4⅜	—	6	—	.248	56	7	10
1	2	2⅜	2⅜	7/8	—	4⅜	4⅜	—	7	—	.785	100	10¾	17¼
1½	2⅜	2⅜	2⅜	15/16	—	5½	5½	—	9	—	1.21	68	15½	26
2	3⅜	1⅜	⅜	1	—	6⅜	6⅜	—	12	—	2.0	64	23½	29½
2½	4⅜	1⅜	⅜	1⅜	—	7½	—	—	18	—	4.6	93	38	—
3	5	1⅜	⅜	1⅜	—	7½	7½	—	18	—	4.6	65	41	69
4W.O.	6⅜	1⅜	1⅜	1⅜	—	9½	9½	—	30	—	7.4	59	75	143¾
4G.O.	6⅜	1⅜	1⅜	1⅜	8¾	19½	19½	12	8⅜	3	7.4	59	93¾	162½
6G.O.	8½	1½	1⅜	1⅜	10¾	21½	21½	12	8⅜	3	16.1	57	149¾	229½
8G.O.	10½	Splined		1¾	13¾	22½	—	18	16	⅜	26.4	52	262	328
10G.O.	12¾	Splined		2⅜	15¾	24½	—	18	16	1⅜	40.9	52	398	455
12G.O.	15	Splined		2½	16¾	25½	—	18	16	1⅜	54.7	48	519	736
14G.O.	16¼	Splined		1⅜	16¾	25½	—	18	16	1⅜	57.8	37	599	916
16G.O.	18½	Splined		3⅜	28½	40½	40½	24	18⅜	3⅜	121.0	69	1865	2097
18G.O.	21	Splined		3⅜	28½	40½	40½	24	18⅜	3⅜	121.0	54	1951	2183

Dimensions for Class 150 and 300 valves are the same except where indicated. Flanges are to ANSI B16.5 and can meet flange draft requirements. W.O. is wrench operated. G.O. is gear operated.

*The top two holes on each flange on the 8 in (200 mm), 10 in (250 mm), 12 in (300 mm) and 14 in (350 mm) G411 valves are drilled for studs.

**Weight includes wrench or operator.

All dimensions are approximate and for illustration purposes only. For exact dimensions request certified dimensional prints. See page 23 for (L) dimensions.

G4 and G4B Straightaway Valve Dimensions

Metric Units

Valve Size	Drilling						A		B		C	E	
	Class 150			Class 300			Class 150	Class 300	Class 150	Class 300		Class 150	Class 300
	No.	Size	BC	No.	Size	BC							
15	4	15	60	4	15	67	108	140	89	98	81	11	14
20	4	15	70	4	19	83	117	152	102	121	81	11	16
25	4	16	79	4	19	89	127	165	108	124	94	11	17
40	4	16	98	4	22	114	165	190	127	156	106	14	22
50	4	19	121	8	19	127	178	216	152	165	121	16	22
65	4	19	140	8	22	149	190	241	178	190	152	17	25
80	4	19	152	8	22	168	203	283	190	210	152	19	29
100	8	19	190	8	22	200	229	305	229	254	194	24	32
100	8	19	190	8	22	200	229	305	229	254	-	24	32
150	8	19	241	12	22	270	267	403	279	318	-	25	37
200	8*	19	298	12	25	330	292	419	343	381	-	29	41.3
250	12	25	362	16	29	387	330	457	406	445	-	30	47.6
300	12	29	432	16	32	450	356	502	483	521	-	32	50.8
350	12*	29	476	20	32	514	381	762	533	584	-	35	54
405	16	29	540	20	35	572	762	838	597	648	-	37	57
455	16	32	578	24	35	629	864	914	635	714	-	40	60

Valve Size	F	G	H	J	K	M		N	W	X	Area of Port (cm ²)	Weight** (kg)	
						Class 150	Class 300					Class 150	Class 300
						15	35					13.5	11.1
20	43	13.5	11.1	18.3	-	121	121	-	152	-	1.59	3.2	4.5
25	51	19.8	16.7	22.2	-	122	122	-	178	-	5.1	4.8	7.8
40	73	19.8	16.7	23.8	-	140	140	-	229	-	7.8	7.0	11.7
50	92	27.0	22.2	25.4	-	160	160	-	305	-	13.0	10.6	13.3
65	105	27.0	22.2	30.2	-	190	-	-	457	-	30.0	17.1	-
80	127	27.0	22.2	30.2	-	190	190	-	457	-	30.0	18.4	31.0
100	157	42.9	36.1	39.7	-	229	229	-	762	-	48.0	33.8	64.7
100	157	42.9	36.1	39.7	213.0	495.0	495	305	224	76	48.0	42.5	73.7
150	216	47.6	36.1	41.3	263.0	546.0	546	305	224	76	104.0	67.9	104.1
200	270	Splined		43.7	333.5	563.4	-	457	406	8	170.0	119.0	148.8
250	324	Splined		69.0	388.9	614.5	-	457	406	33	264.0	180.0	206.4
300	381	Splined		73.3	407.9	636.5	-	457	406	33	353.0	235.0	333.9
350	413	Splined		42.9	421.0	649.0	649	457	406	33	373.0	269.5	412.2
405	470	Splined		101	714.0	1019.0	1019	610	459	84	781.0	846.0	951.2
455	533	Splined		101	714.0	1019.0	1019	610	459	84	781.0	885.0	990.2

Dimensions for Class 150 and 300 valves are the same except where indicated. Flanges are to ANSI B16.5 and can meet flange draft requirements. W.O. is wrench operated. G.O. is gear operated.

*The top two holes on each flange on the 8 in (200 mm), 10 in (250 mm), 12 in (300 mm) and 14 in (350 mm) G411 valves are drilled for studs.

**Weight includes wrench or operator.

All dimensions are approximate and for illustration purposes only. For exact dimensions request certified dimensional prints. See page 23 for (L) dimensions.

Flow Indication for MG4 and MG4B 3-Way Valves

Durco three-way valve body runs are marked with letter designations "A", "B", and "C". A position indicator plate (marked with flow designations A→B, B→C, A→C, A→B→C, or CLOSED) is mounted on the top-cap. The stop collar pointer indicates the flow arrangement. The top of the plug is marked with a groove to further indicate the flow arrangement. Should the stop collar be removed, care should be taken to assure proper orientation upon reassembly.

The valve wrench is designed to operate in any of four quadrants.

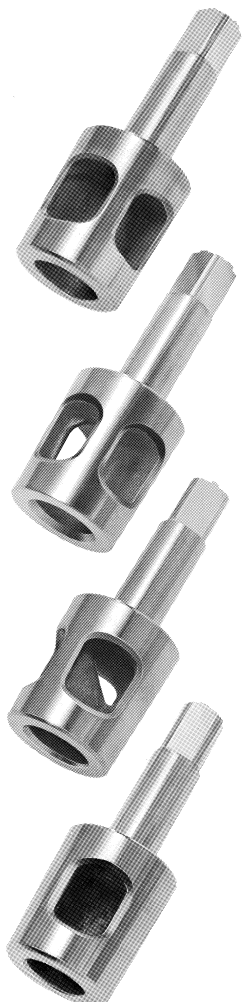

Arrangement 1

Arrangement 3 and 7

Arrangement 5 and 8

Arrangement 13

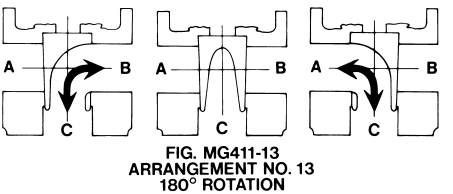
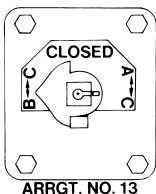
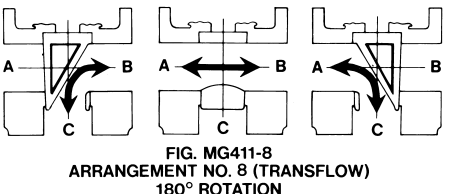
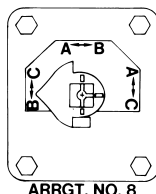
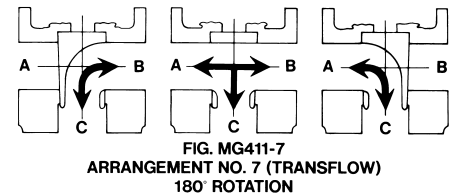
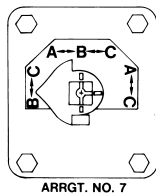
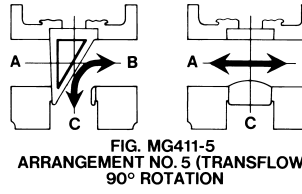
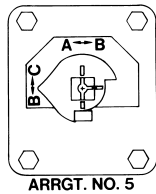
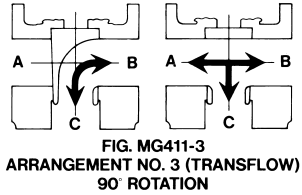
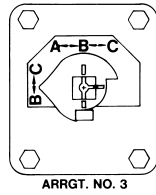
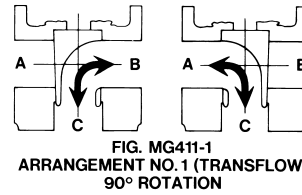
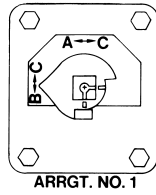

MG4 and MG4B 3-Way Valve Dimensions

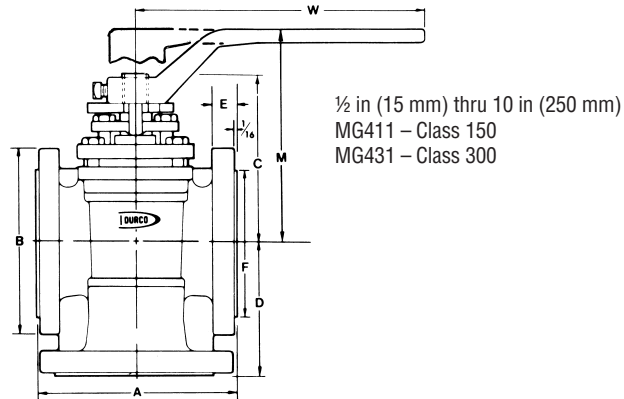

English Units

Valve Size	A		B		C	D		E		F	M	W
	Class 150	Class 300	Class 150	Class 300		Class 150	Class 300	Class 150	Class 300			
1/2	4 1/4	5 1/2	3 3/8	3 3/4	3 3/16	2 3/4	2 7/8	7/16	9/16	1 1/8	4 5/16	6
3/4	4 3/4	6	4	4 3/4	3 3/16	3	3	7/16	5/8	1 1/16	4 5/16	6
1	5	6 1/2	4 1/4	4 7/8	3 33/64	3 1/2	3 3/4	7/16	1 1/16	2	4 19/16	7
1 1/2	6 1/2	7 1/2	5	6 1/8	4 5/16	4 1/8	4 3/8	9/16	1 3/16	2 1/8	5 1/2	9
2	7	8 1/2	6	6 1/2	4 3/4	4 1/2	4 3/4	5/8	7/8	3 3/8	6 3/16	12
3	8	11 1/2	7 1/2	8 1/4	6	5 1/8	5 5/16	3/4	1 1/8	5	7 1/2	18
4	9	12	9	10	7 7/32	6	6 3/4	1 1/16	1 1/4	6 3/16	18 3/8	30
6	10 1/2	15 1/8	11	12 1/2	—	7 1/2	8 1/2	1	1 1/16	8 1/2	—	—
8	11 1/2	16 1/2	13 1/2	15	—	9	10	1 1/4	1 1/8	10 3/8	—	—
10	13	18	16	17 1/2	—	12 1/4	12 1/4	1 3/8	1 7/8	12 3/4	—	—

Metric Units

Valve Size	A		B		C	D		E		F	M	W
	Class 150	Class 300	Class 150	Class 300		Class 150	Class 300	Class 150	Class 300			
15	108	140	92	98	81	76	76	11	14	32	121	152
20	117	152	102	121	81	76	76	11	16	43	121	152
25	127	165	108	124	94	89	95	11	17	51	122	178
40	165	190	127	156	106	105	111	14	21	73	140	229
50	178	216	152	165	121	114	121	16	22	92	160	305
80	203	283	190	210	152	130	141	19	29	127	190	457
100	229	305	229	254	194	152	171	24	32	157	229	762
150	267	403	289	318	—	190	216	25	37	216	—	—
200	292	419	343	381	—	229	254	29	41	270	—	—
250	330	457	406	444	—	311	311	30	48	324	—	—

Dimensions of gears and gear mountings are the same as for straightway valves, with the exception of 8 in (200 mm), 180° 3-way valves. For stem dimensions consult factory.

All dimensions are approximate and for illustration purposes only. For exact dimensions request certified dimensional prints.

TSG4 Sleeve Valve Dimensions

English Units

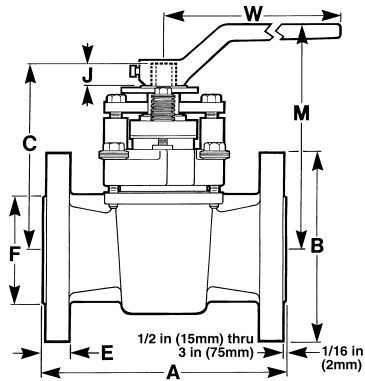

1/2 in (15 mm) thru 3 in (75 mm)
 G411 – Class 150
 G431 – Class 300
 1/2 in (15 mm) – 3 in (75 mm) Offset Wrench Standard
 High Hub Wrench Optional

Stem Configuration
 1/2 in (15 mm) to 6 in (150 mm) flats

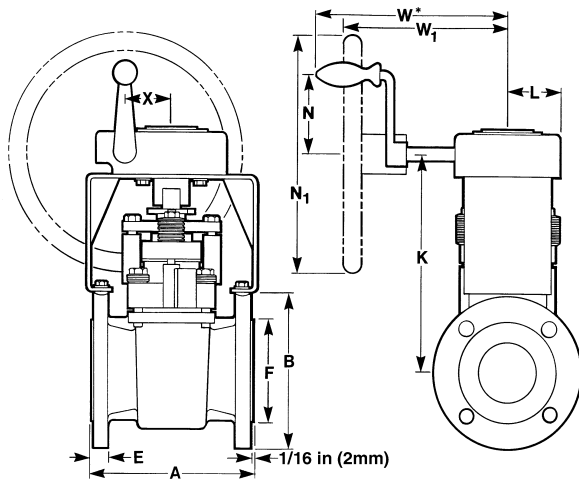

1 in (25 mm) thru 6 in (150 mm)
 G411H – Class 150

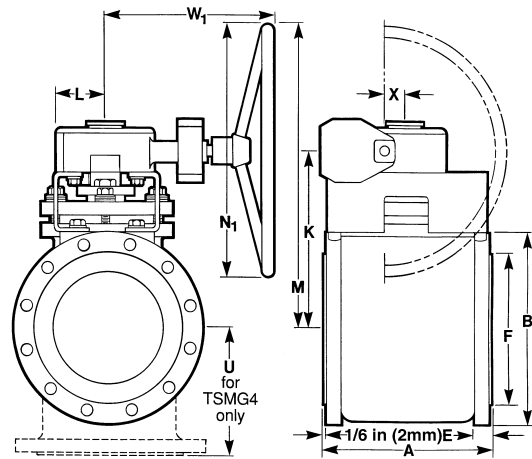

8 in (200 mm)
 G431H – Class 300

Valve Size	Drilling						A		B		C	E		F	G	H
	Class 150			Class 300			Class 150	Class 300	Class 150	Class 300		Class 150	Class 300			
	No.	Size	BC	No.	Size	BC										
1/2	4	3/8	2 3/8	4	3/8	2 3/8	4 1/4	5 1/2	3 1/2	3 3/8	6 1 1/2	7/16	9/16	1 3/8	1 1/2	3/16
3/4	4	1/2	2 3/4	4	3/4	3 1/4	4 5/8	6	3 3/8	4 3/4	6 1 1/2	7/16	5/8	1 1 1/16	1 1/2	3/16
1	4	5/8	3 1/4	4	3/4	3 1/2	5	6 1/2	4 1/4	4 7/8	6 1 1/2	7/16	1 1/16	2	2 5/8	2 1/2
1 1/2	4	3/4	3 3/4	4	7/8	4 1/2	6 1/2	7 1/2	5	6 1/8	7 1/4	9/16	1 3/16	2 7/8	2 5/8	2 1/2
2	4	3/4	4 3/4	8	3/4	5	7	8 1/2	6	6 1/2	7 5/8	5/8	7/8	3 3/8	1 1/16	7/8
3	4	3/4	6	8	7/8	6 5/8	8	11 1/8	7 1/2	8 1/4	8 3/2	3/4	1 1/8	5	1 1/16	7/8
4G.O.	8	3/4	7 1/2	8	7/8	7 7/8	9	12	9	10	10 7/2	1 5/16	1 1/4	6 3/16	1 1/16	1 2 3/4
6G.O.	8	7/8	9 1/2	12	7/8	10 3/8	10 1/2	15 1/8	11	12 1/2	12 1 1/16	1	1 1/16	8 1/2	1 1/8	1 2 3/4
8G.O.	8	7/8	11 3/4	12	1	13	11 1/2	16 1/2	13 1/2	15	17 3/2	1 1/8	1 1/8	10 3/8	Splined	

Valve Size	J	K	L	M	N	N1	U		W	W*	W1	X	Area of Port (in ²)	% Port Open	Weight	
							Class 150	Class 300							Class 150	Class 300
1/2	3/8	—	—	7 1/2	—	—	2 3/4	2 1/8	7	—	—	—	.248	126	12.0	13.75
3/4	3/8	—	—	7 1/2	—	—	2 1/2	3	7	—	—	—	.248	56	13.0	15.8
1	1 1/16	8 1/16	2 1/2	8	4 3/16	—	3 1/2	3 3/4	9	8 1 3/16	—	1 2 1/2	.785	100	27.9	32.2
1 1/2	3/4	9	2 1/2	8 3/8	4 3/8	—	4 1/8	4 3/8	9	8 1 3/16	—	1 2 1/2	1.21	68	33.1	39.1
2	1 3/16	9 1/2	2 1/2	9 3/8	4 3/8	—	4 1/2	4 3/4	12	8 1 3/16	—	1 2 1/2	2.0	64	42.8	47.5
3	1	10 3/8	2 1/2	10 1/2	4 3/8	—	5 1/8	5 3/8	20	9 1 3/16	—	2 3/8	4.6	65	69.6	83.2
4G.O.	1 3/8	11 1/8	3 1/8	19 1/2	—	12	6	6 3/4	—	—	8 1 3/16	3	7.4	59	119.1	145.6
6G.O.	1 1/8	15 3/8	3 1/2	21 1/2	—	14	7 1/2	8 1/2	—	—	9 3/8	3 3/8	16.1	57	206.8	268.9
8G.O.	1 5/8	17 1/4	4	26 1/4	—	18	9	10	—	—	15 1 3/16	3 3/8	26.4	52	262.0	328.0

All dimensions are approximate and for illustration purposes only.
 For exact dimensions request certified dimensional prints. See page 23 for (L) dimensions.

TSG4 Sleeveless Valve Dimensions

Metric Units

Valve Size	Drilling						A		B		C	E		F	G	H
	Class 150			Class 300			Class 150	Class 300	Class 150	Class 300		Class 150	Class 300			
	No.	Size	BC	No.	Size	BC										
15	4	16	60	4	16	67	108	140	89	98	161	11	14	35	13.5	11.1
20	4	16	70	4	19	83	117	152	98	121	161	11	16	43	13.5	11.1
25	4	16	79	4	19	89	127	165	108	124	176	11	17	51	19.8	16.7
40	4	16	98	4	22	114	165	190	127	156	184	14	21	73	19.8	16.7
50	4	19	121	8	19	127	178	216	152	165	194	16	22	92	27.0	22.2
80	4	19	152	8	22	168	203	283	190	210	228	19	29	127	27.0	22.2
100	8	19	190	8	22	200	229	305	229	254	275	24	32	157	42.9	36.1
150	8	22	241	12	22	270	267	403	279	318	322	25	37	216	47.6	36.1
200	8	22	298	12	25	330	292	419	343	381	436	29	41	270	Splined	

Valve Size	J	K	L	M	N	N1	U		W	W*	W1	X	Area of Port (in ²)	% Port Open	Weight	
							Class 150	Class 300							Class 150	Class 300
15	16	-	-	191	-	-	70	73	178	-	-	-	1.59	126	5.4	6.2
20	16	-	-	191	-	-	73	80	178	-	-	-	1.59	56	5.9	7.2
25	17	221	61.1	203	116	-	89	95	229	224	-	47	5.1	100	12.6	14.6
40	19	229	61.1	211	116	-	105	111	229	224	-	47	7.8	68	15.0	17.7
50	22	241	61.1	237	116	-	108	121	310	224	-	47	13.0	64	19.4	21.5
80	25	276	68.2	267	116	-	130	141	508	249	-	60	30.0	65	31.6	37.7
100	35	294	87.3	495	-	305	150	171	-	-	224	76	48.0	59	54.0	66.0
150	37	391	88.9	546	-	356	190	216	-	-	245	86	104.0	57	93.8	121.9
200	44	438	101.6	667	-	457	229	250	-	-	405	8	170.0	52	118.8	148.8

All dimensions are approximate and for illustration purposes only.

For exact dimensions request certified dimensional prints. See page 23 for (L) dimensions.

PJG4 & PJG4B Jacketed Valve Dimensions

Partially Jacketed Valves*

1 in (25 mm) thru 12 in (300 mm)

PJG411 – Class 150

PJG431 – Class 300

All dimensions are approximate and for illustration purposes only. For exact dimensions request certified dimensional prints.

*For remainder of valve dimensions, refer to straightway valve dimensions, page 12. The 4 in (100 mm) and larger sizes are gear operated.

English Units

Valve Size	X	Y	Number of Connections
1	½	2 ¹⁵ / ₁₆	3
1½	¾	2¾	3
2	¾	2 ¹⁵ / ₁₆	3
3	1¼	3¼	3
4	2¼	3¾	3
6	3	4¼	3
8	4½	5¾	3
10	6	6¾	3

Metric Units

Valve Size	X	Y
25	13	75
40	14	70
50	19	75
80	31	82
100	57	95
150	76	108
200	208	146
250	152	171

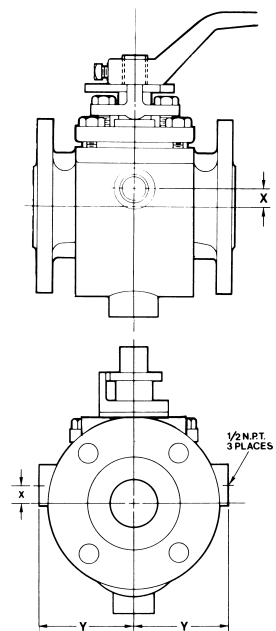

Stem Configuration
½ in (15 mm) to 6 in (150 mm) flats



FJG4 & FJG4B Jacketed Valve Dimensions

Fully Jacketed Valves*

1 in (25 mm) thru 6 in (150 mm)
 FJG411 – Class 150
 FJG431 – Class 300

All valves furnished with 1/16 in (2 mm) R.F. flanges to ASME (ASA) B 16.5 Std.
 The jacket is designed for 150 psi saturated steam.

Jackets are same material as body.

* Gear operated—for additional dimensions call factory.

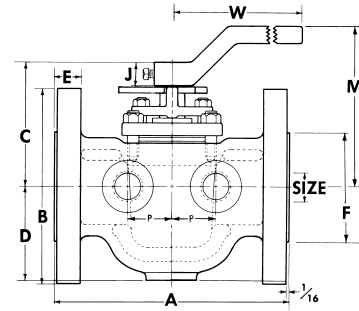

Stem Configuration
 1/2 in (15 mm) to 6 in (150 mm) flats



English Units

Valve Size	Nom. Flange Size	Drilling						A		B		C	D
		Class 150			Class 300			Class 150	Class 300	Class 150	Class 300		
		No.	Size	BC	No.	Size	BC						
1	2	4	3/4	4 3/4	8	3/4	5	7	7 7/8	6	6 1/2	3 23/32	2 3/4
1 1/2	2 1/2	4	3/4	5 1/2	8	7/8	5 5/8	7 1/2	8 1/4	7	7 1/2	4 7/32	3
2	3	4	3/4	6	8	7/8	6 7/8	8	8 7/8	7 1/2	8 1/4	4 3/4	3 1/2
3	4	8	3/4	7 1/2	8	7/8	7 1/8	9	9 3/4	9	10	6	4 1/4
4	6	8	7/8	9 1/2	12	7/8	10 3/8	10 1/2	11 1/2	11	12 1/2	7 21/32	5 5/16
6	8	8	7/8	11 3/4	12	1	13	11 1/2	12 3/4	13 1/2	15	*	6 1/16

Valve Size	E		F	G	H	J	M	P	W	Number of Connections	Jacket Connection NPT	Weight (lb.)	
	Class 150	Class 300										Class 150	Class 300
1	3/16	7/8	3 3/8	2 5/32	2 1/32	7/8	4 1/16	1 1/16	7	5	3/4	28	48
1 1/2	5/8	1	4 1/4	2 9/32	2 1/32	1 1/16	5 1/2	1 3/8	9	5	3/4	41	67
2	1 1/16	1 1/8	5	1 1/16	7/8	1	6 3/16	1 3/8	12	5	1	50	71
3	3/8	1 1/4	6 3/16	1 1/16	7/8	1 3/16	7 1/2	1 3/4	18	5	1	84	131
4	1 5/16	1 7/16	8 1/2	1 1/16	1 27/64	1 1/16	9 1/32	2	30	5	1 1/4	175	291
6	1 1/16	1 3/8	10 3/8	1 1/8	1 27/64	1 3/16	*	2 1/2	*	5	1 1/4	302	437

Metric Units

Valve Size	Nom. Flange Size	Drilling						A		B		C
		Class 150			Class 300			Class 150	Class 300	Class 150	Class 300	
		No.	Size	BC	No.	Size	BC					
25	50	4	19	121	8	19	127	178	194	154	165	94
40	65	4	19	140	8	22	149	190	210	178	190	106
50	80	4	19	152	8	22	168	203	225	190	210	121
80	100	8	19	190	8	22	200	229	248	229	254	273
100	150	8	22	241	12	22	270	267	292	279	318	194
150	200	8	22	298	12	25	330	292	321	343	381	*

Valve Size	D	E		F	G	H	J	M	P	W	Weight (kg)	
		Class 150	Class 300								Class 150	Class 300
25	70	14	22	92	20	17	22	122	33	178	12.6	21.6
40	76	16	25	105	20	17	24	140	35	229	18.4	30.2
50	89	17	29	127	27	22	25	160	35	305	22.5	32.0
80	108	19	32	157	27	22	30	190	44	457	37.8	59.0
100	132	24	37	216	43	36	40	229	50	762	78.8	131.0
150	164	27	41	270	48	36	40	*	64	*	135.9	196.7

G4 & G4B Screwed End Valve Dimensions

Straightway Screwed End Valves

¼ in (5 mm) thru 2 in (50 mm)
 G432 Class 150 & 300
 ¼ in (5 mm) - ¾ in (20 mm)
 High Hub Wrench Standard

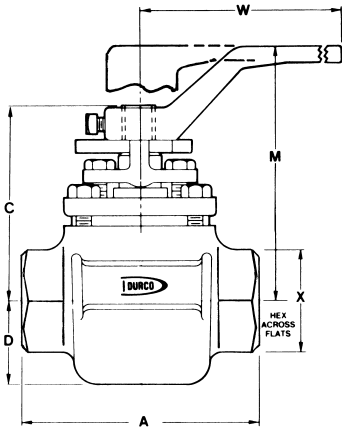

English Units

Valve Size	A	C	D	M	W	X	Area of Port (in ²)	% Port Opening Based on Nominal Size	Weight (lb.)
¼	3½	3⅜	1½	4⅝	6	1⅞	.248	506	4
⅜	3½	3⅜	1½	4⅝	6	1⅞	.248	225	3¾
½	3½	3⅜	1½	4⅝	6	1⅞	.248	126	3¾
¾	3½	3⅜	1½	4⅝	6	1⅞	.248	56	3½
1	4¾	3⅝	1½	4⅞	7	1⅞	.785	100	7
1½	5½	4⅝	1⅞	5½	9	2⅞	1.21	68	9¼
2	6	4¾	2½	6⅞	12	3⅞	2.0	64	15¾

Metric Units

Valve Size	A	C	D	M	W	X	Area of Port (cm ²)	Weight (kg)
5	89	81	34	121	152	40	1.59	1.8
10	89	81	34	121	152	40	1.59	1.7
15	89	81	34	121	152	40	1.59	1.7
20	89	81	34	121	152	40	1.59	1.6
25	117	94	40	122	178	49	5.1	3.2
40	140	106	48	140	229	65	7.8	4.2
50	152	121	56	160	305	79	13.0	7.1

3-Way Screwed End Valves

½ in (15 mm) thru 2 in (50 mm)
 MG432 Class 150 & 300
 ¼ in (5 mm) - ¾ in (20 mm)
 High Hub Wrench Standard

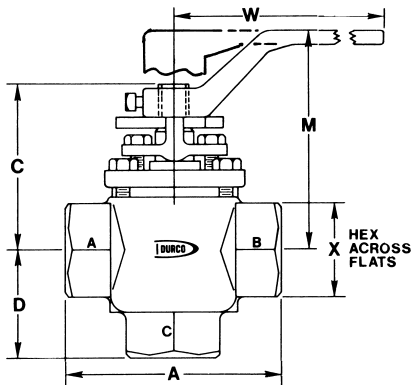

English Units

Valve Size	A	C	D	Wrench Sq. Dim.	M	W	X	Weight (lb.)
¼	3½	3⅜	1¾	⅞	4⅝	6	1⅞	4¾
⅜	3½	3⅜	1¾	⅞	4⅝	6	1⅞	4½
½	3½	3⅜	1½	⅞	4⅝	6	1⅞	4½
¾	3½	3⅜	1¾	⅞	4⅝	6	1⅞	4¼
1	4¾	2⅝	2¾	2⅝	4⅞	7	1⅞	10½
1½	5½	4⅝	2⅞	2⅝	5½	9	2⅞	17½
2	6	4¾	3⅞	⅞	6⅞	12	3⅞	22½

Metric Units

Valve Size	A	C	D	Wrench Sq. Dim.	M	W	X	Weight (kg)
5	89	81	44	11	121	152	40	2.2
10	89	81	44	11	121	152	40	2
15	89	81	44	14	121	152	40	2
20	89	81	44	14	121	152	40	1.9
25	117	69	60	14	122	178	49	4.7
40	140	106	73	14	140	229	65	7.9
50	152	121	86	22	160	305	79	10.1

All dimensions are approximate and for illustration purposes only. For exact dimensions request certified dimensional prints.

G4 & G4B Weld End Valve Dimensions

Socket Weld Valves

ASME B16.11

These valves can be welded without disassembly of the valve. Consult IOM-240, available from Flowserve Corporation, for welding procedures and precautions. Welding of ductile iron is not recommended.

¼ in (5 mm) thru 2 in (50 mm)
 G434 Class 150 & 300
 ¼ in (5 mm) - ¾ in (20 mm)
 High Hub Wrench Standard

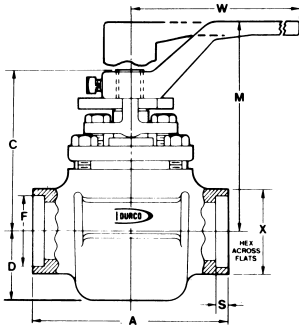

English Units

Valve Size	A	C	D	F	M	S	W	X	Area of Port (in ²)	% Port Opening Based on Nominal Size	Weight (lb.)
¼	3½	3⅜	1½	—	4 ² / ₃₂	—	6	1⅞	.248	506	2
⅜	3½	3⅜	1½	—	4 ² / ₃₂	—	6	1⅞	.248	225	2
½	3½	3⅜	1½	.86	4 ² / ₃₂	¾	6	1⅞	.248	126	2
¾	3½	3⅜	1½	1.07	4 ² / ₃₂	½	6	1⅞	.248	56	2¾
1	4½	3 ³ / ₃₂	1 ¹ / ₃₂	1.33	4 ¹ / ₁₆	½	7	1⅞	.785	100	7
1½	5½	4 ¹ / ₃₂	1½	1.91	5½	½	9	2⅞	1.21	68	9¼
2	6	4¾	2½	2.40	6⅞	¾	12	3⅞	2.0	64	15¾

Metric Units

Valve Size	A	C	D	F	M	S	W	X	Area of Port (cm ²)	Weight (kg)
5	89	81	34	—	121	—	152	40	1.597	0.9
10	89	81	34	—	121	—	152	40	1.597	0.9
15	89	81	34	22.0	121	10	152	40	1.597	0.9
20	89	81	34	27.0	121	13	152	40	1.59	1.2
25	117	94	40	33.8	122	13	178	49	5.1	3.2
40	140	106	48	48.5	140	13	229	65	7.8	4.2
50	152	121	56	61.0	160	16	305	79	13.0	7.1

Note: Not available in ductile cast iron. Valves provided in D20, DC2, DC3, and DM will be furnished with stub ends pre-welded into valve.

Butt Weld Valves

These valves can be welded without disassembly of the valve. Consult IOM-240, available from Flowserve Corporation, for welding procedures and precautions. Welding of ductile iron is not recommended. 4 in (100 mm) through 12 in (300 mm) valves are normally gear operated. Butt-weld valves are machined to match schedule 40 (ASME) piping systems unless otherwise specified.

½ in (15 mm) thru 12 in (300 mm)
 G413 Class 150
 G433 Class 300

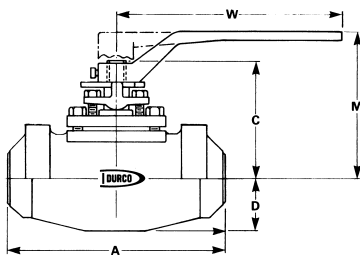

English Units

Valve Size	A		C	D	M	W	Area of Port (in ²)	% Port Opening Based on Nominal Size
	150	300						
½	6½	6½	3⅜	1½	4 ² / ₃₂	6	.248	126
¾	6½	6½	3⅜	1½	4 ² / ₃₂	6	.248	56
1	6½	6½	3 ³ / ₃₂	1 ¹ / ₃₂	4 ¹ / ₁₆	7	.785	100
1½	7½	7½	4 ¹ / ₃₂	1½	5½	9	1.21	68
2	8½	8½	4¾	2½	6⅞	12	2.0	64
3	12	12	6	2 ² / ₃₂	7½	18	4.6	65
4	14	14	7 ¹ / ₃₂	3 ¹ / ₁₆	10 ¹ / ₃₂	30	7.4	59
6	17	17	9 ² / ₃₂	4⅞	—	—	16.1	57
8	20	20	*	6⅞	—	—	27.7	55
12	26	26	*	9⅞	—	—	57.8	37

Metric Units

Valve Size	A		C	D	M	W	Area of Port (cm ²)
	150	300					
15	165	165	81	31	127	152	1.59
20	165	165	81	31	127	152	1.59
25	165	165	94	40	122	178	5.1
40	191	191	106	48	140	229	7.8
50	216	216	121	56	160	305	13.0
80	305	305	152	74	191	457	30.0
100	356	356	194	94	261	762	48.0
150	432	432	247	124	314	1168	104
200	508	508	*	163	—	—	179
300	660	660	*	233	—	—	373

Note: Not available in ductile cast iron. Valves provided in D20, DC2, DC3, and DM will be furnished with stub ends pre-welded into valve.

All dimensions are approximate and for illustration purposes only. For exact dimensions request certified dimensional prints.

Manual Actuator & Trim Options

Handwheel Extension

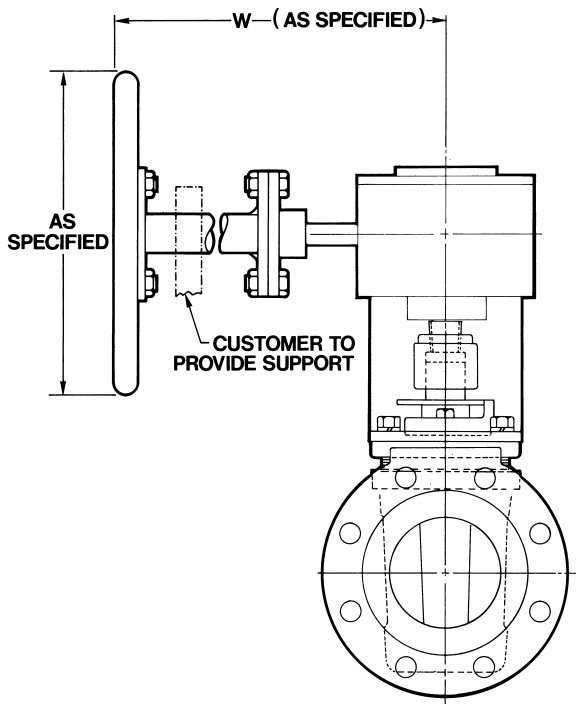

T-Handle Wrench

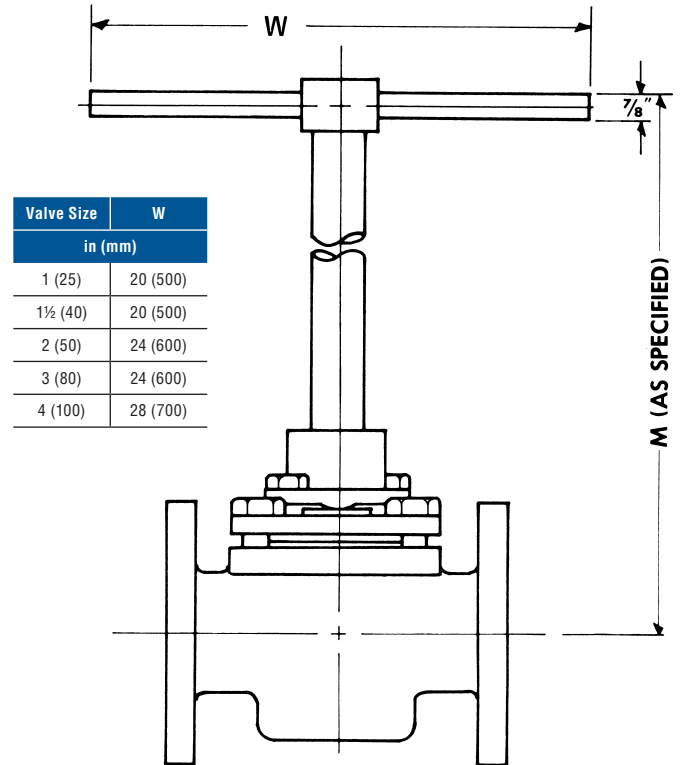

Chlorine Valve

The Durco G4 Chlorine Valve is built in accordance with the recommendations of The Chlorine Institute. This valve is manufactured with a cast carbon steel body and a vented Monel plug for dry chlorine service. It is cleaned, dried and packaged for delivery.

Vented plug design is also recommended for other cold liquids such as anhydrous HCL.

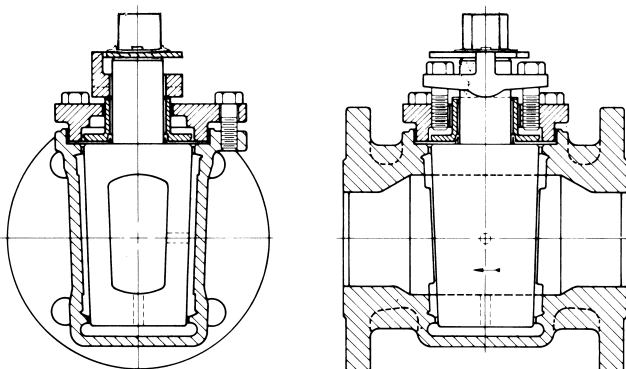

Double Block and Bleed

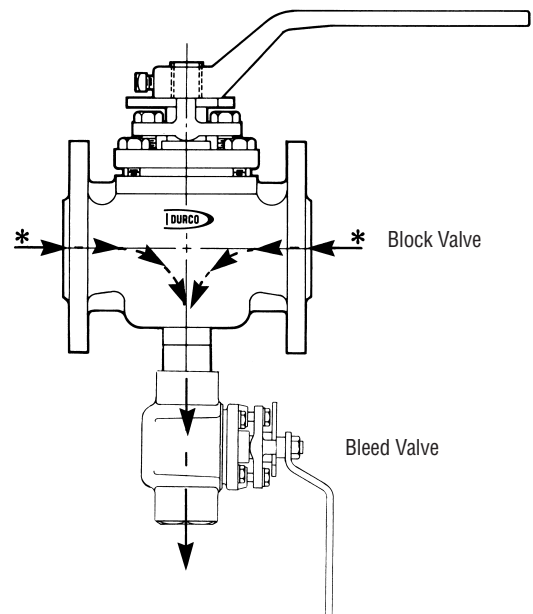

* Plug cavity and upstream or downstream bleed capability as specified by the customer. ¼ in (5 mm) bleed valve is standard—other sizes are available.

Double End Chain Wrench

NOTE: Customer must specify horizontal or vertical installation.

1 in (25 mm)
thru 3 in (75 mm)

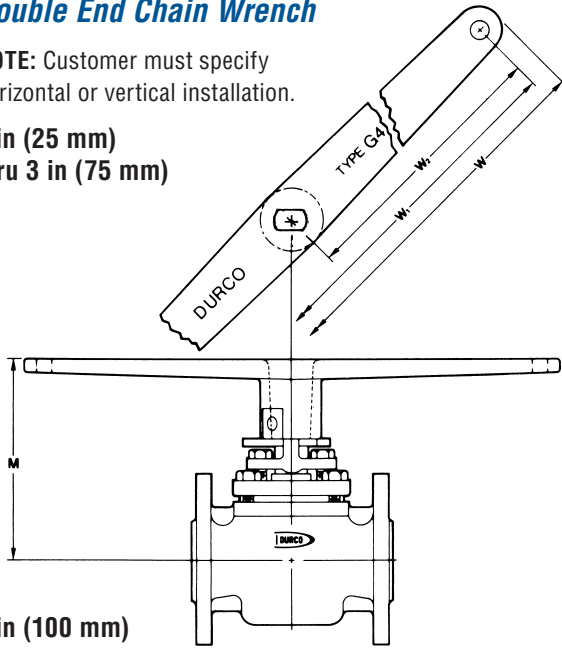

4 in (100 mm)

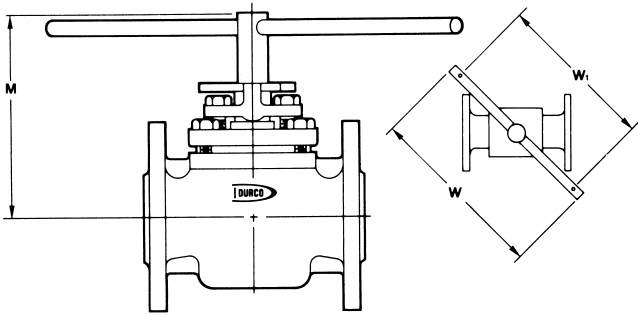

English Units

Valve Size	M	W	W ₁	W ₂
1	3 ³ / ₂	13 ¹ / ₂	12	6
1 ¹ / ₄	5 ² / ₂	13 ¹ / ₂	12	6
1 ¹ / ₂	5 ² / ₂	13 ¹ / ₂	12	6
2	5 ¹ / ₄	25	24	12
2 ¹ / ₂	6 ⁵ / ₁₆	25	24	12
3	6 ⁵ / ₁₆	25	24	12
4	9 ¹ / ₂	62	60	—

Metric Units

Valve Size	M	W	W ₁	W ₂
25	94	343	305	152
30	144	343	305	152
40	144	343	305	152
50	133	635	610	305
65	160	635	610	305
80	160	635	610	305
100	241	1575	1524	—

All dimensions are approximate and for illustration purposes only. For exact dimensions request certified dimensional prints.

Crank

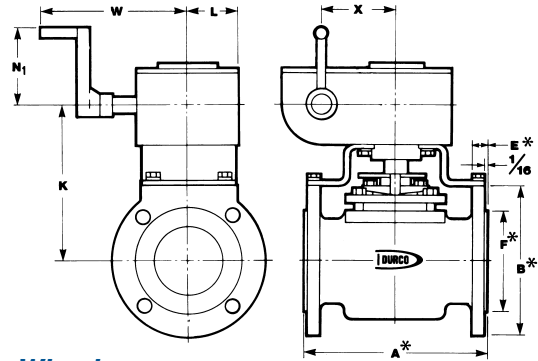

Chain Wheel

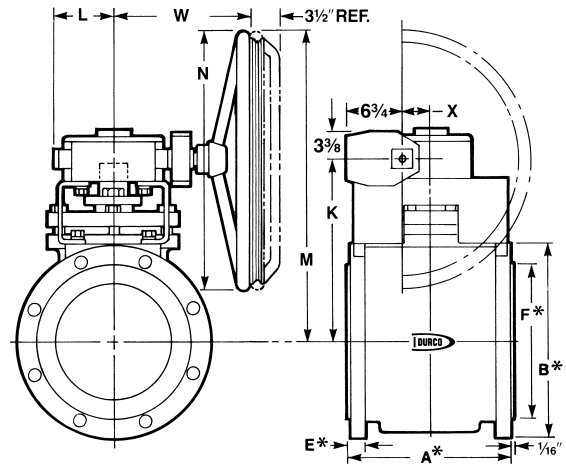

English Units

Valve Size	K	L	M	N	N ₁	W	X	Sprocket Size
1	4 ¹ / ₄	2 ³ / ₈	—	8	4 ⁹ / ₁₆	7 ⁷ / ₈	1 ¹ / ₁₆	2
1 ¹ / ₂	4 ³ / ₄	2 ³ / ₈	—	8	4 ⁹ / ₁₆	7 ⁷ / ₈	1 ¹ / ₁₆	2
2	5 ¹ / ₁₆	2 ³ / ₈	—	8	4 ⁹ / ₁₆	7 ⁷ / ₈	1 ¹ / ₁₆	2
3	6 ⁵ / ₁₆	2 ¹ / ₁₆	—	8	4 ⁹ / ₁₆	8 ⁷ / ₈	2 ³ / ₈	2
4	8 ³ / ₁₆	3 ⁷ / ₁₆	—	13	11 ¹ / ₁₆	12 ¹ / ₁₆	3	2 ¹ / ₂
6	10 ³ / ₁₆	3 ⁷ / ₁₆	—	13	11 ¹ / ₁₆	12 ¹ / ₁₆	3	2 ¹ / ₂
8	13 ¹ / ₁₆	4	22 ¹ / ₁₆	18	—	15 ¹ / ₁₆	3 ¹ / ₁₆	3 ¹ / ₂
10	14 ⁹ / ₁₆	4 ¹ / ₂	23 ⁹ / ₁₆	18	—	15 ¹ / ₁₆	1 ¹ / ₁₆	3 ¹ / ₂
12	13 ⁹ / ₁₆	4 ¹ / ₂	22 ⁹ / ₁₆	18	—	15 ¹ / ₁₆	1 ¹ / ₁₆	3 ¹ / ₂
14	16 ⁹ / ₁₆	4 ¹ / ₂	25 ⁹ / ₁₆	18	—	16	1 ¹ / ₁₆	3 ¹ / ₂
16	24 ⁹ / ₁₆	6	36 ⁹ / ₁₆	24	—	18 ¹ / ₁₆	3 ³ / ₁₆	4 ¹ / ₂
18	24 ⁹ / ₁₆	6	36 ⁹ / ₁₆	24	—	18 ¹ / ₁₆	3 ³ / ₁₆	4 ¹ / ₂

Metric Units

Valve Size	K	L	M	N	N ₁	W	X	Sprocket Size
25	108	60	—	203	116	181	46	51
40	121	60	—	203	116	181	46	51
50	129	60	—	203	116	181	46	51
75	160	68	—	203	116	207	60	51
100	213	87	—	330	283	306	76	64
150	264	87	—	330	283	306	76	64
200	333	102	562	457	—	405	8	64
250	370	114	598	457	—	405	33	89
300	344	114	573	457	—	405	33	89
350	421	114	649	457	—	406	33	89
400	618	152	922	610	—	459	84	114
450	618	152	922	610	—	459	84	114

Parts and Materials

G4 Valve

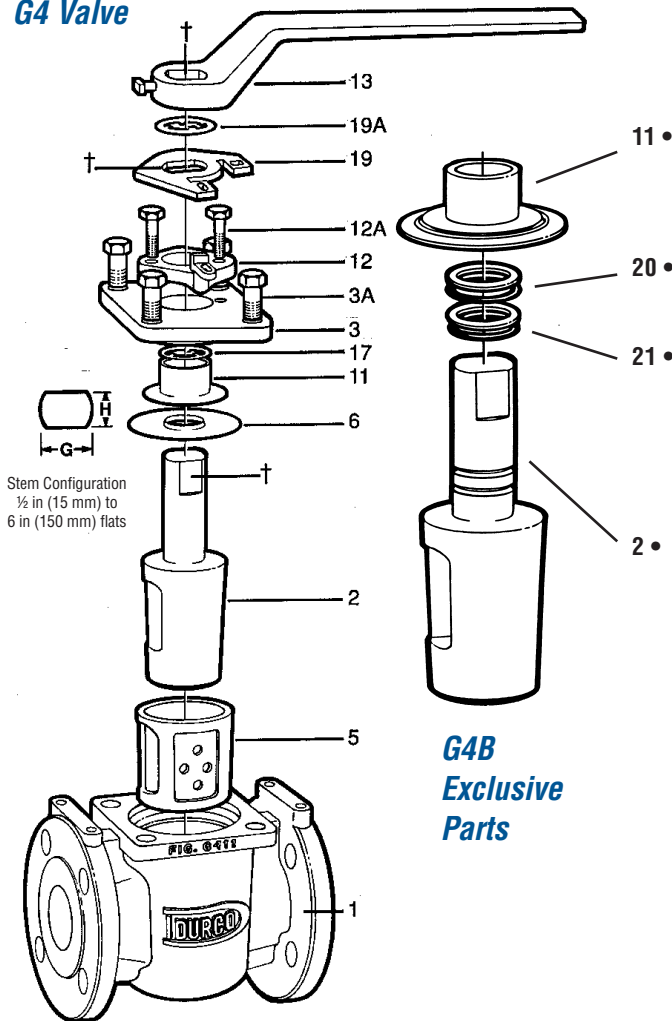

G4 & G4B

Item No.	Description	Material of Construction	No. Req.
1	Body	*	1
2	Plug	*	1
2 •	Plug	*	1
3	Top Cap	Durcomet 100**/ Ductile Iron	1
3A	Top Cap Fastener	B8M3 SS/B7 (CR-MO) Steel	4
5	Sleeve	PTFE***	1
6	Diaphragm	PFA or TM***	1
11	Thrust Collar	Durcomet 100	1
11 •	Thrust Collar/ Diaphragm	Durcomet 100/Hastelloy®	1
12	Adjuster	Durcomet 100	1
12A	Adjuster Fastener	B8-40 SS/B7 (CR-MO) Steel	2
13	Wrench	Ductile Iron	1
17	Grounding Spring	304 SS	1
19 [†]	Stop Collar	Zinc Plated Carbon Steel	1
19A	Stop Collar Retainer	302 SS	1
20 •	Back-up Ring	PTFE	2
21 •	O-ring	Viton (Kalrez optional)	2

G4B Exclusive Parts

* Body (Item No. 1) and Plug (Item No. 2) available in the following cast materials: Ductile Iron; Carbon Steel; CF-8 SS; Durcomet 100; Durimet 20; Chlorimet 2 and 3; Nickel; Monel; Inconel; Titanium and Zirconium.

** Durcomet 100 is a high alloy stainless steel, CD4M Cu.

*** Other materials available on request.

• Parts exclusive to G4B.

[†] locking stop collar is standard for valves 1/2 - 3"

Applicable Valve Standards

Specification	Title
ASME B16.10	Face-to-face dimension
ASME B16.34	Steel valves, flanged & butt weld
ASME B16.5	Flange & flange fitting
ASME B1.20.1	Screwed ends
API 607	Fire safe valve testing
API 598	Valve inspection & test
ASME B16.11	Forged fittings, socket weld and threaded
M.S.S. SP-54	Radiographic
M.S.S. SP-55	Visual quality
M.S.S. SP-61	Hydrostatic testing

Standard Materials Selection Chart A

ASTM A395 Ductile Cast Iron	ASTM A351/A744 Gr. CK-3MCuN (254 SMO) ¹
Ductile Cast Iron Nickel Plated (Plug Only)	ASTM A494 Gr. CY-40 (Inconel 600) ²
ASTM A216 Gr. WCB (Cast Steel)	ASTM A494 Gr. M35-2 (Monel 400) ²
Cast Steel Nickel Plated (Plug Only 3" or larger)	ASTM A494 Gr. M35-1 (Monel 400) ²
ASTM A351/A744 Gr. CF8 (304 S.S.)	ASTM A494 Gr. CZ-100 (Nickel 200)
ASTM A351/A744 Gr. CF3 (304L S.S.)	ASTM A494 Gr. N-7M (Chlorimet 2)
ASTM A351/A744 Gr. CF8M (316 S.S.)	STM A494 Gr. CW-6M (Chlorimet 3)
ASTM A351/A744 Gr. CF3M (316L S.S.)	ASTM B367 Gr. C-3 (Titanium)
Durcomet 5 (Durco's High Silicon S.S.)	ASTM B752 Gr. 702C (Zirconium)
ASTM A351/A744 Gr. CD4MCuN (Duplex S.S.)	ASTM B752 Gr. 705C (Zirconium)
ASTM A351/A744 Gr. CN-7M (Alloy 20)	ASTM A995 Gr. 5A (CE3MN) Super Duplex SS

1. Registered trademark of Avesta AB

2. Registered trademark of the International Nickel Company, Inc.

This list shows several of our common materials; however, any of the wide range of Flowserve materials is available.

Parts and Materials

G4Z

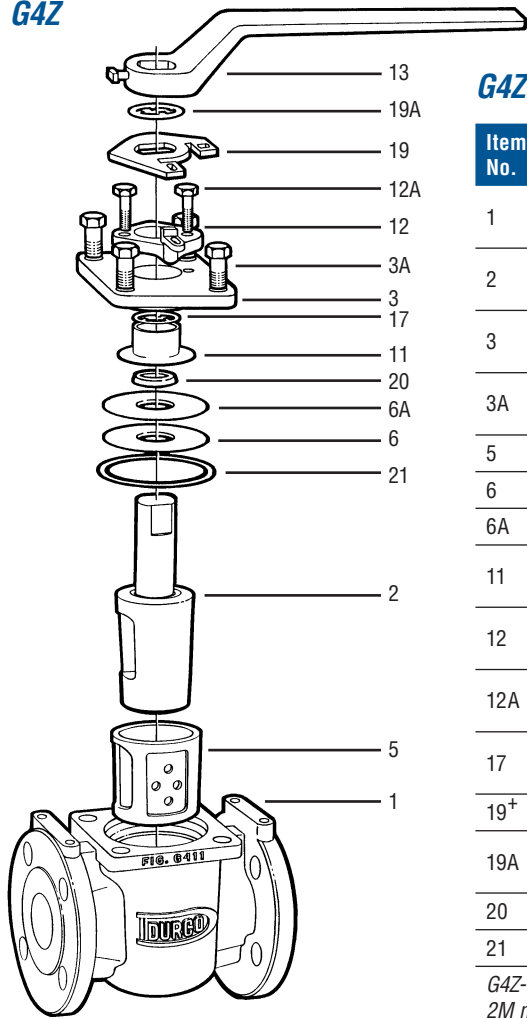

G4Z Fire Sealed

Item No.	Description	Material of Construction
1	Body	ASTM A351 A744 Gr. CF8M
2	Plug	ASTM A351A744 Gr. CF8M
3	Top Cap	ASTM A744 Gr. CD4MCu
3A	Top Cap Fasteners	B8M3 SS/B7 (CR-MO) Steel
5	Sleeve	PTFE
6	Diaphragm	PFA or TM****
6A	Diaphragm	Steel or Monel
11	Thrust Collar	ASTM A744 Gr. CD4MCu
12	Adjuster	ASTM A744 Gr. CD4MCu
12A	Adjuster Fasteners	B7M
17	Grounding Spring	302 S.S.
19 ⁺	Stop Collar	Zinc Plated Steel
19A	Stop Collar Retainer	302 SS
20	Packing	Grafoil®
21	Gasket	Grafoil®

G4Z-HF valves substitute B7M studs and 2M nuts for hex head to cap fasteners.

⁺ locking stop collar is standard for valves ½ - 3"

**** Other materials available.

TSG4 Severe Service

Item No.	Description	Material of Construction
1	Body	ALY*
2	Plug	ALY*
3•	Sleeve	TFE
4•	Packing	PTFE
5	Packing Adjuster	D100
6	Packing Gland	304SS
7	Belleville Washers	17-7 PH E.N.C.***
8	Adjuster Fasteners	B7/B8
9	Top Cap	ALY*
10	Top Cap Fasteners	B7/B8
11	Plug Adjuster	ASTMA 744 Gr. CD4MCu

Item No.	Description	Material of Construction
12	Plug Adjuster Fasteners	B7/B8
13	Stop Collar	Zinc Plated Steel
14	Belleville Washers	17-7 PH E.N.C.***
15	Stop Collar Retainer	302SS
16•	Grounding Spring	302 SS
17•	Plug Gland	304 SS
18•	Thrust Washer	Glass Filled TFE
19•	Plug Bearing	TFE
20•	Gasket - Top Cap	GY**

TSG4

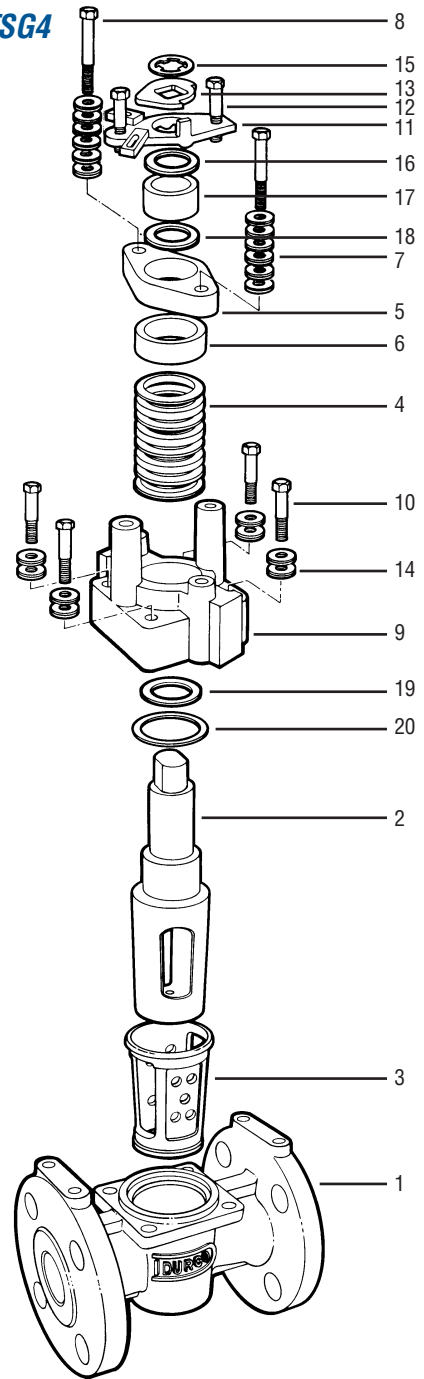

* Carbon Steel; 316SS; Durimet 20; Chlorimet 3; Monel. Plug and Top Cap are typically the same alloy unless otherwise specified.

** Part Nos. 4 & 20 are Grafoil® on Fire Sealed TSG4Z.

*** Part Nos. 7 & 14 are not normally used on Fire Sealed TSG4Z. Optional Inconel 718 recommended in corrosive environments.

• Recommended spare parts.

© Grafoil is a registered trademark of Union Carbide.

How to Specify

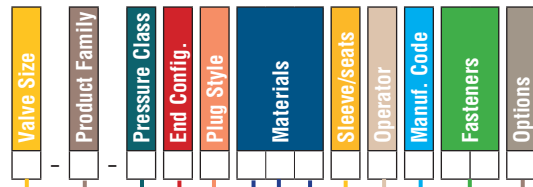

Example: 4-G4B-31C810D1M33Z
 4" Durco G4 Marathon plug valve, ASME Class 300, 2-way, carbon steel body, 316 SS plug, CD4MCuN top cap, Durlon sleeve, fasteners in B7, firesealed

Valve size	
	0.25
	0.38
	0.5
	0.75
	1
	1.5
	2
	3
	4
	5
	6
	8
	10
	12
	14
	16
	18
	20
Product Family	
2 WAY	G4
3 WAY	MG4
Marathon	G4B
HF Alkylation Valve	G4HF
Full Jacket G4	FJG4
Partial Jacket G4	PJG4
2 Way*	G4N
2 Way Acetic Acid	G4AA
Pressure Class	
150	1
PN 10	2
300	3
PN 16	4
300x600	5
600	6
PN 25	7
PN 40	8
End Configuration	
Raised Face Flange	1
Screwed End	2
Butt Weld **	3
Socket Weld	4
ButtweldXsocket weld	5
Flat Face Flange	F
Ring Type Joint	R
Small Groove Flange	S
Large Groove Flange	T
Plug Style	
2 Way	C
3 Way Arr 1	D
3 Way Arr 3	E
3 Way Arr 5	F
3 Way Arr 7	G
3 Way Arr 8	H
3 Way Arr 13	J
Cv 4 1"	K
Cv 8 1"	L
Cv 30 1"	M
Cv 31 1.5"	N
Cv 54 2"	P
Cv 12 3"	Q
Cv 188 4"	R
Cv 370 6"	S
Cv 3 1"	U
Cv 1 1"	W
Cv 171	Z

* For 8" - 12" G4N is standard
 ** Pipe stubs required on Alloy 20, Chlorimet 3, CD4MCuN, Monel, CE3MN

Body Alloy		Plug Alloy		Top Cap Alloy	
0	CD4MCuN	0	CD4MCuN	0	CD4MCuN
1	316 SS	1	316 SS	D	Ductile iron
2	Alloy 20	2	Alloy 20	L	316L SS
3	Monel	3	Monel	5	DC2
4	Nickel	4	Nickel	6	DC3
5	Chlorimet 2	5	Chlorimet 2	7	Titanium
6	Chlorimet 3	6	Chlorimet 3		
7	Titanium	7	Titanium		
8	Carbon steel	8	Nickel-plated CS		
9	304L SS	9	304L SS		
C	DV	C	DV		
D	Ductile iron	D	Nickel-plated DI		
E	ZRH	E	ZRH		
G	Zr 705	F	Zr 702		
H	LCB	G	Zr 705		
J	304 SS	H	Nickel-plated LCB		
L	316L SS	J	304 SS		
N	Inconel	L	316L SS		
U	CE3MN	N	Inconel		
		U	CE3MN		

Options	
A	Drilled & tapped flange
B	Block & bleed w/ 1/4DG432 valve
C	Chlorine service (DNZ)
K	Kalrez o-rings
N	NACE Trim
O	Commercial Oxygen Cleaned
P	Prepared for Phosgene
R	Built Dry
S	Silicone Free
V	Vacuum service, 1 micron
W	None
Z	Fire sealed - STD
@	Dupont Fluoropolymer Material
Q	Quality Plan (to appear as last option)
Adjuster fastener	
1	B840
2	B9
3	B7
4	B7MT
5	C20
6	HC
7	I718
9	B7M
B	B16
L	L7
M	MKH
T	B7T
G	1840
Top Cap Fastener	
1	B840
2	B9
3	B7
4	B7MT
5	C20
6	HC
7	I718
9	B7M
B	B16
M	MKH
T	B7T
I	I825
Manufacturers code	
M	Mfg CVO use only
Operator	
0	Std Wrench
1	Gear (CI)
3	Caustic PF (CI) with CI handwheel
7	Saginaw
9	Bare Stem
A	Adjustable T Wrench
B	Chain wheel operator
H	HighHub
V	Oval HW
Sleeve/seats	
T	PTFE
D	Durlon II
G	Glass Filled
U	UMPE sleeve w/ PFA diaphragm
A	Solid PTFE
B	Solid Durlon II
C	Solid UMPE
X	TFE/no Zyglo
Z	TM/no Zyglo
F	UMPE Sleeve



United States

Flowserve Corporation
Flow Control Division
1978 Foreman Drive
Cookeville, Tennessee 38501
Phone: 931 432 4021
Fax: 931 432 3105
www.flowserve.com

Germany

Flowserve Ahaus GmbH
Von Braun Straße 19a
D-48683 Ahaus
Germany
Phone: +49 2561 686-0
Fax: +49 2561 686-39

Singapore

Flowserve Pte. Ltd.
12 Tuas Avenue 20
Republic of Singapore 638824
Phone: +65 6879 8900
Fax: +65 6862 4940

Brazil

Av. Tocantins 128
Sao Caetano do Sul
SP 09580-130
Brazil
Tel 55 11 2169 6300
Fax 55 11 2169 6313

China

Flowserve Corporation Beijing Office
Room 22A1&A2.HanWei Plaza
No.7 GuangHua Road
Chaoyang District
Beijing, China 100004
Tel: +86-10-59210600
+86-10-59210601
Fax: +86-10-65611899

FCD DVENBR0024-01 (EN/A4) 06/22 Printed in USA.

To find your local Flowserve representative:

For more information about Flowserve Corporation, visit
www.flowserve.com or call USA 1 800 225 6989

Flowserve Corporation has established industry leadership in the design and manufacture of its products. When properly selected, this Flowserve product is designed to perform its intended function safely during its useful life. However, the purchaser or user of Flowserve products should be aware that Flowserve products might be used in numerous applications under a wide variety of industrial service conditions. Although Flowserve can (and often does) provide general guidelines, it cannot provide specific data and warnings for all possible applications. The purchaser/user must therefore assume the ultimate responsibility for the proper sizing and selection, installation, operation, and maintenance of Flowserve products. The purchaser/user should read and understand the Installation Operation Maintenance (IOM) instructions included with the product, and train its employees and contractors in the safe use of Flowserve products in connection with the specific application.

While the information and specifications contained in this literature are believed to be accurate, they are supplied for informative purposes only and should not be considered certified or as a guarantee of satisfactory results by reliance thereon. Nothing contained herein is to be construed as a warranty or guarantee, express or implied, regarding any matter with respect to this product. Because Flowserve is continually improving and upgrading its product design, the specifications, dimensions and information contained herein are subject to change without notice. Should any question arise concerning these provisions, the purchaser/user should contact Flowserve Corporation at any one of its worldwide operations or offices.

© 2022 Flowserve Corporation, Irving, Texas, USA. Flowserve is a registered trademark of Flowserve Corporation.