

Motor Alignment

A precision rabbet fit aids in the alignment of the motor shaft to the pump shaft. Pumps with larger motors are supplied with motor alignment screws.

OSHA Non-Spark Coupling Guards

Provide safety while allowing visual inspection of the coupling without guard removal.

Fabricated Discharge Head

Fabricated with ANSI 150# or 300# slip-on flanges. Functions as a mounting base for the driver.

Fabricated Suction Can

Creates optimum hydraulic conditions through the suction flange inlet into the suction bell.

Open Lineshaft Construction

Allows the lineshaft bearings to be lubricated by the pumped fluid.

Threaded or Keyed Lineshaft Couplings

Positively lock sections of lineshaft together.

Flanged Column Assembly

Utilizes precision rabbet fits to ensure proper alignment of each section. Provides transition from bowl assembly to discharge.

Bearing Retainers with Bearings

Provide shaft support in column assembly. Retainers are spaced between column sections. Pumps with larger column sizes are supplied with integral retainers.

Bowls

Designed with multiple diffuser vanes and flanged construction. Bowl bearings on either side of the impeller provide rigid support to the shaft.

Enclosed or Semi-Open Impellers

Cast to provide smooth passageways for more efficient fluid flow. First stage impeller available with low NPSH design.

Suction Bell

Designed to provide efficient fluid flow into the eye of the first stage impeller.

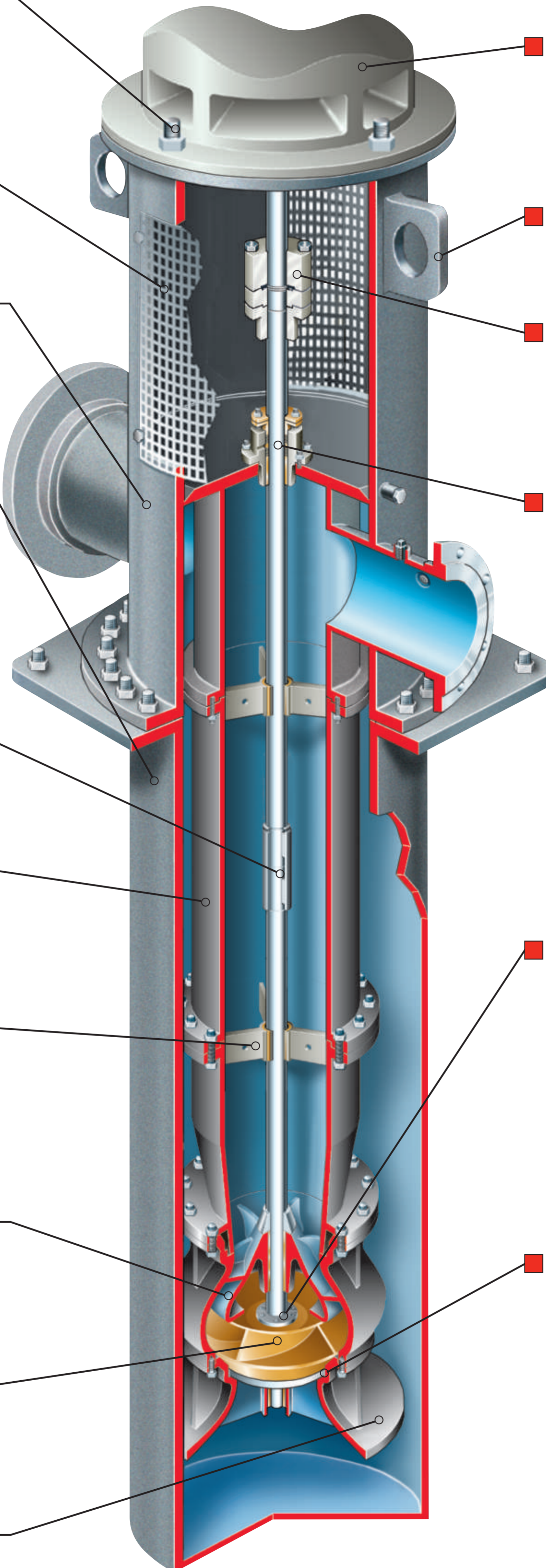

Solid Shaft Motor with Thrust Bearing
Shaft extension allows motor to be coupled to pump. Includes thrust bearing to withstand the total hydraulic thrust as well as the rotor weight.

Lifting Lugs
Permit economical two-point lifting method of pump during installation and maintenance.

Rigid, Adjustable Flanged Coupling
Provides the proper impeller clearance adjustment. A spacer coupling allows access to the mechanical seal without removing the motor.

High Pressure Seal Chamber
Accommodates low, high and extra high packed box or mechanical seal arrangements with API seal piping plans.

Separate Sole Plate

(Optional, not shown) Allows the removal of the suction can without disturbing the foundation. Sole plate and suction can flange are machined to allow precision mating.

Suction Can Drain (Optional, not shown)
Allows the suction can to be drained of pumping liquid prior to removing the pump.

Colleted or Keyed Impellers
Provide method of fastening impeller to shaft with an interference fit or a positive locking design.

O-Ring Construction (Optional)

Provides a positive seal of all flanged joints. Located at rabbet fits on bowls and column joints. Also included at discharge head to suction can fit.

Bowl and Impeller Wear Rings (Optional)
Provide a quick and easy way to renew clearances and pump efficiency. Wear rings are held into place by an interference fit or with optional pins.