

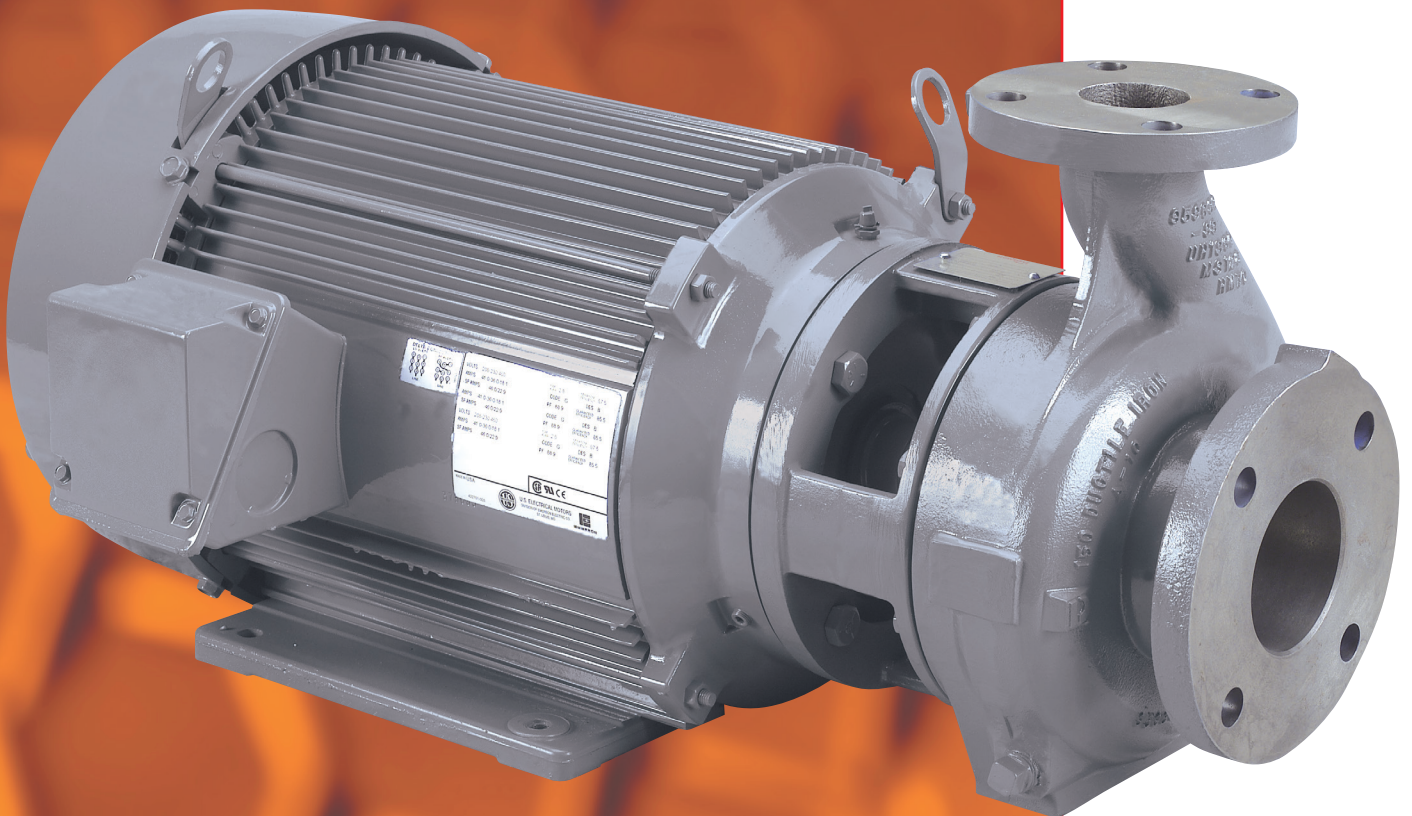

Pump Division

D800

***Frame Mounted
And Close Coupled
General Industry
Pumps***



D800
Frame Mounted
And Close Coupled
General Industry
Pumps

Trouble-Free Operation for General Industry

The D800 Series of pumps has evolved as Flowserve engineers have reacted to the growing need for economical and reliable pumps for general industrial service.

Covering a large flow and head range, the D800 is versatile and reliable. It is available in multiple configurations to suit site requirements and incorporates many proven features to reduce and facilitate maintenance.

Complementary Pump Designs

- SMP standard motor pump
- SMX non-metallic motor pump
- LR between bearing, axially split, double suction pump
- MEN end-suction water pump
- STX formed stainless steel, threaded, end-suction pump
- SFX formed stainless steel, flanged, end-suction pump

Applications

- Water
- Coolants
- Brines
- Solvents
- Light oils
- Light chemicals
- Building trades
- HVAC
- OEM

Operating Parameters

- Flows to 455 m³/h (2000 gpm)
- Heads to 150 m (500 ft)
- Temperatures to 120°C (250°F)
- Pressures to 15 bar (220 psi)

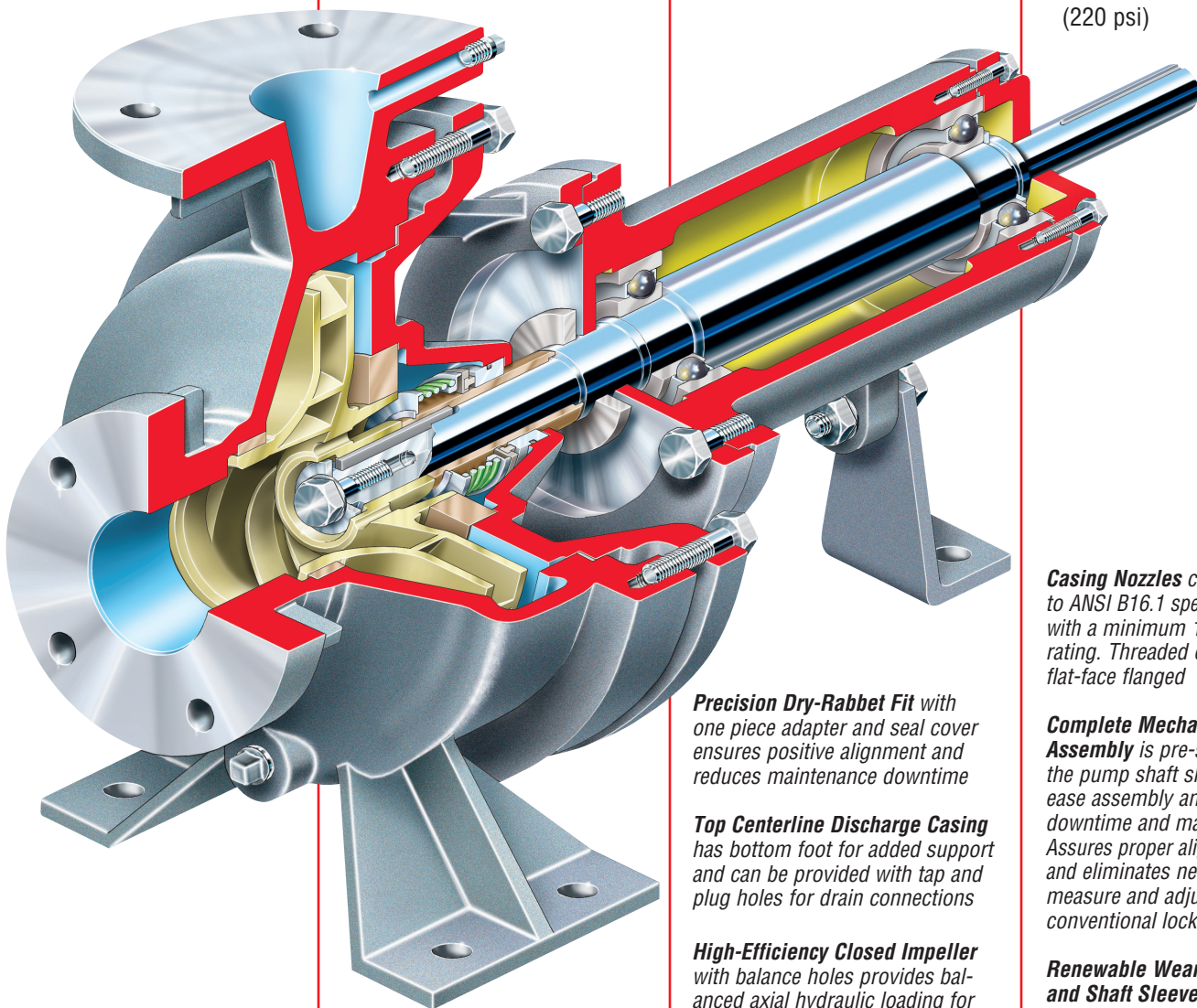

Casing Nozzles conform to ANSI B16.1 specifications with a minimum 125 psi rating. Threaded or flat-face flanged

Precision Dry-Rabbit Fit with one piece adapter and seal cover ensures positive alignment and reduces maintenance downtime

Top Centerline Discharge Casing has bottom foot for added support and can be provided with tap and plug holes for drain connections

High-Efficiency Closed Impeller with balance holes provides balanced axial hydraulic loading for longer thrust bearing life. No axial adjustment is required for efficient pump operation

Complete Mechanical Seal Assembly is pre-set on the pump shaft sleeve to ease assembly and reduce downtime and maintenance. Assures proper alignment and eliminates need to measure and adjust conventional locking collar

Renewable Wear Rings and Shaft Sleeves restore worn operating clearances and extend pump life at minimal cost

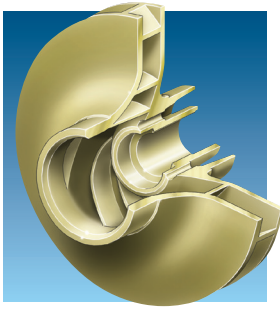

Precision Cast Closed Impeller is statically and hydraulically balanced to reduce power consumption. The impeller is keyed to shaft to provide positive drive and eliminate impeller spin-off. Balancing holes through the impeller hub minimize axial thrust and seal chamber pressure.

Designed for Reliability and Ease of Maintenance

- Bell housing mechanical seal cover
- Sealed-for-life bearings
- Pre-set mechanical seal
- Back pull-out design
- One-piece adapter
- Spacer type coupling
- Renewable wear ring
- Renewable shaft sleeve
- Standard NEMA motor on close coupled model
- Keyed impeller

Versatility and Flexibility

Bell Type Mechanical Seal Cover facilitates flushing and cooling of the seal faces

Sealed-for-Life Pre-Lubricated Motor Bearings provide two-year minimum life

Flexible Spacer Type Coupling allows pump internals to be removed without disconnecting motor leads or system piping

D800 is available in three configurations and with a number of options.

- Configuration options
 - Frame mounted (D814)
 - Close coupled (D824)
- Threaded or flat-faced flanges
- Interchangeability between the frame mounted and close coupled configurations
- Liquid end can be mounted to standard bearing housing or directly to NEMA C-face JM (JMV) shaft motor
- Kit program
- Flanged connections available through 200 mm (8 in)
- Stainless steel suction inducer



Materials of Construction

Part	Standard Fitted		All Iron Fitted		316 Stainless Steel	
	D814	D824	D814	D824	D814	D824
Casing	Cast Iron - 25				316 SS	
Case Wear Ring*	Bronze		Steel		316 SS	
Casing Gasket	Synthetic Fibers with Nitrile Binder					
Impeller	Bronze		Cast Iron - 25		316 SS	
Adapter	Cast Iron - 25				316 SS	
Shaft Sleeve	Bronze		316 SS			
Shaft and Key	Steel (Bar)					
Casing Foot	Ductile Iron	N/A	Ductile Iron	N/A	Ductile Iron	N/A
Bearing Frame	Cast Iron	N/A	Cast Iron	N/A	Cast Iron	

*Wear ring is standard with 9, 12 and 15 inch impellers. Wear ring is optional with all other sizes.

D800 Range Chart

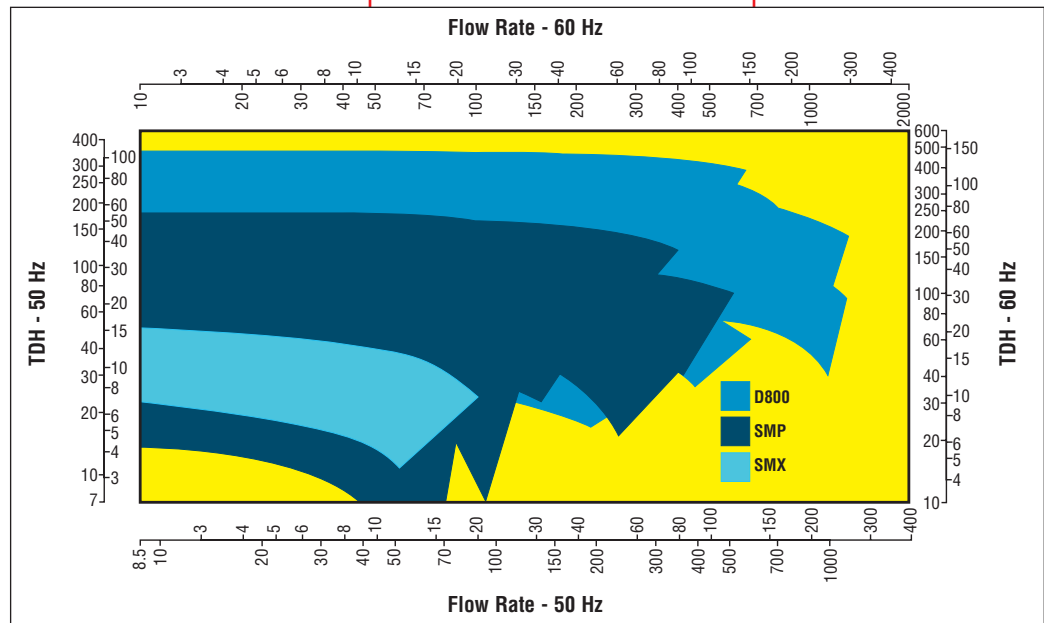

*Flowserve... Supporting Our Customers
With The World's Leading
Pump Brands*

Cameron™
Pleuger® **Durco®**
Niigata Worthington™
TKL™ **IDP®** **Pacific®** **Scienco™**
Byron Jackson®
Worthington Simpson™ **Flowserve®**
Calder™ Energy Recovery Devices **Lawrence Pumps®**
Worthington® **Sier-Bath®**
United Centrifugal® **Western Land Roller™**
Wilson-Snyder®
Aldrich™ **ACEC™**

USA and Canada

Flowserve Corporation
Pump Division
5215 North O'Connor Blvd.
Suite 2300
Irving, Texas 75039-5421 USA
Telephone: 1 972 443 6500
Telefax: 1 972 443 6800

Europe, Middle East, Africa

Flowserve Corporation
Pump Division
Parallelweg 6
Etten-Leur 4878 AH
The Netherlands
Telephone: 31 76 502 8300
Telefax: 31 76 502 8359



Your local Flowserve representative:

**To find your local Flowserve representative
please use the Sales Support Locator System
found at www.flowserve.com**

Or call toll free: 1 800 728 PUMP (7867)

Latin America and Caribbean

Flowserve Corporation
Pump Division
6840 Wynnwood Lane
Houston, Texas 77008 USA
Telephone: 1 713 803 4434
Telefax: 1 713 803 4497

Asia Pacific

Flowserve Pte. Ltd.
Pump Division
200 Pandan Loop #06-03/04
Pantech 21
Singapore 128388
Telephone: 65 6775 3003
Telefax: 65 6779 4607