



USER INSTRUCTIONS

NMD, NMAD centrifugal pumps

Multi-stage, vertical, simple suction and radial joint plan pump type centrifugal pumps

PCN=71576436 – 11/09 (E) Original instructions.

***Installation
Operation
Maintenance***

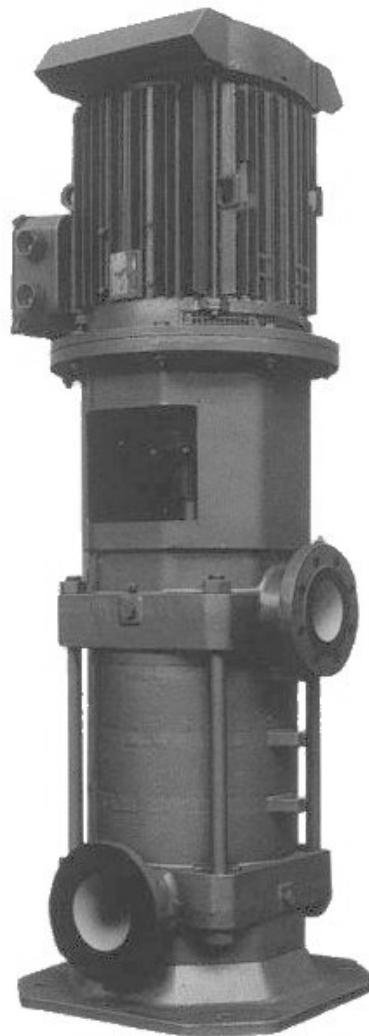

CONTENTS

	PAGE		PAGE
1 INTRODUCTION AND SAFETY	4	6 MAINTENANCE	22
1.1 GENERAL	4	6.1 GENERAL.....	22
1.2 CE MARKING AND APPROVALS	4	6.3 SPARE PARTS.....	25
1.3 DISCLAIMER.....	4	6.4 RECOMMENDED SPARES AND CONSUMABLE ITEMS	25
1.4 COPYRIGHT	4	25
1.5 DUTY CONDITIONS	4	6.5 DISASSEMBLY	25
1.6 SAFETY	5	7 FAULTS; CAUSES AND REMEDIES	27
1.7 NAMEPLATE AND SAFETY LABELS.....	8	8 PARTS LIST AND DRAWINGS	28
1.8 SPECIFIC MACHINE PERFORMANCE	8	8.1 SECTIONAL DRAWINGS	28
2 TRANSPORT AND STORAGE	10	8.2 SECTIONAL DRAWINGS PART LIST	34
2.1 CONSIGNMENT RECEIPT AND UNPACKING.....	10	8.3 GENERAL ARRANGEMENT DRAWING	36
2.2 HANDLING	10	9 CERTIFICATION	36
2.3 LIFTING	11	10 OTHER RELEVANT DOCUMENTATION AND	
2.4 STORAGE	12	MANUALS.....	36
2.5 RECYCLING AND END OF PRODUCT LIFE.....	12	10.1 SUPPLEMENTARY USER INSTRUCTIONS	36
3 PUMP DESCRIPTION.....	12	10.2 CHANGE NOTES	36
3.1 CONFIGURATIONS	12	10.3 ADDITIONAL SOURCES OF INFORMATION	36
3.2 NOMENCLATURE	13		
4 INSTALLATION.....	13		
4.1 LOCATION.....	13		
4.2 FOUNDATION	14		
4.3 INITIAL ALIGNMENT	15		
4.4 PIPING	15		
4.5 ELECTRICAL CONNECTIONS	17		
4.6 FINAL SHAFT ALIGNMENT CHECK.....	17		
4.7 PROTECTION SYSTEMS.....	17		
5 COMMISSIONING, START-UP, OPERATION AND			
SHUTDOWN.....	18		
5.1 DIRECTION OF ROTATION	18		
5.3 PRIMING AND AUXILIARY SUPPLIES	18		
5.4 STARTING THE PUMP	19		
5.5 RUNNING THE PUMP	19		
5.6 STOPPING AND SHUTDOWN.....	21		
5.7 HYDRAULIC, MECHANICAL AND ELECTRICAL DUTY			
.....	21		
5.8 PUMPS FOR FOOD USE OR POTABLE WATER ...	22		

INDEX

	PAGE		PAGE
Additional sources (10.3)	36	Safety, protection systems (see 1.6 and 4.7)	5
Alignment of shafting (see 4.2, 4.3 and 4.6)		Sectional drawings (8.1)	28
ATEX marking (1.6.4.2)	7	Sound level (see 1.9, Noise level)	9
CE marking and approvals (1.2)	4	Sources, additional information (10.3)	36
Certification (9)	36	Spare parts (6.3)	25
Change notes (10.2)	36	Specific machine performance (1.8)	8
Cleaning prior to operation (5.8.1)	22	Standard maintenance (6.2.1)	23
Commissioning, start-up, operation (5)	18	Starting the pump (5.4)	19
Compliance, ATEX (1.6.4.1)	6	Stop/start frequency (5.5.6)	21
Configurations (3.1)	12	Stopping and shutdown (5.6)	21
Copyright (1.4)	4	Storage, pump (2.4)	12
Direction of rotation (5.1)	18	Storage, spare parts (6.3.2)	25
Disassembly (6.5)	25	Suction piping (4.4.2)	16
Discharge piping (4.4.3)	16	Supplementary manuals or information sources ...	36
Disclaimer (1.3)	4	Thermal expansion (4.3.1)	15
Dismantling (see 6.5, Disassembly)	25	Transport and storage (2)	10
Drawings (8.1)	28	Trouble-shooting (see 7)	27
Duty conditions (1.5)	4	Vibration (5.5.5)	20
Electrical connections (4.5)	17	Safety labels (1.7.2)	8
End of product life (2.5)	12		
Faults; causes and remedies (7)	27		
Final checks (4.4.4)	17		
First pump start up (5.4.2)	19		
Foundation (4.2)	14		
Forces and moments (see 4.4.1)	15		
General arrangement drawing (8.3)	36		
Gland packing (6.2.5)	24		
Guarding (5.2)	18		
Handling (2.2)	10		
Hydraulic, mechanical and electrical duty (5.7)	21		
Inspection (6.2.2 and 6.2.3)	23		
Installation (4)	13		
Internal coating (6.2.6)	25		
Lifting (2.3)	11		
Location (4.1)	13		
Maintenance (6)	22		
Maintenance schedule (6.2)	23		
Mechanical seal (6.2.4)	24		
Nomenclature (3.2)	13		
Nameplate (1.7.1)	8		
Operating limits (see 3.1)	12		
Ordering spare parts (6.3.1)	25		
Parts lists (8.2)	34		
Piping (4.5)	17		
Protection systems (4.7)	17		
Pump masses (2.2.2)	11		
Receipt and unpacking (2.1)	10		
Recommended fill quantities (see 6.2.1)	23		
Recommended grease lubricants (see 6.2.1)	23		
Recommended spares (6.4)	25		
Recycling (2.5)	12		
Replacement parts (see 6.3 and 6.4)	25		
Running the pump (5.5)	19		
Safety action (1.6.3)	5		
Safety markings (1.6.1)	5		

1 INTRODUCTION AND SAFETY

1.1 General



These instructions must always be kept close to the product's operating location or directly with the product.

Flowserve's products are designed, developed and manufactured with state-of-the-art technologies in modern facilities. The unit is produced with great care and commitment to continuous quality control, utilizing sophisticated quality techniques, and safety requirements.

Flowserve is committed to continuous quality improvement and being at service for any further information about the product in its installation and operation or about its support products, repair and diagnostic services.

These instructions are intended to facilitate familiarization with the product and its permitted use. Operating the product in compliance with these instructions is important to help ensure reliability in service and avoid risks. The instructions may not take into account local regulations; ensure such regulations are observed by all, including those installing the product. Always coordinate repair activity with operations personnel, and follow all plant safety requirements and applicable safety and health laws and regulations.



These instructions must be read prior to installing, operating, using and maintaining the equipment in any region worldwide. The equipment must not be put into service until all the conditions relating to safety noted in the instructions, have been met. Failure to follow and apply the present user instructions is considered to be misuse. Personal injury, product damage, delay or failure caused by misuse are not covered by the Flowserve warranty.

1.2 CE marking and approvals

It is a legal requirement that machinery and equipment put into service within certain regions of the world shall conform with the applicable CE Marking Directives covering Machinery and, where applicable, Low Voltage Equipment, Electromagnetic Compatibility (EMC), Pressure Equipment Directive (PED) and Equipment for Potentially Explosive Atmospheres (ATEX).

Where applicable the Directives and any additional Approvals cover important safety aspects relating to machinery and equipment and the satisfactory provision of technical documents and safety instructions. Where applicable this document incorporates information relevant to these Directives and Approvals.

To confirm the Approvals applying and if the product is CE marked, check the serial number plate markings and the Certification. (See section 9, *Certification*.)

1.3 Disclaimer

Information in these User Instructions is believed to be reliable. In spite of all the efforts of Flowserve Pump Division to provide sound and all necessary information the content of this manual may appear insufficient and is not guaranteed by Flowserve as to its completeness or accuracy.

Flowserve manufactures products to exacting International Quality Management System Standards as certified and audited by external Quality Assurance organizations. Genuine parts and accessories have been designed, tested and incorporated into the products to help ensure their continued product quality and performance in use. As Flowserve cannot test parts and accessories sourced from other vendors the incorrect incorporation of such parts and accessories may adversely affect the performance and safety features of the products. The failure to properly select, install or use authorized Flowserve parts and accessories is considered to be misuse. Damage or failure caused by misuse is not covered by the Flowserve warranty. In addition, any modification of Flowserve products or removal of original components may impair the safety of these products in their use.

1.4 Copyright

All rights reserved. No part of these instructions may be reproduced, stored in a retrieval system or transmitted in any form or by any means without prior permission of Flowserve.

1.5 Duty conditions

This product has been selected to meet the specifications of your purchaser order. The acknowledgement of these conditions has been sent separately to the Purchaser. A copy should be kept with these instructions.



The product must not be operated beyond the parameters specified for the application. If there is any doubt as to the suitability of the product for the application intended, contact Flowserve for advice, quoting the serial number.

If the conditions of service on your purchase order are going to be changed (for example liquid pumped, temperature or duty) it is requested that the user seeks the written agreement of Flowserve before start up.

1.6 Safety

1.6.1 Summary of safety markings

These User Instructions contain specific safety markings where non-observance of an instruction would cause hazards. The specific safety markings are:



DANGER This symbol indicates electrical safety instructions where non-compliance will involve a high risk to personal safety or the loss of life.



This symbol indicates safety instructions where non-compliance would affect personal safety and could result in loss of life.



This symbol indicates “hazardous substances and toxic fluid” safety instructions where non-compliance would affect personal safety and could result in loss of life.



This symbol indicates safety instructions where non-compliance will involve some risk to safe operation and personal safety and would damage the equipment or property.



This symbol indicates explosive atmosphere zone marking according to ATEX. It is used in safety instructions where non-compliance in the hazardous area would cause the risk of an explosion.



This symbol is used in safety instructions to remind not to rub non-metallic surfaces with a dry cloth; ensure cloth is damp. It is used where non-compliance in the hazardous area would cause the risk of an explosion.

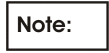

This sign is not a safety symbol but indicates an important instruction in the assembly process.

1.6.2 Personnel qualification and training

All personnel involved in the operation, installation, inspection and maintenance of the unit must be qualified to carry out the work involved. If the personnel in question do not already possess the necessary knowledge and skill, appropriate training and instruction must be provided. If required the operator may commission the manufacturer/supplier to provide applicable training.

Always coordinate repair activity with operations and health and safety personnel, and follow all plant safety requirements and applicable safety and health laws and regulations.

1.6.3 Safety action

This is a summary of conditions and actions to prevent injury to personnel and damage to the environment and to equipment. For products used in potentially explosive atmospheres section 1.6.4 also applies.



DANGER NEVER DO MAINTENANCE WORK WHEN THE UNIT IS CONNECTED TO POWER



GUARDS MUST NOT BE REMOVED WHILE THE PUMP IS OPERATIONAL



DRAIN THE PUMP AND ISOLATE PIPEWORK BEFORE DISMANTLING THE PUMP The appropriate safety precautions should be taken where the pumped liquids are hazardous.



FLUORO-ELASTOMERS (When fitted.) When a pump has experienced temperatures over 250 °C (482 °F), partial decomposition of fluoro-elastomers (example: Viton) will occur. In this condition these are extremely dangerous and skin contact must be avoided.



HANDLING COMPONENTS

Many precision parts have sharp corners and the wearing of appropriate safety gloves and equipment is required when handling these components. To lift heavy pieces above 25 kg (55 lb) use a crane appropriate for the mass and in accordance with current local regulations.



THERMAL SHOCK

Rapid changes in the temperature of the liquid within the pump can cause thermal shock, which can result in damage or breakage of components and should be avoided.



NEVER APPLY HEAT TO REMOVE IMPELLER

Trapped lubricant or vapour could cause an explosion.



HOT (and cold) PARTS

If hot or freezing components or auxiliary heating supplies can present a danger to operators and persons entering the immediate area action must be taken to avoid accidental contact. If complete protection is not possible, the machine access must be limited to maintenance staff only, with clear visual warnings and indicators to those entering the immediate area. Note: bearing housings must not be insulated and drive motors and bearings may be hot.

If the temperature is greater than 68 °C (155 °F) or below -5 °C (23 °F) in a restricted zone, or exceeds local regulations, action as above shall be taken.



HAZARDOUS LIQUIDS

When the pump is handling hazardous liquids care must be taken to avoid exposure to the liquid by appropriate siting of the pump, limiting personnel access and by operator training. If the liquid is flammable and/or explosive, strict safety procedures must be applied.

Gland packing must not be used when pumping hazardous liquids.



PREVENT EXCESSIVE EXTERNAL PIPE LOAD

Do not use pump as a support for piping. Do not mount expansion joints, unless allowed by Flowserve in writing, so that their force, due to internal pressure, acts on the pump flange.



ENSURE CORRECT LUBRICATION

(See section 5, *Commissioning, startup, operation and shutdown.*)



START THE PUMP WITH OUTLET VALVE PART OPENED

(Unless otherwise instructed at a specific point in the User Instructions.)

This is recommended to minimize the risk of overloading and damaging the pump motor at full or zero flow. Pumps may be started with the valve further open only on installations where this situation cannot occur. Pump outlet valve shall may need to be adjusted to comply with the duty following the run-up process. (See section 5, *Commissioning start-up, operation and shutdown.*)



NEVER RUN THE PUMP DRY



INLET VALVES TO BE FULLY OPEN WHEN PUMP IS RUNNING

Running the pump at zero flow or below the recommended minimum flow continuously will cause damage to the seal.



DO NOT RUN THE PUMP AT ABNORMALLY HIGH OR LOW FLOW RATES

Operating at a flow rate higher than normal or at a flow rate with no backpressure on the pump may overload the motor and cause cavitations. Low flow rates may cause a reduction in pump/bearing life, overheating of the pump, instability and cavitations/vibration.

1.6.4 Products used in potentially explosive atmospheres



The following instructions for pumps and pump units when installed in potentially explosive atmospheres must be followed to help ensure explosion protection.

The terminology and procedures ensure that the installed pump is in compliance with the European Directive 94/9/EC, known as the ATEX Directive, which is mandatory in Europe and may also be specified in other countries. Where applicable, both electrical and non-electrical equipment must meet the requirements 94/9/EC.

Even if the installation is in a region where ATEX is not the applicable regulation, the general measures described shall be followed to ensure safe operation.

The measures are explained under the headings of:

- Avoiding excessive surface temperature.
- Preventing build up of explosive mixtures.
- Preventing the generation of sparks.
- Preventing leakages.
- Maintaining the pump to avoid hazard.

1.6.4.1 Scope of compliance



Use equipment only in the zone for which it is appropriate. Always check that the driver, drive coupling assembly, seal and pump equipment are suitably rated and/or certified for the classification of the specific atmosphere in which they are to be installed.

Where Flowserve has supplied only the bare shaft pump, the Ex rating applies only to the pump. The party responsible for assembling the pump set shall select the coupling, driver and any additional equipment, with the necessary CE Declaration of Conformity establishing it is suitable for the area in which it is to be installed.

The output from a variable frequency drive (VFD) can cause additional heating affects in the motor and so, for pumps sets with a VFD, the ATEX Certification for the motor must state that it is covers the situation where electrical supply is from the VFD. This particular requirement still applies even if the VFD is in a safe area.

1.6.4.2 Marking

An example of ATEX equipment marking is shown below. The actual classification of the pump will be engraved on the nameplate.

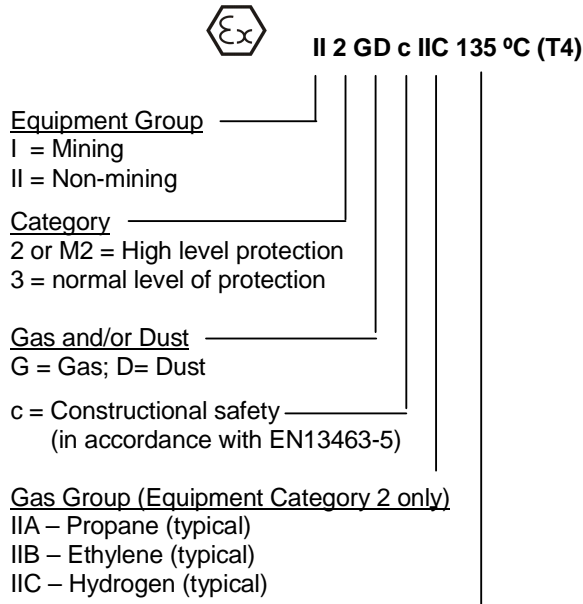

Maximum surface temperature (Temperature Class)
(see section 1.6.4.3)

1.6.4.3 Avoiding excessive surface temperatures

ENSURE THE EQUIPMENT TEMPERATURE CLASS IS SUITABLE FOR THE HAZARD ZONE

Pumps have a temperature class as stated in the ATEX Ex rating on the nameplate. These are based on a maximum ambient of 40 °C (104 °F); refer to Flowserve for higher ambient temperatures.

The surface temperature on the pump is influenced by the temperature of the liquid handled. The maximum permissible liquid temperature depends on the temperature class and must not exceed the values in the table that follows.

The temperature rise at the seals, bearings and due to the minimum permitted flow rate is taken into account in the temperatures stated.

Temperature class to prEN 13463-1	Maximum surface temperature permitted	Temperature limit of liquid handled (* depending on material and construction variant - check which is lower)
T6	85 °C (185 °F)	Consult Flowserve
T5	100 °C (212 °F)	Consult Flowserve
T4	135 °C (275 °F)	115 °C (239 °F) *
T3	200 °C (392 °F)	180 °C (356 °F) *
T2	300 °C (572 °F)	275 °C (527 °F) *
T1	450 °C (842 °F)	400 °C (752 °F) *

The responsibility for compliance with the specified maximum liquid temperature is with the plant operator.

Temperature classification “Tx” is used when the liquid temperature varies and the pump could be installed in different hazardous atmospheres. In this case the user is responsible for ensuring that the pump surface temperature does not exceed that permitted in the particular hazardous atmosphere.

If an explosive atmosphere exists during the installation, do not attempt to check the direction of rotation by starting the pump unfilled. Even a short run time may give a high temperature resulting from contact between rotating and stationary components. Furthermore, confinement of liquid in the pump and pipes must be avoided (valve closed). If the liquid heats up this may cause excessive pressure and lead to bursting of pump components.

Where there is any risk of the pump being run against a closed valve generating high liquid and casing external surface temperatures it is recommended that users fit an external surface temperature protection device.

Avoid mechanical, hydraulic or electrical overload by using motor overload trips, temperature monitor or a power monitor and make routine vibration monitoring checks.

In dirty or dusty environments, regular checks must be made and dirt removed from areas around close clearances, bearing housings and motors.

1.6.4.4 Preventing the build up of explosive mixtures

ENSURE PUMP IS PROPERLY FILLED AND VENTED AND DOES NOT RUN DRY.

Ensure pump and relevant suction and discharge pipeline system is totally filled with liquid at all times during the pump operation, so that an explosive atmosphere is prevented. In addition it is essential to make sure that seal chambers, auxiliary shaft seal systems and any heating and cooling systems are properly filled.

If the operation of the system cannot avoid this condition the fitting of an appropriate dry run protection device is recommended (eg liquid detection or power monitor).

To avoid potential hazards from fugitive emissions of vapour or gas to atmosphere the surrounding area must be well ventilated.

1.6.4.5 Preventing sparks

To prevent a potential hazard from mechanical contact, the coupling guard must be non-sparking.

To avoid the potential hazard from random induced current generating a spark the ground contact on the baseplate must be used.

Avoid electrostatic charge: do not rub non-metallic surfaces with a dry cloth, ensure cloth is damp.

Where applicable the coupling must be selected to comply with 94/9/EC and correct alignment must be maintained.

Additional requirements for metallic pumps on non-metallic baseplates.

When metallic components are fitted on a non-metallic baseplate they must be individually earthed (grounded).

1.6.4.6 Preventing leakage

The pump must only be used to handle liquids for which it has been approved to have the correct corrosion resistance.

Avoid entrapment of liquid in the pump and associated piping due to closing of suction and discharge valves, which could cause dangerous excessive pressures to occur if there is heat input to the liquid. This can occur if the pump is stationary or running.

Bursting of liquid containing parts due to freezing must be avoided by draining or protecting the pump and ancillary systems.

Where there is the potential hazard of a loss of a seal barrier fluid or external flush, the fluid must be monitored.

If leakage of liquid to atmosphere can result in a hazard, the installation of a liquid detection device is recommended.

1.6.4.7 Maintenance to avoid the hazard

CORRECT MAINTENANCE IS REQUIRED TO AVOID POTENTIAL HAZARDS WHICH GIVE A RISK OF EXPLOSION

The responsibility for compliance with maintenance instructions is with the plant operator.

To avoid potential explosion hazards during maintenance, the tools, cleaning and painting materials used must not give rise to sparking or adversely affect the ambient conditions. Where there is a risk from such tools or materials; maintenance must be conducted in a safe area. It is recommended that a maintenance plan and schedule is adopted. (See section 6, *Maintenance*.)

1.7 Nameplate and safety labels

1.7.1 Nameplate

For details of nameplate, see the *Declaration of Conformity*, or separate documentation included with these User Instructions.

1.7.2 Safety labels

		WARNING	J218JZ250
ESSENTIAL PROCEDURES BEFORE STARTING:			
INSTALL AND OPERATE EQUIPMENT IN ACCORDANCE WITH THE INSTRUCTION MANUAL SUPPLIED SEPARATELY.	ENSURE ALL EXTERNAL CONNECTIONS TO THE PUMP / SHAFT SEALING AND DRIVER ARE CONNECTED AND OPERATIONAL.	FULLY PRIME UNIT AND SYSTEM. DO NOT RUN UNIT DRY.	
ENSURE GUARDS ARE SECURELY IN PLACE.	FAILURE TO FOLLOW THESE PROCEDURES MAY RESULT IN PERSONAL INJURY AND / OR EQUIPMENT DAMAGE		
ENSURE CORRECT DIRECTION OF ROTATION.			

		J218JZ268
ENSURE UNIT ON A FIRM FOUNDATION AND THAT COUPLING FACES ARE IN CORRECT ALIGNMENT PRIOR TO AND AFTER BOLTING BASEPLATE DOWN AND FIXING PIPEWORK. SEE MANUAL FOR TOLERANCES.	PUMP MUSS AUF FESTEM FUNDAMENT STEHEN. KUPPLUNGSHÄLFEN KORREKT AXIAL AUSRICHTEN, DANN PUMPE AUF GRUNDPLATTE FESTSPANNEN UND ANSCHLUSSLEITUNGEN BEFESTIGEN. TOLERANZEN S. BEDIENUNGSANLEITUNG.	
S'ASSURER QUE LE GROUPE ELECTROPOMPE EST FERME ET INSTALLE SUR SON MASSIF. VERIFIER LE LIGNAGE DE L'ACCOUPLLEMENT AVANT ET APRES FIXATION DU SOCLE ET DE LA TUYAUTERIE. VOIR LES TOLERANCES D'ALIGNEMENT SUR LA NOTICE	ZORG DAT POMPEENHEID OP EEN STEVIGE ONDERGROND OPGESTELD STAAT EN DAT KOPPELING CORRECT UITGELIJNT IS ZOWEL VOOR ALS NADAT DE GRONDPLAAT MET BOUTEN IS VASTGEZET EN DE LEIDINGEN GEINSTALLEERD ZIJN. ZIE HANDLEIDING VOOR TOELAABARE SPELINGEN.	
CDC: 603 604 610 612 621 623 624		

Oil lubricated units only:

		J218JZ262
WARNING ATTENTION	THIS MACHINE MUST BE FILLED WITH OIL BEFORE STARTING CETTE MACHINE DOIT ÊTRE REMPLIE D'HUILE AVANT LA MISE EN MARCHÉ	
ACHTUNG WAARSCHUWING	DEISE MASCHINE IST VOR DEM STARTEN MIT ÖL ZÜ FULLEN DEZE MASCHINE MOET VOOR HET STARTEN MET OLIE GEVULD WORDEN	
CDC: 603 604 610 612 621 623 624		

1.8 Specific machine performance

For performance parameters see section 1.5, *Duty conditions*. When the contract requirement specifies these to be incorporated into User Instructions these are included here. Where performance data has been supplied separately to the purchaser these should be obtained and retained with these User Instructions if required.

1.9 Noise level

Attention must be given to the exposure of personnel to the noise, and local legislation will define when guidance to personnel on noise limitation is required, and when noise exposure reduction is mandatory. This is typically 80 to 85 dBA.

The usual approach is to control the exposure time to the noise or to enclose the machine to reduce emitted sound. You may have already specified a limiting noise level when the equipment was ordered, however if no noise requirements were defined, then attention is drawn to the following table to give an indication of equipment noise level so that you can take the appropriate action in your plant.

Pump noise level is dependent on a number of operational factors, flow rate, pipework design and acoustic characteristics of the building, and so the values given are subject to a 3 dBA tolerance and cannot be guaranteed.

Similarly the motor noise assumed in the “pump and motor” noise is that typically expected from standard and high efficiency motors when on load directly driving the pump. Note that a motor driven by an inverter may show an increased noise at some speeds.

If a pump unit only has been purchased for fitting with your own driver then the “pump only” noise levels in the table should be combined with the level for the driver obtained from the supplier. Consult Flowserve or a noise specialist if assistance is required in combining the values.

It is recommended that where exposure approaches the prescribed limit, then site noise measurements should be made.

The values are in sound pressure level L_{pA} at 1 m (3.3 ft) from the machine, for “free field conditions over a reflecting plane”.

For estimating sound power level L_{WA} (re 1 pW) then add 17 dBA to the sound pressure value.

Motor size and speed kW (hp)	Typical sound pressure level L_{pA} at 1 m reference 20 μ Pa, dBA							
	3 550 r/min		2 900 r/min		1 750 r/min		1 450 r/min	
	Pump only	Pump and motor	Pump only	Pump and motor	Pump only	Pump and motor	Pump only	Pump and motor
<0.55(<0.75)	72	72	64	65	62	64	62	64
0.75 (1)	72	72	64	66	62	64	62	64
1.1 (1.5)	74	74	66	67	64	64	62	63
1.5 (2)	74	74	66	71	64	64	62	63
2.2 (3)	75	76	68	72	65	66	63	64
3 (4)	75	76	70	73	65	66	63	64
4 (5)	75	76	71	73	65	66	63	64
5.5 (7.5)	76	77	72	75	66	67	64	65
7.5 (10)	76	77	72	75	66	67	64	65
11(15)	80	81	76	78	70	71	68	69
15 (20)	80	81	76	78	70	71	68	69
18.5 (25)	81	81	77	78	71	71	69	71
22 (30)	81	81	77	79	71	71	69	71
30 (40)	83	83	79	81	73	73	71	73
37 (50)	83	83	79	81	73	73	71	73
45 (60)	86	86	82	84	76	76	74	76
55 (75)	86	86	82	84	76	76	74	76
75 (100)	87	87	83	85	77	77	75	77
90 (120)	87	88	83	85	77	78	75	78
110 (150)	89	90	85	87	79	80	77	80
150 (200)	89	90	85	87	79	80	77	80
200 (270)	①	①	①	①	85	87	83	85
300 (400)					87	90	85	86

① The noise level of machines in this range will most likely be of values which require noise exposure control, but typical values are inappropriate.
Note: for 1 180 and 960 r/min reduce 1 450 r/min values by 2 dBA. For 880 and 720 r/min reduce 1 450 r/min values by 3 dBA.

In areas where the staff has to intervene, remember that when the level of the sound pressure is:

- below 70 dBA: it is not necessary to take special precautions.
- above 70 dBA: people working continuously in the machine room must be supplied with protective devices against noise.
- below 85 dBA: no particular measures need to be taken for casual visitors staying in the room during a limited period.
- above 85 dBA: the room must be considered as a dangerous area because of the noise and a warning sign must be fixed at each entry warning the people coming into the room, even for a short period, that they must wear hearing protection.
- above 105 dBA: special hearing protection adapted to this noise level and to the spectral noise components must be installed and a warning sign to this effect erected at each entry. The staff in the room must wear ear protection.

Make sure that the noise, which travels through the walls and windows, does not generate too high noise levels in the machine room's surroundings.

2 TRANSPORT AND STORAGE

2.1 Consignment receipt and unpacking

Immediately after receipt of the equipment it must be checked against the delivery and shipping documents for its completeness and that there has been no damage in transportation.

Any shortage and or damage must be reported immediately to Flowserve Pump Division and received in writing within one month of receipt of the equipment. Later claims cannot be accepted.

Check any crate, boxes and wrappings for any accessories or spare parts that may be packed separately with the equipment or attached to sidewalls of the box or equipment.

Each product has a unique serial number. Check that this number corresponds with that advised and always quote this number in correspondence as well as when ordering spare parts or further accessories.

2.2 Handling

2.2.1 General instructions concerning handling

Boxes, crates, pallets or cartons may be unloaded using forklift vehicles or slings dependent on their size and construction. See 2.3.1 for positioning of slings.

To lift heavy pieces above 25 kg (55 lb), use a winch adapted to the mass and in accordance with the current local regulations.

To lift machines or pieces with one or several suspension rings, only use hooks and chains in compliance with the local regulations concerning safety. Never put cables, chains or ropes directly on or in the suspension rings. Cables, chains or lifting ropes must never present excessive bending.

Never bend the lifting hooks, suspension rings, chains, etc., which should only be made to endure stresses within, calculated limits. Remember that the capacity of a lifting device decreases when the direction of the lifting force direction makes an angle with the device axis.

To increase the safety and the efficiency of the lifting device, all the lifting elements must be as perpendicular as possible. If necessary a lifting beam can be placed between the winch and the load.

When heavy pieces are lifted up, never stay or work under the load or in the area, which could be in the path of the load if it were to swing or fall away. Never leave a load hanging from a winch. The acceleration or the slowing-down of lifting equipment must stay in the safety limits for the staff.

A winch must be positioned in such a way that the load will be raised perpendicularly. Where possible necessary precautions must be taken to avoid the swing of the load, using for example two winches making approximately the same angle, below 30°, with the vertical.

2.2.2 Pump masses

All masses are in kg:

Pump type	2 stages	3 stages	4 stages	5 stages	6 stages	7 stages	8 stages	9 stages
102 NMD	322	361	400	439	478	517	556	595
122 NMD	755	830	905	980	1055			
152 NMD	1005	1125	1245	1365	1485			
202 NMD	1205	1405	1605					
252 NMD	1600	1920						
102 NMAD	305	344	383	422	461	500	539	578
122 NMAD	700	775	850	925	1000			
152 NMAD	950	1070	1190	1310				
202 NMAD	1125	1325						

All motors (for masses see the motor description plate) must be handled with a winch.

For masses above 25 kg (55 lb), manual handling is forbidden.

2.3 Lifting

2.3.1 Slings of motor pumps units

Use handling means in accordance with motor pump unit mass mentioned on the CE plate. For the masses of the pumps bare end of shaft see table § 2.2.2 and nameplate.

CAUTION To avoid distortion and for the safety of the pump unit and personnel, do not handle the pump unit (motor + pump) by the lifting eyes of the motor. The pump unit should be lifted as shown on the sketch below.

A crane must be used for all pump sets in excess of 25kg (55 lb). Fully trained personnel must carry out lifting, in accordance with local regulations.

CAUTION Refer to the motor manual for motor handling

Bareshaft pump

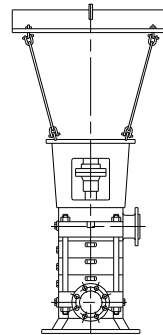

When handling always wear gloves, safety boots and an industrial safety helmet.

For masses above 25 kg (55 lb), manual handling is forbidden.

Pump Type	Bolting torque Pump / Motor bolting (Bolting diameter according to motor configuration)
102 NMD	M16 : 140 Nm / M22 : 310 Nm
122 NMD	M16 : 140 Nm / M22 (motor IP55) : 500 Nm / M22 (motor IP23) : 310 Nm
152 NMD	M16 : 140 Nm / M22 (motor IP55) : 500 Nm / M22 (motor IP23 <= 160 kW) : 310 Nm / M22 (motor IP23 > 160 kW) : 500 Nm
202 NMD	M22 (motor <= 160 kW) : 310 Nm / M22 (motor > 160 kW) : 500 Nm
252 NMD	M24 : 390 Nm
102 NMAD	M16 : 140 Nm / M22 : 310 Nm
122 NMAD	M16 : 140 Nm / M22 (motor IP55) : 500 Nm / M22 (motor IP23) : 310 Nm
152 NMAD	M16 : 140 Nm / M22 (motor IP55) : 500 Nm / M22 (motor IP23 <= 250 kW) : 310 Nm / M22 (motor IP23 > 250 kW) : 500 Nm
202 NMAD	M22 (motor <= 160 kW) : 310 Nm / M22 (motor > 160 kW) : 500 Nm

2.4 Storage



Store the pump in a clean, dry location away from vibration. Leave piping connection covers in place to keep dirt and other foreign material out of pump casing. Turn pump at intervals to prevent brinelling of the bearings and the seal faces, if fitted, from sticking.

Do not store pumps starting on the fan guard.

The pump may be stored as above for up to 6 months. Consult Flowserve for preservative actions when a longer storage period is needed.

2.5 Recycling and end of product life

At the end of the service life of the product or its parts, the relevant materials and parts should be recycled or disposed of using an environmentally acceptable method and local regulations. If the product contains substances which are harmful to the environment, these should be removed and disposed of in accordance with current regulations. This also includes the liquids and or gases in the "seal system" or other utilities.



Make sure that hazardous substances or toxic fluid are disposed of safely and that the correct personal protective equipment is used. The safety specifications must be in accordance with the current regulations at all times.

3 PUMP DESCRIPTION

3.1 Configurations

The NMD or NMAD type pump is a vertical, multi-stage, simple suction and radial joint plan pump. This pump is designed for the pumping of cold water or all clear liquids which are not solid and liquid mixtures, corrosive, abrasive or explosive when in contact with the pump motor unit and its working parts (Important: for other liquids consult FLOWSERVE for preliminary advice).

- The modular design (2 hydraulics by pump type, number of stages variation) enables an accurate pump adjustment to the required operating conditions
- Guiding bush in suction casing
- Semi-flexible coupling: NMD
- Removable rigid coupling: NMAD
- Standardized motor



The pump must be stored in a non-explosive, ventilated location, sheltered from bad weather, dust and vibrations.

The reliability of the delivered machine can only be ensured if it is used according to the conditions given in this manual. The maximum values specified in this manual must never be exceeded.

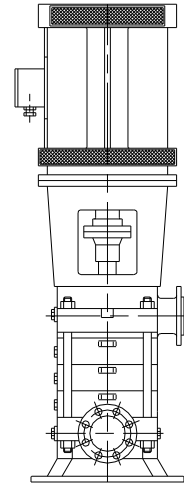

- Maximum working pressure at discharge:
 - 102 NMD - 102 NMAD 25 bars
 - 122 NMD - 122 NMAD 25 bars
 - 152 NMD - 152 NMAD 30 bars
 - 202 NMD - 202 NMAD 35 bars
 - 252 NMD 40 bars
- Maximum working pressure at suction
 - 10 bars
 - 16 bars for **252 NMD**
- Maximum pumped fluid temperature
 - Gland packing 105 °C
 - Mechanical seal 80 °C
- Minimum pumped fluid temperature.... -10 °C
- Maximum solid suspension 50 g/m³
- Density..... 1
- Viscosity 1 mm²/s
- Frequency 50 Hz (1470 min⁻¹)
- Maximum number of stages
 - 102 NMD....9 stages - 102 NMAD....9 stages
 - 122 NMD....6 stages - 122 NMAD....6 stages
 - 152 NMD....6 stages - 152 NMAD....5 stages
 - 202 NMD....4 stages - 202 NMAD....3 stages
 - 252 NMD....3 stages



The maximum speed is shown on the pump nameplate.

3.2 Nomenclature

Characteristics shown on the nameplate fixed on the pump are as shown below:

Each pump is supplied with the following nameplate:

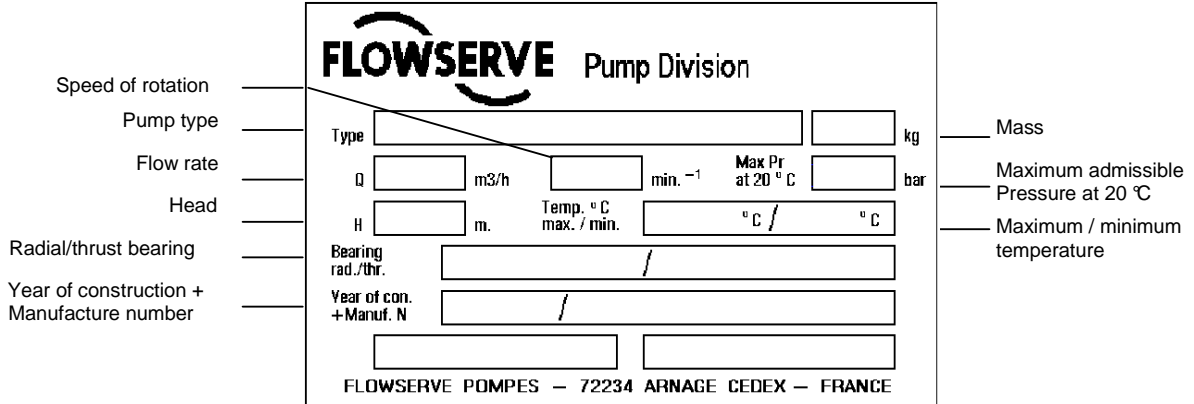

Each pump unit is supplied with the following nameplate:

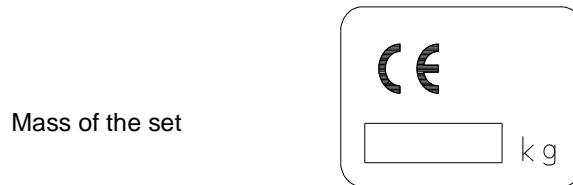

4 INSTALLATION



Equipment operated in hazardous locations must comply with the relevant explosion protection regulations. See section 1.6.4, *Products used in potentially explosive atmospheres*.



The condition of minimum submergence must be respected. Level control shall be fitted in the sump to prevent liquid level dropping below minimum acceptable.



All equipment must be grounded.

4.1 Location

The pump should be located to allow room for access, ventilation, maintenance and inspection with ample headroom for lifting and should be as close as practicable to the supply of liquid to be pumped.

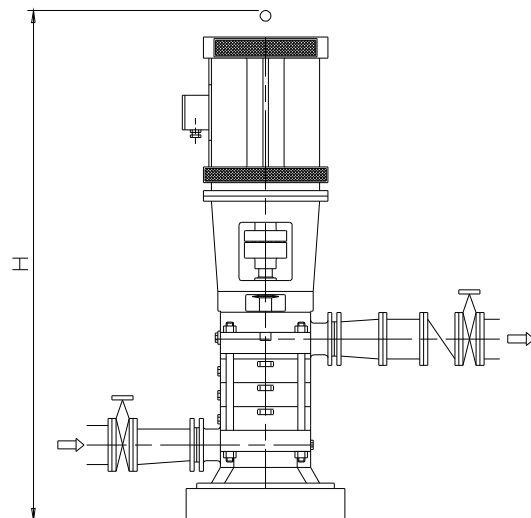

4.2 Foundation



There are many methods of installing pump units to their foundations. The correct method depends on the size of the pump unit, its location and noise vibration limitations. Non-compliance with the provision of correct foundation and installation may lead to failure of the pump and, as such, would be outside the terms of the warranty.

The base plate should be mounted onto a firm foundation, either an appropriate thickness of quality concrete or sturdy steel framework. It should NOT be distorted or pulled down onto the surface of the foundation, but should be supported to maintain the original alignment.

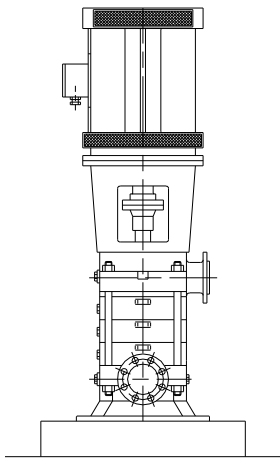

Anchor bolts must be appropriate for the foot bolt holes. Use anchor bolts of accepted standards and sufficient length so that they may be clamped safely in the grout.

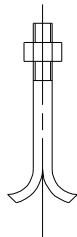

NF E 27 811

Provide sufficient space in the foundation to accommodate the anchor bolts. If necessary, provide concrete gullets.

4.2.1 Setting the base plate for anchoring

- Clean the foundation surface thoroughly.
- Put shims on the foundation surface (approx 20-25 mm thick), one on each side of the bolt hole (as an alternative, leveling screws can be used).

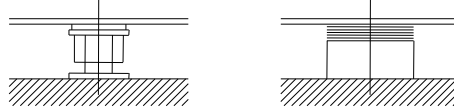

- Lay the base plate and level in both directions with extra shims. The base plate should be level to within 0.5 mm per 1 m.

4.2.2 Levelling

Pump without motor:

- Levelling on the motor stool with a levelling instrument
- Admissible tolerance 0.5 mm for 1 metre
- Wedge under the pump

Pump with motor:

- Levelling on the suction and discharge flange with a frame level
- Admissible tolerance 0.5 mm for 1 metre
- Wedge under the pump

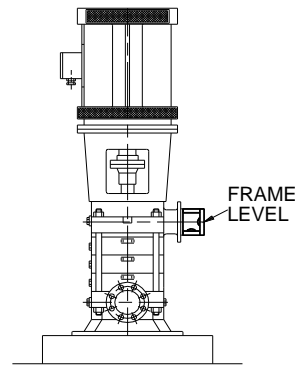
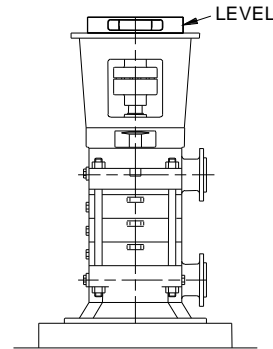

4.3 Initial alignment

CAUTION Before connecting the couplings verify the motor rotation direction.

4.3.1 Thermal expansion

CAUTION The pump and motor will normally have to be aligned at ambient temperature and should be corrected to allow for thermal expansion at operating temperature. In pump installations involving high liquid temperatures, the unit should be run at the actual operating temperature, shut down and the alignment checked immediately.

4.3.2 Alignment methods

DANGER Ensure pump and driver are isolated electrically and the half couplings are disconnected. Ensure that the pump pipework, suction and discharge, is disconnected.

CAUTION The alignment MUST be checked.

Although the pump will have been aligned at the factory it is most likely that this alignment will have been disturbed during transportation or handling. If necessary, align the motor to the pump, not the pump to the motor.

Alignment

Parallelism and concentricity check:

CAUTION Check the alignment at three or four points, before pipeworks assembly.

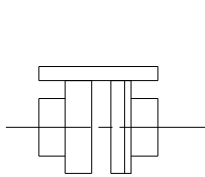

with a rule

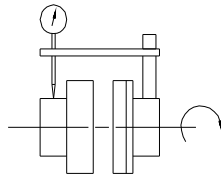

with a comparator

Admissible margin for a motor with roller bearings:
 = 0.15 mm parallel checking
 = 0.1 mm angular checking

Angular checking:

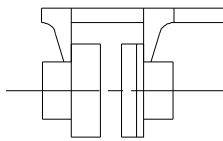

with a sliding rule

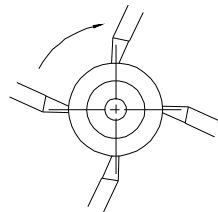

with a caliper gauge

CAUTION The alignment will be definitive only after pipework connection (see § 4.4.1).

DANGER Never connect the electric motor before the setting has been completely finished.

4.4 Piping

Ex The user must verify that the equipment is isolated from any external sources of vibration.

CAUTION Protective covers are fitted to the pipe connections to prevent foreign bodies entering during transportation and installation. Ensure that these covers are removed from the pump before connecting any pipes.

4.4.1 Suction and discharge pipework

The dimensions of the pipes do not directly depend on suction and discharge diameters of the pump:

- a) First, choose a flow speed < 2 m/s at suction, and about 3 m/s at discharge.
- b) Take into account the available NPSH, which must be superior to the required NPSH of the pump.

CAUTION Never use pump as a support for piping.

CAUTION Do not mount expansion joints in such a way that their force, due to internal pressure, may act on the pump flange.

Maximum forces and moments allowed on the pump flanges vary with the pump size and type. These external strains may cause misalignment, hot bearings, worn couplings, vibrations and the possible failure of the pump casing.

When designing the pipes (§ 4.4.2.1, § 4.4.2.2, § 4.4.3.1) take necessary precautions in order not to exceed maximum allowed strains.

Forces and moments applied to the pump flanges must never exceed the values shown in the table below:

Pipework arrangement	DN flanges	Forces (daN)				Moments (m.daN)			
		F _Y	F _Z	F _X	Σ F	M _Y	M _Z	M _X	Σ M
Suction and discharge	100	50	40	45	80	18	20	25	37
	125	62	55	55	100	22	26	31	46
	150	75	60	81	120	22	31	37	55
	200	100	81	90	157	34	39	48	72
	250	125	100	112	195	43	49	60	89
	300	150	121	135	235	65	74	91	134

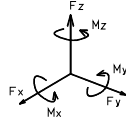
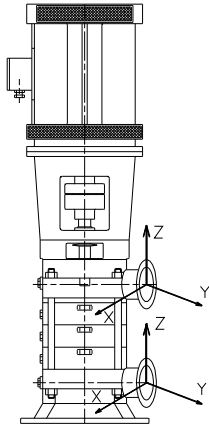

Ensure piping and fittings are flushed before use.



Ensure piping for hazardous liquids is arranged to allow pump flushing before removal of the pump.

4.4.2 Suction piping

4.4.2.1 Design of a flooded suction line

The suction line must be as short and direct as possible, never mount an elbow directly on the inlet flange of the pump.

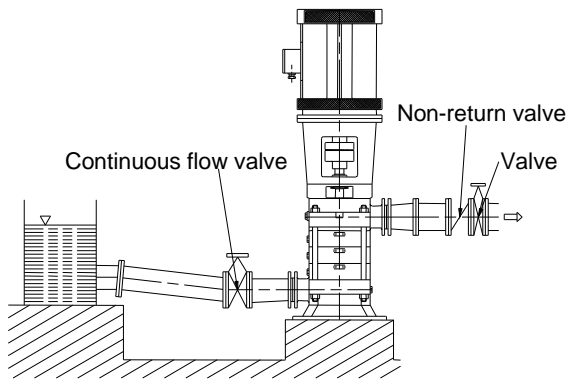

Flooded pump configuration

- Avoid sharp elbows or sudden narrowing. Use convergent $\leq 20^\circ$ (total angle).
- Arrange the pipework so that there are no air pockets (no bulges).
- If high points cannot be avoided in suction line, provide them with air relief cocks.
- If a strainer is necessary, its net area should be three or four times the area of the suction pipe.
- If an inlet valve is necessary, choose a model with direct crossing.



Do not tighten flanges before the final check (see § 4.4.4).

4.4.2.2 Design of a suction lift line

The inlet pipe must be as short and as direct as possible, never place an elbow directly on the pump inlet nozzle.

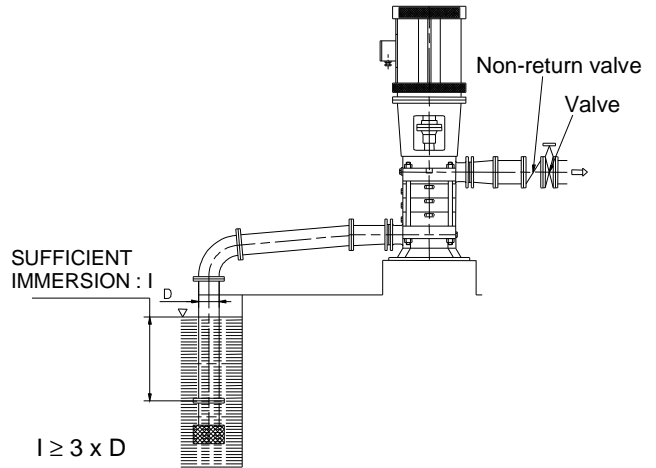

Sump suction configuration

- Avoid sharp elbows or sudden narrowings. Use convergents $\leq 20^\circ$ (total angle) with upright generating.
- Arrange that the suction pipework is inclined upwards towards the pump ensuring that there are no peaks.
- If a foot valve is necessary, do not oversize it because it would generate pulsations (valve beating).



Do not tighten flanges before the final check (see § 4.4.4).

4.4.3 Discharge piping

4.4.3.1 Design of a discharge line

- If discharge line is provided with a divergent, its total angle will be between 7° and 12° .
- Install the discharge valve after the non-return valve downstream.
- The non-return valve will be set in the discharge pipe to protect the pump from any excessive pressure surge and from reverse rotation.

If necessary, a control manometer can be connected on the pipework.

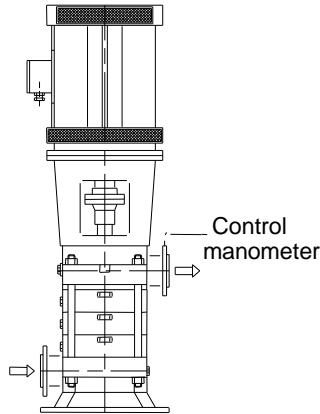

CAUTION Do not tighten flanges before the final check (see § 4.4.4).

4.4.4 Final checks

- a) Check the tightening of anchor bolts. Tighten them if necessary.
- b) Check that protective covers on suction and discharge flanges are removed.
- c) Check that holes of pipework flanges are parallel and correspond to those of the pump.
- d) Tighten suction and discharge flanges.

4.5 Electrical connections

DANGER Electrical connections must be made by a qualified Electrician in accordance with relevant local national and international regulations. This includes any grounding.

Ex It is important to be aware of the EUROPEAN DIRECTIVE on potentially explosive areas where compliance with IEC60079-14 is an additional requirement for making electrical connections.

Ex Avoid mechanical, hydraulic or electrical overload by using motor overload trips or a power monitor and make routine vibration monitoring.

! It is important to be aware of the EUROPEAN DIRECTIVE on electromagnetic compatibility when wiring up and installing equipment on site. Attention must be paid to ensure that the techniques used during wiring/installation do not increase electromagnetic emissions or decrease the electromagnetic immunity of the equipment, wiring or any connected devices. If in any doubt, contact Flowserve for advice.

DANGER The motor must be wired up in accordance with the motor manufacturer's instructions (normally supplied within the terminal box) including any temperature, earth leakage, current and other protective devices as appropriate.

The identification nameplate should be checked to ensure the power supply is appropriate.

A device to provide emergency stopping shall be fitted.

Carry out the ground connections according to the current local regulations.

CAUTION To avoid any risk of jamming, the direction of rotation will be checked after priming of the pump (§ 5.3.1, 5.3.2) and before the first start (§ 5.4.2).

4.6 Final shaft alignment check

- a) Check the alignment pump-motor according to the procedure § 4.3.2. Rectify if necessary by adjusting the motor only.
- b) Check by hand that the pump turns freely. A binding indicates a distortion of the pump, which is due to excessive pipes strains. If necessary the pipework design must be re-examined.
- c) If it provided, connect auxiliary pipe systems (hydraulic, pneumatic, sealing system).
- d) Control tightness and functionality of auxiliary piping.

4.7 Protection systems

Ex The following protection systems are recommended particularly if the pump is installed in a potentially explosive area or is handling a hazardous liquid. If in doubt consult Flowserve. If there is any possibility of the system allowing the pump to run against a closed valve or below minimum continuous safe flow a protection device should be installed to ensure the temperature of the liquid does not rise to an unsafe level.

If there are any circumstances in which the system can allow the pump to run dry, or start up empty, a power monitor should be fitted to stop the pump or prevent it from being started. This is particularly relevant if the pump is handling a flammable liquid.

If leakage of product from the pump or its associated sealing system can cause a hazard it is recommended that an appropriate leakage detection system is installed.

To prevent excessive surface temperatures at bearings it is recommended that temperature or vibration monitoring are carried out. See sections 5.5.4 and 5.5.5.

If a defect of cooling can lead to temperature higher than those acceptable a system of cooling surveillance must be installed.

Except when explicitly required by the customer in the specifications, when a possibility of reverse rotation exists the customer must install a reverse rotation protection device.

The customer must install all equipment required to avoid water hammer.

5 COMMISSIONING, START-UP, OPERATION AND SHUTDOWN

These operations must be carried out by fully qualified personnel.

5.1 Direction of rotation

CAUTION Starting or operating pumps with the wrong direction of rotation can be harmful to the pumps. Ensure that the pump rotation is the same as the arrow on the pump casing. It is preferable to check the direction of rotation before installing the coupling. If not, the pump must be filled in with the liquid before start-up.

CAUTION If maintenance work has been carried out to the site's electricity supply, the direction of rotation should be re-checked as above in case the supply phasing has been altered.

5.2 Guarding

Guarding is supplied fitted to the pump set.

If this has been removed or disturbed ensure that all the protective guards around the pump coupling and exposed parts of the shaft are securely fixed.

5.3 Priming and auxiliary supplies

Where there is any risk of the pump being run against a closed valve generating high liquid and casing external surface temperatures it is recommended that users fit an external surface temperature protection device.

CAUTION Ensure all electrical, hydraulic, pneumatic, sealant and lubrication systems (as applicable) are connected and operational.

CAUTION Ensure the inlet pipe and pump casing are completely full of liquid before starting continuous duty operation.

These operations must be carried out by personnel with approved qualifications.

5.3.1 Priming of a flooded pump

- a) As discharge valve is closed, fill the pump by opening the valve at suction. Let air escape by removing the plugs located on the pump.
- b) If the discharge pipe is headed and there is a by-pass valve on the non-return valve, open slightly the discharge valve and the by-pass of the non-return valve.
- c) When the pump is totally free of air bubbles, replace the plugs.

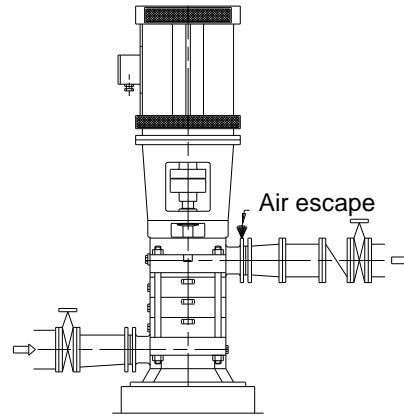

Priming of a flooded pump

5.3.2 Priming of a sump suction pump

* With foot valve:

- a) Fill suction pipe and casing with liquid from an independent source (pressure 1 to 2 bars).
- b) Let air escape by removing the plugs located on the pump.
- c) When the pump is totally free of air bubbles, replace the plugs.

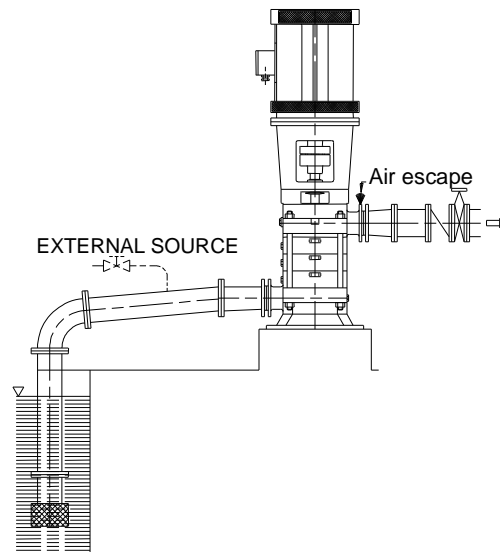

Priming of a sump suction pump with foot valve

Without foot valve:

Priming may be accomplished by means of venting system.

Note: Foot valves are not recommended when the pumped liquid has suspended solid particles. They may lodge between foot valve seat and shutter.

5.4 Starting the pump

5.4.1 Bring controls and preparation before the first starting and after each service call

Necessarily:

- a) Check the tightening of the different plugs.
- b) Check that the gland lightly tightens the packing rings.
- c) Risk of seal ring overheating.
- d) Check the direction of rotation of the motor. Refer to the rotation arrow of the pump.
- e) Install all protection systems and more particularly the coupling guard [7450] and the shield grid [9331] of the bearing.
- f) Open all suction valves (if existing).
- g) Close the outlet valve and the bypass valve.
- h) Ensure inlet pipe and pump casing are completely full of liquid.

5.4.2 First pump start-up

Suction valves must be fully open when pump is running. Never run the pump dry, it will cause damage.

- a) Start motor and check outlet pressure.
- b) If pressure is satisfactory, slowly OPEN outlet valve.
- c) Do not run the pump with the outlet valve closed for a period longer than 30 seconds.
- d) If NO pressure, or LOW pressure, STOP the pump. Refer to faultfinding chart for fault diagnosis.

The pump should run smoothly and without vibration.

The pump must never run at a capacity less than 10 % (for 102-122-152-202 NMD or NMAD and for 252 NMD) of the capacity at the best efficiency point.

Never remove a plug when the pump is running.

5.5 Running the pump

5.5.1 Venting the pump

Vent the pump to enable all trapped air to escape taking due care with hot or hazardous liquids.

Under normal operating conditions, after the pump has been fully primed and vented, it should be unnecessary to re-vent the pump.

5.5.2 Pump fitted with a stuffing box

If the pump has a packed gland there must be some leakage from the gland. Gland nuts should initially be finger tight only. Leakage should take place soon after the stuffing box is pressurized. If no leakage takes place the packing will begin to overheat. If overheating takes place the pump should be stopped and allowed to cool before being restarted. When the pump is restarted it should be checked to ensure leakage is taking place at the packed gland.

When adjusting an operating stuffing box (shield grids removed for this operation) the operator must be very careful. Safety gloves are compulsory and loose clothes are not allowed (above all to the arms) to avoid being caught by the pump shaft.

The pump should be run for ten minutes with steady leakage and the gland nuts tightened by 10 degrees at a time until leakage is reduced to an acceptable level. The temperature of the gland should be checked after each round of tightening. If the temperature starts to climb rapidly then back off the gland nuts until the temperature drops down. Wait for the temperature to stabilize before tightening again. The leakage must not be reduced below a rate of 20 drops per minute. Bedding in of the packing may take several hours.

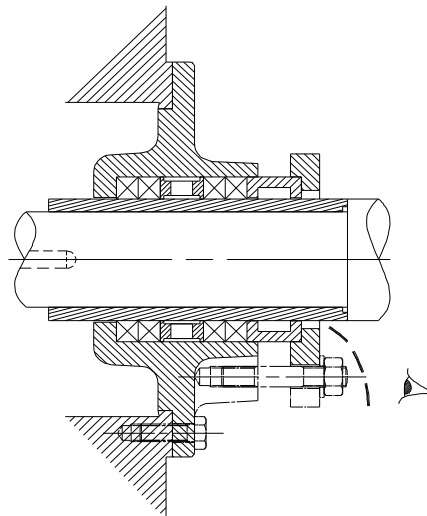

! Shield grids being removed during installation of the gland packing, it must be ensured that they are replaced as soon as this operation is completed.

If hot liquids are pumped ($105\text{ °C} < t \leq 140\text{ °C}$), the stuffing box includes a thermal barrier to avoid evaporation in the packing zone, which would quickly destroy the gland packing. As leakages are reduced and the cooling is made more efficient (flow and temperature of cooling water), it is observed that the packing gland will last longer.

5.5.3 Pump fitted with mechanical seal

A mechanical seal ensures a seal without leakage and does not need any adjustment. Nevertheless if a light leakage occurs during start-up, it should disappear after the initial running in of the friction faces.

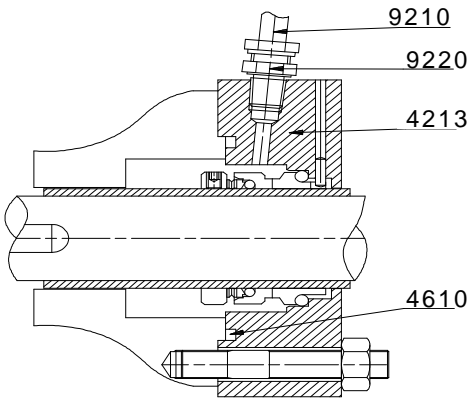

Simple mechanical seal

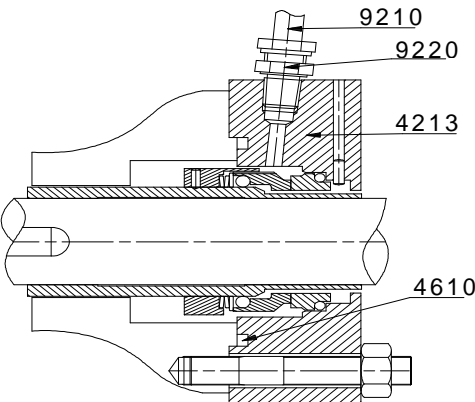

Balanced mechanical seal

! **CAUTION** NEVER RUN A MECHANICAL SEAL DRY, EVEN FOR A SHORT WHILE.

SAFETY INSTRUCTIONS WHEN THE PUMP IS RUNNING:

! If hot or freezing components of the machine can present a danger to operators, they must be shielded to avoid accidental contact. If a 100 % protection is not possible, the machine access must be confined to the maintenance staff only.

! If the temperature is greater than 80 °C, a warning plate must be clearly placed on the pump.

! The adjusting lines, the stuffing box, the lines under pressure or the mechanical seal cooling lines must be protected against external knocks.

! **DANGER** It is strictly forbidden to open switch cupboards, switch boxes, or all other live electric equipment. If it is necessary to open them in order to take readings, to carry out tests or adjustments for example, only a skilled technician may do them with adapted tools. Make sure that physical protections against electrical risks are used.

5.5.4 Bearings

Ex If the pumps are working in a potentially explosive atmosphere, temperature or vibration monitoring at the bearings is recommended. If bearing temperatures are to be monitored it is essential that a benchmark temperature is recorded at the commissioning stage and after the bearing temperature has stabilized.

- Record the bearing temperature (t) and the ambient temperature (ta)
- Estimate the likely maximum ambient temperature (tb)
- Set the alarm at $(t+tb-ta+5)\text{ °C}$ [$(t+tb-ta+10)\text{ °F}$] and the trip at 100 °C (212 °F) for oil lubrication and 105 °C (220 °F) for grease lubrication

It is important, particularly with grease lubrication, to keep a check on bearing temperatures. After start up the temperature rise should be gradual, reaching a maximum after approximately 1.5 to 2 hours. This temperature rise should then remain constant or marginally reduce with time.

5.5.5 Normal vibration levels, alarm and trip

For guidance, pumps generally fall under a classification for rigid support machines within the International rotating machinery standards and the recommended maximum levels below are based on those standards.



Alarm and trip values for installed pumps should be based on the actual measurements (N) taken on site on the bearing housings of the pump in the fully commissioned as new condition.

The example (N) value is given for the preferred operating flow region (typically this may extend to 70 to 120 % of the pump best efficiency point); outside the preferred flow region the actual vibration experienced may be multiplied by up to 2.

These standard values can vary with the rotational speed and the power absorbed by the pump. For any special case, do not hesitate to consult us.

Measuring vibration at regular intervals will then show any deterioration in pump or system operating conditions.

Vibration Velocity - unfiltered		Horizontal Configuration mm/s (in./s) r.m.s.	Vertical Configuration mm/s (in./s) r.m.s.
Normal	N	≤ 5.6 (0.22)	≤ 7.1 (0.28)
Alarm	N x 1.25	≤ 7.1 (0.28)	≤ 9.0 (0.35)
Shutdown Trip	N x 2.0	≤ 11.2 (0.44)	≤ 14.2 (0.56)

5.5.6 Stop/start frequency

Pump sets are normally suitable for the number of equally spaced stop/starts per hour shown in the table below. Check actual capability of the driver and control/starting system before commissioning.

Motor rating kW (hp)	Maximum stop/starts per hour
Up to 15 (20)	15
Between 15 (20) and 90 (120)	10
90 (120) to 150 (200)	6
Above 150 (200)	Refer

Where duty and standby pumps are installed it is recommended that they are run alternately every week.

5.6 Stopping and shutdown

5.6.1 Stopping and restarting in continuous running

According to hydraulic conditions of the installation and its automation degree, stop and restart procedures can have different forms. Nevertheless all of them must respect imperatively the following rules:

Stopping:

- a) Avoid that the unit turns in the opposite direction to the normal running.
- b) Make sure that the discharge line pressure does not reach the foot valve.
- c) Avoid a continuous running below the authorized flow rate (see § 5.4.2).

Restart:

- a) Ensure that the pump is completely full of liquid.
- b) Ensure a continuous supply with a sufficient available NPSH.
- c) Ensure a backpressure so that the motor power is not in excess.

d) Respect the starting frequency imposed by the motor manufacturer.

e) Protect the pump against water hammer when stopping or starting.

Shutdown:

Close the outlet valve and stop the motor. Eventually close the inlet valve.

For prolonged shutdowns and especially when ambient temperatures are likely to drop below freezing point, the pump and any cooling and flushing arrangements must be drained or otherwise protected.

5.7 Hydraulic, mechanical and electrical duty

This product has been supplied to meet the performance specifications of your purchase order, however it is understood that during the life of the product these may change. The following notes may help the user decide how to evaluate the implications of any change. If in doubt contact your nearest Flowserve office.

5.7.1 Specific gravity (SG)

Pump capacity and total head in meters (feet) do not change with SG, however pressure displayed on a pressure gauge is directly proportional to SG. Power absorbed is also directly proportional to SG. It is therefore important to check that any change in SG will not overload the pump driver or over-pressurize the pump.

5.7.2 Viscosity

For a given flow rate the total head reduces with increased viscosity and increases with reduced viscosity. Also for a given flow rate the power absorbed increases with increased viscosity, and reduces with reduced viscosity. It is important that checks are made with your nearest Flowserve office if changes in viscosity are planned.

5.7.3 Pump speed

Changing pump speed effects flow, total head, power absorbed, NPSH_R, noise and vibration. Flow varies in direct proportion to pump speed, head varies as speed ratio squared and power varies as speed ratio cubed. The new duty, however, will also be dependent on the system curve. If increasing the speed, it is important therefore to ensure the maximum pump working pressure is not exceeded, the driver is not overloaded, NPSH_A > NPSH_R, and that noise and vibration are within local requirements and regulations.

5.7.4 Net positive suction head (NPSH_A)

NPSH available (NPSH_A) is the head available at the impeller inlet, above the vapour pressure of the pumped liquid.

NPSH required (NPSH_R) is the minimum head required at the impeller inlet, above the vapour pressure of the pumped liquid, to avoid excessive cavitation and extreme performance degradation.

It is important that NPSH_A > NPSH_R. The margin between NPSH_A > NPSH_R should be as large as possible.

If any change in NPSH_A is proposed, ensure these margins are not significantly eroded. Refer to the pump performance curve to determine exact requirements particularly if flow has changed. If in doubt please consult your nearest Flowserve office for advice and details of the minimum allowable margin for your application.

5.7.5 Pumped flow

Flow must not fall outside the minimum and maximum continuous safe flow shown on the pump performance curve and or data sheet.

5.8 Pumps for Food Use or Potable Water

If the pump has not been specifically ordered for a food or drinking water application it must not be used for these types of applications. If it has been ordered for this type of application the following recommendations are to be followed.

5.8.1 Cleaning prior to operation

Pumps that are to be used for a food or drinking water application should be cleaned before being put into initial operation and after the installation of spare parts that are in contact with the liquid.

Cleaning once the pump has been commissioned will depend on the application and operating conditions. The user must ensure that the cleaning procedures are suitable for the application and operating conditions, and local regulations.

6 MAINTENANCE

6.1 General

 If a belt drive is used, the assembly and tension of the belts must be verified during regular maintenance procedure.

 In dirty or dusty environments, regular checks must be made and dirt removed from areas around close clearances, bearing housings and motors.

 It is the plant operator's responsibility to ensure that all maintenance, inspection and assembly work is carried out by authorized and qualified personnel who have adequately familiarized themselves with the subject matter by studying this manual in detail (see also section 1.6.2).

Any work on the machine must be performed when it is at a standstill. It is imperative that the procedure for shutting down the machine is followed, as described in section 5.6.

On completion of work all guards and safety devices must be re-installed and made operative again. Before restarting the machine, the relevant instructions listed in section 5, *Commissioning, start up, operation and shut down* must be observed.

Oil and grease leaks may make the ground slippery. Machine maintenance must always begin and finish by cleaning the ground and the exterior of the machine.

If platforms, stairs and guardrails are required for maintenance, they must be placed for easy access to areas where maintenance and inspection are to be carried out. The positioning of these accessories must not limit access or hinder the lifting of the part to be serviced.

When air or compressed inert gas is used in the maintenance process, the operator and anyone in the vicinity must be careful and have the appropriate protection. DO NOT SPRAY air or compressed inert gas on skin. DO NOT DIRECT an air or gas jet towards other people. Never use air or compressed inert gas to clean clothes.

Before working on the pump, take measures to prevent an uncontrolled start. Put a warning board on the starting device with the words:

"Machine under repair: do not start".

With electric drive equipment, lock the main switch open and withdraw any fuses. Put a warning board on the fuse box or main switch with the words:

"Machine under repair: do not connect".

Never clean equipment with inflammable solvents or carbon tetrachloride. Protect yourself against toxic fumes when using cleaning agents.

6.2 Maintenance schedule



It is recommended that a maintenance plan and schedule is adopted, in line with these User Instructions. It should include the following:

- a) The pump must be completely vented and drained and rendered inert before any disassembly operation.
- b) Any auxiliary systems installed must be monitored, if necessary, to ensure they function correctly.
- c) During cleaning of the pump ensure the compatibility between the cleaning products and the gaskets.
- d) Verify the condition of the gaskets.
- e) Gland packings must be adjusted correctly to give visible leakage and concentric alignment of the gland follower to prevent excessive temperature of the packing or follower. Mechanical seals should present no leakage.
- f) Check for any leaks from gaskets and seals. The correct functioning of the shaft seal must be checked regularly.
- g) Check bearing lubricant level, and if the hours run show a lubricant change is required.
- h) Check that the duty condition is in the safe operating range for the pump.
- i) Check vibration, noise level and surface temperature at the bearings to confirm satisfactory operation.
- j) Check the tightness of the connections.
- k) Check dirt and dust is removed from areas around close clearances, bearing housings and motors.
- l) Check coupling alignment and re-align if necessary.
- m) Verify the correct operation of the system.

The equipment used for maintenance and disassembly in an ATEX zone must be in conformity with the requirements zone.

Our specialist service personnel can help with preventative maintenance records and provide condition monitoring for temperature and vibration to identify the onset of potential problems.

If any problems are found the following sequence of actions should take place:

- a) Refer to section 7, *Faults; causes and remedies*, for fault diagnosis.
- b) Ensure equipment complies with the recommendations in this manual.
- c) Contact Flowserve if the problem persists.

6.2.1 Standard maintenance

Roller bearing

The bearings fitted are prepacked with grease at the factory. When the regreasing period is reached it is necessary to *remove* as much of the old grease as possible with a clean lint free cloth and repack the bearings with fresh grease.

Pump type	Lubrication Frequency *	Quantity (cm ³)
	1450 min ⁻¹	
102 NMD	8000	40
122 NMD	7000	30
152 NMD	6000	40
202 NMD	5500	60
252 NMD	5000	60

* At least once a year.

The grease used in factory for first filling is:

SHELL ALVANIA R2

Its equivalents: MOBIL : Mobilux EP 2,
TOTAL : Multis 2,
ELF : ELF MULTI

6.2.2 Routine inspection (daily/weekly)



The following checks should be made and the appropriate action taken to remedy any deviations:

- a) Check operating behavior. Ensure noise, vibration and bearing temperatures are normal.
- b) Check that there are no abnormal fluid or lubricant leaks (static and dynamic seals) and that any sealant systems (if fitted) are full and operating normally.
- c) Pump fitted with a stuffing box: leakage of 20 drops per minute.
- d) Pump fitted with a mechanical seal: no leakage.
- e) Check the level and condition of oil lubricant. On grease lubricated pumps, check running hours since last recharge of grease or complete grease change.

6.2.3 Periodic inspection (six monthly)



- a) Check foundation bolts for security of attachment and corrosion.
- b) Check pump-running records for hourly usage to determine if bearing lubricant requires changing.
- c) The coupling should be checked for correct alignment and worn driving elements.

Note: If a check shows a bad running of the motor pump unit, the user must:

- Refer to the "fault finding chart" chapter 7 of this leaflet to apply the recommended solutions.
- Ensure that your equipment corresponds to the arrangements of this leaflet.
- Contact FLOWSERVE after-sales Department if the problem persists.

6.2.4 Mechanical seals

The current maintenance is limited to seal control. It is necessary to detect any small leakage which announces the beginning of the deterioration of friction faces or secondary seal elements (rings, bellows, synthetic membranes). It is advisable to stop the pump as soon as possible. Have an approved seal vendor replace or repair the seal.

6.2.5 Gland packing

6.2.5.1 Pump fitted with a packed gland

A well run in and correctly adjusted packing gland requires little maintenance. If, after some time, the leakage becomes too great, the gland should be tightened again in order to return these to a normal level.

If re-tightening is not possible, new packing must be installed

6.2.5.2 Gland packing inspection and removal

- Remove the shield guards
- Slide back the gland
- Remove the packing rings with an extractor designed for this purpose (including the lantern ring if it exists; note its position and its direction of rotation).
- Inspect the state of the sleeve surface; the presence of many marked grooves will indicate that it must be replaced.
- Carefully clean the different pieces of the packing gland.

6.2.5.3 Gland packing fitting

If the packing is supplied as cord the packing must be cut so that the external diameter is lightly tightened and there is an initial gap between the sleeve and the packing ring.

For that purpose, wind the packing helically around the shaft sleeve or a chuck of the same diameter. (Take precautions to avoid damaging sleeve)

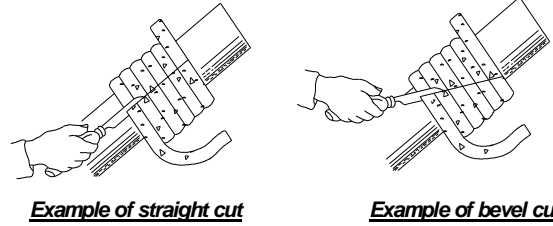

Example of straight cut

Example of bevel cut

CAUTION Ensure a tightening on the stuffing box housing and not on the sleeve.

SETTING OF PACKING

Follow the instructions:

- Assemble of the packing in S.
- Stagger by about 90° between two rings.
- Assemble packing after packing.

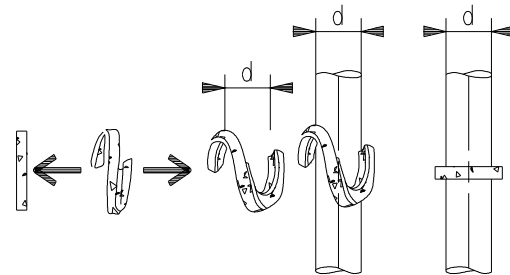

After setting the last packing ring, secure the packing with the gland and tighten the nut by hand.

After tightening, the shaft should turn by hand as easily as before the setting of the packing.

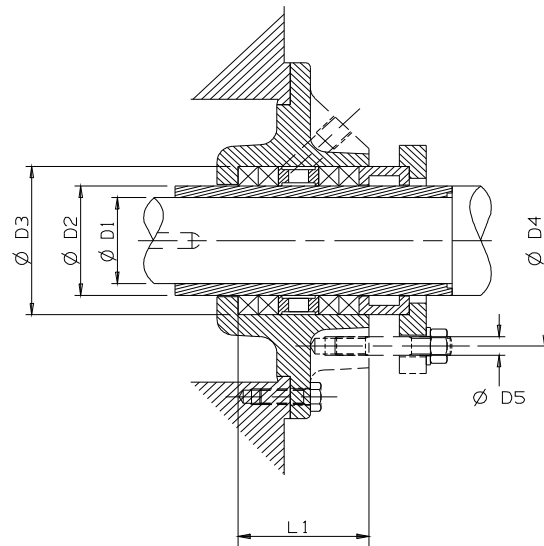

PUMP	DIMENSIONS IN MILLIMETERS						PACKING	
	D1	D2	D3	D4	D5	L1	Lgh	□
102 NMD – 102 NMAD	45	55	75	100	M12	45	205	10
122 NMD - 122 NMAD	55	70	95	135	M12	78	260	12
152 NMD - 152 NMAD	65	80	109	150	M16	91	297	14
202 NMD - 202 NMAD	75	100	132	180	M16	104	365	16
252 NMD	75	100	132	180	M16	104	365	16

6.2.6 Internal coating

If the pump has an internal coating, this coating must be inspected periodically. Any wear or cracks of the coating found must be immediately repaired. Failure to do this may lead to accelerated wear of the coating during operation and corrosion of the exposed base metal, depending on the material and pumped liquid. Special attention must be paid to the coating edges. Any loss of coating material is considered to be normal wear and tear on the pump and is not considered as warranty. Flowserve has applied the coatings according to the supplier's instructions but will not be held responsible for coating wear or cracks that may develop over time.

6.3 Spare parts

6.3.1 Ordering of spares

Flowserve keeps records of all pumps that have been supplied. When ordering spares the following information should be quoted:

- 1) Pump serial number.
- 2) Pump size.
- 3) Part name
- 4) Part number
- 5) Number of parts required.

The pump size and serial number are shown on the pump nameplate.

To ensure continued satisfactory operation, replacement parts to the original design specification should be obtained from Flowserve. Any change to the original design specification (modification or use of a non-standard part) will invalidate the pump's safety certification.

6.3.2 Storage of spares

Spares should be stored in a clean dry area away from vibration. Inspection and re-treatment of metallic surfaces (if necessary) with preservative are recommended at 6 monthly intervals.

6.4 Recommended spares and consumable items

[2250] - [4130] - [4590-01] – [4590-02]- [4610-01] - [4610-02] - [4610-03] - [4610-04] - [3011] - [3300] - [3400]

- a) Destroy all the gaskets after dismantling, replace them when reassembling.



b) **IT IS RECOMMENDED THAT BEARINGS ARE NOT REUSED AFTER ANY REMOVAL FROM THE SHAFT.**

- c) After serving during two years, replace the gland packing.

6.5 Disassembly



Refer to section 1.6, *Safety*, and section 6 *Maintenance*, before dismantling the pump.



Before dismantling the pump for overhaul, ensure genuine Flowserve replacement parts are available. Refer to sectional drawings for part numbers and identification.

REPAIR OF THE PUMP



If the pump presents abnormalities or a persistent malfunction, contact immediately:

FLOWSERVE

After-sales Service

**Tel.: 02 43 40 57 57
(33) 2 43 40 57 57
Fax.: 02 43 40 58 17
(33) 2 43 40 58 17**

According to the After-sales Service instructions, disassembly will be limited to the dismantling of the pump.

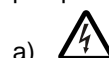

a) **DISCONNECT THE UNIT FROM POWER.**

- b) Close the inlet valve (if fitted) and outlet valve.
- c) Wait for the moment when the pump casing is cooled and at ambient temperature.

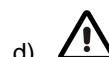

d) **DRAIN PUMP.**

- e) Dismantle inlet and outlet pipeworks as well as all pipeworks.



f) **REMOVE PUMP TAKING INTO ACCOUNT SAFETY (§ 1) AND HANDLING (§ 3) PROCEDURES.**



ANY DISASSEMBLY, REPAIR OR REASSEMBLY WILL BE CARRIED OUT UNDER FLOWSERVE' RESPONSABILITY, EITHER DIRECTLY BY THE AFTER-SALES SERVICE OR BY OTHER FLOWSERVE-AGENTS WHO WILL GET THE REQUIRED INSTRUCTIONS AND APPROVALS. THIS IS THE CASE OF AUTHORIZED REPAIRERS WHOSE ADDRESSES AND TELEPHONE NUMBERS WILL BE GIVEN ON REQUEST.

7 FAULTS; CAUSES AND REMEDIES

					Insufficient flow rate	
					Irregular pump running	
					Driver overloaded	
					Mechanical seal leak	
					Equipment vibration	
					Excessive pump casing temperature	
					POSSIBLE CAUSES	
					SOLUTIONS	
●	●		●	●	Pump or suction pipe not completely filled	- Check and complete filling
●	●		●		Air bubbles in pipes	- Check and desecrate the pipes
●			●	●	Suction level too low	- Check: the available NPSH > the required NPSH - Reduce geometrical suction lift - Reduce head losses in pipes and in fittings (diameter increase and appropriate fitting positions) - Check valves and strainers - Check the immersion head of the suction valve
●			●		Wrong rotation	- Reverse 2 phases on motor terminal boxes
●	●	●			The motor is running on 2 phases only	- Check and control the motor electrical power supply
●					Motor running too low	- Check the connection in the terminal box according to the voltage
●			●		Total manometric head system higher than pump differential head	- Check the discharge head - Check the head losses in discharge pipes (partly closed valve, foreign particles, back pressure too high) - Modify the installation or change the pump set
	●		●		Total manometric head system lower than pump differential head	- Throttle at discharge valve or trim the impeller (contact our local agent): CONSULT FLOWSERVE
●			●	●	Pipes (valves, filter...)	- Control, dismantle and clean
			●	●	Insufficient flow rate	- Check the suction and discharge pipes (valves, back pressure)
●					Worn wear-ring surfaces	- Foresee pump mending. CONSULT FLOWSERVE
●	●	●	●		Seizure, jamming	- CONSULT FLOWSERVE
●	●	●	●		Excessive strains on flanges	- Check the flange connections and eliminate strains (pipe positioning or elastic sleeves mounting)
			●		Defective gland packing on the shaft	- Check and replace all the gland packing parts - Mechanical seal: CONSULT FLOWSERVE
●	●	●	●		Defective motor bearings	- CONSULT FLOWSERVE
	●			●	Specific gravity or viscosity of liquid too high	- Consult our local agent to analyse the problem
			●		Misalignment	- Check the alignment of the pump and of its driver
			●		Foundations not sufficiently rigid	- Check the setting of base plates: tightening, bad adjustment, seal

					Insufficient pressure	
					Pump looses prime after starting	
					POSSIBLE CAUSES	
					SOLUTIONS	
●					Rotation speed too low (check the driver)	- Check the connection in the terminal box according to the voltage
●	●				Presence of air	- Check and deaerate
●					Suction pressure insufficient	- Check: the available NPSH > the required NPSH
●					Mechanical defects	- CONSULT FLOWSERVE
●	●				Air leak in the suction pipe	- Check suction pipe is airtight
●	●				Restriction in suction pipe	- Check diameter of suction pipe
●					Suction level too low	- Check the NPSH >NPSH - Reduce geometrical suction lift - Reduce head losses in pipes and in fittings (diameter increase and appropriate fitting positions) - Check valves and strainers - Check the immersion head of the suction valve
●	●				Obstruction of suction pipe	- Check condition of pipe
●	●				Defective gland packing on the shaft	- Check and replace all the gland packing. - Mechanical seal: CONSULT FLOWSERVE
●					Defective gasket	- CONSULT FLOWSERVE

8 PARTS LIST AND DRAWINGS

8.1 Sectional drawings

8.1.1 102 NMD pumps

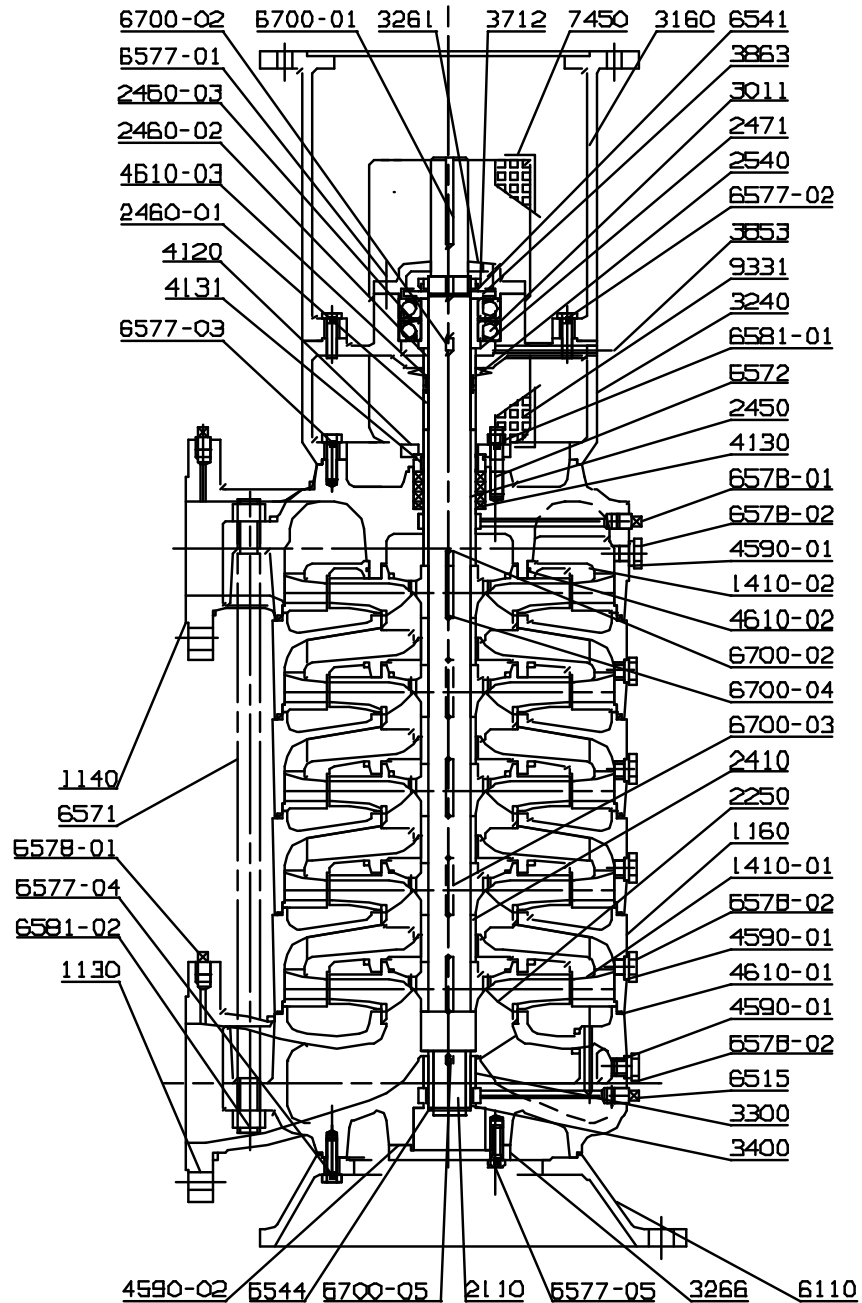

8.1.2 122 NMD pumps

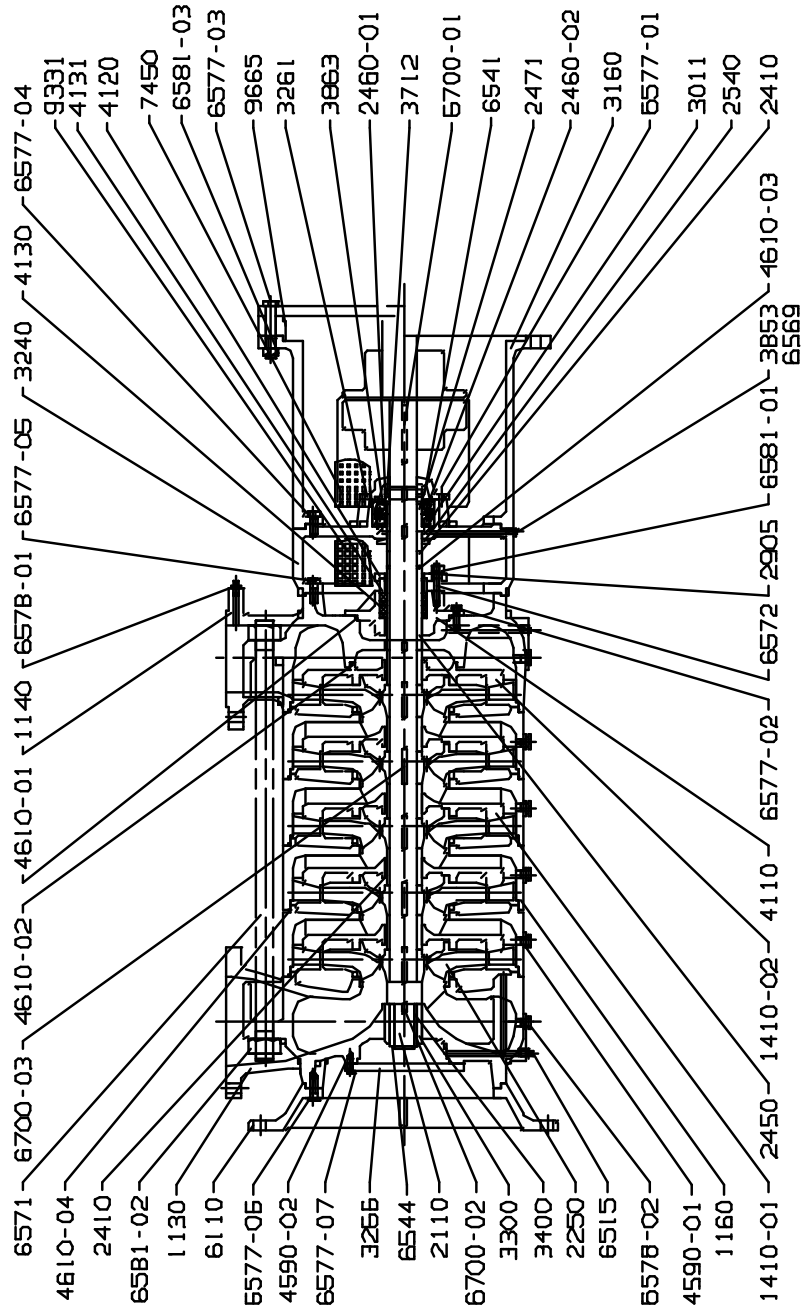

8.1.3 152 - 202 NMD pumps

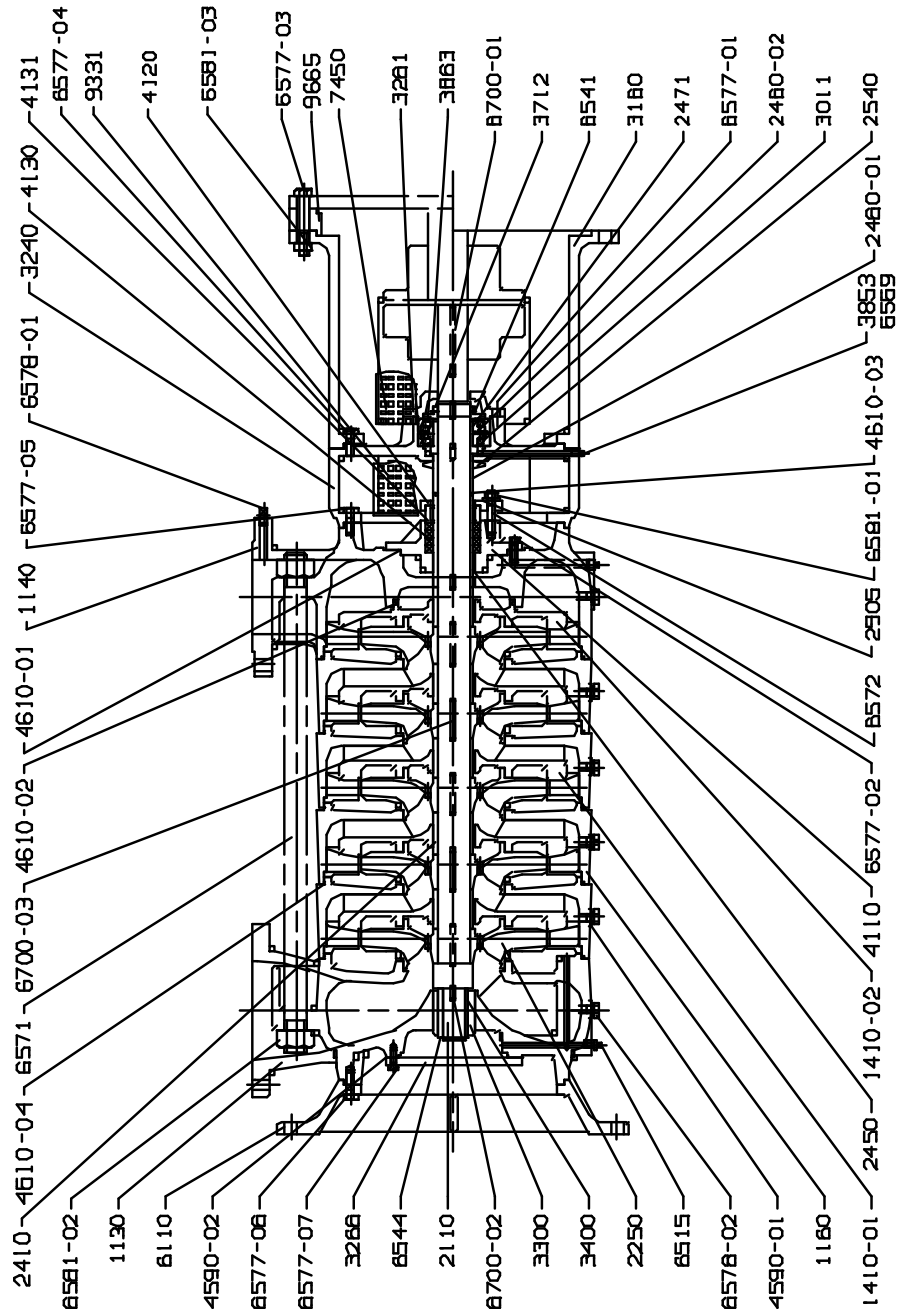

8.1.4 252 NMD pumps

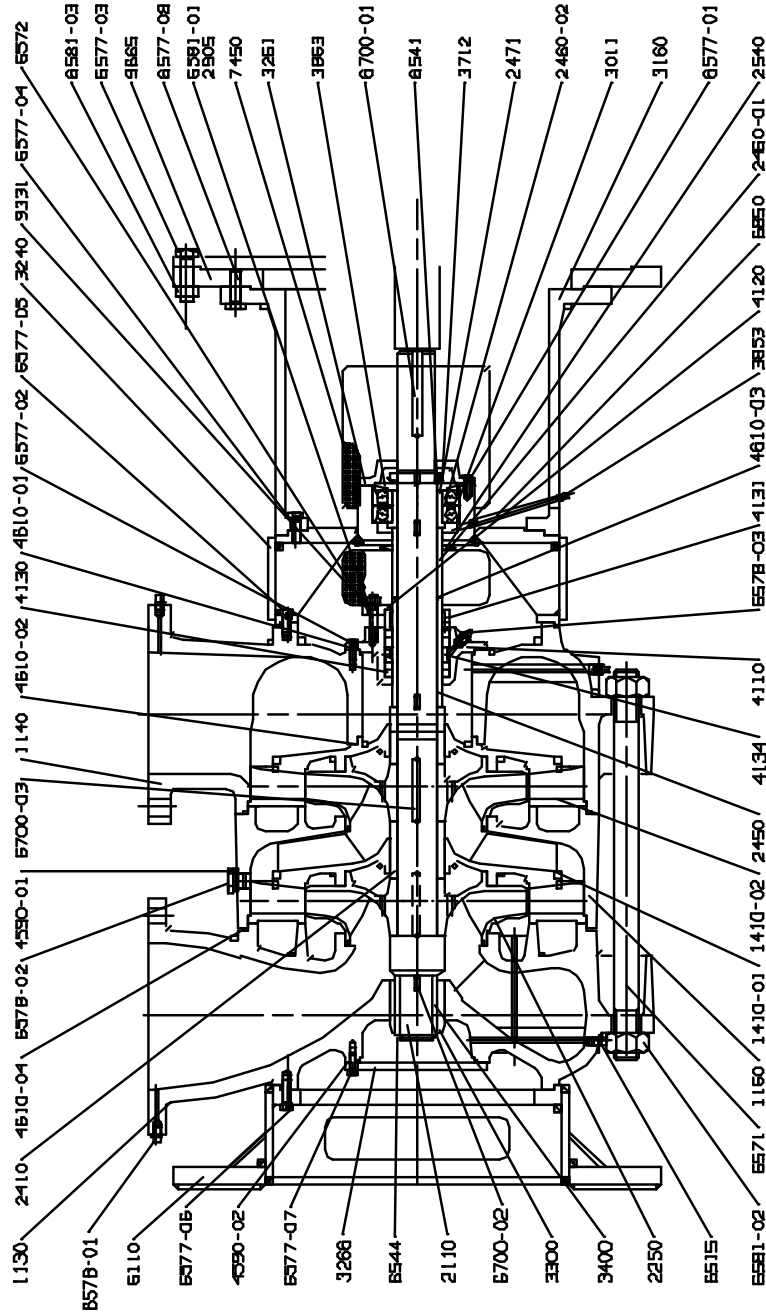

8.1.5 102 NMAD pumps

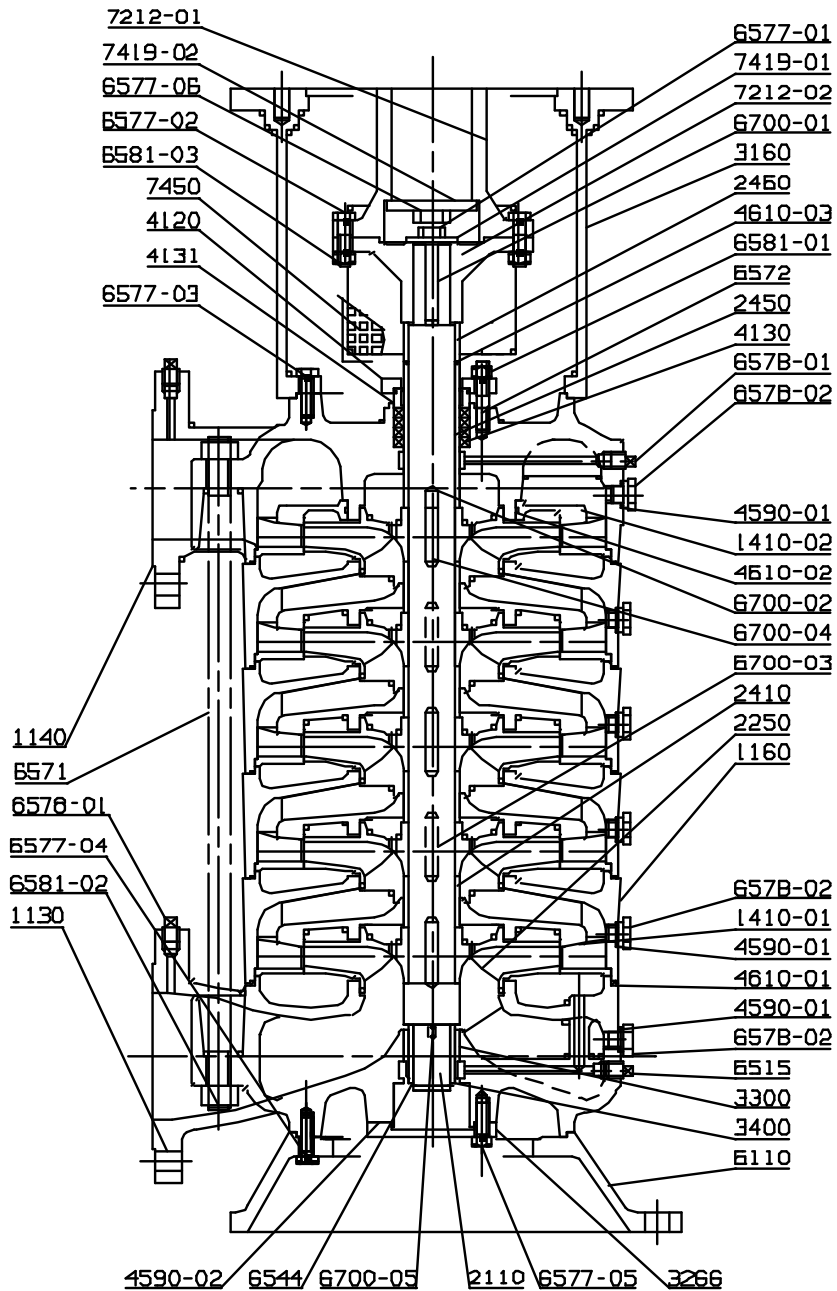

8.1.6 122 - 152 - 202 NMAD pumps

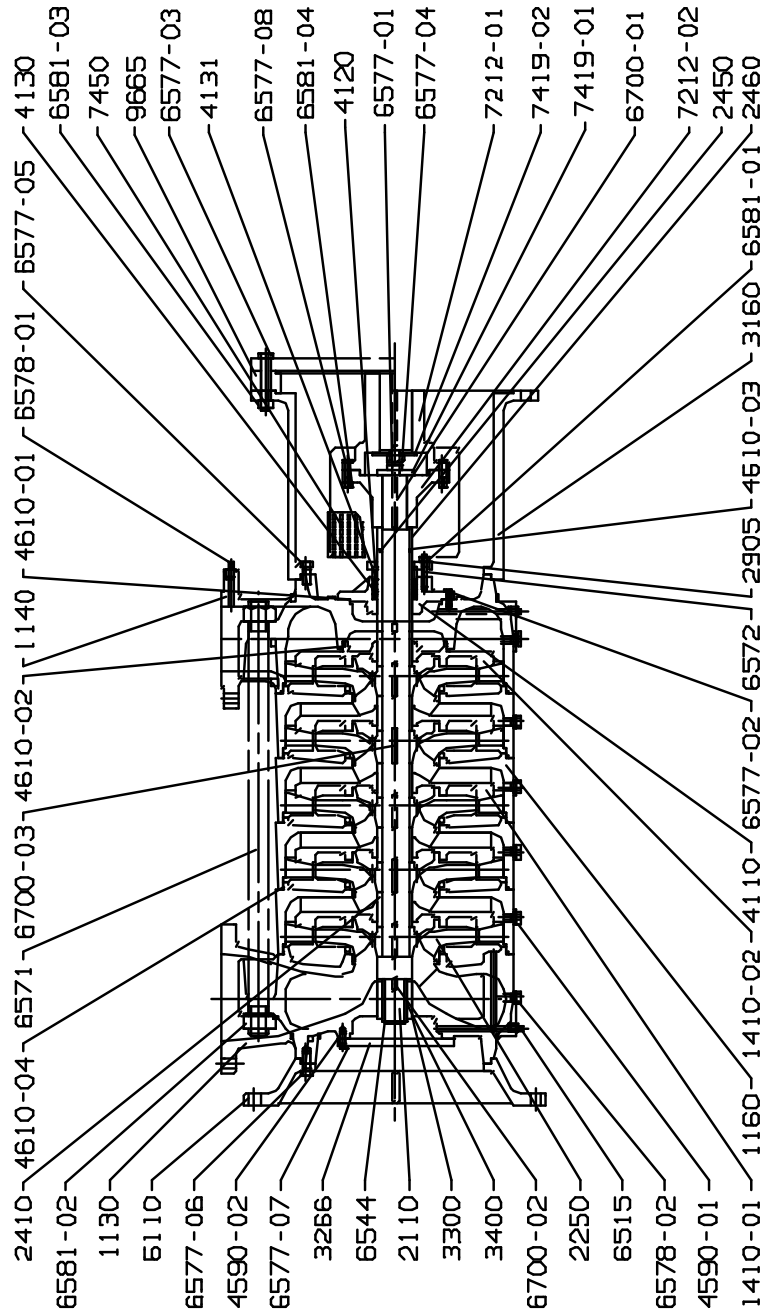

8.2 Sectional drawings part list

8.2.1 Parts list pumps 102 NMD

N	DESIGNATION	N	DESIGNATION
1130	Suction casing	4590-01	Gasket
1140	Discharge casing	4590-02	Gasket
1160	Stage casing	4610-01	Round section joint ring
1410-01	Diffuser	4610-02	Round section joint ring
1410-02	Diffuser, last stage	4610-03	Round section joint ring
2110	Pump shaft	6110	Baseplate
2250	Radial flow impeller shrouded	6115	Drain plug
2410	Interstage sleeve	6541	Lockwasher
2450	Shaft sleeve	6544	Circlip
2460-01	Spacer sleeve	6571	Tie bolt
2460-02	Spacer sleeve	6572	Stud
2460-03	Spacer sleeve	6577-01	Hexagon head bolt
2471	Inner race centring sleeve (bearing)	6577-02	Hexagon head bolt
2540	Thrower	6577-03	Hexagon head bolt
3011	Radial ball bearing	6577-04	Hexagon head bolt
3160	Motor stool	6577-05	Hexagon head bolt
3240	Bearing carrier	6578-01	Threaded plug
3261	Bearing cover	6578-02	Threaded plug
3266	Bearing end cover	6581-01	Hexagon nut
3300	Bearing bush	6581-02	Hexagon nut
3400	Bearing sleeve	6700-01	Key
3712	Bearing nut	6700-02	Key
3853	Grease nipple	6700-03	Key
3863	Grease regulator	6700-04	Key
4120	Stuffing box gland	6700-05	Key
4130	Gland packing	7450	Coupling guard
4131	Follower	9331	Cover plate

8.2.2 Parts list pumps 122 – 152 – 202 NMD

N	DESIGNATION	N	DESIGNATION
1130	Suction casing	4610-01	Round section joint ring
1140	Discharge casing	4610-02	Round section joint ring
1160	Stage casing	4610-03	Round section joint ring
1410-01	Diffuser	4610-04	Round section joint ring
1410-02	Diffuser, last stage	6110	Baseplate
2110	Pump shaft	6515	Drain plug
2250	Radial flow impeller shrouded	6541	Lockwasher
2410	Interstage sleeve	6544	Circlip
2450	Shaft sleeve	6569	Plug
2460-01	Spacer sleeve	6571	Tie bolt
2460-02	Spacer sleeve	6572	Stud
2471	Inner race centring sleeve (bearing)	6577-01	Hexagon head bolt
2540	Thrower	6577-02	Hexagon head bolt
2905	Washer	6577-03	Hexagon head bolt
3011	Radial ball bearing	6577-04	Hexagon head bolt
3160	Motor stool	6577-05	Hexagon head bolt
3240	Bearing carrier	6577-06	Hexagon head bolt
3261	Bearing cover	6577-07	Hexagon head bolt
3266	Bearing end cover	6578-01	Threaded plug
3300	Bearing bush	6578-02	Threaded plug
3400	Bearing sleeve	6581-01	Hexagon nut
3712	Bearing nut	6581-02	Hexagon nut
3853	Grease nipple	6581-03	Hexagon nut
3863	Grease regulator	6700-01	Key
4110	Stuffing box housing	6700-02	Key
4120	Stuffing box gland	6700-03	Key
4130	Gland packing	7450	Coupling guard
4131	Follower	9331	Cover plate
4590-01	Gasket	9665	Special flange
4590-02	Gasket		

8.2.3 Parts list pumps 252 NMD

N	DESIGNATION	N	DESIGNATION
1130	Suction casing	4610-01	Round section joint ring
1140	Discharge casing	4610-02	Round section joint ring
1160	Stage casing	4610-03	Round section joint ring
1410-01	Diffuser	4610-04	Round section joint ring
1410-02	Diffuser, last stage	6110	Baseplate
2110	Pump shaft	6515	Drain plug
2250	Radial flow impeller shrouded	6541	Lockwasher
2410	Interstage sleeve	6544	Circlip
2450	Shaft sleeve	6571	Tie bolt
2460-01	Spacer sleeve	6572	Stud
2460-02	Spacer sleeve	6577-01	Hexagon head bolt
2471	Inner race centring sleeve (bearing)	6577-02	Hexagon head bolt
2540	Thrower	6577-03	Hexagon head bolt
2905	Washer	6577-04	Hexagon head bolt
3011	Radial ball bearing	6577-05	Hexagon head bolt
3160	Motor stool	6577-06	Hexagon head bolt
3240	Bearing carrier	6577-07	Hexagon head bolt
3261	Bearing cover	6577-08	Hexagon head bolt
3266	Bearing end cover	6578-01	Threaded plug
3300	Bearing bush	6578-02	Threaded plug
3400	Bearing sleeve	6578-03	Threaded plug
3712	Bearing nut	6581-01	Hexagon nut
3853	Grease nipple	6581-02	Hexagon nut
3863	Grease regulator	6581-03	Hexagon nut
4110	Stuffing box housing	6700-01	Key
4120	Stuffing box gland	6700-02	Key
4130	Gland packing	6700-03	Key
4131	Follower	6850	Pipe coupling
4134	Lantern ring	7450	Coupling guard
4590-01	Gasket	9331	Cover plate
4590-02	Gasket	9665	Special flange

8.2.4 Parts list pumps 102 NMAD

N	DESIGNATION	N	DESIGNATION
1130	Suction casing	6571	Tie bolt
1140	Discharge casing	6572	Stud
1160	Stage casing	6577-01	Hexagon head bolt
1410-01	Diffuser	6577-02	Hexagon head bolt
1410-02	Diffuser, last stage	6577-03	Hexagon head bolt
2110	Pump shaft	6577-04	Hexagon head bolt
2250	Radial flow impeller shrouded	6577-05	Hexagon head bolt
2410	Interstage sleeve	6577-06	Hexagon head bolt
2450	Shaft sleeve	6578-01	Threaded plug
2460	Spacer sleeve	6578-02	Threaded plug
3160	Motor stool	6581-01	Hexagon nut
3266	Bearing end cover	6581-02	Hexagon nut
3300	Bearing bush	6581-03	Hexagon nut
3400	Bearing sleeve	6700-01	Key
4120	Stuffing box gland	6700-02	Key
4130	Gland packing	6700-03	Key
4131	Follower	6700-04	Key
4590-01	Gasket	6700-05	Key
4590-02	Gasket	7212-01	Half coupling rigid
4610-01	Round section joint ring	7212-02	Half coupling rigid
4610-02	Round section joint ring	7419-01	Coupling lock nut
4610-03	Round section joint ring	7419-02	Coupling lock nut
6110	Baseplate	7450	Coupling guard
6544	Circlip		

8.2.5 Parts list pumps 122 – 152 – 202 NMAD

N	DESIGNATION	N	DESIGNATION
1130	Suction casing	6544	Circlip
1140	Discharge casing	6571	Tie bolt
1160	Stage casing	6572	Stud
1410-01	Diffuser	6577-01	Hexagon head bolt
1410-02	Diffuser, last stage	6577-02	Hexagon head bolt
2110	Pump shaft	6577-03	Hexagon head bolt
2250	Radial flow impeller shrouded	6577-04	Hexagon head bolt
2410	Interstage sleeve	6577-05	Hexagon head bolt
2450	Shaft sleeve	6577-06	Hexagon head bolt
2460	Spacer sleeve	6577-07	Hexagon head bolt
2905	Washer	6577-08	Hexagon head bolt
3160	Motor stool	6578-01	Threaded plug
3266	Bearing end cover	6578-02	Threaded plug
3300	Bearing bush	6581-01	Hexagon nut
3400	Bearing sleeve	6581-02	Hexagon nut
4110	Stuffing box housing	6581-03	Hexagon nut
4120	Stuffing box gland	6581-04	Hexagon nut
4130	Gland packing	6700-01	Key
4131	Follower	6700-02	Key
4590-01	Gasket	6700-03	Key
4590-02	Gasket	7212-01	Half coupling rigid
4610-01	Round section joint ring	7212-02	Half coupling rigid
4610-02	Round section joint ring	7419-01	Coupling lock nut
4610-03	Round section joint ring	7419-02	Coupling lock nut
4610-04	Round section joint ring	7450	Coupling guard
6110	Baseplate	9665	Special flange
6515	Drain plug		

8.3 General arrangement drawing

The typical general arrangement drawing and any specific drawings required by the contract will be sent to the Purchaser separately unless the contract specifically calls for these to be included into the User Instructions. If required, copies of other drawings sent separately to the Purchaser should be obtained from the Purchaser and retained with these User Instructions.

9 CERTIFICATION

Certificates determined from the Contract requirements are provided with these instructions where applicable. Examples are certificates for CE marking, ATEX marking etc. If required, copies of other certificates sent separately to the Purchaser should be obtained from the Purchaser for retention with these User Instructions.

10 OTHER RELEVANT DOCUMENTATION AND MANUALS

10.1 Supplementary User Instructions

Supplementary instructions such as for a driver, instrumentation, controller, seals, sealant system etc are provided as separate documents in their original format. If further copies of these are required they should be obtained from the supplier for retention with these User Instructions.

10.2 Change notes

If any changes, agreed with Flowserve Pump Division, are made to the product after its supply, a record of the details should be maintained with these User Instructions.

10.3 Additional sources of information

Reference 1:

NPSH for Rotor dynamic Pumps: a reference guide, Euro pump Guide No. 1, Euro pump & World Pumps, Elsevier Science, United Kingdom, 1999.

Reference 2:

Pumping Manual, 9th edition, T.C. Dickenson, Elsevier Advanced Technology, United Kingdom, 1995.

Reference 3:

Pump Handbook, 2nd edition, Igor J. Karassik et al, McGraw-Hill Inc., New York, 1993.

Reference 4:

ANSI/HI 1.1-1.5, Centrifugal Pumps - Nomenclature, Definitions, Application and Operation.

Reference 5:

ANSI B31.3 - Process Piping

Nota:

Nota:

Nota:

Votre contact à l'usine Flowserve :

Flowserve Pompes
Route d'Angers - 72234 ARNAGE
BP 305, 72001 LE MANS Cedex, France

Téléphone (24 hours) : +33 2 43 40 58 47
Ventes & Admin : +33 2 43 40 57 57
Services & Rép. Fax : +33 2 43 40 58 17

Votre représentant local Flowserve :Amérique du Nord :

Flowserve
5310 Taneytown Pike, PO Box 91
Taneytown, MD 21787-0091, USA

Téléphone : +1 (410) 756 2602
Service Client FAX : +1 (410) 756 2615
Rechanges/Commande TEL : +1 (800) 526 3569

Amérique du Sud :

Flowserve do Brasil Ltda
Av. Don Helder Camara, 5451
20771-001 Rio de Janeiro

Tél : +55-21-2108-4000
Fax : +55-21-2108-4184

Pour trouver votre représentant local Flowserve,
utilisez le système de localisation du service après-
vente sur le site www.flowserve.com

**FLOWSERVE BUREAUX
COMMERCIAUX REGIONAUX :****USA et Canada**

Flowserve Corporation
5215 North O'Connor Blvd.,
Suite 2300
Irving, Texas 75039-5421 USA
Téléphone 1 972 443 6500
Fax 1 972 443 6800

**Europe, Moyen Orient &
Afrique**

Worthing S.P.A.
Flowserve Corporation
Via Rossini 90/92
20033 Desio (Milan) Italy
Téléphone 39 0362 6121
Fax 39 0362 303396

Amérique Latine et Caraïbes

Flowserve Corporation
6840 Wynnwood Lane
Houston, Texas 77008 USA
Téléphone 1 713 803 4434
Fax 1 713 803 4497

Asie Pacifique

Flowserve Pte. Ltd
10 Tuas Loop
Singapore 637345
Téléphone 65 6771 0600
Fax 65 6779 4607