



## ***Huizhou Quick Response Center***

Maintenance and Repair • On-Site Services  
Parts and Components • Pump Retrofits and Upgrades



***Experience In Motion***



## **Repair Service and Technical Support for Southern China**

*The Flowserve Huizhou Quick Response Center (QRC) focuses on providing customers with uncompromising service and support.*

*The Huizhou QRC is staffed by highly skilled engineers and technicians who are available around the clock, seven days a week to respond to customer queries, troubleshoot problems and provide reliable solutions.*

### **Strength of Experience, Commitment to Excellence**

The Huizhou QRC serves customers from industries requiring superior equipment performance and service life, such as:

- Oil and gas production
- Hydrocarbon processing
- Chemical processing
- Water resources
- Power generation
- Marine
- Mining and mineral processing
- Pulp and paper
- General industry
- Steel industry

### **Premier, Value-Added Service**

With unequalled pump knowledge, design expertise and manufacturing capabilities, the Huizhou QRC specializes in value-added repair services. QRC engineers and technicians service most types of equipment, including pumps, agitators and seals. The dynamic range of services offered by the Huizhou QRC include:

- Maintenance, repair and inspection service
- Pump upgrades, re-rates and retrofits
- Overhaul, outage and mechanical service
- Installation and commissioning service
- On-site repair and diagnostic services
- Contract maintenance
- Parts and components supply
- Field supervision
- Service maintenance contract





## Maintenance and Repair Services

### A Dynamic Range of Capabilities

The Huizhou QRC facility features 2300 m<sup>2</sup> (24 700 ft<sup>2</sup>) of shop and office space to support repair, engineering, sales and customer service functions. In-shop operations can handle a full range of pumps from small, single-stage overhung units to large multistage, between bearing pumps weighing in excess of 5 tons.

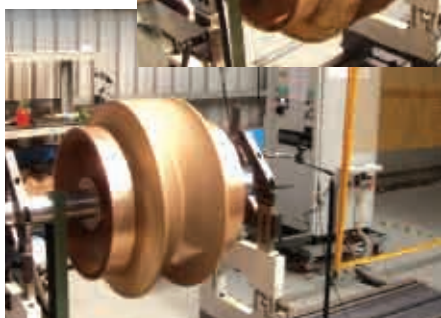

**Impellers and rotating assemblies weighing up to three tons are dynamically balanced on a computerized machine that provides a printed document verifying the results.**

The Huizhou QRC facility offers extensive machining services, including:

- Machining capabilities
  - 3 m x 152 mm (10 ft x 6 in) lathes
  - 3 m CNC lathe
  - Vertical mills
  - Vertical boring
  - EDM machine
  - Radial drills
  - Casing and mechanical seal lapping
- Finishing operations
  - Surface grinding
  - Sand blasting
  - Painting
- Assembly and fabrication
  - Certified welding to industry standards
  - Dynamic balancing (Schench 4M x 3T)
  - OPTALIGN® laser alignment
  - Heat treat ovens up to 1000°C (1832°F)
  - 50 tons hydraulic press
  - Hydraulic torque wrench
- Non-destructive examination (NDE)
- Quality control
  - 4 m run-out table
  - Flat table
  - Hardness tester
  - Surface roughness tester
  - 3D quadrant machine measuring
  - Seal testing

© OPTALIGN is a registered trademark of PRÜTECHNIK Dieter Busch AG.



## ***On-Site Services***

### ***Installation, Commissioning and Technical Services***

With limited staffing, customers often do not have the resources to supervise ongoing, equipment-related activities. As a result, field service experts from the Huizhou QRC are available to support customer start-up requirements:

- Equipment removal and handling
- Equipment installation
- Maintenance activities
- Start-up and commissioning
- Equipment foundation inspection
- Pipe and pump bolt-up, alignment and inspection
- Energy saving and life cycle advantage program



### ***Overhaul, Outage and Mechanical Services***

The Huizhou QRC has extensive experience and resources to provide integrated outage and mechanical services. Field service teams offer rapid mechanical assistance, including maintenance, upgrade and inspection services, during times of high demand.



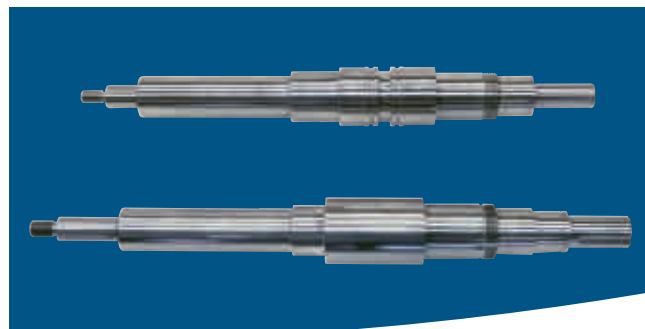

## Parts and Components

Quality parts complying to OEM specifications for the entire range of Flowserve product brands are readily available through the Huizhou QRC. As all parts conform to original design and materials specifications, customers are ensured reliable operation and lowest equipment ownership costs.

The Huizhou QRC can also re-engineer and produce non-Flowserve components for equipment that is obsolete or where the original equipment manufacturer cannot be located.

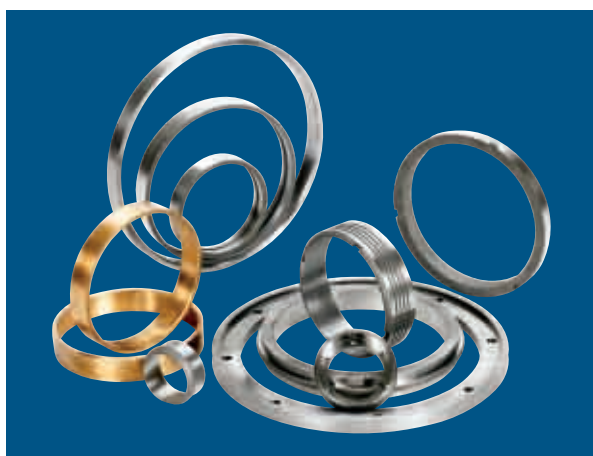

### *The Flowserve Advantage*

Flowserve manufactured parts offer significant benefits to customers. As an OEM, Flowserve understands the critical elements involved in designing and producing high quality parts. Whether cast or machined, Flowserve manufactured parts and components result in lower total operating costs and increased personnel safety.

- Flowserve casting quality is superior. Surface finishes, tolerances and material compositions are maintained within defined specifications.
- Flowserve parts incorporate the latest design changes which improve operating efficiency and extend equipment life
- Customers benefit from ongoing research to develop new materials, overlay techniques and mechanically improved components





## Upgrades, Re-rates and Retrofits

Unreliable and leaking pumps can be refurbished to “as-new” condition via myriad mechanical upgrade and retrofit options. Expert engineers from the Huizhou QRC facility have the experience to analyze and diagnose the root causes of mechanical pump failure and to recommend solutions that improve reliability, reduce emissions and increase plant uptime.

### Mechanical Upgrades and Retrofits

- ISO 13709/API 610 10th Edition upgrades, including the RVX and RHWX upgrades for horizontal and vertical overhung pumps, bring out-of-date process pumps to current API standards. This avoids costly new equipment investments.
- Other available mechanical upgrades, include:
  - Increased rotor stiffness (Superstraight™ shaft material)
  - Bearing housing and bearings
  - Mechanical seal upgrade to API 682
  - Seal chamber
  - Coupling
  - Wear ring

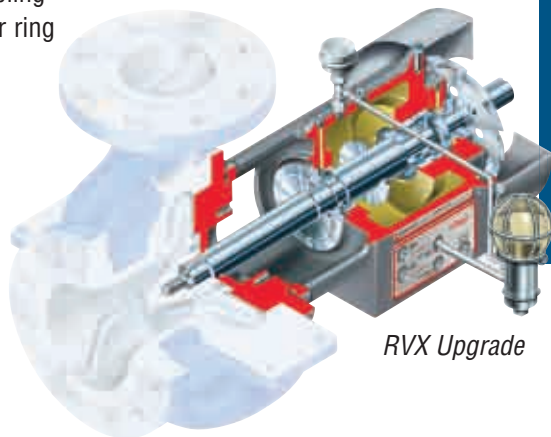

### Hydraulic Upgrades and Retrofits

Hydraulic re-rates can be provided to cover changes in flow or TDH, or increase efficiency for power savings.

- Optimization of lip and shroud clearances (A/B/C gap)
- Impeller modifications
- High-efficiency rotors
- Low flow modifications
- Re-bowling
- De-staging or upstaging
- Optimized hydraulics to reduce erosion/abrasion

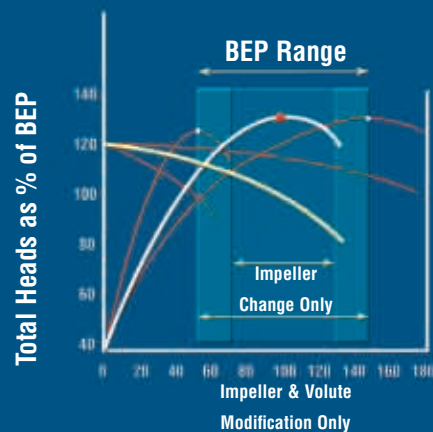

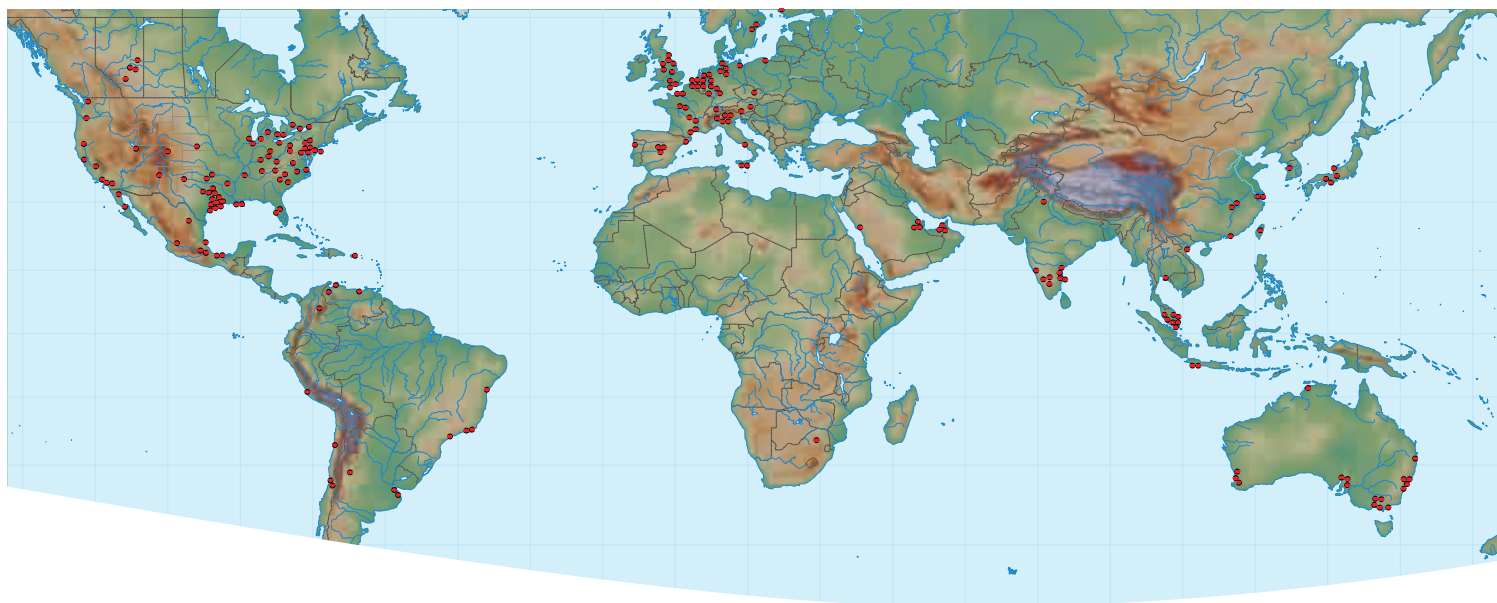

## Pump Supplier to the World

With an installed base of more than one million pumps, Flowserve Pumps has sales offices, service centers and manufacturing facilities all over the world. As a result of its extensive global footprint, Flowserve is ideally positioned to deliver best-in-class solutions to successfully address the world's most challenging projects.

### China Quick Response Centers



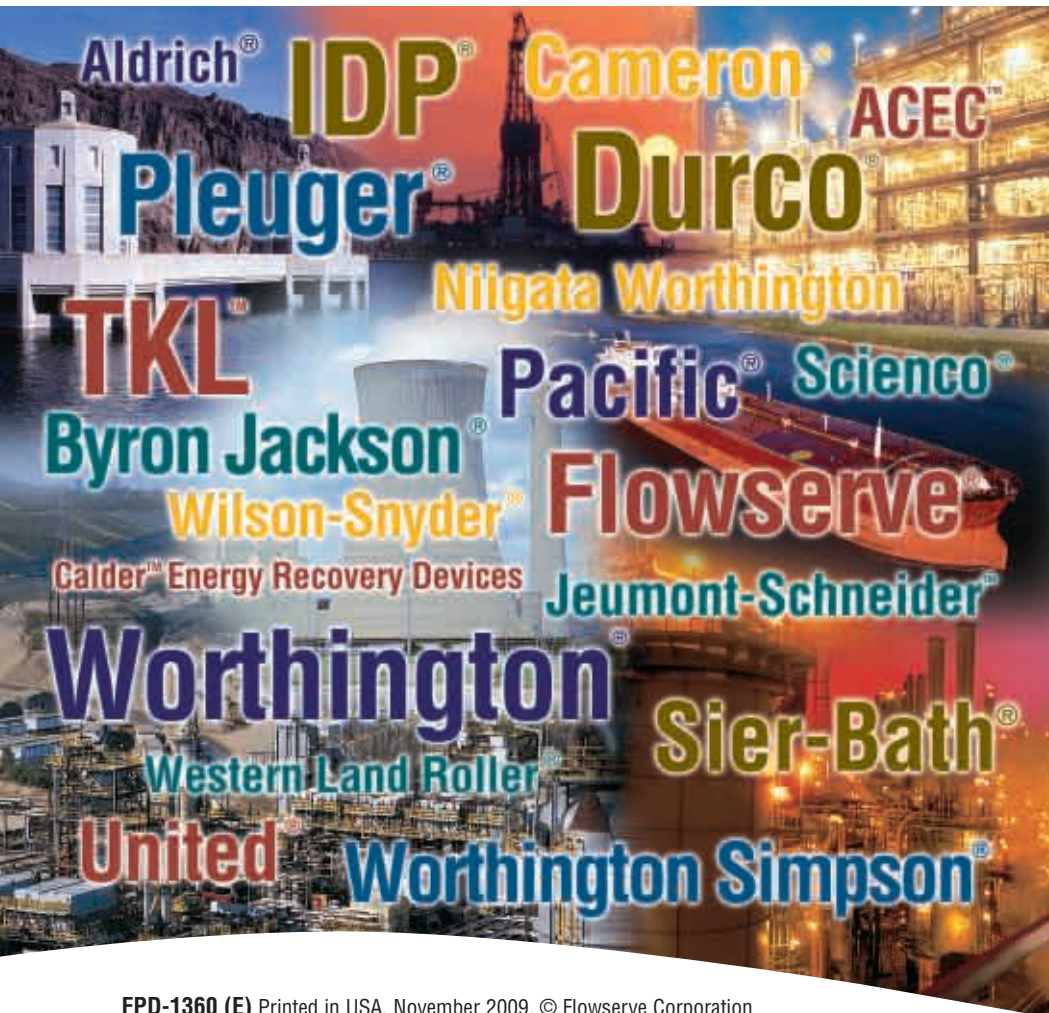

FPD-1360 (E) Printed in USA. November 2009. © Flowserve Corporation

**To find your local Flowserve representative:**

For more information about Flowserve Corporation,  
visit [www.flowserve.com](http://www.flowserve.com) or call USA 1 800 728 PUMP (7867)

**Huizhou**

Huizhou Quick Response Center  
Zhangpu industry park, Zhangpu  
Village, West Shihua Avenue, Daya  
Bay, Danshui Town, Huizhou City,  
P.R China  
Tel: 86-752-5280808  
Fax: 0755-29623137  
Zipcode: 516211

**Shanghai**

Unit 01\02\06\07, 9F,  
China Fortune Tower  
No. 1568, Century Avenue, Pudong  
Shanghai, 200122, China  
Tel: (86 21) 3865 4800  
Fax: (86 21) 5081 1781

**Suzhou**

NO.35 Baiyu Road, Industrial Park,  
Suzhou City 215021  
Jiangsu Province, China  
Tel: (86 512) 6288 8790  
Fax: (86 512) 6288 8737

**Beijing**

Room A1&A2,  
22nd Floor Hanwei Plaza  
No.7 Guanghua Road,  
Chaoyang District  
Beijing 100004, China  
Tel: (86 10) 5921 0600  
Fax: (86 10) 6561 3863

**Dalian**

Room 3203, Hongyuan Building,  
No.23 Renmin Road  
Zhongshan District,  
Dalian City, 116001  
Liaoning Province, China  
Tel: (86 411) 8256 2270  
Fax: (86 411) 8256 2273

**Shenzhen**

Unit 1101, Excellent Times Square,  
No.4068 Yitian Road, Futian  
District, Shenzhen City, 518048  
Guangdong Province, China

**Flowserve XD Changsha Pump  
Co., Ltd.**

15F business building  
Grand Sun City Hotel,  
No. 269 3rd block middle of Furong  
road, Changsha City, 410007  
Hunan province, China  
Tel: (86 731) 5588 438  
Fax: (86 731) 2244 728