



Technical Bulletin

Combined Cycle Unit Applications



Experience In Motion

Combined Cycle Unit Applications

Table of Contents	Page	Figures	Page
Introduction		Figure 1	Simplified Combined Cycle Power Plant..... 1
.....	1	Figure 2	Combined Cycle Unit Power Plant 2
Pump Recommendations		Figure 3	Integrated Gasification Combined Cycle Power Plant 3
Boiler Feedwater Services.....	4	Figure 4	Two-Turbine Combined Cycle Unit Pump Applications .. 4
Condensate Services	5	Figure 5	CO ₂ Recovery Unit 6
Circulating Water Services.....	5	Figure 6	A Post-Combustion CO ₂ Capture Unit..... 6
Ancillary Services	5	Figure 7	A Carbon Capture Unit in a Coal-Fired Power Plant..... 6
Guidelines for Mechanical Seals.....	5	Figure 8	Overview of Geologic Storage Options 7
CO₂ Capture and Sequestration			
CO ₂ Capture.....	6		
CO ₂ Transportation	7		
Sequestering.....	7		

Introduction

Driven largely by economic growth in developing countries, global energy demand is expected to surge more than one-third by 2030. Fossil fuels still continue to make up most of the mix with natural gas and coal accounting for a little more than 44% of electricity generation. (Source: International Energy Administration.)

The “Economist” magazine reports the world’s population currently consumes about 15 terawatts of energy annually. By 2030, global power consumption will likely rise to 30 terawatts. To put this in perspective, a terawatt is 1000 gigawatts and a gigawatt is the capacity of the very largest coal-fired power stations. A typical combined cycle power station generates 450 to 500 megawatts.

Advantages of Combined Cycle Power Plants

Combined cycle power plants have many advantages compared with other fossil fuel plants. (See Figure 1.) Chief among these is the fact that natural gas is a relatively clean burning fuel, emitting far less SO_x, NO_x, mercury and CO₂ than coal. This is a significant benefit as movement toward carbon taxes grows globally. Other advantages include:

- Lower initial investment cost (about one half that of coal-fired plant: U.S. \$1.0 billion per 550 mW vs. U.S. \$ 2.0 billion)
- Shorter construction cycle
- Smaller land parcels needed
- Higher efficiency (58 to 60% vs. 38 to 42%)
- Lower operating and maintenance costs
- Faster return on investment
- Easier permitting
- Versatility

It should be noted that operating costs of combined cycle power plants are highly price sensitive to and dependent upon an abundant, reliable supply of natural gas. While coal is less expensive than natural gas, the cost associated with handling, processing and cleaning emissions are significantly higher than those related to natural gas. Furthermore, global environmental treaties and carbon-related taxes will almost certainly discourage the use of coal in favor of natural gas.

Before reviewing combined cycle processes in detail, it will be helpful to define several associated terms to avoid confusion.

First of all, do not confuse combined cycle with cogeneration. Combined cycle is an electric generating technology in which additional electricity is produced from otherwise lost waste heat exiting from gas turbines. The exiting heat is routed to a conventional boiler or to a heat recovery steam generator for utilization by a steam turbine in the production of electricity. The process significantly increases the efficiency of the electricity generating unit from 38 to 42% to 58 to 60%. “Cogen,” on the other hand, is the simultaneous production of electricity and steam from the same energy source. For example, burning natural gas produces electricity and heat. The heat is captured and converted to steam for space heating or industrial process use.

Figure 1 – Simplified Combined Cycle Power Plant

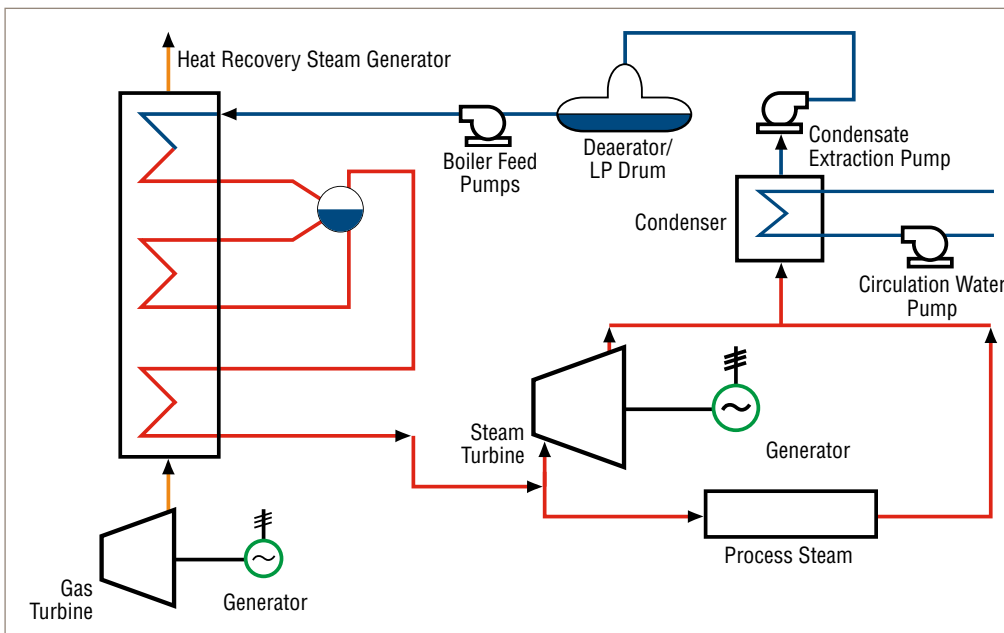
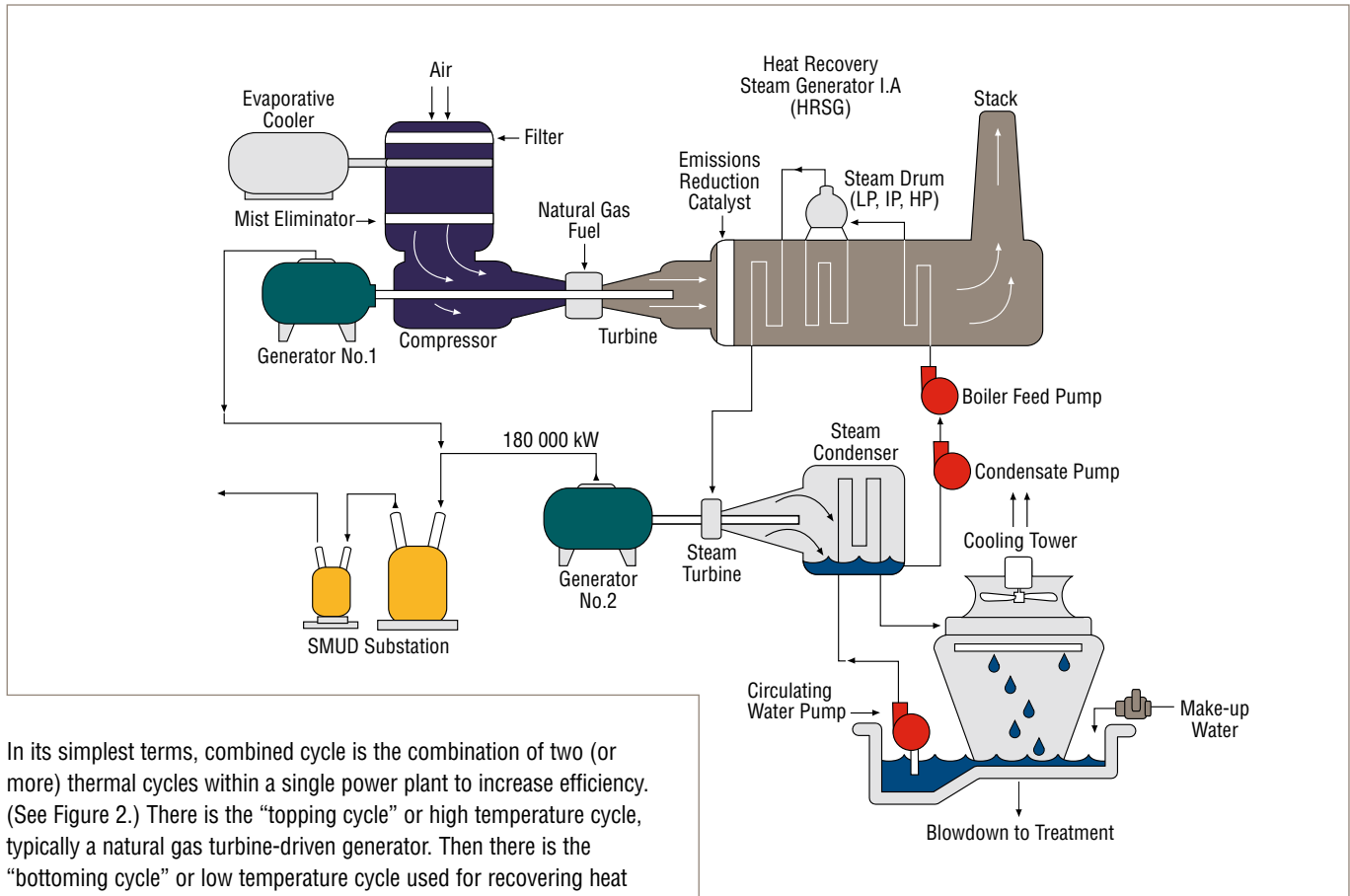

Figure 2 – Combined Cycle Unit Power Plant



In its simplest terms, combined cycle is the combination of two (or more) thermal cycles within a single power plant to increase efficiency. (See Figure 2.) There is the “topping cycle” or high temperature cycle, typically a natural gas turbine-driven generator. Then there is the “bottoming cycle” or low temperature cycle used for recovering heat from the topping cycle to produce additional electricity through a steam turbine-driven generator.

The combustion gas turbine operates on the Brayton cycle. It uses a compressor to compress the inlet air upstream of a combustion chamber. Then the fuel is introduced and ignited to produce a high temperature, high pressure gas that enters and expands through the turbine section. The turbine section powers both the generator and compressor. Combustion turbines are able to burn a wide range of fuels including natural gas and synthesis gas produced by coal gasification.

The conventional (fossil) steam plant operates on the Rankine cycle. The steam is created by a boiler, where pure water passes through a series of tubes to capture heat from the firebox and then boil under high pressure to become superheated steam. The superheated steam leaving the boiler then enters the steam turbine throttle, where it powers the turbine and connected generator to make electricity. After the steam expands through the turbine, it exits the back of the turbine where it is cooled and condensed back to water in the surface condenser. The condensate is then returned to the boiler through high pressure feed pumps for reuse. Heat from the condenser is normally rejected from the condenser to a cooling tower or a body of water such as a river.

In a combined cycle power plant, a waste heat boiler is installed onto the gas turbine exhaust stream. Known as heat recovery steam generators (HRSG), they are used to produce steam from hot gas turbine exhaust to drive a steam turbine which in turn drives an electric generator.

The result: a combined cycle power plant increases thermal efficiency by as much as 60%.

An Emerging Technology: Integrated Gasification Combined Cycle

Coal is abundant and relatively cheap. The United States alone has more coal than the rest of the world has oil. There is still enough coal underground in America to satisfy its energy needs for the next 200 to 300 years. But coal has become an environmental villain as the world’s concerns about pollution and climate changes have increased dramatically. In the future, all coal and coal gasification combined cycle plants will require some form of CO₂ capture and sequestration. For more details, see page 6.

The continued dominance of coal as the fuel of choice for power generating plants may well depend upon clean coal technology, a new generation of energy processes that sharply reduce air emissions and other pollutants compared to older coal-burning systems. To date, the application of clean coal technology has largely been restricted to pilot plant scale. However, in August 2008 Montana's Crow Nation and Australian-American Energy Co. announced plans to construct a U.S. \$7 billion coal-to-liquid (CTL) fuels plant in southeastern Montana. It is expected to open in 2016.

This CTL project presents an ideal opportunity for coal, utility and petroleum companies to collaborate. Utility companies want to turn coal into electricity, while coal companies seek to expand their market from solely power generation to liquid hydrocarbon conversion and petroleum companies can use the carbon dioxide (CO₂) produced for enhanced oil recovery (EOR).

Integral to the CTL fuels process is integrated gasification combined cycle (IGCC), a technology that turns coal into gas – synthesis gas (syngas). (See Figure 3.) In a typical IGCC plant, coal is first gasified to synthesis gas – hydrogen and carbon monoxide (CO). The synthesis gas is scrubbed to remove acid gases and mercury. The syngas is then burned in the combustion turbine, and hot exhaust is captured in a waste heat boiler or HRSG and used to raise steam to drive a second turbine. As in natural gas combined cycle, both turbines produce electricity while significantly increasing thermal efficiency: 58 to 60% for IGCC operation versus 38 to 42% for a direct-fired coal unit.

While the IGCC gas plant is far more complex than that of the natural gas combined cycle unit, both the power generating sections and pumping equipment are virtually identical.

Figure 3 – Integrated Gasification Combined Cycle Power Plant

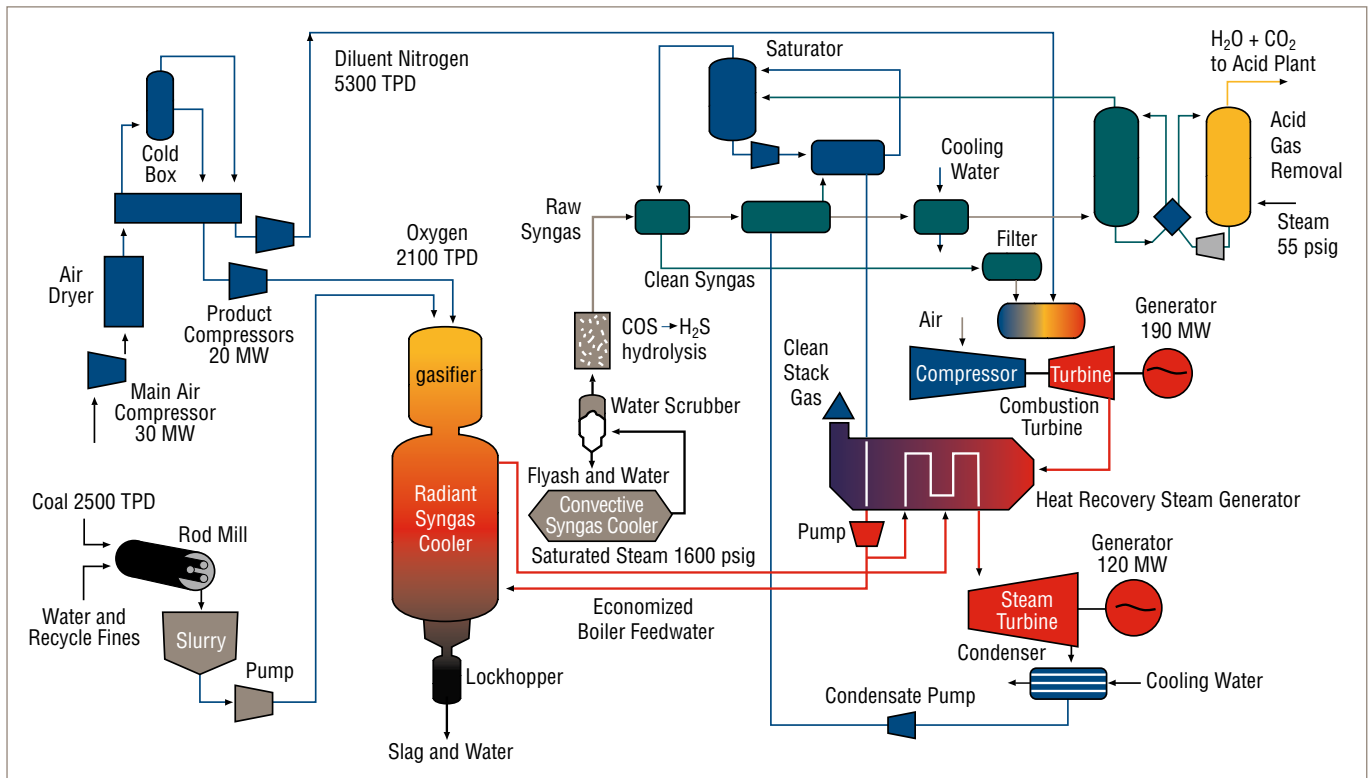

Pump Recommendations

Flowserve has achieved a reputation for supplying high quality, dependable pumping equipment to the electric power generation industry and has gained a wealth of experience through handling many of the critical services found in central power generating units. Most of the critical applications in combined cycle units involve water handling – namely, boiler feedwater services, condensate services and water circulating services.

Boiler Feedwater Services

The boiler feedwater pumps must handle high pressures and fairly high flow rates and for these services between bearing multistage pumps are commonly used. For very high pressure, double case pumps are sometimes required; Flowserve models DMX and WXH are commonly used. These between bearings, multistage pumps offer the following features and benefits:

Feature	Benefit
Choice of axially or radially split case	Ease of maintenance
Choice of volute or diffuser case construction	Fluid dynamics best suited for application
Double-suction first-stage impeller (option)	Minimizes NPSHR
Flanged balance drum or hydraulically balanced rotating unit	Balances hydraulic thrust and reduces vibration
Finned bearing housing	Maximizes heat dissipation

Regardless of the size of a combined cycle unit, the water handling pumps are critical elements in the performance of the unit. To give a sense of the types of pumps typically used and the configuration of these pumps, presented below is the water handling pumps for 500 MW combined cycle unit. This is a two-turbine unit and Figure 4 is a schematic of this unit and showing the placement of the pumps.

- HRSG Feedwater Pumps
 - Total dynamic head (TDH) @ rated capacity – 5800 ft (1770 m)
 - Capacity @ rated TDH – 950 gpm (215 m³/h)
 - Temperature – 300°F (150°C)
 - Pump model – WXH (4x12LC, 9 stage)
 - Materials of construction – Suction and discharge casing are ASTM A216 Grade WCB; impellers are ASTM A743, Grade CA-6NM
- Mechanical seal – Flowserve Type QB (Material Code – 5N4A; API Code – BSTFM)
- Auxiliary Steam Boiler Feedwater Pumps
 - (These pumps are not shown in Figure 4. These are used as start-up pumps or as fill pumps for the system and their location will depend on the individual system design.)
 - Total dynamic head (TDH) @ rated capacity – 760 ft (230 m)
 - Capacity @ rated TDH – 550 gpm (125 m³/h)
 - Temperature – 105°C (220°F)
 - Pump model – HPX (3x6x15M)
 - Material of construction – Case: Carbon steel; impeller: ASTM A743, Grade CA-6NM
 - Mechanical seal – Flowserve Type QB (Material Code – 5N4A; API Code – BSTFM)

Figure 4 – Two-Turbine Combined Cycle Unit Pump Applications

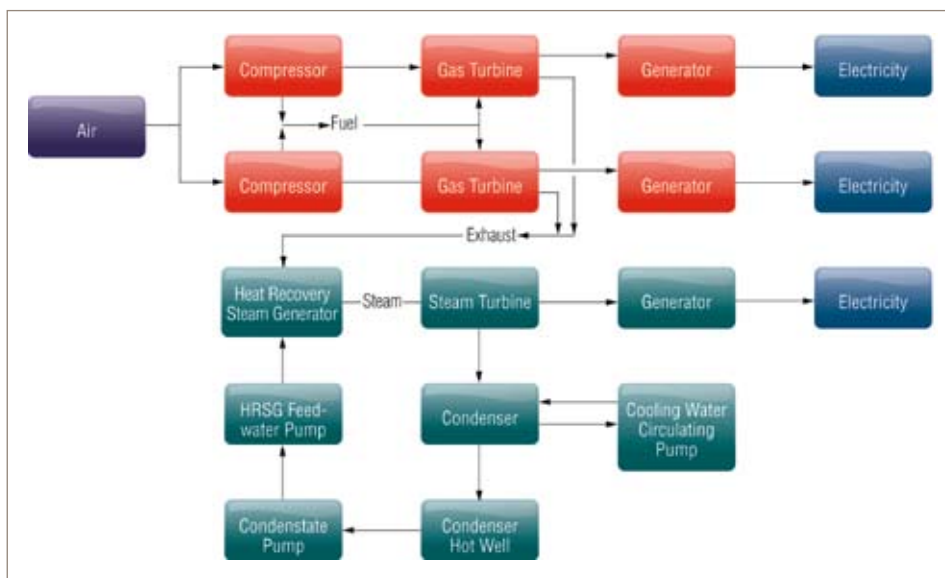

Condensate Services

Condensate services typically have very low values for NPSH available and vertically suspended double case pumps are used. For condensate water services, Flowserve model APKD and VPC pumps are commonly used. These vertically suspended pumps offer the following features and benefits for these difficult services:

Feature	Benefit
Standard large eye first-stage impeller	Very low NPSH required
Integral wear rings	Lower initial cost
Registered motor fit	Better alignment, reduced vibration
Four piece rigid adjustable coupling	Superior alignment, eases seal replacement

- Condensate Pumps
 - Total dynamic head (TDH) @ rated capacity – 575 ft (175 m)
 - Capacity @ rated TDH – 1475 gpm (335 m³/h)
 - Temperature – 100°F (38°C)
 - Pump model – APKD
 - Material of construction – Case and impeller (Cast iron)
 - Mechanical seal – Flowserve Type QB (Material Code – 5N4A, API Code – BSTFM)

Circulating Water Services

Circulating water services characteristically have very high flow rates at low pressures and vertically suspended mixed flow and axial flow pumps are used. Typical models include the PMR, APH, APMA and HXH. Features and benefits of these pumps include:

Feature	Benefit
Open and semi-open impellers	Optimum hydraulic coverage
Integral bearing retainer	Positive alignment, reduced maintenance
Engineered to customer specifications	Maximize efficiency
Split-ring, keyed impeller	Reliable, safe operation

- Circulating Water Pumps
 - Total dynamic head (TDH) @ rated capacity – 80 ft (24 m)
 - Capacity @ rated TDH – 55 300 gpm (12 560 m³/h)
 - Temperature – 80°F (27°C)
 - Pump model – 48 HXH (1 stage)
 - Material of construction – Case (Cast iron), impeller (316L SS)
- Air-to-air Heat Exchangers
 - In arid regions the use of fresh water for cooling purposes is being reduced. About one in six plants now uses these types of cooling systems, which require no pumps. They also require significantly more land to construct which is an additional cost.

Ancillary Services

Depending on the combined cycle unit design, there can be applications for other types of Flowserve pumps. These include:

- Service water
- Chlorine booster
- Evaporator coil feed
- Filter backwash
- Gland water circulation
- Auxiliary cooling water
- Glycol solution recirculation
- Evaporator feed
- Service water jockey
- Glycol heater drain
- Turbine oil transfer
- Chemical feed

An integrated gasification combined cycle unit (IGCC) will include a coal handling system and there will probably be a need for the following pumps:

- Dust suppression spray
- Dump building sump
- Coal pile runoff pond
- Treatment pond discharge
- Floor drain sump

Guidelines for Mechanical Seals

Water, particularly hot water, is difficult to seal. As the temperature increases, the viscosity, and therefore the lubricity, of water drops dramatically. For this reason, proper seal design and materials of construction are critical to providing long and dependable life. Wavy-face seal technology may provide the best solution in these critical services. To ensure proper seal selection for the critical water handling pumps in a combined cycle unit, the advice of a Flowserve FSD sealing specialist should be sought.

CO₂ Capture and Sequestration

Interest in CO₂ Capture and Sequestering (CCS) has increased lately as the world begins to struggle with the problems of greenhouse gases and their potential impact on global warming. The Intergovernmental Panel on Carbon Capture (IPCC) estimates that the global emissions of CO₂ from fossil fuels in 2000 were 23.5 billion tons. By 2020 this may grow to 44 billion. In order to stabilize CO₂ concentration in the atmosphere and reduce the increasing impact CO₂ emissions have on raising temperatures, hundreds of billions of tons of CO₂ will need to be captured and permanently stored [1].

CO₂ Capture

The key to CCS is the capture of CO₂ from point sources. Power plants are the current focus due to their high emission rates of the gas: about 11 billion tons per year at a rate of one ton per megawatt-hour of generation capacity. Other point sources include cement mills, with an emission of about 900 million tons per year, and refineries, which emit approximately 700 million tons per year [1].

Three primary capture technologies are being investigated:

- Post-combustion where the CO₂ is removed from the flue gas.
- Pre-combustion where the fuel is modified to remove the CO₂ before combustion. Coal to gas technology uses this type of capture.
- Oxyfuel combustion where pure oxygen is used instead of air in the combustion process to produce a flue gas that is 80% CO₂. The flue gas can be compressed and stored without additional processing.

Capture of CO₂ from flue gas will require a significant investment for power plants and other emission sources. Like the SO_x recovery projects of the late 1990s, new process units will need to be installed to remove the CO₂ from the flue gas. Figure 5 shows a schematic of a CO₂ typical recovery unit. This type of unit can be used in both post and pre-combustion processes.

Figure 5 – CO₂ Recovery Unit
Source: [2]

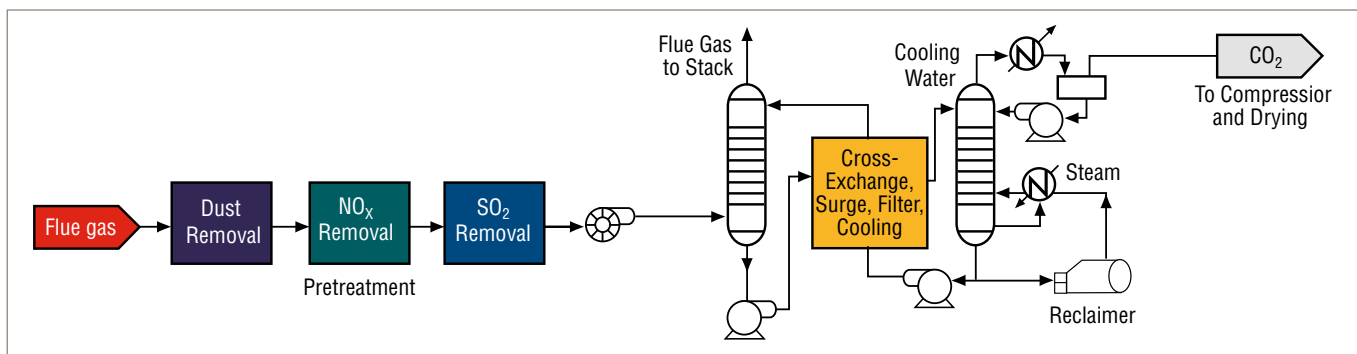

Figure 6 – A Post-Combustion CO₂ Capture Unit
Source: [1]

Figure 6 shows a post-combustion capture unit on a chemical plant in Malaysia and Figure 7 shows the carbon capture unit of a coal gasification power plant.

In addition to the process unit itself, site utilities such as cooling water and power supply will also have to be upgraded. With the emphasis of reducing potable water, power plant designers are focusing on air-to-air heat exchangers which will reduce water systems but increase land needs.

CO₂ capture is still a developing technology and the key issue is the cost. There are very few commercial units operating and most projects are government-sponsored pilot programs. However, once global laws regulating CO₂ emissions are in place, probably in the next two to five years, CO₂ capture will become a large market.



Figure 7 – A Carbon Capture Unit in a Coal-Fired Power Plant (circled area)
Source: [1]

Figure 8 – Overview of Geologic Storage Options
 Source: [1]

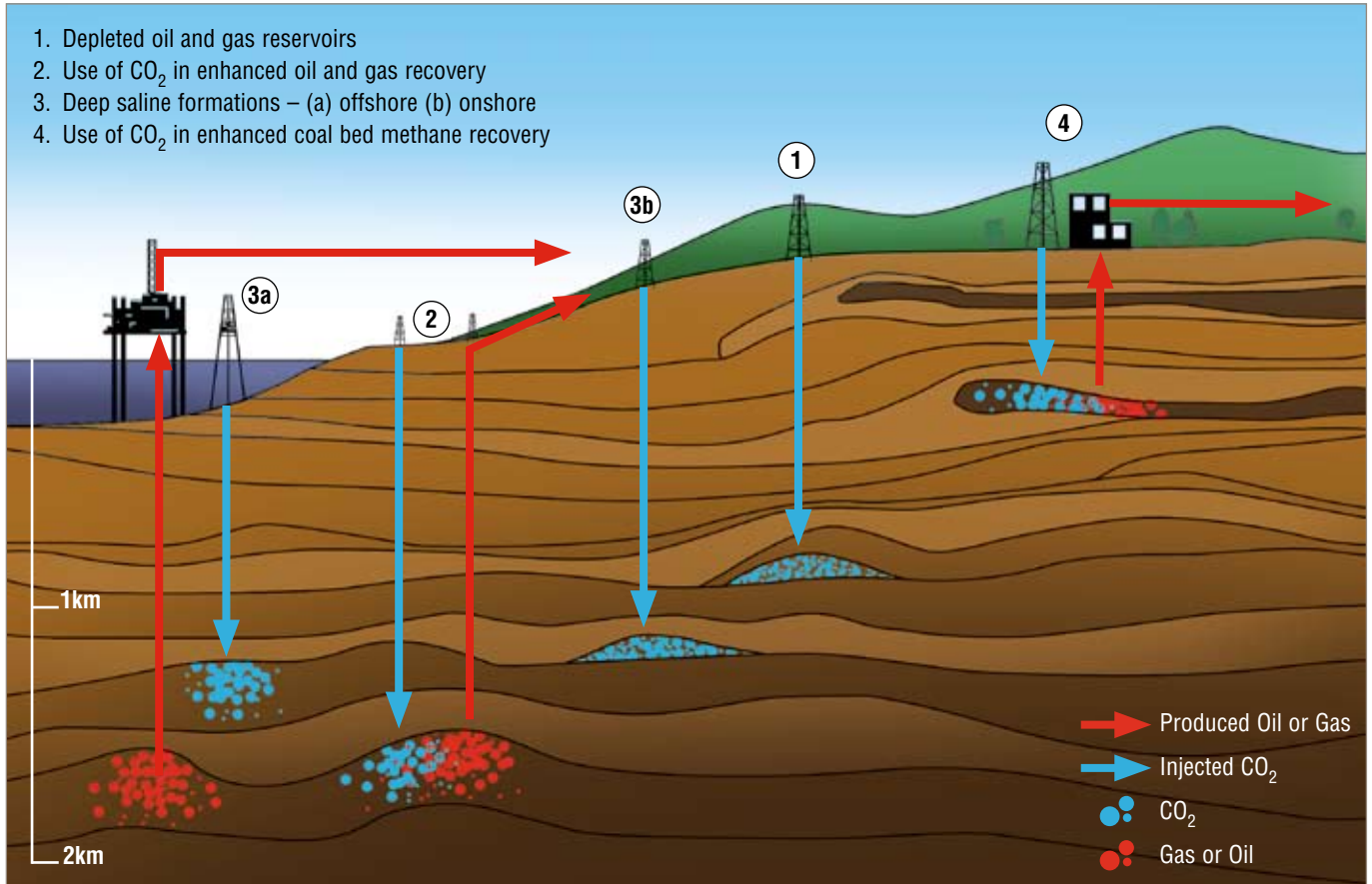

CO₂ Transportation

Once the CO₂ is captured at the emission source it must be transported to the storage site. The most economical method for transportation is through pipelines, although liquefying the gas and transporting by ship and rail are being studied. In pipeline operations the gas is compressed to high pressures, greater than 1500 psi (100 bar) where it behaves more like a liquid than a gas (i.e., the dense phase). Once in the dense phase, pumps can then be used to move it through the pipeline. Pipeline transportation is proven technology and currently there are over 1500 miles (2500 km) of CO₂ pipelines in the United States.

Sequestering

The goal of sequestering is to permanently store CO₂ and prevent its escape to the atmosphere. Several sequestering options have been proposed, including injecting it into deep oceans, or converting it to carbonate minerals, but the leading solution is geologic storage. Figure 8 from IPCC's 2005 report shows the various geologic storage options.

Geologic storage is favored since the technology is already present. Additionally, the geologic storage options of injecting the CO₂ into active oil and gas reservoirs in order to increase production actually produce a market for waste gas. While the technology to inject CO₂ into the ground is proven, government agencies around the world are conducting research to determine whether the geologic storage is a permanent solution for CO₂ sequestering.

References

1. Metz, B., O. Davidson, et al. eds. 2005. Carbon Dioxide Capture and Storage. New York City. Cambridge University Press.
2. Friedman, B., R. Wissbaum, and S. Anderson, Various Recovery Process Supply CO₂ for EOR Projects, Oil & Gas Journal (23 August, 2004).

Notes

Notes



Bulletin FPD-1308 (E/A4) Printed in USA. April 2009. © Flowserve Corporation

To find your local Flowserve representative:

For more information about Flowserve Corporation,
visit www.flowserve.com or call USA 1 800 728 PUMP (7867)

USA and Canada

Flowserve Corporation
5215 North O'Connor Blvd.
Suite 2300
Irving, Texas 75039-5421 USA
Telephone: 1 937 890 5839

Europe, Middle East, Africa

Flowserve Corporation
Gebouw Hagepoint
Westbroek 39-51
4822 ZX Breda
Netherlands
Telephone: 31 76 502 8920

Latin America

Flowserve Corporation
Boulevard del Cafetal
Edificio Ninina, Local 7
El Cafetal - Caracas
Venezuela 1061
Telephone: 58 212 985 3092
Telefax: 58 212 985 1007

Asia Pacific

Flowserve Pte. Ltd.
200 Pandan Loop #06-03/04
Pantech 21
Singapore 128388
Telephone: 65 6771 0600
Telefax: 65 6779 4607