



*Flowserve – Anchor Darling
Double Disc Gate Valves*

Double Disc Gate Valves

Problem

Failure to pass a Local Leak Rate Test (LLRT) is most often cited as the reason nuclear plant valves require maintenance during annual refueling outages. It is estimated that 75 percent of the valve rework performed consists of lapping seats and discs in an attempt to get the valve to pass the low-pressure air test required to demonstrate containment integrity.

Solution

A solution to valve LLRT problems has been available for many years; however, when valve specifications were developed for the earlier nuclear plants, they did not address the need for LLRT. The parallel-seat, double-disc gate valve, with a wedging mechanism capable of providing mechanical loading to achieve required seating stress, has been manufactured for over seventy years and will perform with tight seating for LLRT.

Abstract

In a plant with over 10,000 valves, it may seem somewhat surprising that such a high percentage of maintenance man-hours are directed to the approximately 100 valves that perform a containment isolation function. However, after reviewing the types of valves most often installed in these applications and considering the severity of the tests required, the number is not at all surprising.

That the problem exists is somewhat understandable when you consider that most

Disc and Wedge Assembly

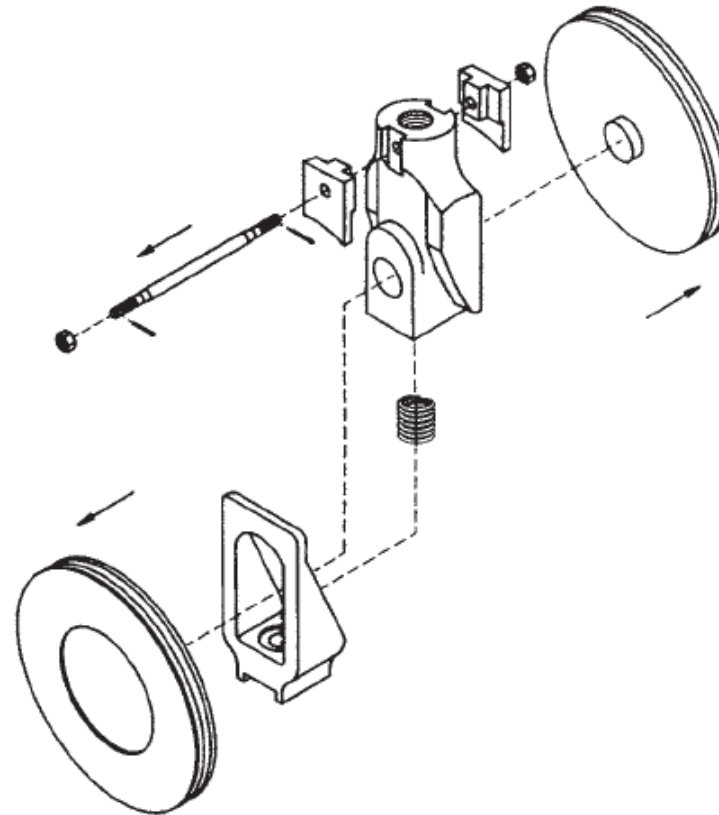

of the plants were constructed prior to 10CFR50 Appendix J being written. The plant designers at the time did not require valve sealing containment penetrations to meet more severe leakage requirements.

The majority of the valves in these applications, while having paper pedigrees

befitting nuclear service, were commercial-quality gate valves of a wedge-type design or globe valves with quick-opening plugs. Both types of valves, when properly manufactured, are capable of sealing most liquids as long as a certain amount of leakage is acceptable.

Double Disc Gate Valves

However, when these valves are called upon to pass a low-pressure air test with leak rates as low as 1/10 SCF/hr, they almost invariably fail.

All valves, in order to provide a tight seal, must have the disc and the seat surfaces in complete contact around 100 percent of the sealing area. Why is it that valves may easily pass a 200 psi hydro test and fail a low-pressure air test? The answer, although somewhat different for a wedge gate than a globe valve, is related to both the fluid involved and the pressure at which the test is conducted.

Gases (air included) are always a more difficult fluid to seal against than liquids. Their smaller molecular structure simply allows them to pass through smaller discontinuities between the disc and seat sealing surfaces. As a result, they require the surface finishes of the sealing areas to be more highly polished than for liquid sealing. Achieving a highly polished surface is not difficult during manufacture, but maintaining it during plant operation is difficult. This is particularly true for valve types where the disc and seat tend to impact on one another during closing.

Pressure is involved from the standpoint that small discontinuities in the sealing surfaces can be corrected with the application of sufficient force. Two sealing surfaces, while not perfectly matched, can be made to seal if

they are pressed together with enough force. The application of the stress causes one or both of the surfaces to deform sufficiently to close gaps and prevent the passage of fluid.

From the above, it is apparent that a 10 psi air test is a far more difficult test to pass than a 200 psi hydro. The fluid will go through smaller gaps, and there isn't as much pressure to close the gaps.

Wedge gate valves are probably the poorest valve choice for low-pressure sealing. Of all the isolation valve designs, they are the least forgiving of a mismatch between the angle of the disc and seat plane.

With sufficiently precise machining, the angles of the disc and the seat can be held close enough so that when the valve is put on a test stand, it will be bubbletight. If the seat width is designed correctly, it can even pass a low-pressure air test.

However, when installed in a piping system and subjected to repeated thermal transients, the angles of seats are almost guaranteed to change. With the seat angle no longer matching the disc angle, leakage is inevitable. If the valve is of the flexible wedge design and sufficient force is applied, the wedge can be made to deform to match the new seat angle. A 1000 psi hydro test will generally provide enough force to achieve this deformation. Unfortunately, the force provided by a 49 psi Local Leak Rate Test will rarely be sufficient to

deform the wedge enough, and the valve fails the test.

In the early days of nuclear power plants, engineers discovered that bypassing the motor operator torque switches added enough force to drive the wedge into the seat to deform it and get it to seal. They also discovered this practice burned out motors and cracked the stellite on the sealing surfaces.

Most well-engineered globe valves are designed with enough plug-stem flexibility to permit the plug to fit into the seat even if the angle of the seat plane has changed due to piping and thermal stresses. As a result, they will initially exhibit fewer problems in passing a LLRT than will a wedge gate. However, maintenance records indicate they too will eventually become candidates for repair due to LLRT failure.

The globe valve's weakness in containment isolation service is related mostly to the contact area between the seat and the plug. Because the seat width must be narrow in order to achieve a tight seal, it is easily damaged. In that all containment isolation valves are required to close quickly to minimize containment outleakage during a LOCA, the motor or air actuator speeds create significant inertial forces in the plug-stem assembly during closing. Unfortunately, most of this dynamic energy is converted to an

Double Disc Gate Valves

Internal Arrangement Double-Disc Gate Valve

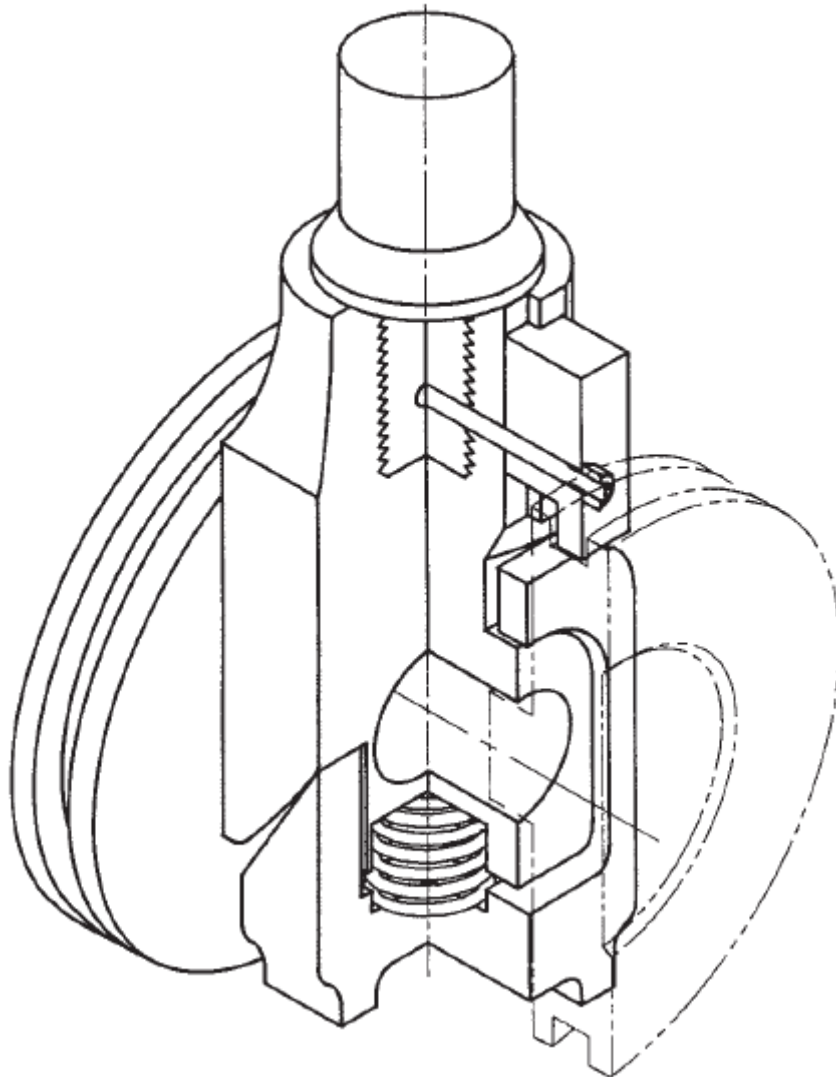

impact force that must be absorbed by the narrow seat contact area when the plug motion is halted. The result is that the seat is peened every time the valve is closed. It doesn't take very many closures before the seat is so badly deformed that leakage results.

The classic example of this problem is the Y-Globe valve used for Main Steam Isolation Valves in many plants. Their failure to pass LLRTs results in the single largest valve-related operation and maintenance dollar expenditure in light water reactors.

The ability of double-disc gate valves to provide reliable sealing for LLRT and also function under severe loading conditions is related to the unique design of its sealing mechanism. This design consists of two symmetrical free-floating discs with a wedging mechanism located between them. The independent floating discs assure that the disc and seat sealing surfaces will remain in contact regardless of how much the seat angles may change due to piping mechanical and thermal loads. In addition, the wedging mechanism between the discs can provide sufficient mechanical loads to ensure that the necessary seating stress is available to provide tight seating at LLRT pressures.



Flowserve Corporation has established industry leadership in the design and manufacture of its products. When properly selected, this Flowserve product is designed to perform its intended function safely during its useful life. However, the purchaser or user of Flowserve products should be aware that Flowserve products might be used in numerous applications under a wide variety of industrial service conditions. Although Flowserve can (and often does) provide general guidelines, it cannot provide specific data and warnings for all possible applications. The purchaser/user must therefore assume the ultimate responsibility for the proper sizing, selection, installation, operation and maintenance of Flowserve products. The purchaser/user should read and understand the Installation Operation Maintenance (IOM) instructions included with the product and train its employees and contractors in the safe use of Flowserve products in connection with the specific application.

While the information and specifications contained in this literature are believed to be accurate, they are supplied for informative purposes only and should not be considered certified or as a guarantee of satisfactory results by reliance thereon. Nothing contained herein is to be construed as a warranty or guarantee, express or implied, regarding any matter with respect to this product. Because Flowserve is continually improving and upgrading its product design, the specifications, dimensions and information contained herein are subject to change without notice. Should any question arise concerning these provisions, the purchaser/user should contact Flowserve Corporation at any one of its world-wide operations or offices.

For more information about Flowserve Corporation, contact www.Flowserve.com or call USA 1-800-225-6989

Flowserve Corporation

Flow Control Division

Edward & Anchor/Darling Valves
1900 South Saunders St
Raleigh, NC 27603 USA

Toll – Free Telephone Service

(U.S. and Canada)

Day: 1-800-225-6989

After Hours Customer Service

1-800-543-3927

U.S. Sales Office

Phone: 919-832-0525

Fax: 919-831-3369

Website:

www.Flowserve.com