



USER INSTRUCTIONS

Installation
Operation
Maintenance

Valtek GS

General Service Control Valve
Type V701

FCD VLEEIM0300-05 11/22

This document is the 'Original Instructions'



General Service Control Valve - Valtek GS

The Valtek GS product line is low cost, compact and light-weight. Yet, it is rugged and can be used safely and confidently in a wide range of general service applications plant-wide. Its modular design provides trim and material options to suit most service situations. Simplicity of design reduces maintenance and parts inventory costs. It is ideally suited for flow and pressure control of liquid and gas media in oil and gas, power, chemical and petrochemical processing and related industries. The Valtek GS control valve package provides flow rates, control accuracy and reliability at levels comparable to special engineered service control valves, but at a significantly lower cost. The Valtek GS is manufactured to ISO 9001 standards.

The following instructions are designed to assist in unpacking, installing and performing maintenance as required on Flowserve Valtek GS control valves. This instruction manual does not include specific product design data. Such data can be found on the valve's serial plate or specification documents; additionally, dimensional information can be found in the Valtek GS technical bulletin. Procure needed documents as necessary before you begin any work on the valve.

User Instructions cannot deal with all possible situations and installation options. It is required that only trained and qualified technicians are authorized to adjust, repair or work on control valves, actuators, positioners and other accessories. Review this bulletin prior to installing, operating or performing any maintenance on the valve. Additional Installation, Operation, and Maintenance Instructions (IOMs) cover other features (such as special trim, actuators, handwheels, packing and positioners).

To avoid possible injury to personnel or damage to valve parts, WARNING and NOTICE indicators must be strictly followed. Modifying this product, substituting non-factory parts or using maintenance procedures other than outlined could drastically affect performance and be hazardous to personnel and equipment and may void existing warranties. This manual should be used in conjunction with applicable local and national laws. Failure to comply with User Instructions will render the manufacturer's guarantee and liability null and void. Unless otherwise agreed, the manufacturer's general terms and conditions of sale shall apply.

**Read the user instructions carefully before use.
Keep for future reference.**

Contents

1	Scope of Manual	3	10	Valve Quick-Check	7 - 8
2	Intended Use	3	11	Valve Maintenance	8 - 10
3	Product Identification	3	12	Troubleshooting	10 - 11
4	Valtek GS Modification	3 - 4	13	Disassembly and Reassembly	12 - 19
5	Safety	4	14	Torque Requirements	20
6	Packaging and Transport	4	15	Lubricants	20
7	Storage	4	16	Special Tools	21
8	Unpacking	4 - 5	17	Parts List	22
9	Installation	5 - 7	18	Disposal	23

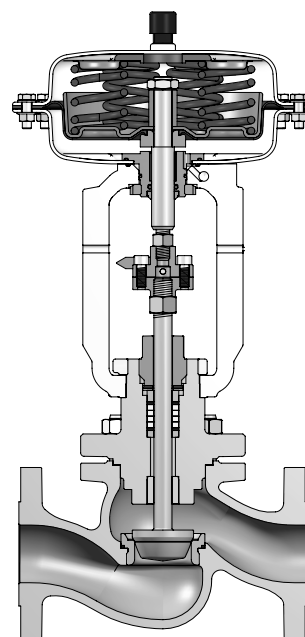

Figure 1: Valtek GS with Standard / Extended Bonnet

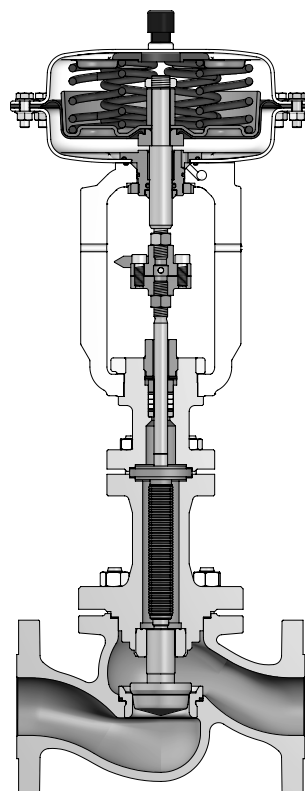

Figure 2: Valtek GS with Bellows Seal Bonnet

1 Scope of Manual

The following user information covers the Valtek GS general service control valve:

- Metric DIN Units - PN 16 / 40, DN 15 - 150
- English ASME Units - Class 150 / 300, NPS ½ - 6
- Assembled with a pneumatic or electric linear actuator
- Comes with or without ancillary equipment

2 Intended Use

WARNING Control valves are pressure vessels designed and rated for specific application conditions. Before installation, check the serial number and / or the tag number to ensure that the valve and actuator being installed are correct for the intended application. Do not use the valve outside of its rated design limits. Exceeding the design limits may cause hazardous conditions including leakage of the process media or rupture of the pressure boundary resulting in possible process loss, equipment or environmental damage, or serious personal injury or death.

The specific product design data can be found on the valve's serial plate, data sheet and the calculation sheet (in acc. to the IEC 60534-7:2010).

The noise level emitted by control valves is always determined by the operating data and the installation situation and is different for each application. There is no general typical value for this. In any case, technical measures are used to try to keep this below 80 dB(A). The individually expected pre-calculation noise level can be found in the calculation data sheets.

The Valtek GS handles a wide variety of general service applications, while offering high flow capacity. All sizes come standard with unbalanced trim; for high pressure drop applications optional pressure balanced trim is available for NPS sizes 3 to 6 (DIN size 80 to 150).

The Valtek GS consists of the body, bonnet, trim, and actuator. The valve is designed with a high level of interchangeability allowing the user to assemble the greatest possible number of variations from a minimum number of components to match each application. There are two bonnet designs, standard / extended bonnets and bellows seal bonnets. See *Figure 1* and *Figure 2*.

The Valtek GS is designed in compliance with **EN 1349:2009** - Industrial Process Control Valves (DIN EN 1349 and VDE 0409-1349).

The Valtek FlowTop is designed for use in **MODERATE** and **WORLDWIDE** environmental conditions. However, the intended use of the pneumatic actuators and the accessories is limited by their permissible ambient temperature application

limits. When operated in the moderate range, a service life of 7 to 10 years can be expected before servicing. Leaks can occur at low temperatures (-60°C to -25°C), at high temperatures permanent damage to the elastomers (+60°C to +80°C, expected service life then < 1 year). Humidity up to 93% non-condensing, air pollution up to 300 µg/m³ unless restricted by accessories.

The product offering may include optional ancillary equipment, such as positioners, air-filter regulators, solenoid valves, limit switches or boosters. Digital, I/P, or pneumatic positioners can be mounted directly, with a mounting bracket or according to NAMUR standards. Refer to the relevant manufacturer's user instructions for information regarding other ancillary equipment.

3 Product Identification

Each Valtek GS control valve comes with an attached serial plate which includes key information specifically for each control valve:

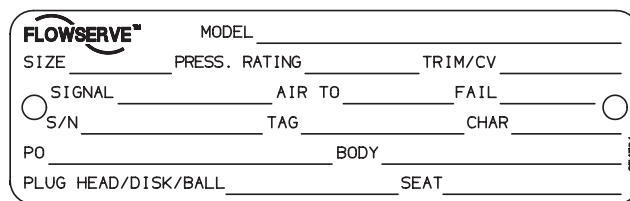

Figure 3: Serial Plate (WW-design, WorldWide)

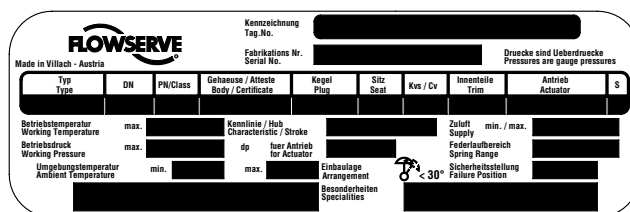

Figure 4: Serial Plate (EU-design, European Union)

The same serial number shown on the plate will appear on all Valtek GS data sheets, dimensional drawings, bills of material, and spare parts lists. Other information located on the serial plate is self-explanatory for the Valtek GS control valve.

You can download .pdf versions of the Valtek GS documentation including a sales brochure, technical bulletin and user instructions at www.flowserve.com. It is the user's responsibility to keep this and related documentation on file and accessible for the Valtek GS product.

4 Valtek GS Modification

Valtek GS control valves are generally delivered as tested and assembled units, with factory-mounted actuators.

Unauthorized modification of the Valtek GS control valve voids the product test certification and product warranties, could drastically affect product performance, and could be hazardous to personnel and equipment.

NOTICE Before Valtek GS re-use, all necessary tests must be repeated and recorded in compliance with all test routines, guidelines and engineering standards.

5 Safety

Safety terms - WARNING and NOTICE - are used to highlight specific dangers and / or provide additional information that may not be readily apparent in the User Instructions. WARNING directions must be strictly followed.

⚠ WARNING or **⚠ WARNING** indicates that severe personal injury, death and substantial property damage can occur if proper precautions are not taken.

NOTICE NOTICE indicates practices or provides additional technical information.

Grey fields indicate safety-related informations.

6 Packaging and Transport

Pay close attention to shipping marks and transport pictograms.

Careful packing, loading and transport arrangements are required to prevent products from being damaged during transport. Standard packaging includes a cardboard box, with or without a wooden pallet base as needed. Special packaging may include a wooden box. Packaging may use cardboard, plastic wrap, foam, or paper as packing material. Filling material may be a carton type or paper.

Shipping marks display product and package dimensions and weight (for further information see Packaging and Sending Instructions, Form L 002). Packing guidelines for export

follow HPE standards. (Nonreturnable packaging may contain up to 90% recyclable materials.)

7 Storage

Maximum storage time for control valves is 6 months.

NOTICE The packing box begins to break down after 6 months. Leakage may develop.

Upon arrival on site, store the Valtek GS on a solid base in a cool, dry closed room. Until its installation, the valve must be protected from the weather, dirt and other potentially harmful influences.

Do not remove the protective covers from the body flanges of the control valve or from the instrument ports of the actuator and accessories until the valve is ready for installation at the site.

8 Unpacking

Hoisting and lifting are inherently dangerous activities and require safe rigging and proper training to mitigate hazards. Use standard industry safety practices, personal protection, and warranted lifting devices.

⚠ WARNING Crushing hazard ! Arrange rigging to prevent tipping of the control valve. Do not allow the valve assembly to rotate during removal. Do not stand under suspended loads. Failure to do so can cause serious personal injury and damage the valve or nearby equipment.

NOTICE Be aware that the center of gravity may be above the lifting point. Do not allow the sling to touch the stem, travel indicator or peripheral equipment. Observe the maximum permitted carrying capacity.

1. Check the packing list against materials received to ensure all components and accessories are present.
2. Place a sling around the valve bonnet just beneath the yoke.

3. You can alternatively hook a triple-leg sling into the lifting rings mounted on the actuator (Actuator sizes 500 and 700 cm²).

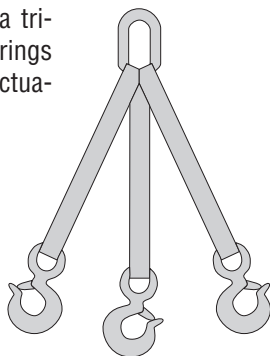

Figure 5: Triple-leg sling

4. Upon removing the control valve from the packaging, we recommend that you:

- Promptly touch up any damage to the corrosion protection.
- Contact your shipper immediately to report any damage.
- Call your Flowserve representative if you experience any problems.
- Do not remove the protective covers from the body flanges of the control valve or from the instrument ports of the actuator and accessories until the valve is ready for installation at the site.

9 Installation

The control valve must be installed and commissioned by qualified staff - personnel who are familiar with the installation, commissioning and operation of this product and possess the relevant qualifications in their field of activity.

! Prior to installation of the valve, we require, that you check the following conditions to reduce the risk of malfunction and safety related incidents.

No.	Check	Possible malfunction or safety related incident
1	Confirm that the nominal / operational data on the serial plate matches the operational data of the facility.	<i>An operational mismatch can cause considerable damage to the valve or may lead to a failure at the facility.</i>
2	Confirm that the line is clear of dirt, welding slag, chips, scale or other foreign material.	<i>The risk of control valve damage due to foreign particles will be reduced if a suitable strainer is installed upstream of the valve. (Suggested mesh size of 0.004 inch (0,1 mm))</i>
3	Confirm the piping flanges are coaxial, parallel, and correspond with the face-to-face dimension of the valve.	<i>Incompatible sizing may result in excessive tension, valve malfunction or flange connection leakage.</i>
4	Confirm the piping is routed correctly and the valve is free of additional piping forces.	<i>Incorrect routing may result in leakage and / or potential valve failure.</i>
5	Confirm that the control valve can be installed in an upright position whenever possible.	<i>Non-upright positioning may increase wear in the packing, resulting in leakage and premature wear.</i>

Table 1: Basic safety messages for installing the valve (continued on next page 6)

No.	Check	Possible malfunction or safety related incident																				
6	<p>Confirm the actuator has enough overhead clearance to disassemble the plug from the valve body.</p> <table border="1"> <thead> <tr> <th rowspan="2">Actuator Code</th> <th colspan="2">Removal Space</th> <th colspan="2">≈ R</th> </tr> <tr> <th>mm</th> <th>inch</th> <th>mm</th> <th>inch</th> </tr> </thead> <tbody> <tr> <td>253</td> <td rowspan="3">180</td> <td rowspan="3">7.1</td> <td>260</td> <td>10.2</td> </tr> <tr> <td>503</td> <td>290</td> <td>11.4</td> </tr> <tr> <td>701</td> <td>330</td> <td>13.0</td> </tr> </tbody> </table>	Actuator Code	Removal Space		≈ R		mm	inch	mm	inch	253	180	7.1	260	10.2	503	290	11.4	701	330	13.0	<p>Figure 6: Overhead clearance drawing</p>
Actuator Code	Removal Space		≈ R																			
	mm	inch	mm	inch																		
253	180	7.1	260	10.2																		
503			290	11.4																		
701			330	13.0																		
7	<p>Confirm there are suitable piping lengths upstream and downstream of the valve installation site in order to minimize a sudden pressure surge in the flow.</p>	<p><i>Absence of suitable piping lengths can create critical operating conditions and cause unacceptable levels of noise and vibration.</i></p>																				
8	<p>Confirm removal of all hazards and ensure appropriate protective measures are in place.</p>	<p><i>none</i></p>																				
9	<p>Confirm flow direction to ensure the correct valve installation. Flow direction is indicated by the arrow on the valve body.</p>	<p><i>Improper flow direction causes critical changes to operating conditions that may damage the control valve.</i></p>																				
10	<p>Confirm that the air supply and instrument signal lines are dry and clear of dirt and oil.</p>	<p><i>At a minimum, the instrument air must conform to ISA-7.0.01-1996 (ISO 8573-1 Compressed Air - Class 2) requirement or those of the accessory manufacturer.</i></p>																				
11	<p>Confirm the valve is grounded in order to prevent an electrical discharge.</p>	<p><i>Noncompliance may result in electrical discharges.</i></p>																				
12	<p>Throttling control valves are typically equipped with a pneumatic actuator and valve positioner. Refer to the appropriate positioner manual for connections and maximum air supplies.</p>	<p><i>The air supply must be limited to less than 87 psig (6 bar) per the actuator serial plate. An air filter regulator should be installed to ensure that the supply pressure to the pneumatic actuator does not exceed the air supply pressure indicated on the EU serial plate.</i></p>																				

Table 1: Basic safety messages for installing the valve

6 After these requirements are confirmed the valve can be installed and connected in the piping.

1. Remove the protective flange covers and coating from the control valve; clean the flange gasket surface.

NOTICE *Unsuitable cleaning agents can damage and cause leakage in PTFE and graphite gaskets. Consult a current chemical resistance list before applying.*

2. Install the control valve in an upright position whenever possible. Vertical installation permits easier valve maintenance.

3. Install and connect the control valve to the pipeline. Locate gaskets in the center of the body flanges and secure nuts and bolts.
4. Connect the power supply and instrument signal lines.
 - For pneumatic actuators, connect the air supply and instrument signal lines.
 - For electric actuators, connect the power supply using the wiring diagram located on removable actuator cover or in the manufacturer's actuator documentation.

10 Valve Quick-Check

Apply appropriate personal protective equipment when working on the control valve to prevent hazards arising from the operation. Protect yourself against freezing, burns and cuts by wearing appropriate protective clothing, gloves and eye protection.

Do not over-tighten packing.

Sudden exposure of the control valve to full working pressure and temperature may cause stress cracks.

⚠ Prior to valve operation, we require, that you check the following conditions to reduce the risk of malfunction and safety related incidents.

No.	Important information	Possible malfunction or safety related incident
1	Avoid critical operating conditions where excessive noise or vibration levels might occur.	<i>Impermissible continuous operation of a control valves under critical conditions can damage the valve.</i>
2	Avoid frequent system start-ups and shutdowns.	<i>Critical operating conditions, which can damage the control valve, may be encountered during system start-up or shut down.</i>
3	Keep the operating medium free of foreign particles.	<i>Installing a suitable strainer upstream of the control valve can prevent foreign particles from damaging the valve.</i>
4	Instrument air must conform to ISA 7.0.01-1996 (with a dew point at least 18°F (10°C) below ambient temperature, particle size below 1 µm and oil content not to exceed 1 ppm)	<i>Contaminated instrument air can damage the accessories and control valve or cause them to fail.</i>
5	⚠ Do not touch the body and bonnet ! The temperature of the operating medium is transferred to the surface of the control valve.	Excessive hot surface temperatures can put you at risk for burns. Frigid surface temperatures can put you at risk for freezing.
6	⚠ Critical operating conditions can cause excessive or hazardous levels of vibration or noise.	Impermissible levels of vibration can cause hearing loss, vascular and nerve damage and damage to joints and bones. Use hearing protection when noise levels exceed 80 dB(A).
7	⚠ Incorrect maintenance can result in the emission of hot, cryogenic, and / or toxic operating media.	Incorrect maintenance can put you at risk for heat related burns, freezing, acid burns or poisoning.

Table 3: Basic safety messages for operating the valve

WARNING Due to risk of crushing hazard, do not work between the yoke legs while the valve is in operation.

Prior to start-up, we strongly recommend that you:

1. Stroke the valve and compare the plug position indicator on the stem clamp to the stroke indicator plate. The plug should change position in a smooth, linear fashion.

NOTICE Graphite packing commonly creates more friction than other materials, such as PTFE. If over tightened, excessive friction may impair smooth control.

2. Adjust instrument signals to ensure a full stroke.
3. Check the packing box bolting to ensure the correct adjustment (See Section 11: Valve Maintenance).

NOTICE Over tightening can cause excessive packing wear and high stem friction that may impede plug movement.

4. Continuously increase load until operation parameters are reached.
5. Minor relaxation of the flange bolting is possible after initial assembly. Retorque the bonnet flange bolting if necessary before installation or following an initial temperature excursion to ensure the bonnet gaskets do not leak (See Table 4).

Size	Pressure	PN 40		Class 150		Class 300	
		Nm	ft lb	Nm	ft lb	Nm	ft lb
15	1/2"	12,5	9.2	7,3	5.4	9,2	6.8
20	3/4"						
25	1"						
32	-	26	19.2	-	-	-	-
40	1 1/2"			17	12.5	21	15.5
50	2"	19	14.0	22	16.2	27	19.9
65	-	51	37.6	-	-	-	-
80	3"			26	19.2	43	31.7
100	4"	78	57.5	46	33.9	76	56.0
125	-	110	81.1	-	-	-	-
150	6"	140	103.3	76	56.0	146	107.7

Table 4: Recommended Body Bolt Torque Values

11 Valve Maintenance

Maintenance intervals and service life of a valve can only be determined empirically on site. The intervals specified in the User Instructions are recommendations and serve only as a guide. Under problematic operating conditions, maintenance intervals may be significantly reduced. We strongly recom-

mend a site survey followed by establishing a documented procedure for performing the maintenance work. Maintenance personnel should perform and log the work accordingly. The data collected can be used as a basis for dynamically determining the maintenance intervals and activities.

Recommended Maintenance Actions					
No.	Service	Inter-val	Valve Condition		
			Good	Adequate	Inadequate
1	Visual inspection of the valve	Bi-weekly	No action	Clean valve stem with a soft cloth	Overhaul or replace valve after product lifecycle
2	Visual inspection of the packing	Bi-weekly	No action	Retighten leaky packing box	Replace leaky packing box immediately
	Preventive change of the PTFE-packing	→	Dependent upon results of previous maintenance (see numbers 1 and 2 above) or a minimum of once every 24 months		
	Preventive change of the Graphite-packing	→	Dependent upon results of previous maintenance (see numbers 1 and 2 above) or a minimum of once every 18 months		
3	Visual inspection of body bolting	Yearly	No action	Retighten body bolting if bonnet gasket leaks.	Remove from service and replace body bolting immediately if gasket leakage persists or if bolting is damaged
4	Visual inspection of the actuator	Bi-weekly	No action	Clean actuator stem with a soft cloth	Overhaul or replace actuator after product lifecycle
	Electric gear actuator	→	No action; gear is lubricated for lifetime; overhaul or replace gear / actuator after product lifecycle		

No.	Service	Inter-val	Valve Condition		
			Good	Adequate	Inadequate
5	Preventive overhaul of the valve	→	Dependent upon results of previous maintenance (see numbers 1 to 4 above) or a minimum once every 60 months		
6	Operation test	→	No action	Perform 3 full strokes if packing and / or bonnet tightening is modified; check for leakage	
Recommended maintenance actions using the Logix digital positioner with ValveSight diagnostic solution software					
7	Visual inspection of diagnostic interface	Weekly	No action - valve is healthy	Take action per warning	Overhaul or replace required part per alarm
8	Check health parameter of valve	Warn-ing	No action - valve is healthy	Replace packing box components per warning	Overhaul or replace valve after alarm
9	Check health parameter of actuator	Warn-ing	No action - actuator is healthy	Check and retighten air supply	Overhaul or replace actuator after alarm
10	Check health parameter of control	Warn-ing	No action - control is healthy	Overhaul or replace valve; trim and bonnet components must be checked and / or repaired after alarm	
11	Check health parameter of positioner	Warn-ing	No action - positioner is healthy	Start step test	Overhaul or replace positioner after alarm

Table 5: Service activities check list

! Prior to valve maintenance, we require, that you check the following conditions to reduce the risk of malfunction and safety related incidents.

No.	Check	Possible malfunction or safety related incident											
1	Check the packing follower for proper tightness.	<p>The packing follower is spring loaded and factory adjusted. If leakage is detected around the packing follower tighten it clockwise using a wrench in quarter turn intervals until the leakage stops.</p> <table border="1"> <thead> <tr> <th>Wrench Size</th> <th>Adjustment Interval</th> <th>Maximum Adjustment</th> </tr> </thead> <tbody> <tr> <td>SW 24</td> <td>~ 15/16 AF</td> <td rowspan="2">quarter turn</td> </tr> <tr> <td>SW 32</td> <td>~ 1 1/4 AF</td> </tr> <tr> <td>SW 46</td> <td>~ 1 13/16 AF</td> <td>one complete turn</td> </tr> </tbody> </table> <p>Table 7: Packing Adjustment</p> <p>Do not overtighten packing.</p> <p>Overtightened packing can cause excessive packing wear and high stem friction that may impede plug movement.</p> <p>If leakage cannot be stopped, the packing must be replaced.</p>	Wrench Size	Adjustment Interval	Maximum Adjustment	SW 24	~ 15/16 AF	quarter turn	SW 32	~ 1 1/4 AF	SW 46	~ 1 13/16 AF	one complete turn
Wrench Size	Adjustment Interval	Maximum Adjustment											
SW 24	~ 15/16 AF	quarter turn											
SW 32	~ 1 1/4 AF												
SW 46	~ 1 13/16 AF	one complete turn											
2	Check for signs of gasket leakage through the bonnet and end flanges.	Tighten the bonnet bolting nuts. See Section 13: Disassembly and Reassembly for instructions. Also see Table 4 in Section 10.											
3	Check if all nuts and bolts are securely fastened.	! Avoid critical operating conditions if excess noise or vibration levels occur during operation.											
4	Check valve for smooth, full-stroke operation. Unsteady stem movement could indicate an internal valve problem.	Internal valve failure requires an immediate overhaul or control valve replacement by qualified staff.											

Table 6: Basic safety messages for maintenance the valve

After these requirements are confirmed proceed with valve maintenance.

WARNING **Crushing hazard ! Failure to keep hands, hair, and clothing away from all moving parts when operating the control valve can cause serious injury.**

1. Clear all dirt and / or foreign material from the plug stem and control valve.
2. If leakage is detected, retighten the packing follower by one full turn clockwise (See Table 7: Packing Adjustment).
3. If retightening packing does not stop the leakage, overhaul the control valve and replace the packing (See Section 13: Disassembly and Reassembly).
4. If leakage is detected, retighten bonnet and flange bolting.

5. Make sure all nuts and bolts are securely fastened.
6. If possible, stroke the valve and check for smooth, full-stroke operation. Unsteady stem movement could indicate an internal valve problem.
7. Make sure all accessory brackets and bolting are securely fastened.
8. Check control valve health parameters:
 - Characteristic curves of the valve with flow
 - Upstream pressure
 - Downstream pressure

into the control room.

NOTICE *Monitor trim and bonnet components. If nominal and actual values differ by more than 5%, an overhaul may be required.*

12 Troubleshooting

Contact customer service department or contract partner for any fault or defect found, otherwise the manufacturer’s guarantee shall be rendered null and void and the manufacturer released from any responsibility. If the user performs the repairs, these User Instructions must be adhered to and carried out in a competent manner. Original Equipment Manufacturer spare parts must be used to make the repair.

Defect	No.	Possible Causes	Remedy
Stem does not move	1.1	• No auxiliary energy supply (pneumatic air or electrical power) to actuator and accessories (positioner, air filter regulator, solenoid valve, limit switch, and/ or special accessories)	<ul style="list-style-type: none"> • Pneumatic actuators: Check supply for leaks Check air pressure (usually 87 psig; 6 bar) • Electrical actuators: Check power supply (connections, circuit breakers, voltage)
	1.2	• Mounted accessories do not work	• See User Instructions for accessory manufacturer
	1.3	• Pneumatic actuator is defective	• Contact customer service department or contract partner
	1.4	• Electric actuator is defective	• See user instructions of the actuator manufacturer
	1.5	• Excessive tightening of the packing box	<ul style="list-style-type: none"> • Loosen packing follower until valve operates properly <p>NOTICE ! Make sure there are no leaks.</p>
	1.6	• Valve trim worn or stuck	• Contact customer service department or contract partner
Jerky stem movement	2.1	• Damaged stem	• Contact customer service department or contract partner

Defect	No.	Possible Causes	Remedy
Jerky stem movement	2.2	• Electric actuator is defective	• Clean stem with suitable cleaning agent
	2.3	• Actuator not powerful enough	• Compare actuator specifications on the serial plate with operation specifications of the facility. If incompatible, contact customer service department or contract partner
Stem travel less than full stroke (0 to 100 %)	3.1	• Air supply pressure too low	• Provide air at the pressure stated on the serial plate (European production only).
	3.2	• Pneumatic actuators: Improper handwheel position	• Move handwheel to limit position , otherwise contact factory for information.
	3.3	• Electric actuators: Limit switches are out of adjustment	• Readjust limit switch to actuator manufacturer's specification
	3.4	• Improperly adjusted or defective positioner	• Readjust positioner to positioner manufacturer's specification
	3.5	• Foreign particles in valve seat or damaged trim	• Contact customer service department or contract partner
Excessive valve seat leakage	4.1	• Damaged sealing surfaces on valve seat or plug	• Contact customer service department or contract partner
	4.2	• Foreign particles in seat area	• Contact customer service department or contract partner
	4.3	• Plug does not close fully	• Refer to No. 3.1 to 3.5
Leaking packing box system	5.1	• Compression force on packing box too low	• Slightly retighten packing box NOTICE ! Make sure stem can still move.
	5.2	• Worn packing	• Slightly retighten packing box NOTICE ! Make sure stem can still move. If the packing does not stop leaking, contact customer service department or contract partner
	5.3	• Dirty stem	• Clean stem with suitable cleaning agent
	5.4	• Damaged stem	• Contact customer service department or contract partner
Leaking bonnet gasket	6.1	• Gasket compression is too low	• Properly retighten bonnet bolting nuts crosswise
	6.2	• Gasket defective	• Contact customer service department or contract partner
	6.3	• Corrosion	• Contact customer service department or contract partner
Leaking body	7.1	• Corrosion or high velocity related damage	• Contact customer service department or contract partner
No limit switch signal	8.1	• Power supply to limit switch interrupted	• Check power supply (connections, circuit breakers, voltage)
	8.2	• Limit switch out of adjustment	• Readjust limit switch operating distance; see limit switch data sheet
Unstable positioner	9.1	• Defective positioner	• See user instruction of the positioner manufacturer

Table 8: Trouble-shooting

13 Disassembly and Reassembly

The Valtek GS control valve is allowed to be disassembled and reassembled only by qualified staff - personnel who are familiar with disassembling, reassembling, installation and commissioning of this product, and possess the relevant qualifications in their field of activity.

When performing repairs, personnel are to follow these instructions using only **original** equipment manufacturer (OEM) spare parts and recommended special tools to ensure the reliability of the Valtek GS control valve.

Only Flowserve trained and authorized personnel are allowed to repair (disassemble and reassemble) the Valtek GS in hazard areas.

Valves are provided for oil and grease-less service or oxygen service may only disassembled and reassembled in clean rooms (ISO 14644- ISO 8, US FED STD 209 E - M 6.5, or equivalent).



WARNING

Control valves are pressure vessels.

Improper opening of the valve or actuator can result in bodily injury.

! Prior to disassemble and reassemble, we require, that you check the following conditions to reduce the risk of malfunction and safety related incidents.

No.	Important information	Possible malfunction or safety related incident
1	Disregarding these instructions may bring serious or harmful consequences.	<i>Failure to comply with these user instructions will render the manufacturer's guarantee and liability null and void. Unless otherwise agreed, the manufacturer's general terms and conditions of sale shall apply.</i>
2	! Always observe system safety instructions when preparing for and performing the repair procedure.	Potential hazards and their sources are under the operator's influence. The operator must observe national and international environmental regulations for control valve removal from the pipe and cleaning. Permissible exposure limits must be maintained, appropriate personal protective equipment must be used and service personnel must be properly instructed in performing the repair procedure.
3	! Make sure the pipeline is depressurized and in ambient state, also a suitable rigging (e.g. Endless Sling) and securing devices (e.g. Vee Trough with Stands / Vise) are readily available.	Remove the Valtek GS from the pipeline in a depressurized and ambient state. Failure to do so can cause serious personal injury. The control valve is not equipped with integral stands, therefore guard against the valve from tipping over. Bodily injuries can be the result. Use appropriate clamps, blocking or other stabilizing support. Attachment to overhead crane can ensure stability.
4	Confirm that you have the required spare parts at the site.	<i>Not having the full complement of parts, accessories and tools can slow or stop repair work.</i>
5	! Confirm that you have the required tools available to manage the disassembly and reassembly (See Section 16: Special Tools).	Improper tools and / or improper use of tools can result in personal injury or damage to the parts.
6	Review the serial plate information to identify the valve. The serial number and the part numbers needed are required when ordering spare parts.	<i>A serial plate used for product identification is attached on every control valve (See Section 3: Product Identification).</i>
7	Do not damage any valve surfaces during repair.	<i>Damaging the stem surface and / or packing area may lead to premature leakages in the packing area.</i>
8	Check all parts for damage such as scoring, deformities, corrosion or overexpansion.	<i>If in doubt, replace faulty parts. Never reuse gaskets.</i>

Table 9: Basic safety messages for repairing the control valve

After these requirements are confirmed the control valve can be maintained and repaired.

Description of the Procedure

1. Disconnect the air supply from the actuator and / or assembled accessories.
2. Disassemble the positioner from the valve as necessary (See Figure 7: Remove the positioner).
3. Move the actuator to the open (retracted) position.
4. Turn the lock nut (113) clockwise to loosen. Keep upper coupling (249) from turning by securing with a wrench (See Figure 8: Remove the actuator).
5. Turn the cap screws (240) counter clockwise to loosen.
6. Turn the yoke lock nut (76) counter clockwise to loosen.
7. Lift off and store the actuator safely.
8. Place the valve body assembly on a table for disassembly.

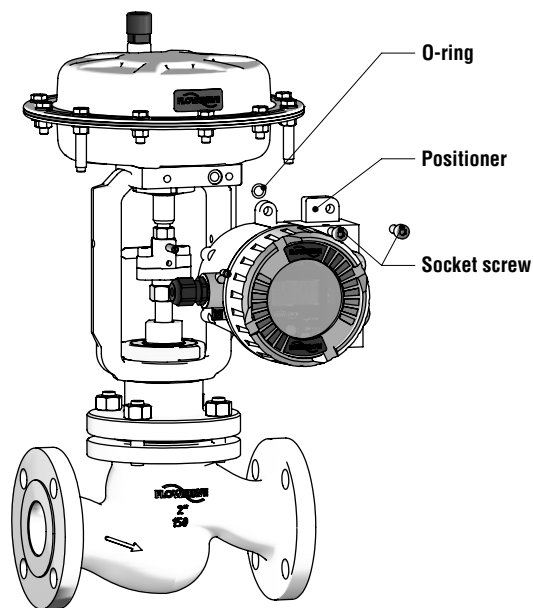

Figure 7: Remove the positioner

Disassembly instructions of the valve body assembly (standard or extended bonnet design).

1. Turn the bonnet nuts (114) counter clockwise to loosen (See Figure 9: Disassemble / Reassemble the valve).
2. Turn the packing follower (80) counter clockwise to loosen.
3. Remove the Belleville springs (109).
4. Remove the upper stem guide (87).
5. Place the Ring Nut Tool (See Section 16: Special Tools) on the stem (50) and turn slowly.

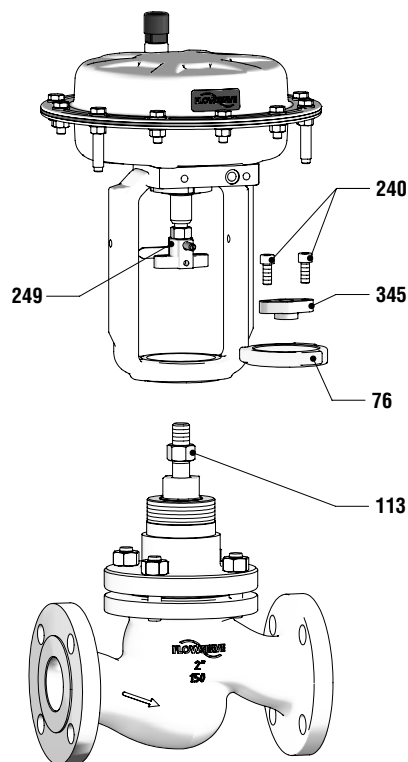

Figure 8: Remove the actuator

WARNING Crushing hazard ! Lifting the bonnet and plug from the control valve involves personal physical risk by falling parts.

Please exercise caution.

NOTICE Exercise care with a pressure balanced plug design. While removing the pressure balanced plug the cage may stick to the plug head then become detached while lifting the plug and stem out of the valve. Secure the cage as you remove the plug and stem.

Item		Part	Item		Part
WW ¹⁾	EU ²⁾		WW	EU	
76	5.10	Yoke lock nut	249	5.3	Upper coupling
113	5.2	Lock nut	345	5.1	Lower coupling
240	5.5	Cap screw			

Table 10: Coupling parts identification

¹⁾ WorldWide ²⁾ European Union

6. Remove the bonnet gasket (58).
7. Insert the Seat Change Tool (See Section 16: Special Tools) into the body of the valve until the pin clicks into place. Use a suitable torque wrench to remove the seat ring.
8. Remove the seat ring (20) and profile ring (55).
9. Remove the plug (50) from the bonnet (40).
10. Use the Packing Driver Tool (See Section 16: Special Tools) to remove the packing (88) and the packing box ring (93).
11. Use a standard brass scraper or other suitable tool to remove all old gasket material; then clean the gasket surfaces.

NOTICE Examine the valve trim and bonnet components. If the nominal and actual values differ by more than 5% a control valve overhaul may be required (See Point 8, Page 9).

12. Check stressed surface areas for damage such as scoring and deformities.
13. Use a standard brass scraper or other suitable tool to clean bolting. Check for corrosion or any other damage.

Reassembly instructions of the valve body assembly (standard or extended bonnet design).

14. Lubricate all bolt and screw threads and bearing surfaces (stem, underside of the nuts) with a suitable, approved lubricant (See Section 15: Lubricants).

NOTICE Never allow lubricants to come in contact with the bonnet or sealing surfaces.

15. Install and finger tighten a new profile ring (55) and seat ring (20).
16. Insert the Seat Change Tool (See Section 16: Special Tools) into the body of the valve and turn clockwise using a suitable torque wrench (See Section 14: Required Torque, for screwed seat rings).
17. Lower the plug (50) into the body and place it into the seat ring (See page 18 for pressure balanced and MultiStream trim).
18. Install the new bonnet gasket (58).
19. Carefully lower the bonnet (40) onto the plug in the

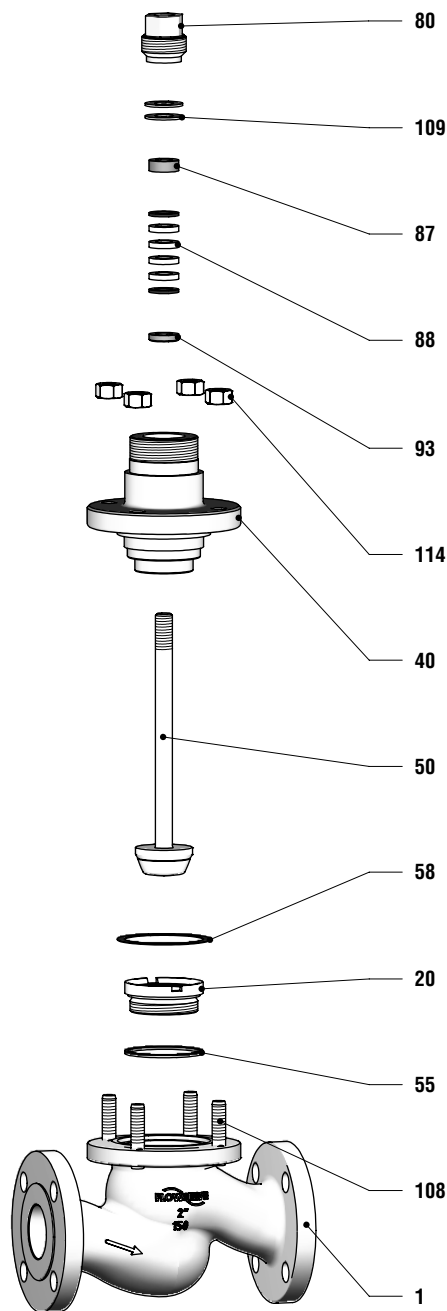

Figure 9: Disassemble / Reassemble the valve

Item	Part	Item	Part
1	Body	87	Upper stem guide
20	Seat ring	88	Packing
40	Bonnet	93	Packing box ring
50	Plug	108	Stud bolt
55	Bonnet gasket	109	Belleville spring
58	Bonnet gasket	114	Hex nut
80	Packing follower		

Table 11: Valve parts

body of the valve.

20. Install and finger tighten the bonnet nuts (114) to the bonnet bolts (108).
21. Install the packing box ring (93) and the new packing (88).

NOTICE *Install and push two packing rings consecutively using the Tamping Tool and pre-tighten it using the Compression Tool. Repeat the procedure with remaining rings. Rotate each ring 180° from the overlapping point. Make sure each ring is clean. Dirty rings result in stem leakage.*

(See Table 18, Page 23)

22. Install the upper stem guide (87), Belleville springs (109), and the packing follower (80). Tighten the packing follower with your fingers clockwise until resistance can be felt.

NOTICE *The belleville springs (109) must be stacked in series.*

23. Tighten the bonnet nuts (114) in four steps - 30%, 60%, 100%, and all around 100% - using a crosswise pattern (See Section 14: Torque Requirements).

NOTICE *Check the plug's freedom of movement by lifting it approximately ~10 mm (0.4 inch) between tightenings. Loosen the bolted connection and start again if it proves difficult to move the plug.*

24. Finish packing follower tightening with a wrench (See Table 7, Page 9).

NOTICE *Do not over tighten the packing. Over tightened packing may produce higher friction and reduce product service life.*

25. Replace the pneumatic diaphragm or multi-turn actuator and accessories (See page 19).
26. After reinstalling the control valve in the pipeline, perform 3 full strokes and check the tightening of the packing follower and bonnet bolting.
27. Log the maintenance interval and the work performed.

Disassembly of the valve with a Bellows Seal Bonnet Assembly.

1. Turn the bonnet nuts (114) counter clockwise to loosen (See Figure 10: Disassemble / Reassemble the valve with bellows seal bonnet type A).

2. Turn the packing follower (80) counter clockwise to loosen.
3. Remove the Belleville springs (109).
4. Remove the upper stem guide (87).
5. Place the Ring Nut Tool (See Section 16: Special Tools) on the stem (50) and turn slowly.

WARNING **Crushing hazard ! Lifting the bonnet and plug from the control valve involves personal physical risk by falling parts.**

Please exercise caution.

NOTICE *Exercise care with a pressure balanced plug design. While removing the pressure balanced plug the cage may stick to the plug head then become detached while lifting the plug and stem out of the valve. Secure the cage as you remove the plug and stem.*

6. Remove the bonnet gasket (58).
7. Insert the Seat Change Tool (See Section 16: Special Tools) into the body of the valve until the pin clicks into place. Use a suitable torque wrench to remove the seat ring.
8. Remove the seat ring (20) and profile ring (55).
9. Turn the bonnet nuts (110) counter clockwise to loosen.
10. Remove the head (7) and upper bonnet gasket (59).

NOTICE *There are two different bellows seal designs.*

Type	Size	Twist lock between plug and stem	Connection between bellows and bonnet
A	15 - 50	1/2" - 2"	Lock bushing Clamped
B	65 - 150	3" - 6"	Lock pushing Screwed

Table 12: Bellows seal bonnet types

11. Disassembling each type of Bellows Seal Assembly:

Type A Bellows Seal Assembly:

Lower the plug (50) into a three jaw-chuck with soft brackets and turn the plug from the stem and bonnet (6 / 40) counter clockwise to loosen then move the bellows seal assembly up and out.

Type B Bellows Seal Assembly:

Turn the hex nut (113) from the bellows seal assembly (6) counter clockwise to loosen, remove the seal carrier (91) and profile ring (60) then move the bellows seal assembly down and out.

NOTICE *The bolting between plug and stem are secured against twisting. Type A and B bellows seal assemblies are secured with a lock bushing (8).*

12. Use the Packing Driver Tool (See Section 16: Special Tools) to remove the packing (88) and the packing box ring (93).

13. Use a standard brass scraper or other suitable tool to remove all old gasket material; then clean the gasket surfaces.

NOTICE *Examine the valve trim and bonnet components. If the nominal and actual values differ by more than 5% a control valve overhaul may be required.*

14. Check stressed surface areas for damage such as scoring or deformities.

15. Use a standard brass scraper or other suitable tool to clean all bolting. Check for corrosion or any other damage.

Reassembly of the valve with a Bellows Seal Bonnet Assembly:

16. Lubricate all bolt and screw threads and bearing surfaces (stem, plug, underside of the nuts) with a suitable, approved lubricant (See Section 15: Lubricants).

NOTICE *Never allow lubricants to come in contact with the bonnet or sealing surfaces.*

17. Install and finger tighten a new profile ring (55) and seat ring (20).

18. Insert the Seat Change Tool (See Section 16: Special Tools) into the body of the valve and turn clockwise using a suitable torque wrench (See Section 14: Required Torque, for screwed seats).

19. Lower the plug (50) into a three jaw-chuck with soft brackets and install a new lock bushing (8) into the plug (Type A and B).

NOTICE *The cone of the lock bushing must open to the top.*

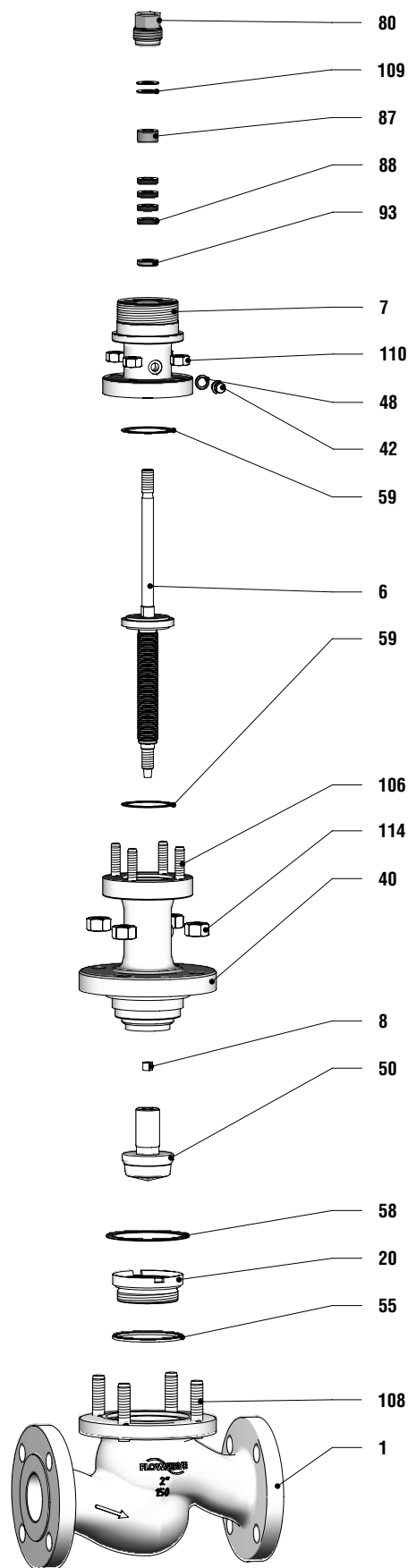

Figure 10: Disassemble / Reassemble the valve with bellows seal assembly for type A designs (Valve parts see Table 13, Page 17)

Reassembling **Type A** bellows:

Carefully lower the bonnet (40) onto the plug. Install a new head gasket (59) and insert the bellows seal assembly (6) from the top of the bonnet (40). Finger tighten the stem (6) clockwise onto the plug (50). Tighten the stem (6) using a suitable torque wrench.

Reassembling **Type B** bellows:

Install the bellows seal assembly (6) clockwise onto the plug (50). Tighten the stem (6) using a suitable torque wrench.

Insert the bellows seal assembly (6) type B through the underside of the bonnet (40), install a new profile ring (60) and seal carrier (91) on top. Turn hex nut (60) clockwise and finger tighten. (See Section 14: Required Torques, for plug and stem)

20. Install the new bonnet gasket (58).
21. Carefully lower the pre-assembled bonnet in the body of the valve (See page 18 for pressure balanced and MultiStream trim).
22. Install and finger tighten the bonnet nuts (114) to the bonnet bolts (108).
23. Install the new flat gasket (59).
24. Carefully lower the head (7) onto the stem and bonnet.
25. Install and finger tighten the nuts (110) to the studs (106).
26. Install the packing box ring (93) and the new packing (88).

NOTICE *Install and push two packing rings consecutively using the Tamping Tool and pre-tighten it using the Compression Tool. Repeat the procedure with remaining rings. Rotate each ring 180° from the overlapping point. Make sure each ring is clean. Dirty rings result in stem leakage.*

(See Table 18, Page 23)

27. Install the upper stem guide (87), Belleville springs (109), and the packing follower (80). Tighten the packing follower with your fingers clockwise until resistance can be felt.

NOTICE *The Belleville springs (109) must be stacked in series.*

28. Tighten the bonnet nuts (114) in four steps - 30%, 60%, 100%, and all around 100% - using a crosswise pattern (See Section 14: Torque Requirements).

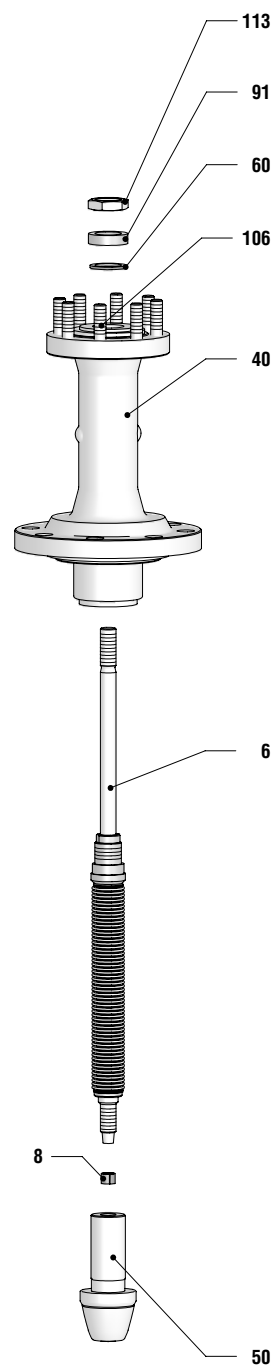

Figure 11: Disassemble / Reassemble the valve with bellows seal assembly for type B design

Item	Part	Item	Part	Item	Part
1	Body	50	Plug	91	Seal carrier
6	Stem	55	Profile ring	93	Packing box ring
7	Head	58	Bonnet gasket	106	Stud bolt
8	Lock bushing	59	Head gasket	108	Stud bolt
20	Seat ring	60	Profile ring	109	Belleville spring
40	Bonnet	80	Packing follower	110	Hex nut
42	Plug screw	87	Upper stem guide	113	Hex nut
48	Plug gasket	88	Packing	114	Hex nut

Table 13: Valve parts with bellows seal

29. Tighten the nuts (110) in four steps - 30%, 60%, 100%, and all around 100% - using a crosswise pattern (See Section 14: Torque Requirements).

NOTICE Check the plug's freedom of movement by pushing / lifting it approximately ~10 mm (0.4 inch) between tightenings. Loosen the bolted connection and start again if it proves difficult to move the plug.

30. Finish packing follower tightening with a wrench (See Table 7, Page 9).

NOTICE Do not over tighten the packing. Over tightened packing may produce higher friction and reduce product service life.

31. Replace the pneumatic diaphragm or multi-turn actuator and accessories (See page 19).

32. After reinstalling the control valve in the pipeline, perform 3 full strokes and check the tightening of the packing follower and bonnet bolting.

33. Log the maintenance interval and the work performed.

Extended plug version with MultiStream noise reduction trim:

1. Lower the multiple orifice cylinder (30) and spring (133) into the body and place it onto the seat.
2. Lower the plug (50) into the body and place it into the seat.
3. Continue with the standard procedure in the corresponding chapter.

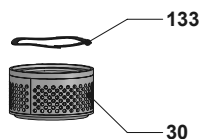

Figure 12: Extended bonnet trim for MultiStream

Item	Part	Item	Part
30	Multiple orifice cylinder	133	Spring

Table 14: Valve parts extended bonnet trim with MultiStream

Extended bonnet version with a pressure balanced or MultiStream trim:

1. Reassembling for the pressure balanced **V-ring**, a new driving band (66) and a new sealing ring (65).

Reassembling for the pressure balanced **Piston-ring**, two new sealing rings (65).

NOTICE Install rings consecutively.

2. Lower the multiple orifice cylinder (30) and cage (31) into the body and place it onto the seat.
3. Install the new cage gasket (56).
4. Lower the plug (50) into the body and place it into the seat.
5. Continue with the standard procedure in the corresponding chapter.

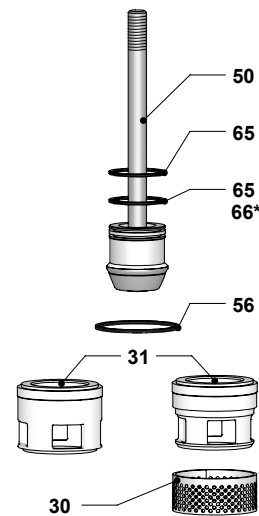

Figure 13: Extended bonnet trim for pressure balanced designs

Item	Part	Item	Part
30	Multiple orifice cylinder	56	Cage gasket
31	Cage	65	Sealing ring
50	Plug	66	Driving band

Table 14: Valve parts extended bonnet trim equipment - balancing and MultiStream

* Type V-ring pressure balanced design with one driving band (65) and one sealing ring (66).

Type Piston-ring pressure balanced design with two sealing rings (65).

Reassemble the actuator and positioner onto the valve:

1. Mount the pneumatic diaphragm or multi-turn actuator onto the bonnet and tighten the yoke lock nut (76) clockwise (See Section 14: Required Torques).

NOTICE *The legs of the yoke should be parallel to the flow direction.*

2. Move the actuator to the open position.
3. Screw in the lower coupling (345) three turns and move the actuator into the closed position.

NOTICE *The plug must be aligned onto the seat. The cushioning effect of the bellows can be prevented by tightening the packing follower.*

4. Move the actuator back into the open position and adjust the distance between the lower coupling (345) and upper coupling (249) by adjusting the stroke length.

Size		Stroke	
15 - 50	1/2" - 2"	20 +0.5 mm	0.787 +0.02 in.
65 - 100	3" - 4"	40 +0.5 mm	1.574 +0.02 in.
125 - 150	6"	60 +0.8 mm	2.362 +0.03 in.

Table 15: Stroke adjustment length

5. Move the actuator to the close position and install the cap screws (240).
6. Lock the lock nut (113). Keep upper coupling (249) from turning by securing with a wrench.
7. Reassemble the positioner on the valve as necessary (See relevant accessory User Instruction).
8. Connect the valve into the pipeline (See Section 9: Installation).
9. After reinstalling the control valve into the pipeline, perform three full strokes and check the tightness of the packing follower and bonnet bolting (See Section 10: Valve Quick-Check).
10. Log the maintenance interval and the work performed.

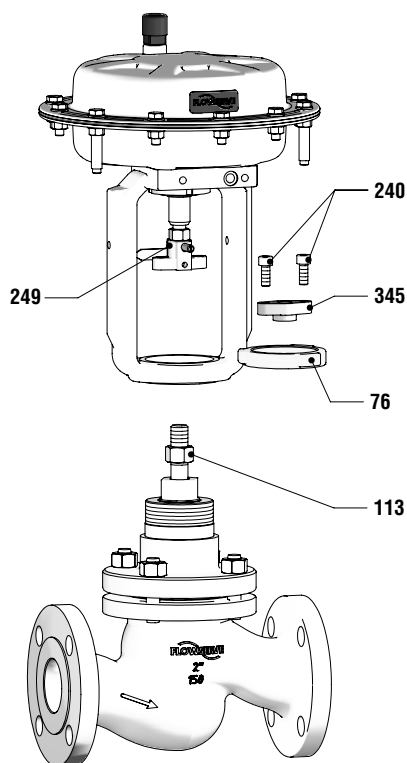

Figure 14: Remove the positioner

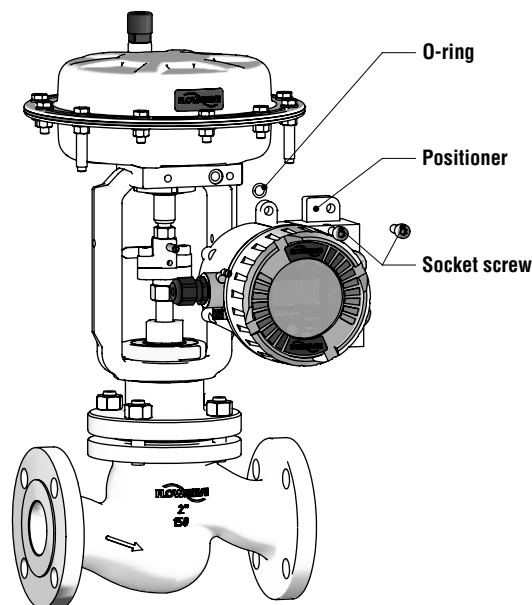

Figure 15: Remove the actuator

Item		Part	Item		Part
WW ¹⁾	EU ²⁾		WW	EU	
76	5.10	Yoke lock nut	249	5.3	Upper coupling
113	5.2	Lock nut	345	5.1	Lower coupling
240	5.5	Cap screw			

Table 16: Coupling parts identification

¹⁾ WorldWide ²⁾ European Union

14 Torque Requirements

Valtek GS Pressure Class		Torque Requirements for BONNET NUTS (58) per nominal diameter										
		15	20	25	32	40	50	65	80	100	125	150
		1/2"	3/4"	1"	-	1 1/2"	2"	-	3"	4"	-	6"
PN 16 / 40	Nm	12,5			26		19	51		78	110	140
Class 150		7,3			-	17	22	-	26	46	-	76
Class 300		9,2				21	27		43	76	-	146
PN 16 / 40	ft lb	9.2			19.2		14.0	38		58	81	103
Class 150		5.4			-	12.5	16.2	-	19.2	34	-	56
Class 300		6.8				15.5	19.9		32	56	108	

Valtek GS Pressure Class		Torque Requirements for SEAT RINGS (20) per nominal diameter										
		15	20	25	32	40	50	65	80	100	125	150
		1/2"	3/4"	1"	-	1 1/2"	2"	-	3"	4"	-	6"
PN 16 / 40	Nm	40			100		162	457		841	1046	1653
Class 150 / 300		30			74		120	337		620	772	1219
PN 16 / 40	ft lb	30			74		120	337		620	772	1219
Class 150 / 300		30			74		120	337		620	772	1219



Valtek GS Pressure Class		Torque Requirements for HEAD NUTS (110) per nominal diameter											
		15	20	25	32	40	50	65	80	100	125	150	
		1/2"	3/4"	1"	-	1 1/2"	2"	-	3"	4"	-	6"	
PN 16 / 40	Nm	13			22						44		
Class 150		10			-	14	-	30		-	24		
Class 300		10				12		25			46		
PN 16 / 40	ft lb	9.6			16.2								
Class 150		7.4			-	10.3	-	22		-	17.7		
Class 300		7.4				8.9		18.4			34		

Valtek GS Pressure Class		Torque Requirements for PLUG and STEM (50, 6) per nominal diameter										
		15	20	25	32	40	50	65	80	100	125	150
		1/2"	3/4"	1"	-	1 1/2"	2"	-	3"	4"	-	6"
PN 16 / 40	Nm	40					80					170
Class 150 / 300		30					59					125
PN 16 / 40	ft lb	30					59					125
Class 150 / 300		30					59					125

15 Lubricants

Application site		Valve - working temperature			Actuator - ambient temperature		
		Standard -40°C to +400°C	Low -60°C to -41°C	Oxygen -40°C to +160°C	Standard -40°C to 80°C	Oxygen	Optionally -60°C to +80°C
Static lubrication / release agents	Valve: Threads of the stem (2.2/2.4) and twist-lock of the stem (2.3), thread of the seat (2.1) and hex nut (2.6); Bonnet-bolting (1.3/1.4) and head-bolting (3.17/3.16)	Klüberpaste HEL 46-450 [Chesterton 785 (FG)]		Klüberalfa YV 93-1202		N/A	
	Actuator: Threads of the packing-follower (3.4), coupling (5.2, 5.1, 5.3, 5.5) and yoke locknut (5.10)	N/A			Klüber Unisilikon L250L	Klüberalfa YV 93-1202 [Fuchs Gleitmo 599]	Klüber Unisilikon L250L
Initial lubrication on sliding surfaces	Valve: Guide of the plug (2.2), V-ring balancing (2.12) Bellows anti-twist device (2.4)	HEL 46-450 [785 (FG)]	without		N/A		
	Actuator: O-ring's (6.17, 6.50, 6.10, 6.51) and guide (6.8.2)	N/A			Klüber Unisilikon L250L	Klüberalfa YV 93-1202 [Gleitmo 599]	Klüberalfa YV 93-1202

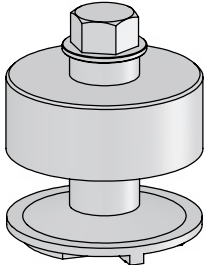
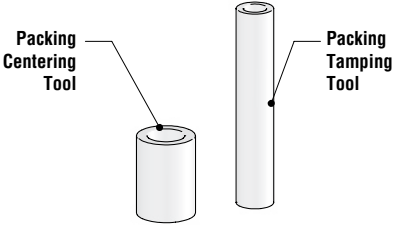
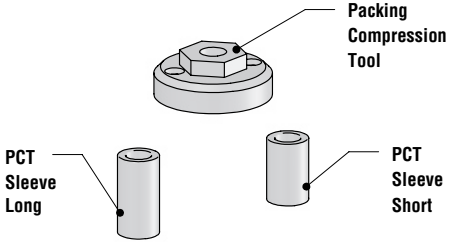
16 Special Tools

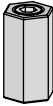
Special Tool	Use
	<p>Seat Change Tool</p> <p>Recommended tool for disassembling and reassembling.</p> <p>Part N° See spare parts catalog</p> <p>Torque wrench cannot afford such needed high torques. Use therefore an mechanical force multiplier - for example JUWEL Type 01 RS or Type 03L or equivalent.</p>
	<p>Packing Tamping Tool</p> <p>Recommended tool for assembling.</p> <p>Part N° See spare parts catalog</p>
	<p>Packing Compression Tool</p> <p>Recommended tool for assembling.</p> <p>Part N° See spare parts catalog</p>
	<p>Ring Nut Tool</p> <p>Recommended tool for disassembling and reassembling.</p> <p>Part N° See spare parts catalog</p>
	<p>Packing Driver Tool</p> <p>Recommended tool for disassembling.</p> <p>Part N° See spare parts catalog</p>
	<p>Stem Tightening Tool</p> <p>Recommended tool for disassembling and reassembling.</p> <p>Part N° See spare parts catalog</p> <p>Alternatively, one can use also an automatic stud driver.</p>

17 Parts List

¹⁾ see page 17, ²⁾ and ³⁾ see page 18

Item		Part	Available Materials				Spare Parts
WW ¹⁾	EU ²⁾						
1	1.1	Body	1.0619	A216 WCC	1.4408	A351 CF8M	
6	2.4	Bellows seal Unit	316 SS				
7	3.15	Head	1.0460 or 1.0619	A105 or A216 WCC	1.4404 or 1.4408	316 L or A351 CF8M	
8	2.3	Lock Bushing	316 SS				
20	2.1	Seat Ring	316 SS				S
30	2.26	Multi. Cylinder ³⁾	1.4571				K
31	2.9	Cage ²⁾	A351 CF8M				
40	3.1	Standard Bonnet Extension Bonnet Bellows Seal Bonnet	1.0460 or 1.0619	A105 or A216 WCC	1.4404 or 1.4408	316 L or A351 CF8M	
42	3.14	Plug Screw	A2				
48	3.13	Gasket	Pure Graphite				D
50	2.2	Contoured Plug Quick Open	316 SS (Alloy 6)				K
55	2.5	Profile Ring	Pure Graphite				S
56	2.10	Cage Gasket ²⁾	Pure Graphite				
58	1.2	Bonnet Gasket	Pure Graphite on Support Plate from 1.4401				D
59	2.15	Head Gasket	Pure Graphite				
60	2.8	Profile Ring ¹⁾	Pure Graphite				
65	2.12	Sealing Ring ²⁾	PTFE-Rings				
66	2.21	Driving Band ²⁾	PTFE				
80	3.4	Packing Follower	316 SS				
83	3.1.1	Lower Stem Guide	316 SS (nitrided)				
87	3.6	Upper Stem Guide	316 SS				
88	3.3	Packing	PTFE-Rings Graphite-Rings				D
91	2.7	Seal Carrier ¹⁾	316 SS				
93	3.2	Packing box ring	316 SS				
106	3.17	Stud Bolt	KG	A193	A2-70	A193	
108	1.3	Stud Bolt	KG	A193	A2-70	A193	
109	3.7	Belleville Spring	1.4310				
110	3.16	Hex Nut	KG	A194	A2-70	A194	
113	2.6	Hex Nut ¹⁾	316 SS				
114	1.4	Hex Nut	KG	A194	A2-70	A194	
133	2.28	Spring ³⁾	1.4568				

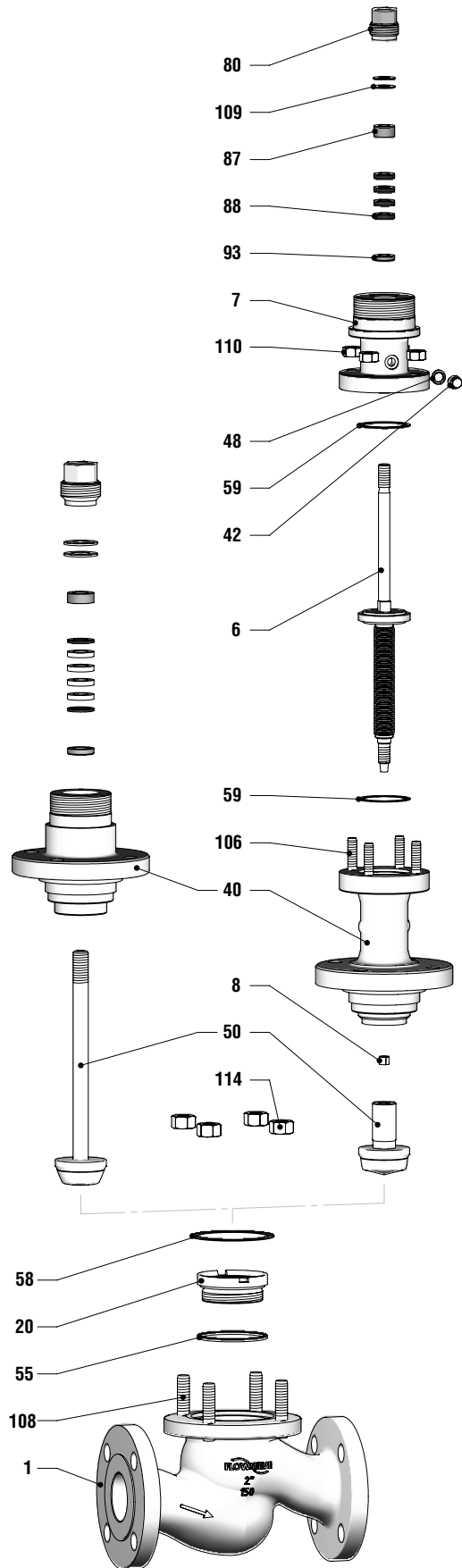

Figure 16: Complete valve parts

Parts List - Packing Details

Part	Detail
	<p>PTFE Packing (88)</p> <p>This consists of:</p> <ul style="list-style-type: none"> 1 Pc. Anti Extrusion Ring 4 Pcs. Packing Rings 1 Pc. Anti Extrusion Ring <p>Rotate each ring 180° from the overlapping point.</p>
	<p>Graphite Packing (88)</p> <p>This consists of:</p> <ul style="list-style-type: none"> 5 Pcs. Packing Rings <p>Rotate each ring 180° from the overlapping point.</p>
	<p>Belleville Springs (109)</p> <p>The two Belleville springs must stacked in series !</p>

Table 17: Packing Details

18 Disposal

Up to 95 % of the Valtek GS control valve is metal. The remaining materials are synthetic, rubber, polytetrafluoroethylene (PTFE), graphite, paint, and lubricants.

The valve should be professionally disassembled and reassembled. Metal parts should be scrapped, with the remaining materials disposed of according the national conditions.

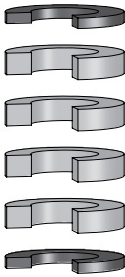
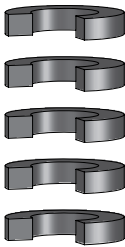
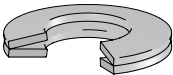
NOTICE *Potential hazards and their sources are under the operator's influence. The operator must observe national and international environmental conditions for control valve removal from the pipeline and cleaning. Permissible limit values must be maintained to ensure suitable protective measures; service personnel must be properly instructed in performing the disassembly and reassembly procedure.*

Peripheral units (accessories) should be recycled according the relevant manufacturer's User Instructions.

**Flowserve Corporation**

No. 35, Baiyu Road
Suzhou Industrial Park
Suzhou 215021, Jiangsu Province, PRC
Phone: +86-512-6288-1688
Fax: +86-512-6288-8737

Flowserve Pte Ltd.

No. 12 Tuas Avenue 20
Singapore 638824
Phone: +65 6879 8900
Fax: +65 6862 4940

Flowserve Corporation

Flow Control Division
1978 Foreman Drive
Cookeville, Tennessee 38501 USA
Phone: +931-432-4021
Fax: +931-432-5518

Flowserve Corporation

Flow Control Division
1350 North Mountain Springs Parkway
Springville, Utah 84663-0913 USA
Phone: +801-373-3028
Fax: +801-489-2228

Flowserve Flow Control (UK) Ltd.

Burrell Road
Haywards Heath
West Sussex United Kingdom
RH16 1TL
Phone: +44-1444-314400
Fax: +44-1444-314401

Flowserve Ahaus GmbH

von-Braun-Str. 19a
48683 Ahaus
Phone: +49-2561-686-119
Fax: +49-2561-686-109

Flowserve Flow Control GmbH

Actuators and Automation Center
Germany
Rudolf Plank Str. 2
D-76275 Ettlingen
Germany
Phone +49 (0)7243-103-0
Fax +49 (0)7243-103-222

Flowserve Flow Control Benelux BV

Rechtzaad 17
4703 RC Roosendaal NB Netherlands
Phone: +31-165-598-800
Fax: +31-165-555-670

Flowserve India Controls Pvt Ltd.

Plot No. 4, 1A, E.P.I.P, Road No. 8
Whitefield, Bengaluru
Karnataka 560066, India

Flow Control Division Brazil

Rua Tocantins, 128
09580-130 - São Caetano do Sul - SP
Brazil

Flowserve Control Valves GmbH

Kasernengasse 6
9500 Villach
AUSTRIA
Telephone: +43 (0) 4242 41 181 - 0
Fax: +43 (0) 4242 41 181 - 50

Flowserve Corporation has established industry leadership in the design and manufacture of its products. When properly selected, this Flowserve product is designed to perform its intended function safely during its useful life. However, the purchaser or user of Flowserve products should be aware that Flowserve products might be used in numerous applications under a wide variety of industrial service conditions. Although Flowserve can provide general guidelines, it cannot provide specific data and warnings for all possible applications. The purchaser/user must therefore assume the ultimate responsibility for the proper sizing and selection, installation, operation, and maintenance of Flowserve products. The purchaser/user should read and understand the Installation Instructions included with the product, and train its employees and contractors in the safe use of Flowserve products in connection with the specific application.

While the information and specifications contained in this literature are believed to be accurate, they are supplied for informative purposes only and should not be considered certified or as a guarantee of satisfactory results by reliance thereon. Nothing contained herein is to be construed as a warranty or guarantee, express or implied, regarding any matter with respect to this product. Because Flowserve is continually improving and upgrading its product design, the specifications, dimensions and information contained herein are subject to change without notice. Should any question arise concerning these provisions, the purchaser/user should contact Flowserve Corporation at any one of its worldwide operations or offices.

©2022 Flowserve Corporation. All rights reserved. This document contains registered and unregistered trademarks of Flowserve Corporation. Other company, product, or service names may be trademarks or service marks of their respective companies.

FCD VLEEIM0300-05 (EN/A4) November 2022