

GROUP 2 (not to scale)

- 3x2-8
- 4x3-8
- 2x1LF-10
- 2x1-10A
- 3x1½-10A
- 3x2-10A
- 4x3-10
- 4x3-10H
- 6x4-10
- 6x4-10H
- 3x1½LF-13
- 3x1½-13
- 3x2-13
- 4x3-13
- 4x3-13HH
- 6x4-13A

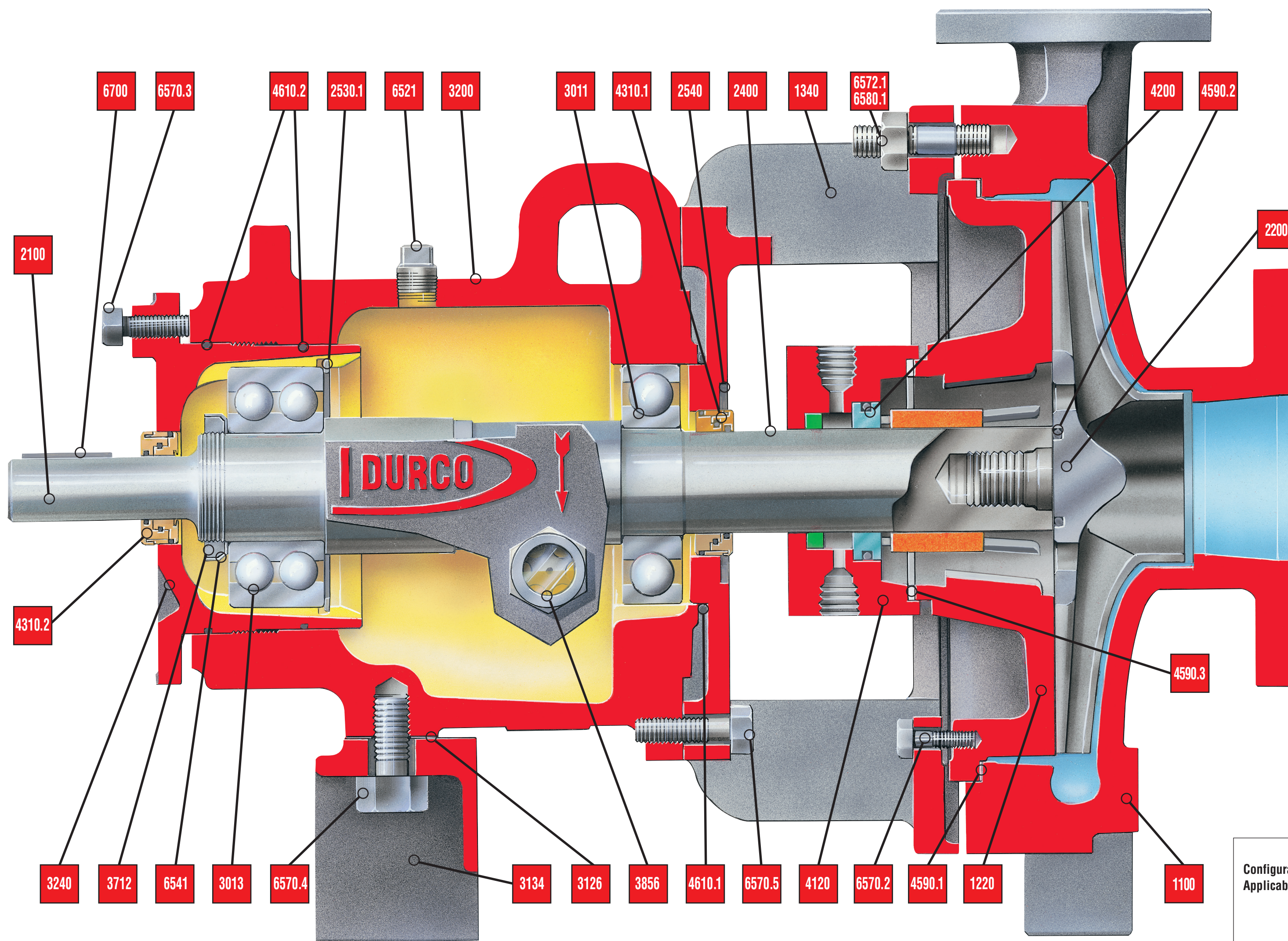

Component Parts

ITEM	DESCRIPTION
1100	CASING
1220	COVER
1340	ADAPTER - BEARING HOUSING
2100	SHAFT
2200	IMPELLER
2400	SLEEVE - Optional
2530.1	RETAINING RING - BEARING
2530.2	RETAINING RING - CLAMP TYPE
2540	DEFLECTOR INBOARD - Optional
2541	OIL FLINGER - Optional, Not Shown
3011	BALL BEARING - INBOARD
3013	BALL BEARING - OUTBOARD
3126	SHIM
3134	SUPPORT FOOT
3200	BEARING HOUSING
3240	BEARING CARRIER
3712	BEARING LOCKNUT
3855	CONSTANT LEVEL OILER - Optional, Not Shown
3856	SIGHT GAGE - BEARING HOUSING
4120	GLAND
4130	PACKING - Optional Not Shown
4134	SEAL CAGE - W/Packing Not Shown
4200	MECHANICAL SEAL
4310.1	OIL SEAL - INBOARD
4310.2	OIL SEAL - OUTBOARD
4590.1	GASKET - COVER
4590.2	GASKET - IMPELLER
4590.3	GASKET - GLAND
4610.1	O-RING - ADAPTER
4610.2	O-RING - BEARING CARRIER
6521	PLUG - BEARING HOUSING VENT
6541	LOCKWASHER BEARING
6569	PLUG - BEARING HOUSING DRAIN - Not Shown
6570.12	SCREW - CLAMP
6570.2	SCREW - COVER/ADAPTER
6570.3	SCREW - BEARING CARRIER SET
6570.4	SCREW - FOOT
6570.5	SCREW - BEARING HOUSING
6572.1	STUD - CASING
6572.2	STUD - GLAND - Not Shown
6580.1	NUT - CASING
6580.2	NUT - GLAND - Not Shown
6700	KEY - SHAFT/COUPLING

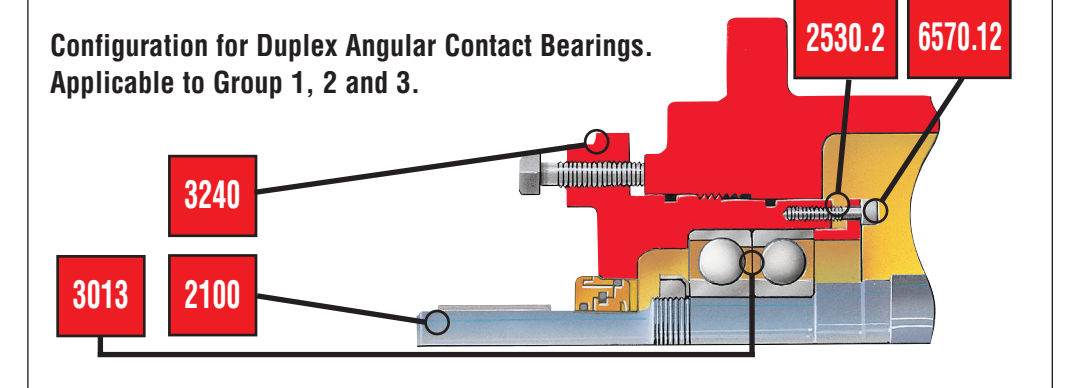

GROUP 1 (not to scale)

- 1½ x1LF-4
- 1½ x1-6
- 3x1½-6
- 3x2-6
- 1½ x1LF-8
- 1½ x1-8
- 3x1½-8

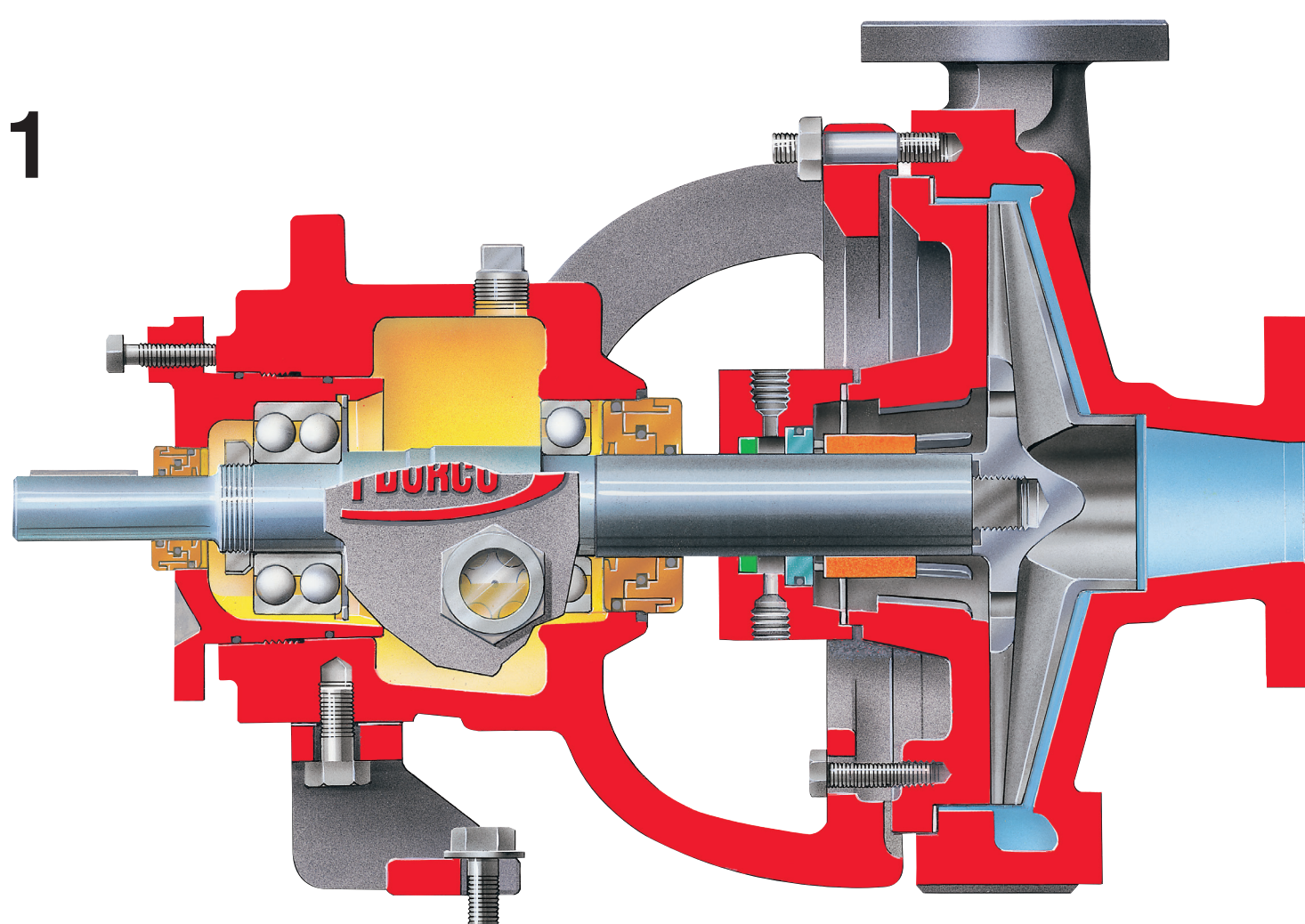

GROUP 3 (not to scale)

- 8x6-14A
 - 10x8-14
 - 6x4-16
 - 8x6-16A
 - 10x8-16
 - 10x8-16H
 - 10x8-17*
- *Max. speed 1450 RPM

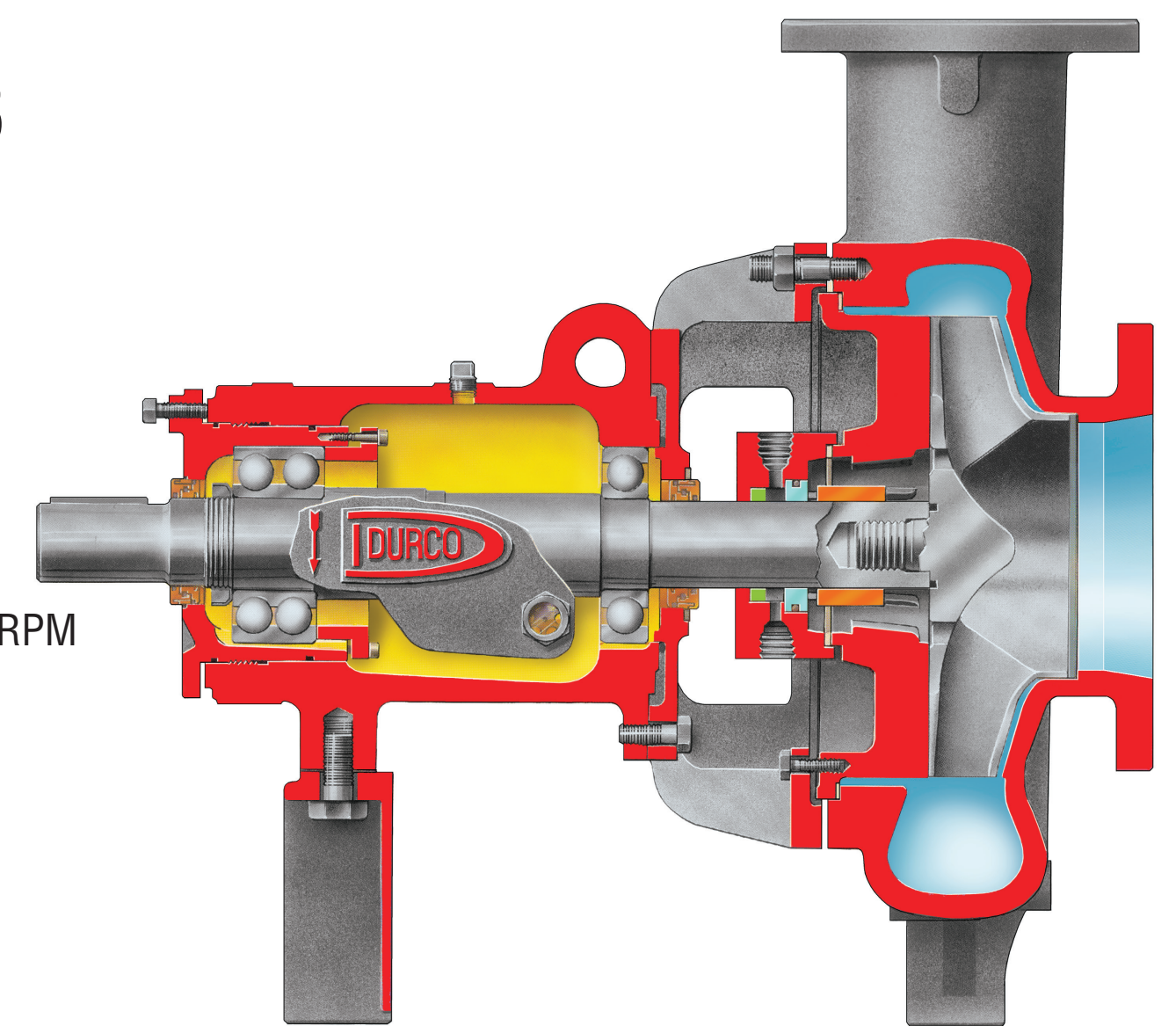

Building Blocks for Extended Reliability



Optional Front Vane Open Style Impeller

