

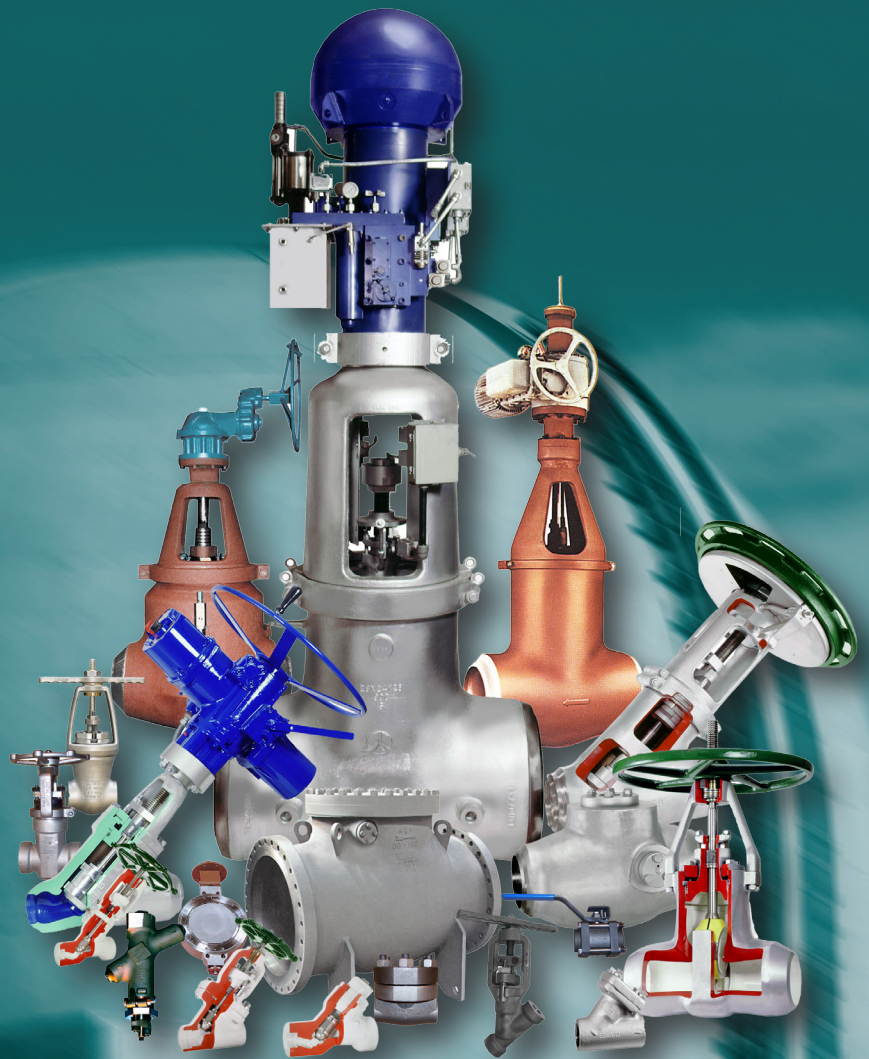

# *Edward and Anchor/Darling* Nuclear Application Valves



*Experience In Motion*



## *We'll Support You*

The Flowserve Flow Control Division is dedicated to providing continuous aftermarket support to our nuclear customers. Safety-related valves and parts are supplied in accordance with ASME Section III and 10 CFR 50 Appendix B on a routine basis; and more importantly, in support of refueling outages and forced outages at nuclear generating stations.

Flowserve engineers, with working knowledge of nuclear applications and requirements are available on a 24-hour basis to respond to phone calls from nuclear customers with critical outage and unforeseen forced outage help requirements. At Flowserve, *we understand the necessity of maintaining critical-path schedules!*

When you specify Flowserve nuclear safety-related valves, you can rest assured that the ongoing support and technical backup you may need down the road will be available to you *right now!*

Flowserve's Edward and Anchor/Darling valves are manufactured exclusively at our Raleigh, North Carolina, operation. Of the various Flowserve manufacturing facilities, the Flow Control Division's Raleigh operation is a long-time holder of ASME Section III N and NPT stamps.

We maintain a quality assurance system in accordance with ASME Section III and 10 CFR 50 Appendix B with controlled copies of our QA Manual available to nuclear customers. Non-destructive testing including radiography, liquid penetrant inspection, mag particle inspection, ultrasonic testing, PMI and mechanical property testing are performed in-house by ASNT/EN 473 qualified examiners and inspection personnel. Design reports, seismic reports, environmental qualification reports and certified drawings are prepared by Raleigh's engineering department. Additionally, Flowserve's Flow Control Division offers dedication of commercial-grade items by qualified inspection personnel based on engineering-prescribed critical characteristics and dedication methods.

***Specify Flowserve Edward and Anchor/Darling valves for nuclear safety-related requirements to ensure strict adherence to applicable nuclear codes and standards, on-time delivery and continuing aftermarket parts support.***

## Table of Contents

Edward Figure Number Index	5	Features and Description of Edward	
Edward Valves Availability Chart	6	Flite-Flow Globe Valves	74
Edward Description of Figure Number System	8	Special Application Valves	75
Anchor/Darling Figure Number Index	10		
Anchor/Darling Valves Availability Chart	11	<b>Anchor/Darling Globe Valves</b>	<b>89</b>
Anchor/Darling Description of Figure Number System	14	Features and Description of Anchor/Darling	
High Performance for Critical Service	16	800 Series Globe Valves	90
A History of Firsts	19	Parts Specification List for Anchor/Darling	
Edward and Anchor/Darling Valves Available for Nuclear Service	20	800 Series Globe Valves	91
Edward Forged and Cast Steel Valves for Nuclear Service	21	Features and Description of 1878 Series Globe Valve	94
Checklist of Customer Information Required		Parts Specification List for Anchor/Darling	
for Nuclear Valve Proposals	22	1878 Series Globe Valves	95
Flowserve Edward Stored Energy Actuator	22	Features and Description of Flowserve	
Gas-Hydraulic Actuators for Fail-Safe Isolation Valves	23	Anchor/Darling Globe Valves	100
Main Steam and Main Feedwater Isolation Valves	24	Custom-Designed Plugs	101
		Power-Actuated Globe Valves	101
<b>Edward Gate Valves</b>	<b>25</b>	Parts Specification List for Anchor/Darling	
Features and Description of Edward Equiwedge Gate Valves	26	Globe Valves	102
Parts Specification List for Edward Gate Valves	27		
Features and Description of Edward Equiwedge Gate Valves	28	<b>Edward Check Valves</b>	<b>109</b>
Center Cavity Overpressurization	28	Controlled Closure Check Valve	113
		Features and Description of Flowserve Edward Check Valves	114
<b>Anchor/Darling Gate Valves</b>	<b>35</b>	Features and Description of Flowserve Edward One-Piece	
Features and Description of Anchor/Darling		Tilting-Disc Check Valves	115
800 Series Gate Valves	36	Parts Specification List for Edward	
Parts Specification List for Anchor/Darling		One-Piece Tilting-Disc Check Valve	116
800 Series Gate Valves	37		
Features and Description of		<b>Anchor/Darling Check Valves</b>	<b>127</b>
1888 Series Double-Disc Gate Valves	39	Features and Description of 800 and 1878 Series	
Parts Specification List for Anchor/Darling		Piston Check Valves	129
1888 Series Double-Disc Gate Valves	40	Parts Specification List for Anchor/Darling 800 and	
Features and Description of Double-Disc Gate Valves	42	1878 Piston Check Valves	130
Parts Specification List for Double-Disc Gate Valves	43	Features and Description of 1878 Series Swing-Check Valves	134
Features and Description of Anchor/Darling		Parts Specification List for Anchor/Darling	
Flex-Wedge Gate Valves	49	1878 Swing-Check Valves	135
Parts Specification List for Anchor/Darling		Features and Description of Anchor/Darling	
Flex-Wedge Gate Valves	50	Check Valves	138
		Parts Specification List for Flowserve Anchor/Darling	
<b>Edward Globe and Stop-Check Valves</b>	<b>57</b>	Tilting-Disc Check Valves	140
Features and Description of Edward Bolted Bonnet		Parts Specification List for Flowserve Anchor/Darling	
Globe Valves	58	Swing Check Valves	141
Parts Specification List for Edward		Parts Specification List for Flowserve Anchor/Darling	
Bolted Bonnet Globe Valves	59	Lift Check Valve	142
Features and Description of Edward			
Univalve Globe Valves	62	<b>Anchor/Darling Ball Valves</b>	<b>153</b>
Parts Specification List for Edward Univalve Valves	63	Features and Description of Flowserve Anchor/Darling	
Features and Description of Edward		Ball Valves	154
Hermavalve Hermetically Sealed Valves	68	Parts Specification List for Anchor/Darling Ball Valves	155
Parts Specification List for Edward Hermavalve	70		
Features and Description of Edward Stop-Check Valves	72		
Parts Specification List for Edward Globe Valves,			
Stop-Check and Piston Lift Check	73		

## **Anchor/Darling Butterfly Valves** **175**

Features and Description of Flowserve Anchor/Darling Butterfly Valves	176
Approximate Weights by Valve Design	177
Standard Materials of Construction	177
Performance Characteristics	179

## **Special Applications Valve** **189**

Controlled Closure Check Valve	191
Excess Flow Check Valves	192
Vacuum Breaker Valves	194

## **Accessories/Actuators** **195**

Accessories	196
Accessories – Cast and Forged Steel	197
Actuators – Forged and Cast Steel	199
Required Information for Motor Actuators	200

## **Tables and Charts** **201**

Material Chemical Analysis (ASME or ASTM)	202
ASME B16.34 – 2009 Pressure/Temperature Ratings	203

## **Technical Information** **239**

1. Stop and Check Valve Applications Guide	241
1.1 Stop Valve Applications	241
1.1.1 Stop Valve Types and Typical Uses	241
1.1.2 Throttling Characteristics of Edward Stop Valves	242
1.1.3 Stop Valve Actuators and Accessories	243
1.1.4 By-Passes and Drains	244
1.1.5 Stop Valve Application Chart	245
1.2 Check Valve Applications Guide	246
1.2.1 Check Valve Types and Typical Uses	246
1.2.2 Check Valve Applications Chart	249
1.3 Check and Stop-Check Valve Installation Guidelines	250
1.3.1 Adjacent Flow Disturbances	252
1.3.2 Other Problem Sources	254
1.4 Check Valve Performance	254
1.4.1 Check Valve Seat Tightness	254
1.4.2 Pressure Surge and Waterhammer	255
1.4.3 Check Valve Accessories and Special Features	258
1.4.4 Check/Stop-Check Valve Periodic Inspection and Preventive Maintenance	258
2. Flow Performance	259
2.1 Choose the Best Valve Size for Your Service Conditions	259
2.1.1 Pressure Drop, Sizing and Flow Rate Calculations – Fully Open Valves – All Types	259
2.2 Basic Calculations	260
2.2.1 Pressure Drop	260
2.2.2 Required Flow Coefficient	260
2.2.3 Flow Rate	261

2.2.4 Inlet Flow Velocity	261
2.3 Corrections Required with Large Pressure Drops	261
2.3.1 Gas and Steam Flow	261
2.3.1.1 Pressure Drop	261
2.3.2 Liquid Flow – Cavitation and Flashing	262
2.4 Check Valve Sizing	263
2.4.1 Sizing Parameter	263
2.4.2 Calculations for Check Valves Less Than Fully Open	264
2.4.3 Sizing Guidelines	264
2.5 Pipe Reducer Coefficient	265
2.5.1 Pipe Geometry Factor	266
2.5.2 Other Coefficients	266
Conversion of Measurement Units	282
3. Flowserve Valve Design Standards and Features	283
3.1 Codes and Standards	283
3.2 Pressure Ratings	283
3.3 Pressure-Seal Construction	284
3.4 Hardfacing	285
3.5 Valve-Stem Packing	285

## **Maintenance**

Maintenance	286
-------------	-----

## **References to Related Brochures**

Brochure	Document Number
Flowserve - Edward	EVENCT0001
Flowserve - Edward	EVENCT0002
Flowserve - Edward and Anchor/Darling Valves	EVENCT0004

**In addition to the valves featured in this catalog, Flowserve's Flow Control Division also supplies the following valves for nuclear power plant service:**

- **Flowserve Valtek Control Valves and Pneumatic Actuators**
- **Flowserve BW/IP gate, globe and check valves**
- **Flowserve Durco ball, butterfly and plug valves**
- **Flowserve Worcester ball valves**
- **Flowserve McCanna ball valves**
- **Flowserve Contromatic ball and butterfly valves**
- **Flowserve Vogt gate globe and check valves**
- **Crispin air release and air vacuum valves**
- **DFT (Durabla) in-line check valves**
- **HBE automatic recirculation valves**
- **METREX HVAC control valves**

**For further information on these or any Flow Control Division valve or actuation products, contact your Flowserve sales engineer.**

Flowserve - Edward Figure Number Index

Table with 4 columns: Figure, Forged, Cast, Nuclear. It contains three sections of data, each with a red header row and multiple rows of valve specifications and figure numbers.

• These valves can be constructed for nuclear service.
Note: See "References to Related Brochures" chart in the Table of Contents to locate figures that do not appear in this brochure.



## Flowserve - Edward Valves Availability Chart

### Edward Forged Steel, Globe, Angle and Check Valves

Description	Pressure Rating <sup>1,2</sup>	Size <sup>2</sup>	Ends	Page
<b>Globe Stop Valves</b>	ASME 600(110)	¼(6) thru 2(50)	Threaded, Socket	58-60
<b>Univalve Globe Stop Valves</b>	ASME 1500(260)	½(15) thru 4(100)	Threaded, Socket, Butt Weld	62-64, 66
	ASME 2500(430)			
<b>Hermavalue Globe Stop Valves</b>	ASME to 1690(290)	½(15) thru 2-½(65)	Socket, Butt Weld	68-71
<b>Globe Stop-Check Valves</b>	ASME 600(110)	¼(6) thru 2(50)	Threaded, Socket	58-59, 61
<b>Univalve Globe Stop-Check Valves</b>	ASME 1500(260)	½(15) thru 4(100)	Threaded, Socket, Butt Weld	62-63, 65, 67
	ASME 2500(430)			
<b>Piston Check Valves</b>	ASME 600(110)	¼(6) thru 2(50)	Threaded, Socket	110
<b>Univalve Piston Check Valves</b>	ASME 1500(260)	½(15) thru 4(100)	Socket, Butt Weld	111-112
	ASME 2500(430)			
<b>Ball Check Valves</b>	ASME 600(110)	¼(6) thru 2(50)	Threaded, Socket	110

1. See paragraph 3.2, page 283 for definition of various pressure ratings available.

2. Metric equivalent values for ratings and sizes are in parentheses.

3. Refer to pages 203 through 238 for the applicable pressure ratings.

## Flowserve - Edward Valves Availability Chart

### Edward Cast Steel Gate, Globe, Angle and Check Valves

Description	Pressure Rating <sup>1,2</sup>	Size <sup>2</sup>	Ends	Page
<b>Bolted Bonnet Globe and Angle Valves, Stop and Stop-Check (Non-Return) and Bolted Cover Piston Check</b>	ASME 600(110)	2-½(65) thru 14(350)	Butt Weld or Flanged	72, 76, 78, 114, 117
<b>Pressure Seal Bonnet Globe and Angle Valves Stop and Stop-Check (Non-Return)</b>	ASME 600(110)	2-½(65) thru 14(350)	Butt Weld or Flanged	72, 76, 78
	ASME 900(150)	3(80) thru 14(350)		72, 80, 82, 119, 120
	ASME 1500(260)	2-½(65) thru 14(350)		72, 84, 86, 122, 123
<b>Pressure Seal Cover, Piston Check Valves</b>	ASME 900(150)	3(80) thru 14(350)	Butt Weld or Flanged	114, 119
	ASME 1500(260)	2-½(65) thru 24(600)		72, 122, 123
<b>Equiwedge® Gate Valves</b>	ASME 600(110) & 900(150)	2-½(65) thru 32(800)	Butt Weld or Flanged	26-32
	ASME 1500(260)	2-½(65) thru 24(600)		26-28, 33-34
<b>Flite-Flow® Globe Valves, Stop and Stop-Check (Non-Return)</b>	ASME 600(110)	3(80) thru 32(800)	Butt Weld or Flanged	72-74, 77, 79
	ASME 900(150)	3(80) thru 16(400)		72-74, 81, 83
	ASME 1500(260)	3(80) thru 24(600)		72-74, 85, 87
<b>Flite-Flow® Piston Check Valves</b>	ASME 600(110)	3(80) thru 32(800)	Butt Weld or Flanged	114, 117, 118
	ASME 900(150)	3(80) thru 16(400)		114, 119, 120
	ASME 1500(260)	3(80) thru 24(600)		114, 122, 124
<b>Tilting-Disc Check Valves</b>	ASME 600(110)	6(150) thru 20(500)	Butt Weld	115, 118
	ASME 900(150) & 1500(260)	2½(65) thru 24(600)		115, 121, 125

1. See paragraph 3.2, page 283 for definition of various pressure ratings available.

2. Metric equivalent values for ratings and sizes are in parentheses.

3. Refer to pages 203 through 238 for the applicable pressure ratings.

## Edward Description of Figure Number System

### Special Material Suffixes

<b>CF8C</b>	Cast 18-8 stainless steel (type 347) body and bonnet. Parts in contact with line fluid either cast or forged 18-8 stainless steel or equivalent.
<b>CF3M</b>	Cast 18-8 stainless steel (type 316L) body and bonnet. Parts in contact with line fluid either cast or forged 18-8 stainless steel or equivalent.
<b>CF8M</b>	Cast 18-8 stainless steel (type 316) body and bonnet. Parts in contact with line fluid either cast or forged 18-8 stainless steel or equivalent.
<b>C5</b>	Cast chromium molybdenum (5 chromium ½ molybdenum) Grade C5 alloy steel body and bonnet. Trim of equal or higher grade alloy steel.
<b>F11</b>	Body and bonnet of forged chromium molybdenum (1-¼ chromium, ½ molybdenum) Grade F11 alloy steel.
<b>F22</b>	Body and bonnet of forged chromium molybdenum (2-¼ chromium, 1 molybdenum) Grade F22 alloy steel.
<b>F91</b>	Body and bonnet of forged chromium molybdenum (9 chromium, 1 molybdenum) Grade F91 alloy steel.
<b>F316</b>	Body and bonnet of forged Type 316 stainless steel.
<b>F316L</b>	Body and bonnet of forged Type 316L stainless steel.
<b>F347</b>	Body and bonnet of forged Type 347 stainless steel.
<b>F347H</b>	Body and bonnet of forged Type 347H stainless steel.
<b>LF2</b>	Forged carbon steel material on which Charpy impact tests have been performed on forging heat to determine low-temperature properties.
<b>WC1</b>	Cast carbon molybdenum Grade WC1 body and bonnet.
<b>WC6</b>	Cast chromium molybdenum (1-¼ chromium, ½ molybdenum) Grade WC6 alloy steel body and bonnet.
<b>WC9</b>	Cast chromium molybdenum (2-¼ chromium, 1 molybdenum) Grade WC9 alloy steel body and bonnet.
<b>WCB</b>	Cast carbon steel Grade WCB body and bonnet.
<b>WCC</b>	Cast carbon steel Grade WCC body and bonnet.
<b>C12A</b>	Cast chromium molybdenum (9 chromium, 1 molybdenum) alloy steel body and bonnet.

### Special Feature Suffixes

<b>A</b>	Special body only — body pattern alterations not required. Flanges on forged valves not normally supplied with flanges. On socket end forged steel valves the inlet and outlet ends are different.
<b>B</b>	Venturi pattern body.
<b>C</b>	Locking devices consisting of padlock and chain.
<b>CD</b>	Locking devices, indicator type.
<b>DD</b>	Equalizer external.
<b>DDI</b>	Equalizer internal.
<b>E</b>	Permanent drain, hole in disc or groove in disc face.
<b>F</b>	Special trim material: used to designate special disc material, special stem material, or inconel spring in check valves.
<b>FF</b>	Special yoke bushing material, such as Austenitic Nodular Iron.
<b>G</b>	Bypasses on all types of cast steel valves
<b>H</b>	Spur gear operation.
<b>HH</b>	Bevel gear operation.
<b>HHL</b>	Valve-less bevel gear actuator but with actuator mounting equipment.
<b>J</b>	Any unclassified special.
<b>K</b>	Throttle disc or skirted disc.
<b>L</b>	Impactor operated. Used now only to indicate impactor handwheel or handle on valves not regularly furnished with impactor.
<b>LD</b>	Impactorgear or Impactodrive.
<b>M</b>	Motor actuated.
<b>ML</b>	Valve-less actuator but with motor actuator mounting equipment.

<b>MM</b>	Cylinder/diaphragm actuated. Either hydraulic or pneumatic.
<b>MML</b>	Valve-less cylinder/diaphragm actuator but with actuator mounting equipment.
<b>N</b>	Body drilled and tapped or socketed for drains, with or without nipple, with or without drain valves.
<b>P</b>	Non-standard packing of all types.
<b>PL</b>	Plastic lined.
<b>Q</b>	Non-standard bonnet gaskets or gasket plating.
<b>R</b>	Special lapping and honing and gas testing (recommended for valves on high pressure gas service).
<b>S</b>	Smooth finish on contact faces of end flanges.
<b>T</b>	Critical service requiring special testing and/or NDE.
<b>UF</b>	Unfinished ends.
<b>W</b>	Stellited seat and disc. Suffix not used for valves that are cataloged as having stellited seat and disc as standard.
<b>X</b>	Ring joint facing on body end flanges.
<b>Y</b>	Welding ends either socket or butt. Suffix not used for valves where figure number designates welding ends as standard, such as Fig. 36224 and 66228, for example.
<b>T1</b>	ASME Section III Class 1 compliance.
<b>T2</b>	ASME Section III Class 2 compliance.
<b>T3</b>	ASME Section III Class 3 compliance.
<b>T4</b>	ASME Section III compliance without "N" stamp.
<b>T5</b>	Nuclear safety related-10CFR21 invoked.



## Edward Description of Figure Number System

### Example

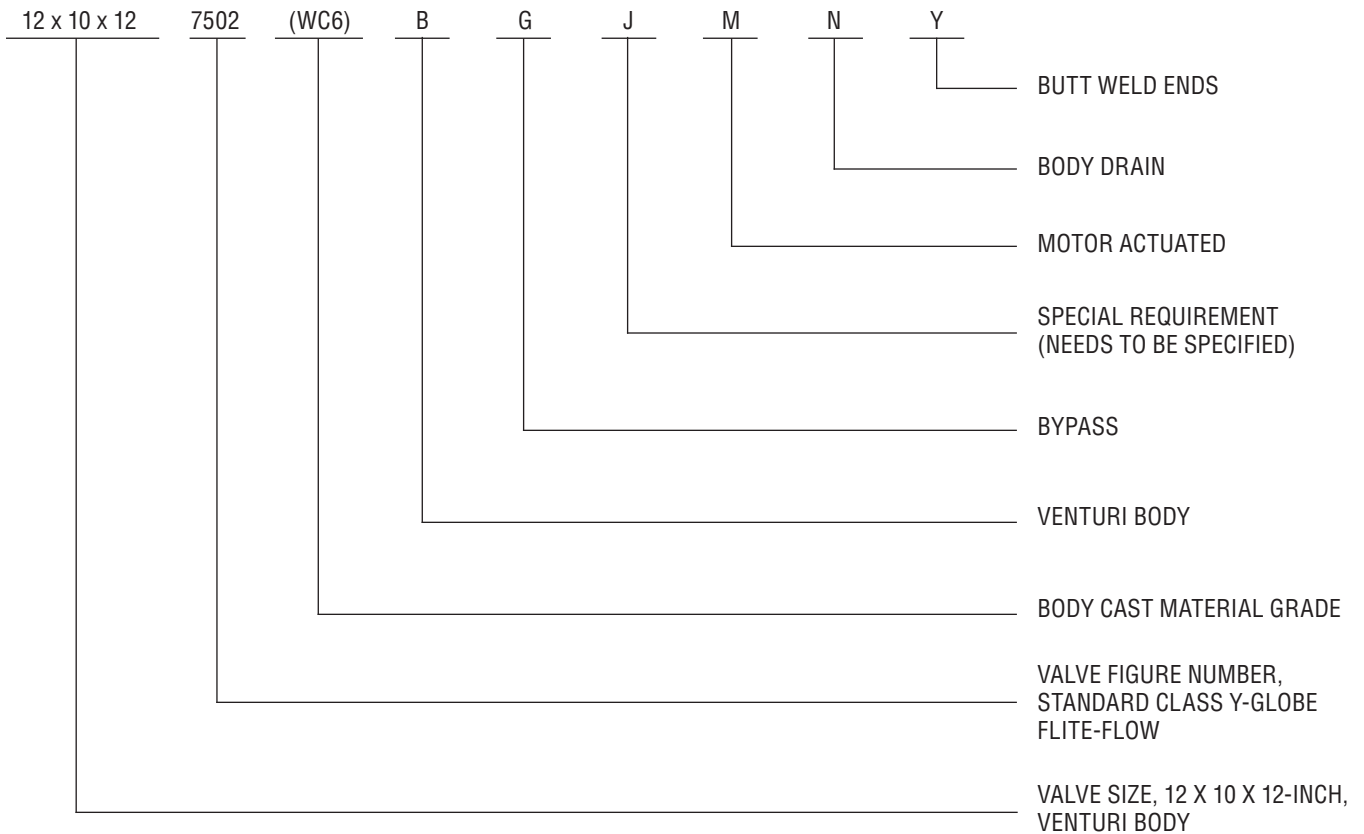

### XX

1 alpha digit prefix Indicates design revision, if applicable.  
2 alpha digits indicates style of pressure combo valve.

### XXXXX

3-5 digits figure number

### (XXX)

3-4 digits body material designation

### XXXXXXX

1 or more digits as required suffixes (see list)

*Unless otherwise specified when ordering Edward valves, the standard material of construction for Forged products is A/SA105 Carbon Steel, and for Cast products is SA216 Grade WCB Carbon Steel.*

Listed on page 8 are the letter suffixes used to indicate variations from standard construction, or special features (Ex. 618K, 7506 [WC6]Y, and 847 AH.)

When two or more suffixes follow a figure number, a definite suffix sequence is to be used.

The sequence is:

- 1) Special material (if applicable).
- 2) Other applicable feature suffixes in alphabetical order, except T1-T5, which are listed last.



## Flowserve - Anchor/Darling Figure Number Index

Figure	Nuclear
BAG41C	103
BAG41U	103
BBF89L	185
BBF89V	180,181
BBV93U	157
BBV94C	161
BBV94S	159
BBV94U	160
BBV95C	164
BBV95S	162
BBV95U	163
BBV96U	157
BDD10C	44
BDD10U	44
BGB21C	103
BGB21U	103
BGT01C	51
BGT01U	51
BSC52C	148
BSC52U	148
BTD63C	143
BTD63U	143
BYA80C	103
BYA80Y	103
BYG31C	103
BYG31U	103
CAG41C	104
CAG41U	104
CBF89V	182
CBL91L	186
CBV93U	158
CBV94C	167
CBV94S	165
CBV94U	166

Figure	Nuclear
CBV95C	170
CBV95S	168
CBV95U	169
CBV96U	158
CDD10C	45
CDD10U	45
CGB21C	104
CGB21U	104
CGT01C	52
CGT01U	52
CSC51C	149
CSC51U	149
CTD63C	144
CTD63U	144
CYA80C	104
CYA80U	104
CYG31C	104
CYG31U	104
EAG41C	105
EAG41U	105
EAG44C	105
EAG44U	105
EBF89L	187,188
EBF89V	183,184
EBV94C	172
EBV94S	171
EBV95C	174
EBV95S	173
EDD10C	46
EDD10U	46
EDD15C	46
EDD15U	46
EGB21C	105
EGB21U	105

Figure	Nuclear
EGB24C	105
EGB24U	105
EGT01C	53
EGT01U	53
EGT05C	53
EGT05U	53
ESC51C	150
ESC51U	150
ESC58C	150
ESC58U	150
ETD63C	145
ETD63U	145
ETD67C	145
ETD67U	145
EYA80C	105
EYA80U	105
EYA81C	105
EYA81U	105
EYG31C	105
EYG31U	105
EYG34C	105
EYG34U	105
FAG44U	106
FDD15C	47
FDD15U	47
FGB24U	106
FGT05C	54
FGT05U	54
FSC58C	151
FSC58U	151
FTD67C	146
FTD67U	146
FYA81U	106
FYG34U	106

Figure	Nuclear
GAG44U	107
GDD15C	48
GDD15U	48
GGB24U	107
GGT05C	55
GGT05U	55
GSC58C	152
GSC58U	152
GTD67C	147
GTD67U	147
GYA81U	107
GYG34U	107
NBG34S	98
NBG34U	98
NGB24S	96
NGB24U	96
NGI29S	99
NGI29U	99
NPC78S	133
NPC78U	133
NSC51S	136
NSC51U	136
NSC58S	137
NSC58U	137
NYG34S	97
NYG34U	97
NYP79S	132
NYP79U	132
TDD15S	41
TDD15U	41
UGB24S	92
UGB24U	92
USW90S	38
USW90U	38

These valves can be constructed for nuclear service.

Note: See "References to Related Brochures" chart in the Table of Contents to locate figures that do not appear in this brochure.

## Flowserve - Anchor/Darling Valves Availability Chart

### Anchor/Darling Small Bore, Globe, Gate and Check Valves

Description	Pressure Rating <sup>1,2</sup>	Size <sup>2</sup>	Ends	Page
Globe Stop Valves	ASME 800(130)	½(15) thru 2(50)	Socket, Butt Weld	89-92
	ASME 1878(310)	½(15) thru 2(50)	Socket, Butt Weld	94-97
Gate Stop Valves	ASME 800(130)	½(15) thru 2(50)	Socket, Butt Weld	36-38
	ASME 1888(310)		Socket, Butt Weld	39-41
Bellows Globe Stop Valves	ASME to 800	½(15) thru 2(50)	Socket, Butt Weld	93
	ASME to 1878(310)	½(15) thru 2(50)	Socket, Butt Weld	98, 99
Piston Check Valves	ASME 800	½(15) thru 2(50)	Socket, Butt Weld	129 - 131
	ASME 1878(310)	½(15) thru 2(50)	Socket, Butt Weld	129, 130, 132, 133
Swing Check Valves	ASME 1878 (310)	½(15) thru 2(50)	Socket, Butt Weld	134-137

1. See paragraph 3.2, page 283 for definition of various pressure ratings available.

2. Metric equivalent values for ratings and sizes are in parentheses.

3. Refer to pages 203 through 238 for the applicable pressure ratings.



## Flowserve - Anchor/Darling Valves Availability Chart

### Anchor/Darling Cast Steel Gate, Globe, Angle and Check Valves

Description	Pressure Rating <sup>1,2</sup>	Size <sup>2</sup>	Ends	Page
<b>Bolted Bonnet Globe and Angle Stop Valves</b>	ASME 150(25)	2-½(65) thru 24(600)	Butt Weld or Flanged	100-103
	ASME 300(50)	2-½(65) thru 24(600)		100-102, 104
	ASME 600(110)*	2-½(65) thru 24(600)		100-102, 105
<b>Pressure Seal Bonnet Globe and Angle Stop Valves</b>	ASME 600(110)	2-½(65) thru 24(600)	Butt Weld or Flanged	100-102, 105
	ASME 900(150)	2-½(65) thru 24(600)		100-102, 106
	ASME 1500(260)	2-½(65) thru 24(600)		100-102, 107
<b>Bolted Bonnet Double-Disc Gate Valves</b>	ASME 150(25)	2-½(65) thru 24(600)	Butt Weld or Flanged	42-44
	ASME 300(50)			42, 43, 45
	ASME 600(110)			42, 43, 46
<b>Pressure Seal Bonnet Double-Disc Gate Valves</b>	ASME 600(110)	2-½(65) thru 24(600)	Butt Weld or Flanged	42, 43, 46
	ASME 900(150)			42, 43, 47
	ASME 1500(260)			42, 43, 48

1. See paragraph 3.2, page 283 for definition of various pressure ratings available.
2. Metric equivalent values for ratings and sizes are in parentheses.
3. Refer to pages 203 through 238 for the applicable pressure ratings.

## Flowserve - Anchor/Darling Valves Availability Chart

### Anchor/Darling Cast Steel Gate, Globe, Angle and Check Valves

These valves can be constructed and supplied for nuclear service.

Description	Pressure Rating <sup>1,2</sup>	Size <sup>2</sup>	Ends	Page
<b>Bolted Bonnet Flex Wedge Gate Valves</b>	ASME 150(25)	2-½(65) thru 24(600)	Butt Weld or Flanged	49-51
	ASME 300(50)			49, 50, 52
	ASME 600(110)			49, 50, 53
<b>Pressure-Seal Bonnet Flex Wedge Gate Valves</b>	ASME 600(110)	2-½(65) thru 24(600)	Butt Weld or Flanged	49, 50, 53
	ASME 900(150)			49, 50, 54
	ASME 1500(260)			49, 50, 55
<b>Bolted Bonnet Tilting Disc Check Valves</b>	ASME 150(25)	2-½(65) thru 24(600)	Butt Weld or Flanged	138-140, 143
	ASME 300(50)			138-140, 144
	ASME 600(110)			138-140, 145
<b>Pressure-Seal Bonnet Tilting Disc Check Valves</b>	ASME 600(110)	2-½(65) thru 24(600)	Butt Weld or Flanged	138-140, 145
	ASME 900(150)			138-140, 146
	ASME 1500(260)			138-140, 147
<b>Bolted Bonnet Swing Check Valve</b>	ASME 150(25)	2-½(65) thru 24(600)	Butt Weld or Flanged	138, 139, 141, 148
	ASME 300(50)			138, 139, 141, 149
	ASME 600(110)			138, 139, 141, 150
<b>Pressure Seal Bonnet Swing Check Valve</b>	ASME 600(110)	2-½(65) thru 24(600)	Butt Weld or Flanged	138, 139, 141, 150
	ASME 900(150)			138, 139, 141, 151
	ASME 1500(260)			138, 139, 141, 152

1. See paragraph 3.2, page 283 for definition of various pressure ratings available.

2. Metric equivalent values for ratings and sizes are in parentheses.

3. Refer to pages 203 through 238 for the applicable pressure ratings.



## Anchor/Darling Description of Figure Number System

### Description

1	Flex Wedge	Bolted Bonnet Round New Std	51	Swing Check	Bolted Bonnet Std (80%) No Penetration
2	Flex Wedge	Bolted Bonnet Rectang Old Std	52	Swing Check	Bolted Bonnet Std with Penetration
3	Flex Wedge	Bolted Bonnet Round w/Lip Seal	53	Swing Check	Bolt Bonnet Old (100%) Type
4	Flex Wedge	Bolted Bonnet / Venturi Ports	54	Swing Check	Bolted Bonnet Std with Seal Weld
5	Flex Wedge	Pressure Seal Std	55	Swing Check	Bolt Bonnet (80%) Exercisable
6	Flex Wedge	Pressure Seal w/ Venturi Ports	56	Swing Check	Special
7	Flex Wedge	Pressure Seal with seal Weld	57	Swing Check	Press. Seal (Y-Type Body)
8	Flex Wedge	Special Body/Bonnet	58	Swing Check	Pressure Seal Std
10	DD Gate	Bolt Bonnet DD Std	59	Swing Check	Pressure Seal Exercisable
11	DD Gate	Bolted Bonnet DD with lip Seal	62	Tilting Disc Check	Bolt Bonnet (Seal Weld)
13	DD Gate	Bolt Bonnet Double Disc w/ Oval Flanges (150# or less)	63	Tilting Disc Check	Bolt Bonnet Std
14	DD Gate	Press. Seal DD with Venturi Ports	64	Tilting Disc Check	Special
15	DD Gate	Press. Seal Double Disc Std	65	Tilting Disc Check	Bolt Bonnet Exercisable
16	DD Gate	Bolt Bonnet Double disc - NRS	66	Tilting Disc Check	Press. Seal w/ Seal Weld
17	DD Gate	Bolted Bonnet - Non-Std.	67	Tilting Disc Check	Pressure Seal Std
18	DD Gate	Press. Seal Double Disc - Non Std.	68	Tilting Disc Check	Pressure Seal
19	DD Gate	Threaded Bonnet	69	Tilting Disc Check	Pressure Seal Exercisable
21	Globe	Bolted Bonnet (Straight) Stop	75	Lift Check Globe	Ball Check
22	Globe	Bolt Bonnet (Straight) Stop Check	76	Lift Check Globe	Bolt Bonnet - Horizontal
23	Globe	Bolt Bonnet with Seal Weld	77	Lift Check Globe	Bolt Bonnet - Angle
24	Globe	Press. Seal (Straight) Stop	78	Lift Check Globe	Pressure Seal - Horizontal
25	Globe	Press. Seal (Straight) Stop-Check	79	Lift Check Globe	Pressure Seal - Angle
26	Globe	Special (Piston Check 2" and smaller)	80	Other Products	Y Angle Bolted Bonnet
27	Globe	Pressure Seal (Throttle Service)	81	Other Products	Y Angle Pressure Seal
28	Globe	Bolted Bonnet (Throttle Service)	82	Other Products	Flow Regulating Valve (Metrex)
29	Globe	Instrument	83	Other Products	Dump Valve
31	Y-Globe	Bolted Bonnet Stop	84	Other Products	Flapper Gate Valve
32	Y-Globe	Bolt Bonnet Stop Check	85	Other Products	Chemical Connectors
33	Y-Globe	Bolt Bonnet with Seal Weld	86	Other Products	Slab Gate Valve
34	Y-Globe	Press. Seal Stop	87	Other Products	Isolation Device
35	Y-Globe	Press. Seal Stop-Check	88	Other Products	Hollow Cone Valve
36	Y-Globe	Pressure Seal (Throttle Service)	89	Other Products	Butterfly Valve - Wafer Type
37	Y-Globe	Pressure Seal (Venturi Ends)	90	Other Products	Split Wedge Gate Valve
38	Y-Globe	Piston Check (2" and Smaller)	91	Other Products	Butterfly Valve - Lugged Type
39	Y-Globe	Special	92	Other Products	Manifold Valve
41	Angle Globe	Bolted Bonnet Stop	93	Other Products	Recirculating Valve
42	Angle Globe	Bolt Bonnet Stop Check	94	Other Products	Ball Valve Standard Port
44	Angle Globe	Press. Seal Stop	95	Other Products	Ball Valve Full Port
45	Angle Globe	Press. Seal Stop-Check	96	Other Products	Ball Valve Top Entry
46	Angle Globe	Special	97	Other Products	Inline Check - GLC
			98	Other Products	Inline Check - WLC
			99	Other Products	Any Non-Standard Valve

### Valve Type

AC	Angle Globe Control	HC	Hollow Cone
AG	Angle Globe	ID	Isolation Device
AR	Air Relief/Surge Check	LJ	Larner Johnson
BC	Ball Check	MV	Manifold Valve
BF	Butterfly	NR	Non Return
BG	Bellows Globe	PC	Piston Check
BV	Ball Valve	PL	Dump
CC	Chemical Connector	PS	Parallel Slide
DC	Durabala Silent Check	PV	Plug Valve
DD	Double-Disc	RC	Recirculating Valve
DR	Drainer	SC	Swing Check
DV	Double Disc Venturi	SG	Slab Gate
FG	Flapper Gate	SV	Strainer Valve
FR	Flow Regulating	SW	Split Wedge
GB	Globe including Stop check and Lift Check	TD	Tilting-Disc Check
GC	Globe Control	YA	Y Angle
GI	Globe Instrument	YC	Y Globe Control
GT	Flex Wedge	YG	Y Globe
GV	Globe - Venturi	YP	Y Piston Check
		YV	Y Globe Venturi

### Features

A	Standard First Variation - Bonnet - Double Packing
	Tilt Disc - Horizontal Installation
	FW Body - Cast in Disc Guides
B	Non-Standard Second Variation - Bonnet - Single Packing
	Tilt Disc - Vertical Installation
	FW Body - Welded in Disc Guides
C	Body - Flanged Ends
D	Third Design Variation
E	Special End to End
F	Special Port Core
G	Body - One End Flanged
L	Lugged Ends
N	Bypass and Vent Bosses
S	Socket Weld or Special Ends
T	Brazed Seats or Reduced Ports
U	Butt-Weld Ends
V	Wafer Ends

### Pressure and Temperature Rating Class

A	<150
B	150
C	300
D	400
E	600
F	900
G	1500
H	2500
J	4500
K	1700
L	2700
M	3700
N	1878
S	Special
T	1888
U	800

**Example**

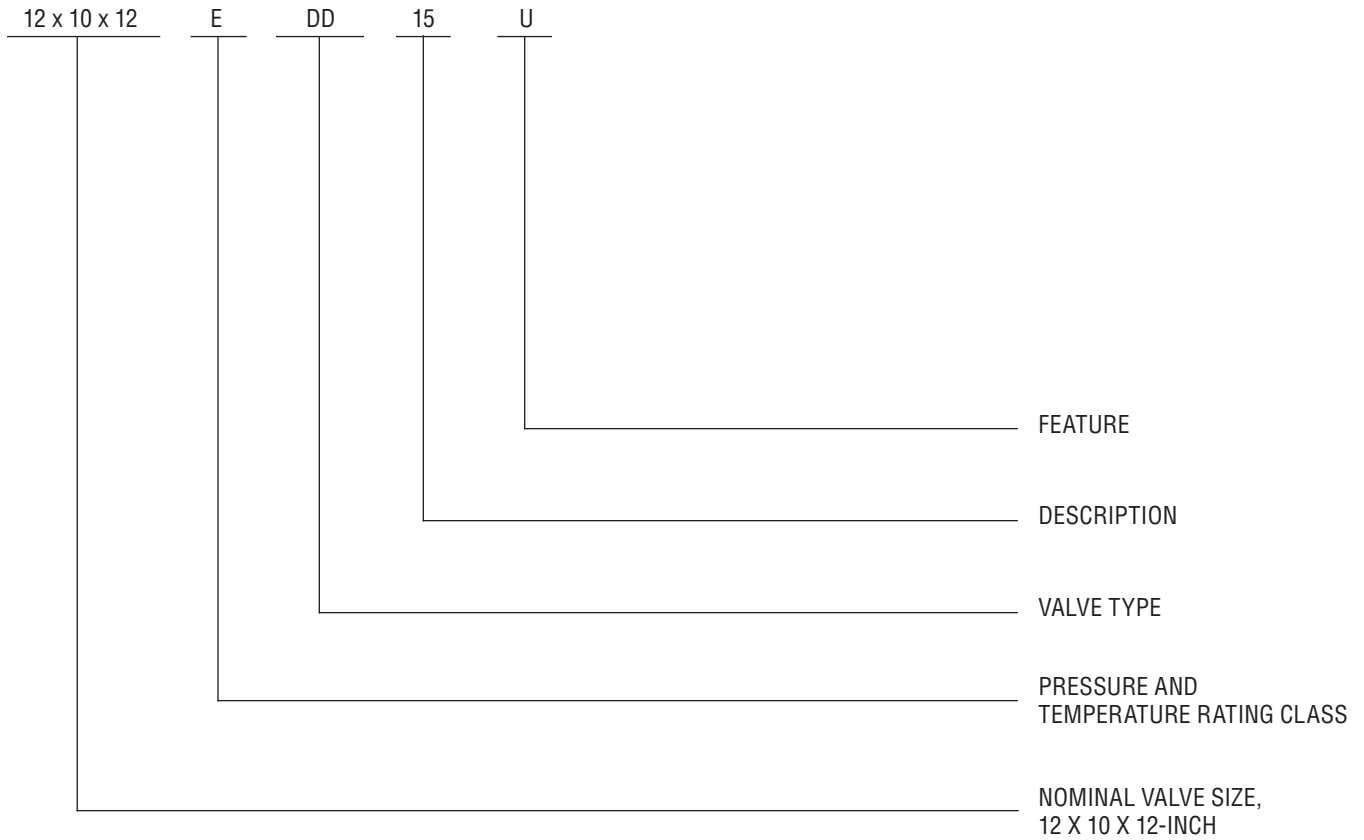

*Unless otherwise specified when ordering Anchor/Darling valves, the standard material of construction for Small Bore products and for Cast products is A/SA216 Grade WCB Carbon Steel.*

Custom and specialty materials, configurations and designs are available with Anchor/Darling products.



## High Performance for Critical Service

*Nuclear Safety Related ...* in this critical service, you can take no chances with safety, and you can accept no compromise in quality. Flowserve's Edward and Anchor/Darling valves don't just meet standards – *they exceed them*. Our dedication to engineered quality and rigorous design standards are demonstrated by understanding and appreciating of the *absolute necessity of dependability* for valves installed in nuclear reactors.

### Conservative Design

Flowserve's approach to the design of safety-related valves for nuclear service is highly conservative. We meet applicable codes and standards, but go beyond those criteria employing finite element stress analysis of critical valve areas coupled with stringent proof testing. This testing and real-world installed experience have resulted in valves that exhibit very high flow efficiencies.

You will find innovative design advantages throughout the Edward and Anchor/Darling Product Lines. For example, the Edward Equiwedge gate valve features a split-wedge gate assembly that aligns perfectly into the valve's seats by virtue of cast body guide grooves; this split-wedge feature ensures leak-tight closure even if a seismic event causes racking or distortion of piping. Many of what are today termed *industry standards* started out as design concepts on Flowserve drawing boards.

### Precision Manufacturing

Flowserve's Raleigh operation employs state-of-the-art six-axis machining centers that are computer controlled to

ensure *repeatability, parts interchangeability and spot-on perfect dependability*. Flowserve Raleigh has also developed reliable sources for castings, steel and other components that ensure continuous uninterrupted manufacturing cycles on time, within critical path shipment, of your nuclear valves and parts. Our suppliers are dedicated professionals who team with Flowserve to ensure your critical deliveries are "on the dock" on time and correct *every time*.

### Dedicated People

Flowserve's Raleigh operation employs highly skilled people dedicated to delivering the very finest and safest nuclear valves you can buy. Our engineering department is staffed with experienced senior men and women with years of practical experience working with nuclear safety-related applications in Raleigh and in the field; they bring *working knowledge of the nuclear power business* to your valve applications. These engineers mentor newer members of our engineering team, passing along insight and practical knowledge. Similarly, our inside sales and contract administration people bring years of practical hands-on experience to your valve requirements. They *speak the language* of nuclear application and will understand the intricacies of your technical inquiries.

***For nuclear power plant applications, call the professionals at Flowserve's Flow Control Division – Raleigh.***





### *Designed with an Eye on Your Bottom Line*

In-house computer-aided design and finite-element method capabilities give our engineering staff powerful tools to develop reliable valves for critical service applications. CAD-generated graphic models undergo FEM analysis to determine that stresses are within acceptable limits. Dynamic simulation of valve operation also helps ensure reliability of Flowserve Edward and Anchor/Darling valve performance.

Prototyping is just as important, and rigorous proof testing is a mainstay of Edward valve design. Before we approve a valve for production, we put it through hundreds, even thousands, of cycles to demonstrate that performance and sealing integrity will be maintained in service. Transducers relay data from test assemblies to computers for further analysis.

Laboratory simulation of critical services includes a steam generator and superheater, designed for 2700 psi and 1050°F. This flexible system allows testing of prototype valves under both low-pressure and high-pressure conditions. In addition to prototype testing, this system has been used for applications such as friction and wear tests of valve trim materials in hot water and steam environments; qualification tests of new or redesigned valves; and proof testing of new valve gaskets and valve stem packings.

Before we make the first production unit, that valve has already been through a rigorous program to ensure long life, simple maintenance and dependable performance for the lowest cost over the life of the valve. Again, people play important roles in design. The Flowserve product engineering department pools well over 400 years of valve experience.

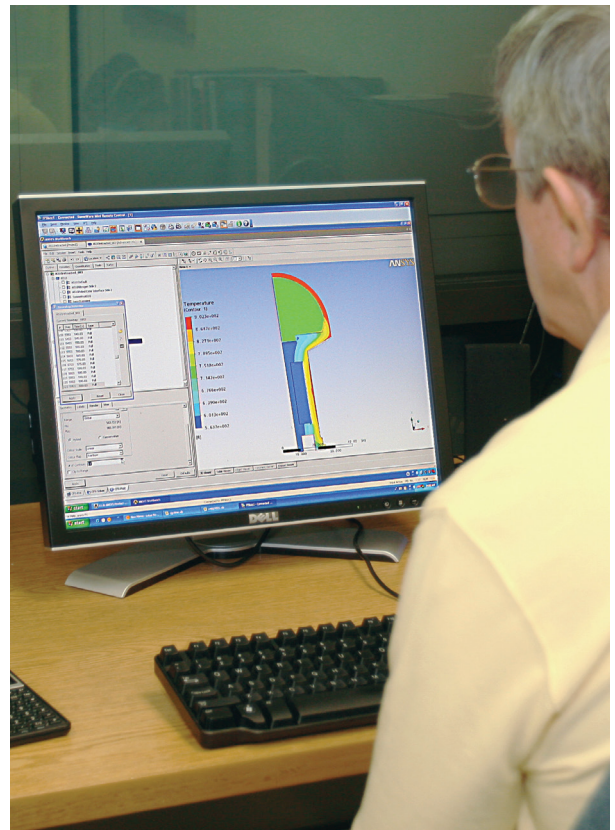



### Testing Beyond Code Requirements

At Flowserve Edward and Anchor/Darling Valves, quality assurance starts with meeting code requirements. Valves are manufactured to ASME section III and ANSI B16.34 (Standard, Limited and Special Classes), including standards for:

- Minimum wall thickness of valve body.
- Body, bonnet and body-bonnet bolting to specified ASME and ASTM material standards.
- Non-destructive examination requirements.
- Hydrostatic shell testing at 1.5 times the 100°F rating of the valve.

From there, Flowserve Edward and Anchor/Darling valves go on to exceed the code, with higher test standards and an additional battery of tests performed on every type of valve we make, using in-house test facilities and personnel to ensure expert quality control. Flowserve's quality assurance program includes:

#### Non-Destructive Examination

- NDE personnel are qualified in accordance with ASNT-TC-1A and EN473 requirements.
- castings are visually examined per MSS SP-55.
- The first five body castings from every pattern are 100 percent radiographed to verify casting quality.

#### Hydrostatic Testing

- The seat-leakage criteria—no visible leakage for forged steel stop, stop-check and check valves and 2ml/hour/inch of nominal valve size for cast steel—are stricter than the allowed leakage rate of MSS SP-61, which is 10ml/hour/inch of nominal valve size for stop valves and 40ml/nr/in for stop-check and check valves.
- Seat-leakage test is performed at 110 percent of 100°F rating.

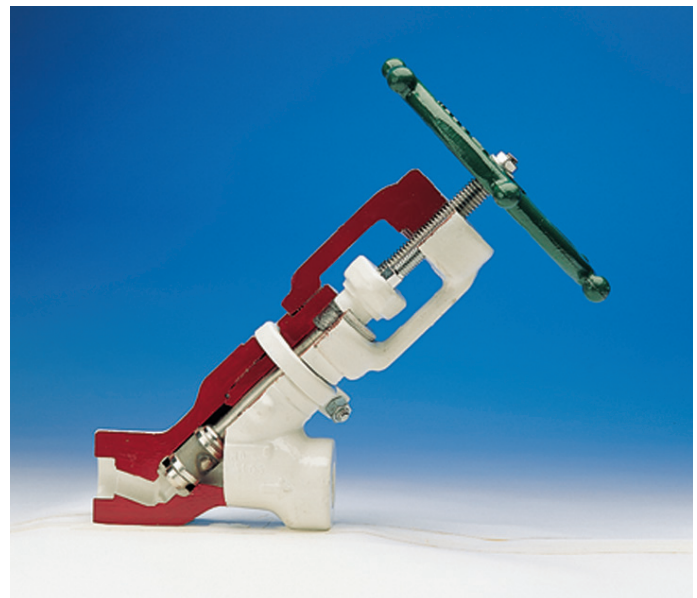

#### Quality Control

Requirements are clearly stated and measurements are taken to determine conformance to those requirements. "Quality" equals conformance to requirements.

#### Welding

Personnel and procedures are qualified in accordance with ASME Boiler and Pressure Vessel Code, Section IX and ASME Section III.

#### Additional Standard Tests for Specific Valves

Includes heavy-wall examination on large body castings.

We have listed only a few of the Flowserve Edward and Anchor/Darling valve standard tests that exceed industry requirements. In addition, Flowserve has the facilities and the expertise to meet additional quality assurance standards as required for the application.



## A History of Firsts

Feature	Benefit
Body-guided discs on globe and angle valves	Minimize wear and ensure alignment for tight sealing.
Integral Stellite hardfaced seats in globe and angle valves	Permit compact design and resist erosion.
Hermetically sealed globe valves with seal-welded diaphragms	Prevent stem leakage in critical nuclear plant applications.
Equalizers for large check and stop-check valves	Ensure full lift at moderate flow rates and prevent damage due to instability.
Compact pressure-seal bonnet joints	Eliminate massive bolted flanges on large, high-pressure valves.
Qualified stored-energy actuators	Allow quick-closing valves in safety-related nuclear plant applications.
Qualified valve-actuator combinations	Used in main steam and feed-water service throughout the world.
Stainless steel spacer rings on gate valves, fitted between wedge halves	Simplify service. Damaged valve seats can be restored to factory fit by in-line replacement with slightly thicker ring.
Unique two-piece, flexible wedges on gate valves	Automatically adjust to any angular distortion of body seats. Shape provides greater flexibility. Ensure dependable sealing and prevent sticking.
Impactor handwheels and handles	Allow workers to generate several thousand foot-pounds of torque, thus ensuring tight shutoff of manually operated globe and angle valves.
Inclined-bonnet globe valves with streamlined flow passages	Minimize pressure drop due to flow.
Globe valves available with both vertical and inclined stems	Provide stem designs suited to any installation.
Live-loaded pressure energized PressurSeat® for globe valves	Globe valve design for high-pressure drain and vent service.
Shipped first N-stamp valve	Early and uninterrupted support for the nuclear industry.
First gate valve for the MSIV service	Lower pressure drop and reduced actuator size.
First gas-hydraulic actuator for MSIVs	Self-contained actuator independent of outside systems.
First to qualify a valve to ASME QME-1	Proven dedication to evolving industry requirements.

## Flowserve - Edward and Anchor/Darling Valves Available for Nuclear Service

The vast majority of Edward and Anchor/Darling forged and cast steel valves can be supplied for nuclear service. The following chart summarizes past Edward and Anchor/Darling valve experience by Type, Size Range and Pressure Class. Consult your Flowserve Edward valves sales representative for additional information.

	Valve Type	Size	ANSI Ratings
<b>Forged Steel Valves</b>	Bolted Bonnet	½ (15) Thru 2 (50)	Thru Class 600
	Hermavalue	½ (15) Thru 2-½ (65)	Thru Class 1690
	Univalve	½ (15) Thru 4 (100)	Thru Class 2500
	Soft Seated Check Valve	½ (15) Thru 4 (100)	Thru Class 2500
<b>Cast Steel</b>	800 Series (Gate, Globe & Check)	½ (15) Thru 2 (50)	Thru Class 800
	1878/1888 Series (Gate, Globe & Check)	½ (15) Thru 2 (50)	Thru Class 1878
	Equiwedge Gate	2-½ (65) - 28 (700)	Thru Class 2500
	Flex Wedge Gate		
	Double-Disc Gate		
	Flite-Flow Globe (Stop, Stop-Check & Check)	3 (80) - 32 (800)	Thru Class 2500
	Tilting-Disc Check	2-½ (65) - 24 (600)	Thru Class 2500
	Swing Check	2-½ (65) - 32 (800)	
	In-Line Check	1 (30) Thru 2-½ (65)	Thru Class 1500
	Globe and Angle Valves (Stop, Stop Check & Check)	2-½ (65) - 24 (600)	Thru Class 2500
	Controlled Closure Check Valve (See page 113 or 191)	2-½ (65) - 24 (600)	Thru Class 2500
Soft Seated Check Valve	2-½ (65) - 24 (600)	Thru Class 2500	
<b>Actuators (U-stamped)</b>	Stored Energy (Gas-Hydraulic)	A-100 Thru A-510 and B-100 Thru B-510	Thrusts from 20,000 to over 489,000 lbs.
<b>¼ Turn Valve</b>	Top Entry Ball Valves	½ (15) Thru 10 (250)	Thru Class 600
	3-Piece Ball Valves	¾ (20) Thru 10 (250)	Thru Class 300
	Butterfly Valves	3 (80) Thru 20 (500)	Thru Class 600

Note: See pages 5 and 10 for indicated figure numbers available for nuclear service.

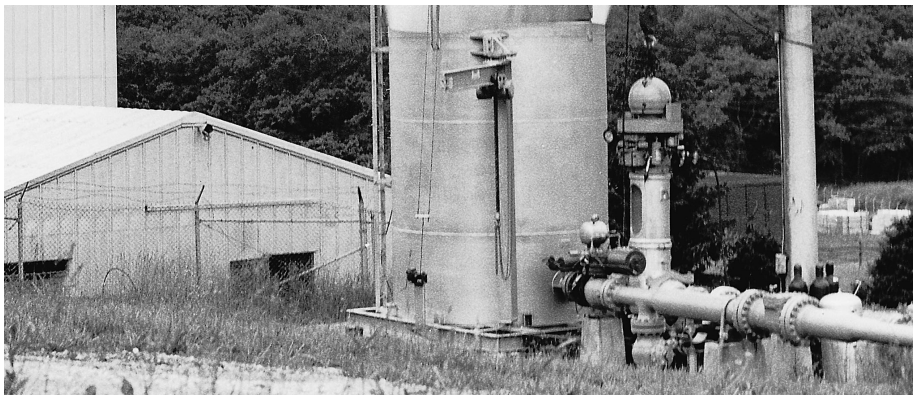

**Edward and Anchor/Darling valves constructed for nuclear service can be offered for Code Class 1, 2 or 3.**

*Simulated line rupture test confirms closing speed of Edward main steam isolation valve against differential pressure of 1500 psi.*

## Flowserve Forged and Cast Steel Valves for Nuclear Service

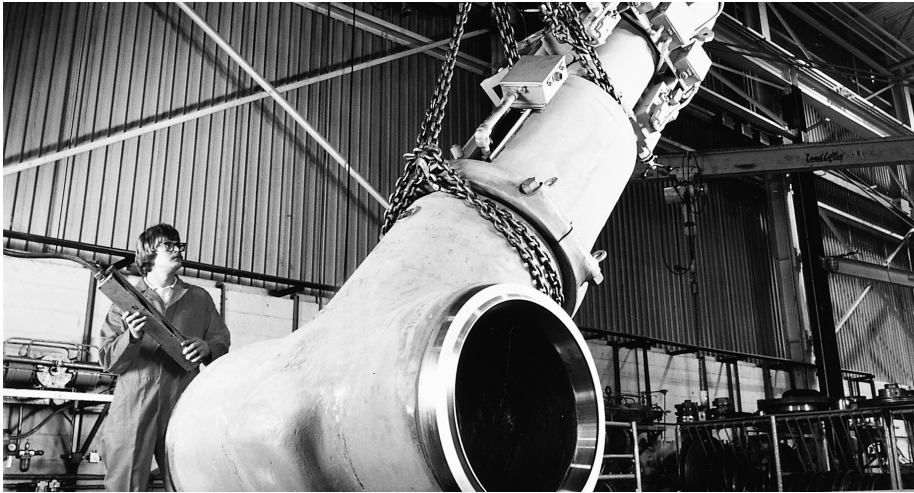

*Edward Equiwedge gate valve with an Edward gas hydraulic actuator being prepared for shipment.*

Flowserve Edward and Anchor/Darling have been serving the power generation and process industries with custom engineered valves since 1888.

As a specialist with more than 100 years of experience in the production of high-specification valves for critical services, we are uniquely qualified to serve the needs of the power generation and process industries worldwide.

From the beginning of commercial nuclear power production, Flowserve valves have been used successfully in many of the most difficult applications. The Shippingport plant went on line in 1957 with special size 18" Edward stainless steel tilting disc check and Anchor/Darling 10" double-disc gate valves in its primary coolant system. It also incorporated numerous small Edward capped manual valves. Other "first generation" commercial nuclear plants are still in operation with a broad variety of Edward and Anchor/Darling forged and cast steel valves.

Through the evolution of the pressurized water reactor (PWR), the boiling water reactor (BWR) and even the liquid metal fast breeder reactors (LMFBR), Flowserve Flow Control has been involved in meeting the most difficult challenges. This experience in engineering, manufacturing and quality assurance provides an excellent basis for supplying superior valves for nuclear service — in new construction, retrofit and life extension work.

A major Flowserve Edward Valves nuclear niche has been the main steam and feedwater isolation market (MSIVs and MFIVs). These safety-related valves must close rapidly, typically in three to five seconds, to prevent major leakage in the event of a pipe rupture. Special Edward Flite-Flow valves with air/spring actuators were used in PWRs until the Edward Equiwedge gate valve and stored energy actuator were developed in the late 1970s. Edward Equiwedge MSIVs and MFIVs with stored energy actuators are now in service on three continents—in PWRs and in steam service in an LMFBR.

Other critical nuclear applications are served by Edward check and stop-check valves, some with special features. Flowserve provides comprehensive application engineering data (see Technical Section) to support these valves, helping to avoid many of the problems that have occurred with other check valves in nuclear power plants.

In addition, thousands of small Edward forged steel valves are widely used in many nuclear plant applications that demand high reliability. Some have handwheels, some have electric motor actuators and some have pneumatic actuators, but all are designed and built to nuclear standards. Univalves and bolted bonnet valves provide excellent service in most applications, and Hermavalves are available for applications where the risk of external leakage is unacceptable.

A major manufacturer of Section III Nuclear Valves, ½" and larger Flowserve Edward and Anchor/Darling offer the most complete

line of valves developed for nuclear service where reliable operation, positive sealing, ease of maintenance and A.L.A.R.A. are prime considerations. Our valves are produced in the U.S.A. to an ISO 9001 certified quality program.

Flowserve Edward and Anchor/Darling small-bore valves are available to ASME Section III Class 1, 2, 3 or ANSI B16.34 requirements.

Flowserve Edward and Anchor/Darling valves are available with seating materials suitable for various applications. Where required, seat rings are firmly shouldered against the body and vacuum furnace brazed. This process gives a very precise seating surface to achieve extended service life. Seating surfaces are solid alloys that provide excellent wear and corrosion properties not possible with competitors' integral seat designs often seen in forged valves.

Hardface materials offered as a standard include non-cobalt NOREM, cobalt-chrome Stellite and various nickel-based alloys.

Since there were 50 years of Flowserve power plant valve experience before the first nuclear plants were built, we were well prepared for the new challenges of first-generation nuclear power plants. Now, with over 50 years of nuclear valve experience, Flowserve Edward and Anchor/Darling valves are even better prepared for the challenges of the future.

*Edward and Anchor/Darling valves constructed for nuclear service can be offered for Code class 1, 2 or 3.*

## ***Checklist of Customer Information Required for Nuclear Valve Proposals***

The following checklist is provided as a guide of important information required by the valve manufacturer to accurately quote equipment intended for nuclear service. By properly identifying this data, a more complete and specific proposal can be provided.

- Certified design specifications.
- Nuclear code class.
- Applicable codes/standards and date of issue.
- Estimated delivery requirements.
- Environmental conditions - temperature, humidity, radiation, exposure to elements.
- Piping diagrams.
- Pipe size, material, wall thickness.
- Piping forces transmitted to valve.
- Piping response spectrum to Design Basis Earthquake.
- Dimensional limitations of valve envelope.
- Physical orientation of valve - horizontal, vertical, bonnet position.
- Special materials required.
- Special butt weld end requirements.
- System design conditions - pressure, temperature.
- Normal operating conditions - pressure, temperature.
- Normal flow - pounds per hour.
- Maximum flow - pounds per hour.
- Allowable pressure drop through valve.
- Flow direction through valve.
- Active/non-active valve operational requirements - emergency opening or closing, actuation time, differential pressures and flows during operation.
- Power sources - air supply pressure (maximum and minimum) voltage supply (AC, DC), cycles, fluctuation.
- Actuator type desires.
- Safety related function.
- Qualification requirement.

## ***Flowserve Edward Stored Energy Actuator***

Unlike a safety-related motor operator, designed to open and close a valve upon being enabled by the control room, Flowserve Edward's Gas/Hydraulic – Stored Energy Actuator is primarily designed to rapidly close a Main Steam Isolation Valve or a Main Feed Water Valve in response to a seismic event, or other containment threat. Upon activation of the actuator, in response to such an event, the compressed nitrogen in the hemisphere at the top of the unit immediately closes the valve in as little as two (2) seconds. The system includes a hydraulic reservoir and pump either electrically driven or pneumatically driven. The pump is capable of recompressing the nitrogen into the storage hemisphere to reposition the valve in the open position; simultaneously, the actuator is reset to the ready position. This same mechanism is designed to allow the valve to be exercised (partial stroked) by operators and service technicians.

The Flowserve Edward Stored Energy Actuator is built in accordance with ASME Section VIII where required and is fully certified to the applicable IEEE environmental qualification standards. These Flowserve Edward Stored Energy Actuators are in active nuclear service throughout the world.

Contact Flowserve Inc. Flow Control for a listing of U.S. and international users.

## Gas-Hydraulic Actuators for Fail-Safe Isolation Valves



Flowserve Edward gas-hydraulic actuator for large, fast-closing valves is subjected to seismic testing during rigorous qualification program to provide dependability of operation under the most adverse conditions.

### Standard Features

- Stored energy (pressurized nitrogen) integrally contained.
- Hydraulic speed-control system ensures constant valve stroking speed regardless of stem load.
- Fail-safe operation to either close or open valve within an adjustable range of 2 to 10 seconds.
- Self-contained control system, fully manifolded.
- All safety-related functional components are duplicated for redundancy.
- Exercise capability demonstrates operation of all safety-related components online.
- Qualified to applicable IEEE requirements.
- Actuators equipped with Edward IEEE-qualified AC or DC operated hydraulic solenoid valves.
- Fire safe, non-toxic hydraulic fluid.

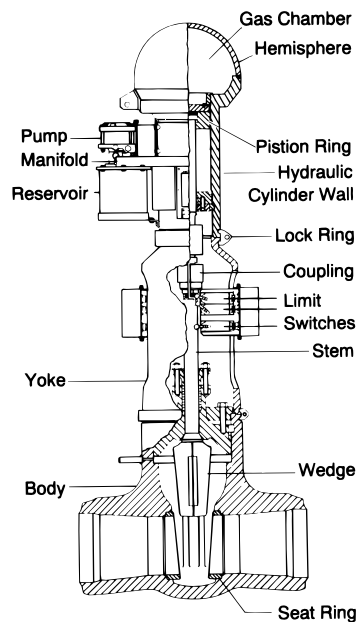

Diagram of Flowserve Edward Equiwedge gate valve and gas-hydraulic actuator assembly.

### Flowserve - Edward Actuator Designation

Black numerals are in inches and pounds  
Colored numerals are in millimeters and kilograms

	Units	A/B-100	A/B-180	A/B-230	A/B-260	A/B-290	A/B-330	A/B-510
Closing Thrust	lb.	21,000	63,000	90,000	130,000	160,000	205,000	489,000
	kN	93	293	400	578	712	912	2175
Travel	in.	6.5	12	14	17.5	20.5	24	32
	mm	165	305	356	446	521	610	813
Weight (Mass)	lb.	720	1720	2270	2950	3940	5260	17,700
	kg	325	780	1030	1340	1790	2390	8030
Extension Time	sec.	3 - 10 SECONDS (ADJUSTABLE)						

Values tabulated are "nominal." For special applications; otherwise, standard actuators may be modified for shorter or longer travel with corresponding effects on weight. Environmental temperature range of the application will influence thrust.

## Main Steam and Main Feedwater Isolation Valves

### Gas / Hydraulic Actuated Equiwedge Gate Valves

- Single stored energy system / redundant control systems.
- Standard features include:
  - Manifold-mounted hydraulic components
  - Off-line testing capabilities
  - Exercise stroke capabilities
  - Extended periods between maintenance
  - No external hose or piping connections
- Similar in weight and smaller than pneumatic actuators.
- Consistent stroke times.
- Fluid filtration systems prevent particulate contamination of hydraulic fluid.
- Environmental qualification to IEEE-382, 323 and 344.
- ASME B16.41 and QME-1 functionally qualified.

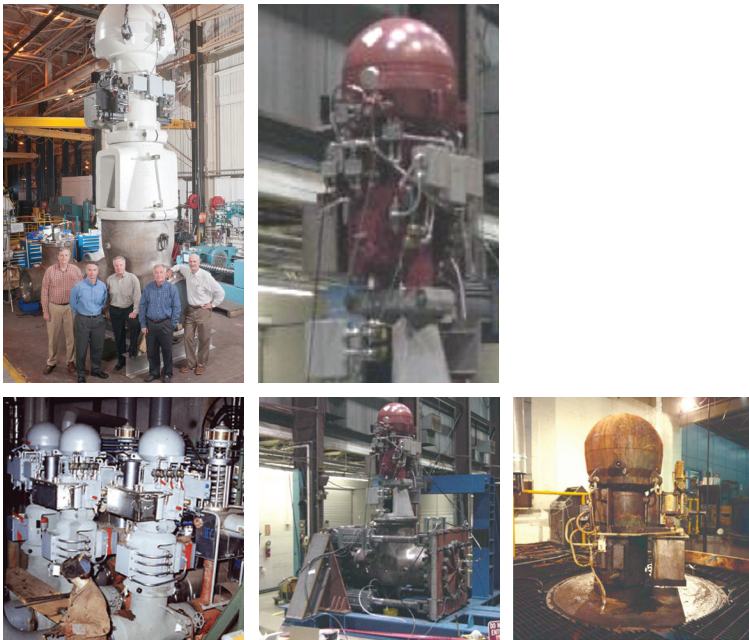

Since 1985, over 80% of the world's MSIVs and MFIVs have been supplied by Flowserve!

- Simple design and operating principle
- Extensive, proven track record
- Environmentally and functionally qualified valve and actuator
- Flowserve service, training and warranty
- No failures to perform safety-related function
- Over 9,000 service years of reliable operation





## Edward Gate Valves

## Features and Description of Flowserve Edward Equiwedge® Gate Valves

For detailed description of the two-piece flexible wedge, see page 28.

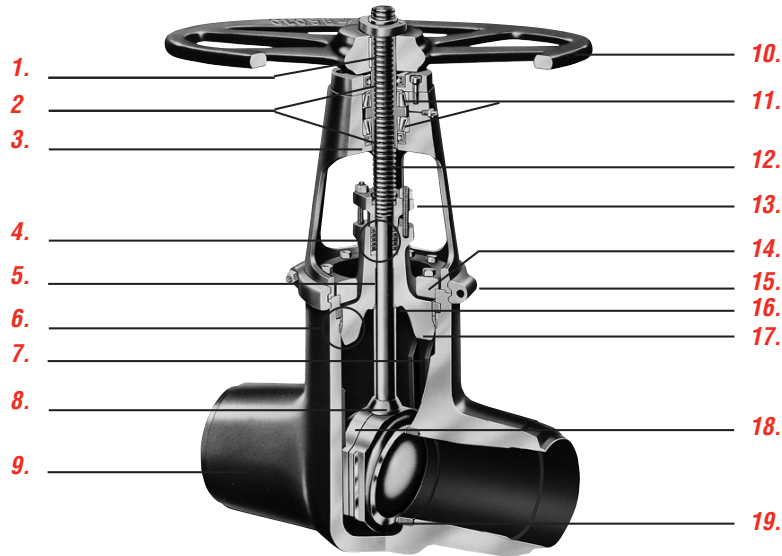

- 1. Yoke bushing** – material has low coefficient of friction that substantially reduces torque and thread wear and eliminates galling.
- 2. Weather/Grease seals** – are provided to protect against environmental conditions.
- 3. Yoke** – the yoke is designed for ready access to the packing chamber.
- 4. Packing and junk ring** – utilizes flexible graphite packing material with anti-extrusion rings for optimum sealability and life.
- 5. Extended bonnet design** – further separates the packing chamber from fluid flow area for longer packing life. Also provides accessible area for leakoff connections if required.
- 6. Composite pressure seal gasket** – preloaded, pressure energized design, for long, reliable service.
- 7. Body guiding system** – holds the wedge halves together and absorbs thrust loads due to line flow. Integral hardfaced guide system components reduce friction and prevent galling for longer valve life.
- 8. Conical stem backseat** – Cone-on-cone design provides a reliable sealing geometry that operates over many valve cycles without leakage.
- 9. Body** – rugged cast steel body provides maximum flow efficiency. Information on alternate materials can be obtained through your Flowserve representative.
- 10. Handwheel** – spoke design provides more efficient transfer of load with minimum weight.
- 11. Tapered roller bearings** – on larger valves, tapered roller bearings reduce torque, carry the stem thrust and provide additional radial support for side loads imposed by handwheel or power actuator. Smaller size valves have needle roller bearings.
- 12. Stem** – has ACME threads, is machined to a fine finish and is heat treated for improved strength and hardness to resist wear.
- 13. Packing gland** – made of alloy steel, and retained against the stuffing box pressure by an easy-to-maintain stud and heavy hex nut assembly.
- 14. Bonnet retaining ring** – ensures an effective, tight seal by pulling the bonnet and gasket together at the pressure seal.
- 15. Yoke lock ring** – permits easier field maintenance of upper structure without disturbing pressure-containing parts. Valves in smaller sizes utilize a wishbone yoke design. Class 600 valves utilize a bolted pressure seal bonnet.
- 16. Bonnet backseat** – especially hardfaced to ensure long-term sealability.
- 17. Hemispherical-type bonnet** – reduces valve body height and provides weight saving. Hemispherical-type design results in better pressure distribution across the bonnet area.
- 18. Two-piece wedge assembly** – allows each wedge half to flex and adjust independently to compensate for body distortions caused by thermal changes or pipe bending stresses. (see pg. C10)
- 19. Welded-in seat ring with hardfaced seat** – ensures better wear and longer valve life. Seat ring is welded into the valve body to prevent leakage.

## Parts Specification List for Edward Gate Valves

This is not a complete list. Construction and materials will vary between sizes and pressure classes and may be changed without notice. For a complete, accurate and itemized description of a particular valve, contact your Flowserve valves sales representative.

Description	ASME No.	ASME No.	ASME No.	ASME No.
<b>Body/Bonnet*</b>	SA-216 Grade WCB	SA-216 Grade WCC	SA-217 Grade WC9	SA-351 Grade CF8M
<b>Gate 2½-6</b>	SA-732 Grade 21	SA-732 Grade 21	SA-732 Grade 21	SA-732 Grade 21
<b>Gate 8 and up*</b>	SA-216 Grade WCB	SA-216 Grade WCB	SA-217 Grade WC9	SA-351 Grade CF8M
<b>Stem</b>	A-182 Grade F6 CL4	A-182 Grade F6 CL4	A-565 Grade 616 HT	A-638 Grade 660 T2
<b>Yoke Bushing</b>	B-148 Alloy 95400	B-148 Alloy 95400	B-148 Alloy 95400	B-148 Alloy 95400
<b>Packing Rings</b>	Flexible Graphite inner rings and suitable anti-extrusion rings.			
<b>Junk Rings</b>	AISI 1117 MnPO <sub>4</sub> Plated	AISI 1117 MnPO <sub>4</sub> Plated	AISI 1117 MnPO <sub>4</sub> Plated	A-182 Grade F316/Stellite I.D.
<b>Pressure Seal Gasket</b>	Composite Pressure Seal Gasket.			
<b>Spacer Ring</b>	— A-668 Grade 4140 MnPO <sub>4</sub> Plated	— A-668 Grade 4140 MnPO <sub>4</sub> Plated	— A-668 Grade 4140 MnPO <sub>4</sub> Plated	— A-182 Grade F6 CL4
<b>Gasket Retainer</b>	A-182 Grade F6 CL4	A-182 Grade F6 CL4	A-565 Grade 616 HT	A-638 Grade 660 T2
<b>Bonnet Retainer</b>	A-515 Grade 70	A-515 Grade 70	A-515 Grade 70	A-515 Grade 70
<b>Bonnet Retainer Studs</b>	A-193 Grade B7	A-193 Grade B7	A-193 Grade B7	A-193 Grade B7
<b>Bonnet Retainer Nuts</b>	A-194 Grade 2H	A-194 Grade 2H	A-194 Grade 2H	A-194 Grade 2H
<b>Gland</b>	A-148 Grade 90-60	A-148 Grade 90-60	A-148 Grade 90-60	A-148 Grade 90-60/Chrome Plated
<b>Gland Studs</b>	A-193 Grade B7	A-193 Grade B7	A-193 Grade B7	A-193 Grade B7
<b>Gland Nuts</b>	A-194 Grade 2H	A-194 Grade 2H	A-194 Grade 2H	A-194 Grade 2H
<b>Yoke</b>	A-216 Grade WCB	A-216 Grade WCB	A-216 Grade WCB	A-216 Grade WCB
<b>Yoke Lock Ring</b>	A-216 Grade WCB	A-216 Grade WCB	A-216 Grade WCB	A-216 Grade WCB
<b>Yoke Lock Ring Studs</b>	A-193 Grade B7	A-193 Grade B7	A-193 Grade B7	A-193 Grade B7
<b>Yoke Lock Ring Nuts</b>	A-194 Grade 2H	A-194 Grade 2H	A-194 Grade 2H	A-194 Grade 2H
<b>Handwheel</b>	A-126 Class A	A-126 Class A	A-126 Class A	A-126 Class A

\*Hardfaced wedge guide rails and seating surfaces.

\*\*Use A-368 Grade 660 T2 for applications over 1100°F

## Features and Description of Flowserve Edward Equiwedge® Gate Valves

### Unique Two-Piece Flexible Wedge

Wedging action provides tight seat sealing, even at low differential pressures. Wedge guiding by grooves in body minimizes seat wear and damage, since seating surfaces of wedge and body are in contact over less than 5% of total travel. Two separate, flexible wedge halves are free to align with seats even when they are tilted or rotated due to thermal effects or piping loads. Resistance to thermal binding ensures opening with a torque or load less than design closing load.

Wedge guide area and strength provide capability to support high differential pressures with valve partially open, so Equiwedge gate valves can be opened or closed under “blowdown” conditions. Bypasses are not required if full differential is specified for actuator sizing.

### Center Cavity Overpressurization

Some valve designs are capable of sealing simultaneously against a pressure differential between an internal cavity of the valve and the adjacent pipe in both directions. Double-seated gate valves, including Equiwedge, are examples of such a design. In fact, seat joint integrity for these valves is tested in the factory by pressurizing the center cavity and simultaneously examining each seat. However, if a fluid is entrapped in such a valve while closed, and then subsequently heated, a dangerous rise in pressure can result, thus leading to pressure boundary failure.

Both ASME B16.34 (Valves - Flanged, Threaded and Welding End), para 2.3.3 and ASME B31.1 (Pressure Piping Code), para 107.1(c), recognize this situation and require that the Purchaser shall provide means in design, installation and/or operation to ensure that the pressure in the valve shall not exceed the rated pressure for the attained temperature. Therefore, if deemed necessary by the Purchaser, and so specified in the purchase order, Flowserve Edward Valves can provide an equalizer system (internal or external) that will relieve this trapped fluid to the upstream piping or a relief valve that will exhaust excessive pressure to some other specified area. It should be understood that an internal or external equalizer will change a basically bidirectional gate valve to a

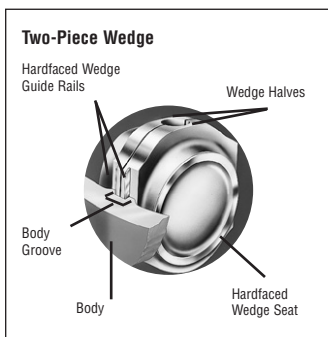

**Figure 1**

The outstanding design feature of the Equiwedge gate valve is unique two-piece wedge that permits maximum independence and flexibility for good sealability and freedom from sticking.

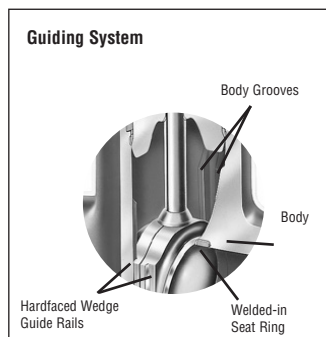

**Figure 2**

The body groove extends high in the body neck region so that in the open position the wedge assembly is both trapped and fully guided. Body grooves are hardfaced for critical service valves.

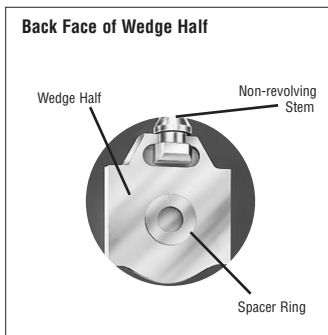

**Figure 3**

Wedge halves are separated the proper amount by a spacer ring which provides controlled deflection from stem loading. Use of a space and weight-saving “captured stem” (shown here and in Figure 4) is possible because of the two-piece wedge design.

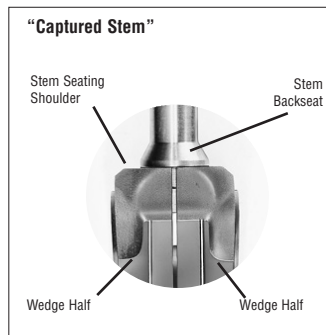

**Figure 4**

The Equiwedge two-piece wedge design allows the use of a space and weight-saving “captured stem.”

design with fully effective seat sealing in only one direction. The equalizer bypasses the upstream seat and would allow leakage by that seat if the pressure should be reversed. The “downstream” seat would become the “upstream” seat with pressure reversed; the wedging action provided by stem load provides good upstream seat sealing at low to moderate pressures, but leakage could be excessive at high pressures.

Excessive pressure trapped in the center cavity of a gate valve can also produce

“pressure locking”—a condition that can make opening difficult or impossible. Either an internal or an external equalizer will prevent pressure locking. However, a relief valve may allow the center cavity pressure to be higher than either the upstream or downstream pressure, and this can allow pressure locking to occur. The Flowserve Edward valves’ unique ACEV (Automation Center Cavity Equalizing Valve) can alleviate this problem. Refer to page 197 for additional information.

## Equiwedge Stop Valves, Class 600

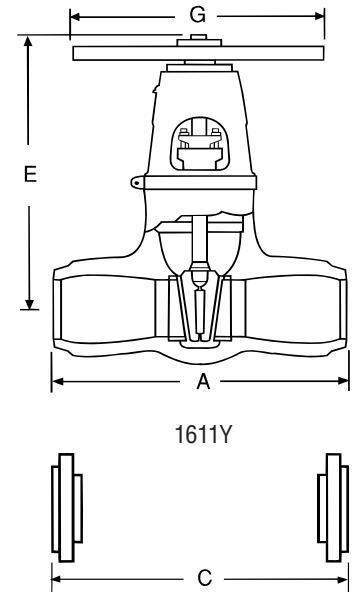

### Standard Features

- Bodies and bonnets are cast steel (WCB, WCC, WC9, CF8M)
- Pressure-seal bonnet OS & Y
- Integral Stellite seats and backseat
- Two-piece body-guided wedge
- 13% chromium stainless steel stem
- Asbestos-free graphitic packing
- Composite pressure-seal gasket
- Available in standard or venturi pattern
- Yoke bushing thrust bearings

### Pressure Class 600 (PN 110)

Fig. No.		Type	Ends	Bonnet	NPS (DN)
STD CL	SPL CL				
1611*	—	Equiwedge Gate	Flanged	Pressure Seal	2½ (65) thru 28 (700)
1611Y	1711Y	Equiwedge Gate	Butt Weld	Pressure Seal	
1611BY	1711BY	Venturi Pattern	Butt Weld	Pressure Seal	8 (200) thru 32 (800)
		Equiwedge Gate			

\* Flanges to size 24 only.

### Dimensions – Equiwedge Gate

Black numerals are in inches and pounds  
Colored numerals are in millimeters and kilograms

Figure No. 1611/1611Y, 1711Y	NPS	2½	3	4	6	8	10	12	14
	DN	65	80	100	150	200	250	300	350
A - End to End (Welding)		10	10	12	18	23	28	32	35
		254	254	305	457	584	711	813	889
C - Face to Face (Flanged)		13	14	17	22	26	31	33	35
		330	356	432	559	660	787	838	889
E - Center to Top, (Open)		22.25	22.25	25.5	31.75	39.75	48	54	58.5
		565	565	648	806	1010	1219	1372	1486
G - Handwheel Diameter		14	14	14	24	24	30	30	36
		356	356	356	610	610	762	762	914
Weight (Welding)		81	81	175	372	667	1050	1623	2345
		37	37	79	169	303	476	738	1066

\* E, G, and other dimensions and information supplied upon request.  
Refer to page 27 for materials of construction.  
Refer to pages 203 through 238 for the applicable pressure ratings.



## Equiwedge Stop Valves, Class 600

### Dimensions – Equiwedge Gate (continued)

Black numerals are in inches and pounds  
Colored numerals are in millimeters and kilograms

Figure No. 1611/1611Y, 1711Y	NPS	16	18	20	22	24	26	28
	DN	400	450	500	550	600	650	700
A - End to End (Welding)		39	43	47	51	55	57	61
		991	1092	1194	1295	1397	1448	1549
C - Face to Face (Flanged)		39	43	47	51	55	57	61
		991	1092	1194	1295	1397	1448	1549
E - Center to Top, (Open)		67	76	82.75	89	96	101	110.5
		1702	1930	2102	2261	2438	2565	2807
G - Handwheel Diameter		36	36	36	48	48	48	48
		914	914	914	1219	1219	1219	1219
Weight (Welding)		2950	3600	5000	5700	6500	8000	10,000
		1338	1633	2268	2585	2948	3628	4535

\* E, G and other dimensions and information supplied upon request.

### Dimensions – Equiwedge Gate Venturi Pattern

Black numerals are in inches and pounds  
Colored numerals are in millimeters and kilograms

Figure No. 1611BY, 1711BY	NPS	8x6x8	10x8x10	12x10x12	14x12x14	16x14x16	18x16x18
	DN	200	250	300	350	400	450
A - End to End (Welding)		18	23	28	32	35	39
		457	584	711	813	889	991
E - Center to Top, (Open)		31.75	39.75	48	54	58.5	67
		806	1010	1219	1372	1486	1702
G - Handwheel Diameter		24	24	30	30	36	36
		610	610	762	762	914	914
Weight (Welding)		372	610	1114	1623	2345	2950
		169	277	506	738	1066	1338

Figure No. 1611BY, 1711BY	NPS	20x18x20	22x20x22	24x20x24	26x22x26	28x24x28	30x26x30	32x28x32
	DN	500	550	600	650	700	750	800
A - End to End (Welding)		43	47	47	51	55	57	61
		1092	1194	1194	1295	1397	1448	1549
E - Center to Top, (Open)		76	82.75	82.75	89	96	101	110.5
		1930	2102	2102	2261	2438	2565	2807
G - Handwheel Diameter		36	36	48	48	48	48	48
		914	914	1219	1219	1219	1219	1219
Weight (Welding)		3600	5000	5700	6500	7000	8500	10,500
		1633	2268	2585	2948	3175	3855	4762

Refer to page 27 for materials of construction.

Refer to pages 203 through 238 for the applicable pressure ratings.

## Equiwedge Stop Valves, Class 900

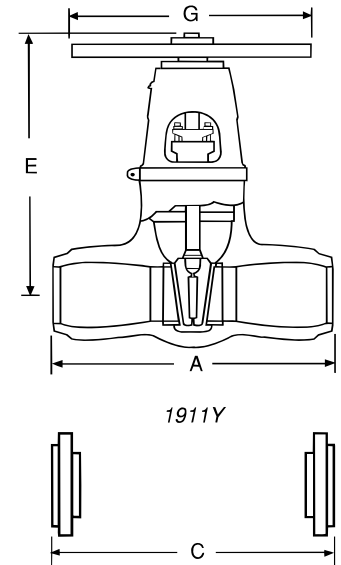

### Standard Features

- Bodies and bonnets are cast steel (WCB, WCC, WC9, CF8M)
- Pressure-seal bonnet, OS and Y
- Integral Stellite seat, disc and backseat
- Two-piece body-guided wedge
- 13% chromium stainless steel stem
- Asbestos-free graphitic packing
- Available in standard or venturi pattern
- Yoke bushing thrust bearings
- Composite pressure seal gasket

### Pressure Class 900 (PN 150)

Fig. No.		Type	Ends	Bonnet	NPS (DN)
STD CL	SPL CL				
1911	—	Equiwedge Gate	Flanged	Pressure-Seal	2½ (65) thru 28 (700)
1911Y	14311Y	Equiwedge Gate	Butt Weld	Pressure-Seal	
1911BY	14311BY	Venturi Pattern Equiwedge Gate	Butt Weld	Pressure-Seal	8 (200) thru 32 (800)

### Dimensions – Equiwedge Gate

Black numerals are in inches and pounds  
Colored numerals are in millimeters and kilograms

Figure No. 1911/1911Y, 14311Y	NPS	2½	3	4	6	8	10	12	14
	DN	65	80	100	150	200	250	300	350
A - End to End (Welding)		12	12	14	20	26	31	36	39
		305	305	356	508	660	787	914	991
C - Face to Face (Flanged)		16.5	15	18	24	29	33	38	40.5
		419	381	457	610	737	838	965	1029
E - Center to Top (Open)		21.25	21.25	24.5	33.5	40	46.75	54.5	59
		540	540	622	851	1016	1187	1384	1499
G - Handwheel Diameter		14	14	18	24	24	36	36	36
		356	356	457	610	610	914	914	914
Weight (Welding)		95	125	165	380	690	1523	2118	2805
		43	57	75	172	313	692	963	1275

Refer to page 27 for materials of construction.  
Refer to pages 203 through 238 for the applicable pressure ratings.



## Equiwedge Stop Valves, Class 900

### Dimensions – Equiwedge Gate (continued)

Black numerals are in inches and pounds  
Colored numerals are in millimeters and kilograms

Figure No. 1911/1911Y, 14311Y	NPS	16	18	20	22	24	26	28
	DN	400	450	500	550	600	650	700
A - End to End (Welding)		43	48	52	57	61	64	68
		1092	1291	1321	1448	1549	1626	1727
C - Face to Face (Flanged)		44.5	48	52	57	61	Available Upon Request	
		1130	1291	1321	1448	1549		
E - Center to Top (Open)		68	73.75	82	89.25	95	102	109
		1727	1873	2083	2267	2413	2591	2769
G - Handwheel Diameter		36	36	48	48	48	60	60
		914	914	1219	1219	1219	1524	1524
Weight (Welding)		4150	4300	5800	7500	9600	12,000	
		1882	1950	2631	3402	4355	5443	

### Dimensions – Equiwedge Gate Venturi Pattern

Black numerals are in inches and pounds  
Colored numerals are in millimeters and kilograms

Figure No. 1911BY, 14311BY	NPS	8x6x8	10x8x10	12x10x12	14x12x14	16x14x16	18x16x18
	DN	200	250	300	350	400	450
A - End to End (Welding)		20	26	31	36	39	43
		508	660	787	914	991	1092
E - Center to Top (Open)		33.5	40	46.75	54.5	59	68
		851	1016	1187	1384	1499	1727
G - Handwheel Diameter		24	24	36	36	36	36
		610	610	914	914	914	914
Weight (Welding)		530	891	1523	2118	2805	4150
		241	405	692	963	1275	1882

Figure No. 1911BY, 14311BY	NPS	20x18x20	22x20x22	24x20x24	26x22x26	28x24x28	30x26x30	32x28x32
	DN	500	550	600	650	700	750	800
A - End to End (Welding)		48	52	52	57	61	64	68
		1219	1321	1321	1448	1549	1626	1727
E - Center to Top (Open)		73.75	82	82	89.25	95	102	109
		1873	2083	2083	2267	2413	2591	2769
G - Handwheel Diameter		36	48	48	48	48	60	60
		914	1219	1219	1219	1219	1524	1524
Weight (Welding)		4500	6970	7200	8000	10,000	12,500	15,000
		2041	3162	3266	3629	4536	5670	6804

Refer to page 27 for materials of construction.  
Refer to pages 203 through 238 for the applicable pressure ratings.



## Equiwedge Stop Valves, Class 1500

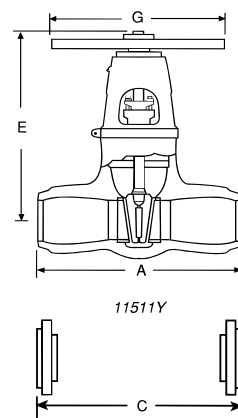

### Standard Features

- Bodies and bonnets are cast steel (WCB, WCC, WC9, CF8M)
- Pressure-seal bonnet, OS & Y
- Integral Stellite seats and backseat
- Two-piece body-guided wedge
- 13% chromium stainless steel stem
- Asbestos-free graphitic packing
- Available in standard or venturi pattern
- Yoke bushing thrust bearings

### Pressure Class 1500 (PN 260)

Fig. No.		Type	Ends	NPS (DN)
STD CL	SPL CL			
11511	—	Equiwedge Gate	Flanged*	2½ (65) thru 24 (600)
11511Y	12011Y	Equiwedge Gate	Butt Weld	
11511BY	12011BY	Venturi Pattern Equiwedge Gate	Butt Weld	8 (200) thru 28 (700)

\* Optional weld-on flanges.

### Dimensions – Equiwedge Gate

Black numerals are in inches and pounds  
Colored numerals are in millimeters and kilograms

Figure No. 11511/11511Y, 12011Y	NPS	2½	3	4	6	8	10	12
	DN	65	80	100	150	200	250	300
A - End to End (Welding)		12	12	16	22	28	34	39
		305	305	406	559	711	864	991
C - Face to Face (Flanged)		16.5	18.5	21.5	27.75	32.75	39	44.5
		419	470	546	705	832	991	1130
E - Center to Top (Open)		21.25	21.25	24.25	31.5	40	48.25	55.25
		540	540	616	800	1016	1226	1403
G - Handwheel Diameter		14	14	18	24	36	36	36
		356	356	457	610	914	914	914
Weight (Welding)		125	125	190	490	675	1730	2725
		57	57	86	222	306	785	1236

Figure No. 11511/11511Y, 12011Y	NPS	14	16	18	20	22	24
	DN	350	400	450	500	550	600
A - End to End (Welding)		42	47	53	58	67	76.5
		1067	1194	1346	1473	1702	1943
C - Face to Face (Flanged)		49.5	54.5	60.5	65.5	71	76.5
		1257	1384	1537	1664	1803	1943
E - Center to Top (Open)		61	68.75	73.75	80	86.75	93.5
		1549	1746	1873	2032	2203	2375
G - Handwheel Diameter		48	48	48	60	60	60
		1219	1219	1219	1524	1524	1524
Weight (Welding)		3660	4450	6000	8000	10,500	13,000
		1660	2019	2722	3629	4763	5897

Refer to page 27 for materials of construction.

Refer to pages 203 through 238 for the applicable pressure ratings.

## Equiwedge Stop Valves, Class 1500

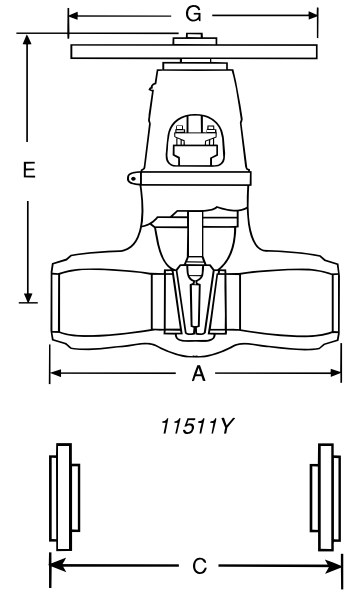

### Dimensions – Equiwedge Gate Venturi Pattern

Black numerals are in inches and pounds  
Colored numerals are in millimeters and kilograms

Figure No. 11511BY, 12011BY	NPS	8x6x8	10x8x10	12x10x12	14x12x14	16x14x16	18x16x18
	DN	200	250	300	350	400	450
A - End to End (Welding)		22	28	34	39	42	47
		559	711	864	991	1067	1194
E - Center to Top (Open)		31.5	40	48.25	55.25	61	68.75
		800	1016	1226	1403	1549	1746
G - Handwheel Diameter		24	36	36	36	48	48
		610	914	914	914	1219	1219
Weight (Welding)		490	1082	1690	2725	3600	4600
		222	491	767	1236	1633	2087

Figure No. 11511BY, 12011BY	NPS	20x18x20	22x20x22	24x20x24	26x22x26	28x24x28
	DN	500	550	600	650	700
A - End to End (Welding)		53	58	58	67	76.5
		1346	1473	1473	1702	1943
E - Center to Top (Open)		73.75	80	80	86.75	93.5
		1873	2032	2032	2203	2375
G - Handwheel Diameter		48	60	60	60	60
		1219	1524	1524	1524	1524
Weight (Welding)		6200	8200	8,500	11,000	13,500
		2812	3720	3855	4990	6124

Refer to page 27 for materials of construction.  
Refer to pages 203 through 238 for the applicable pressure ratings.

## Anchor/Darling Gate Valves

## Features and Description of Anchor/Darling 800 Series Gate Valves

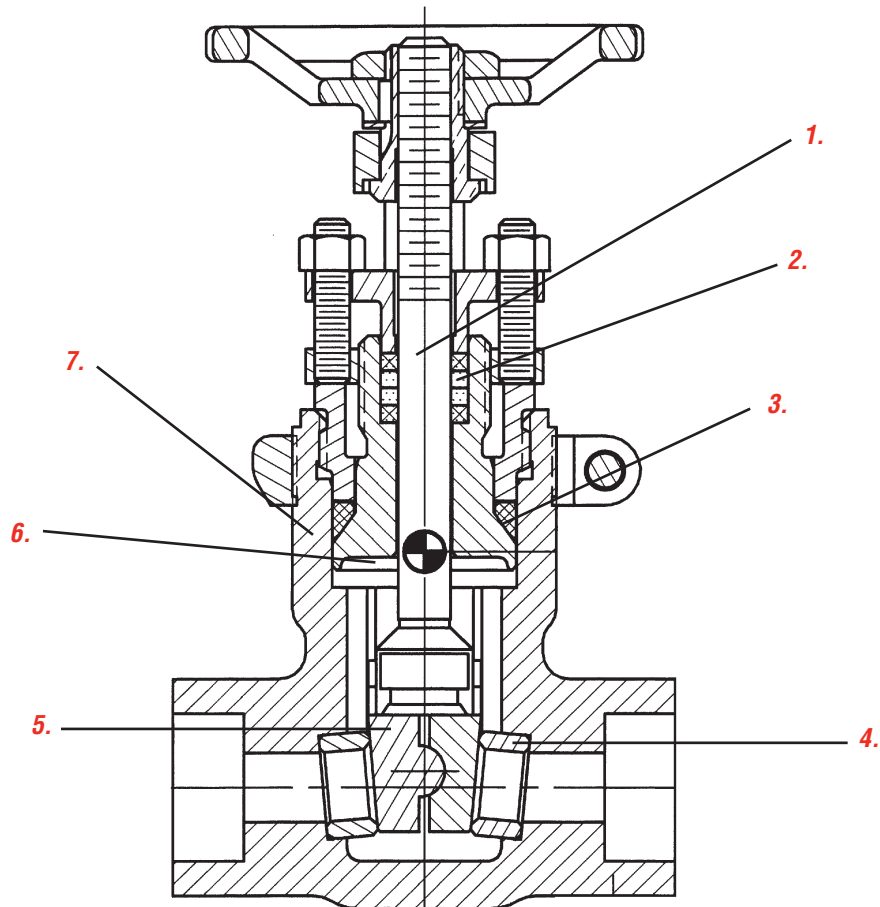

1. **Oversized stem** provides stronger disc-to-stem connection and reduces packing wear through increased stiffness.
2. **Graphite stem** packing provides better sealing and longer packing life.
3. **ADVanseal pressure** sealing system eliminates leakage, reduces maintenance and is more cost effective.

4. **Seat ring** is solid, hardened material (Stellite or non-Cobalt) and is fully shouldered and brazed in place.
5. **Two piece split wedge** is body guided, self aligning and solid, hardened material (Stellite or non-Cobalt).

6. **Machined backseat** provides additional packing protection.
7. **Investment cast body** produces a smooth flow transition, minimizes flow turbulence resulting in higher Cv's. Pressure seal bonnet eliminates leakage.

## Parts Specification List for Anchor/Darling 800 Series Gate Valves

### Standard Features

- Available body material  
SA216-WCB  
SA351-CF8M
- Investment cast for smooth flow
- Rising stem design

**Anchor/Darling 800 Series gate valves for nuclear service are normally furnished in Class 800. Other interpolated pressure classes are also available on application.**

Parts shown are not applicable to all 800 Series valves. Construction and materials for nuclear valves may vary depending upon customer design specifications. For a complete, accurate and itemized description of a particular valve, contact your local Flowserve valves sales representative.

Description	ASME/ASTM No.	ASME/ASTM No.
<b>Body</b>	SA216-WCB	SA351-CF8M
<b>Bonnet</b>	SA479-316	SA479-316
<b>Stem</b>	A564-630-1075	A564-630-1075
<b>Disc</b>	SA564-XM13-1100	SA564-XM13-1100
<b>Seat</b>	NOREM or Stellite	NOREM or Stellite
<b>End Rings</b>	Braided Graphite	Braided Graphite
<b>Packing Rings</b>	Grafoil	Grafoil
<b>Gland Retainer</b>	A564-630-1075	A564-630-1075
<b>Gland Adjusting Screw</b>	AISI-300	AISI-300
<b>Gland Flange</b>	A479-316	A479-316
<b>Yoke</b>	A351-CF8M	A351-CF8M
<b>Yoke Sleeve</b>	B21-C464-H02	B21-C464-H02
<b>Yoke Bolt</b>	A193-B7	A193-B7
<b>Yoke Bolt Nut</b>	A194-2H	A194-2H
<b>Handwheel</b>	A351-CF8M	A351-CF8M
<b>Handwheel Nut</b>	Carbon Steel	Carbon Steel
<b>Gasket Retainer</b>	SA564-630-1075	SA564-630-1075

## 800 Series Stop Valves, Class 800

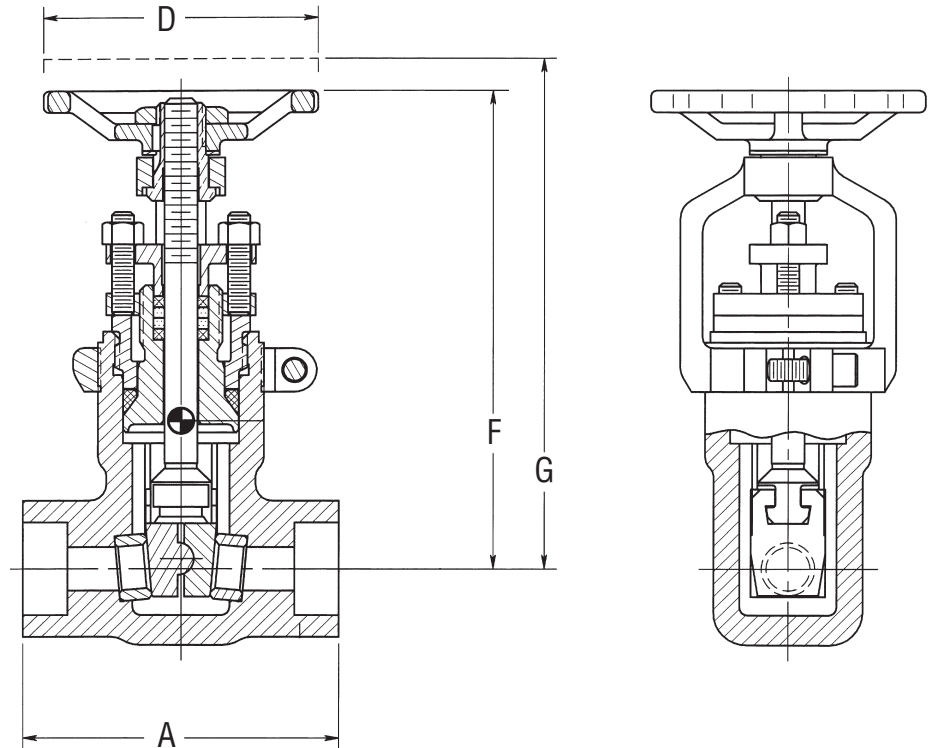

### Features

- Pressure Class 800 (Intermediate) (WCB, CF8M)
- Investment cast body
- Split wedge, body-guided disc
- Non-cobalt seat rings; standard
- Oversized non-rotating stem
- ADVanseal® pressure seal
- Graphite stem packing
- Machined backseat

### Pressure Class 800 (PN 130)

Fig. No.	Type	Ends	NPS (DN)
USW90S	Gate	Socket Weld	½ (15) thru 2 (50)
USW90U	Gate	Butt Weld	½ (15) thru 2 (50)

### Dimensions – Gate

Black numerals are in inches and pounds  
Colored numerals are in millimeters and kilograms

Figure No. USW90S/USW90U	NPS	½	¾	1	1½	2
	DN	15	20	25	40	50
A		3.3	3.6	4.5	4.8	5.1
		84	91	114	122	130
D		3.0	3.0	4.0	6.0	6.0
		76	76	102	152	152
F		5.7	5.7	6.9	8.5	9.8
		145	145	175	216	249
G		6.3	6.3	7.7	10.0	11.4
		160	160	196	254	290
Weight Approx (lbs.)		4.3	4.5	7.5	14.5	18.5
		2.0	2.0	3.4	6.6	8.4
Cv		15	28	50	120	175

Refer to page 37 for materials of construction.

Refer to pages 203 through 238 for the applicable pressure ratings.

## Features and Description of 1888 Series Double-Disc Gate Valve

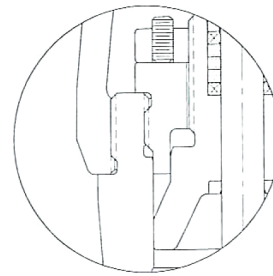
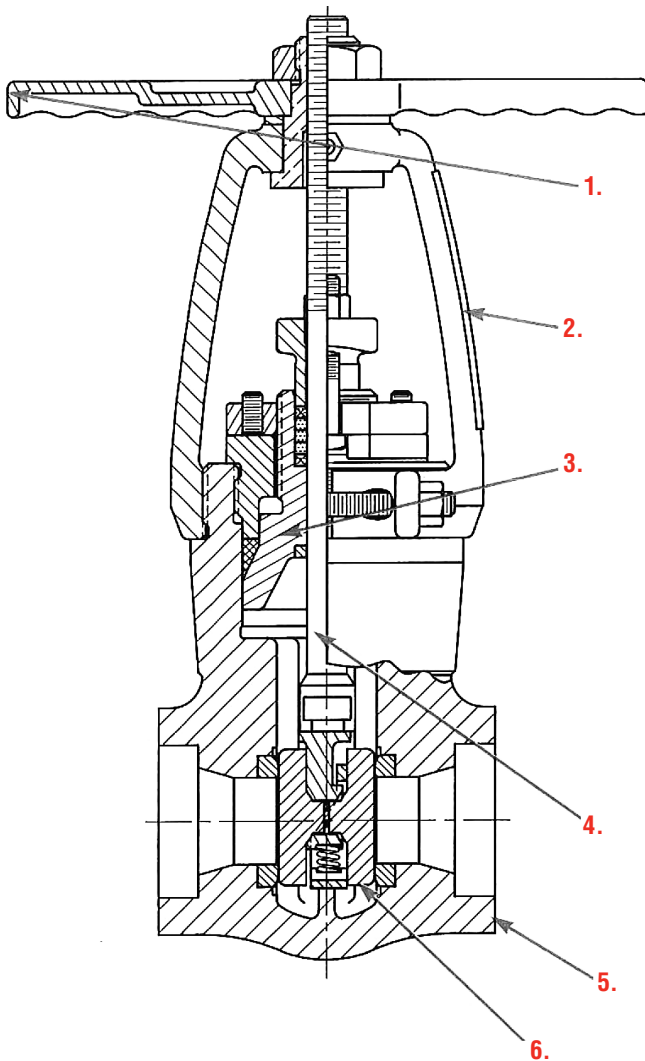

Pressure Seal Detail

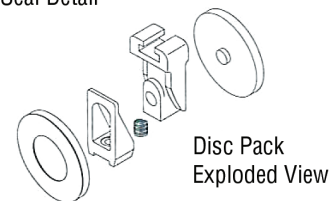

Disc Pack Exploded View

**1. Conversion from manual**

to motor-actuated valve does not require stem or bonnet change. Simply remove T-handle assembly and replace yoke.

**2. Stainless steel yoke** provides a non-corroding protector for the stem and gland area in the harshest environments

**3. Pressure seal bonnet** design allows easy access to valve internals while keeping radiation exposure to a minimum. A formed graphite gasket creates an extremely tight fit between the body and bonnet, while enhanced flexibility

and uniformity prohibit unacceptable body-to-bonnet leakage caused by minor marring in seal surfaces. Lower cost, easier reassembly, improved longevity and proven service in high-pressure nuclear and fossil generating-applications.

**4. T-Head design** stem provides positive backseat sealing.

**5. Rugged, low profile**, one-piece body with high Cv values and low center of gravity is designed to avoid distortion of internal parts due to piping loads and stresses.

**6. Discs** with uniform hardness and ample reserve margin for lapping or machining, resulting in greater integrity and longevity. Discs are flat; no critical angle to maintain or restore. Discs are trunion mounted and rotate during operation, resulting in even wear. Flat surfaces means no critical angle to maintain or restore.

## Parts Specification List for Anchor/Darling 1888 Series Double-Disc Gate Valves

### Standard Features

- Available body material  
SA216-WCB  
SA351-CF8M
- Investment cast for smooth flow
- Rising stem design

**Anchor/Darling 1888 Series gate valves for nuclear service are normally furnished in Class 1888. Other interpolated pressure classes are also available on application.**

Parts shown are not applicable to all 1888 Series valves. Construction and materials for nuclear valves may vary depending upon customer design specifications. For a complete, accurate and itemized description of a particular valve, contact your local Flowserve valves sales representative.

Description	ASME/ASTM No.	ASME/ASTM No.
Body	SA216-WCB	SA351-CF8M
Bonnet	SA105	SA182-F316
Stem	A564-630-1075	A564-630-1075
Disc	NOREM	NOREM
Body Seat	NOREM	NOREM
End Rings	Braided Graphite	Braided Graphite
Packing Rings	Grafoil	Grafoil
Gland	A351-CF8M	A351-CF8M
Gland Bolts	A193-B7	A564-630-1100
Yoke	A351-CF8M	A351-CF8M
Yoke Sleeve	B21-C464-H02	B21-C464-H02
Yoke Bolt	A574	A574
Yoke Bolt Nut	A194-2H	A194-2H
Handle	A351-CF8M	A351-CF8M
Stem Nut	AISI 316	AISI 316



## Series 1888 Stop Valves, Class 1888

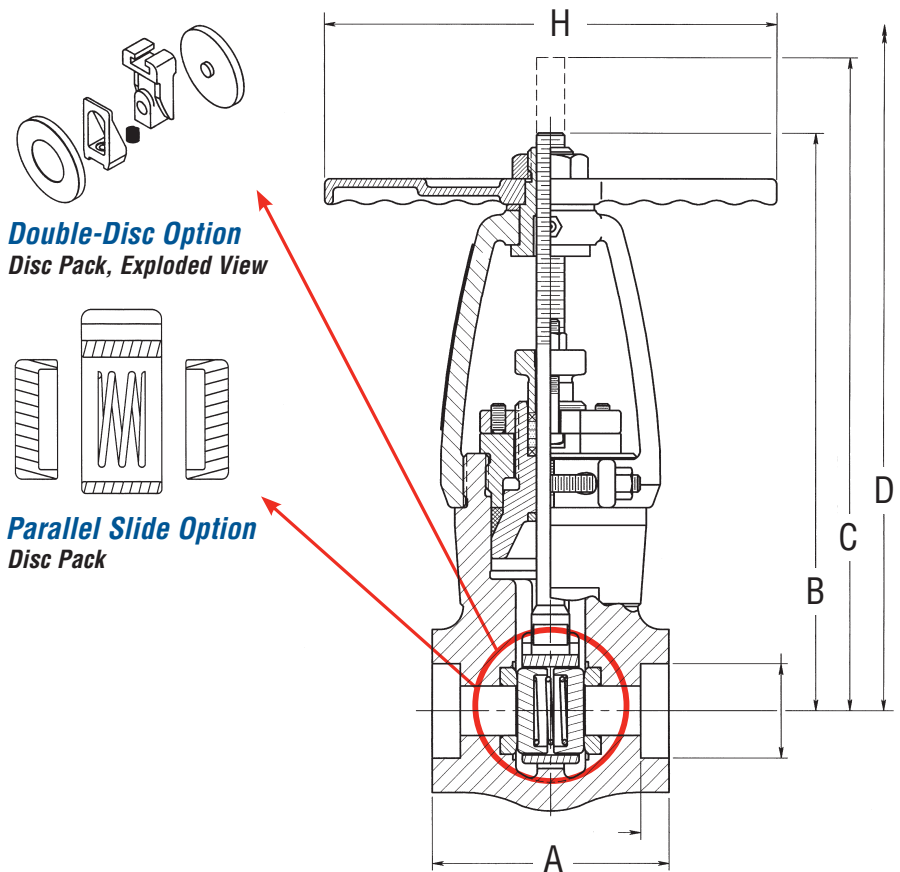

### Features

- Pressure Class 1888 (Intermediate) (WCB, CF8M)
- Ease of maintenance
- Uniform seat wear
- Rapid closure
- Critical surfaces hardened with non-cobalt materials
- Versatile actuator application
- No critical angles to maintain

### Pressure Class 1888 (PN 325)

Fig. No.	Type	Ends	NPS (DN)
TDD15S	Double-disc Gate	Socket Weld	¾ (20) thru 2 (50)
TDD15U	Double-disc Gate	Butt Weld	¾ (20) thru 2 (50)

### Dimensions – Gate

Black numerals are in inches and pounds  
Colored numerals are in millimeters and kilograms

Figure No. TDD15S/TDD15U	NPS	¾	1	1¼	1½	2
	DN	20	25	30	40	50
A		4.5	4.5	4.5	5.3	5.3
		114	114	114	135	135
B		12.7	12.7	12.7	12.9	12.9
		323	323	323	328	328
C		14.1	14.1	14.1	14.8	14.8
		358	358	358	376	376
H		10.0	10.0	10.0	10.0	10.0
		254	254	254	254	254
Weight Approx (lbs.)		27	27	27	36	36
		12.2	12.2	12.2	16.3	16.3
Cv		27	51	35	135	82

Refer to page 40 for materials of construction.  
Refer to pages 203 through 238 for the applicable pressure ratings.

## *Features and Description of Anchor/Darling Double-Disc Gate Valves*

- Uniform Seat Wear
- Low-Pressure Sealing
- Between-Seat Sealing
- Reliable Operation
- Versatile Actuator Application
- Critical Surfaces Hardfaced for Long Wear
- Rapid Closure
- Ease of Maintenance

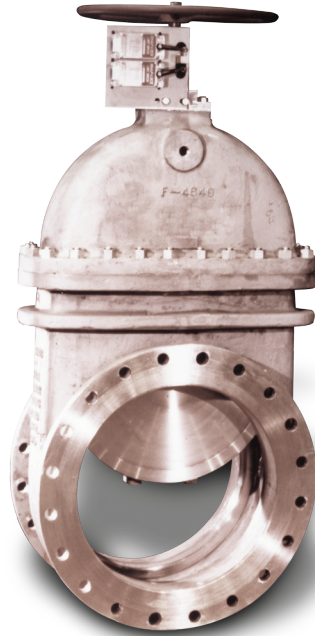

### *Reliable Under the Toughest Conditions*

Flowserve Anchor/Darling double-disc gate valves have been designed to provide reliable operation under the most severe service conditions.

This unique design will provide reliable operation when subjected to large pipe

nozzle loadings, rapid closure and repeated cycling. Extreme temperatures, gross thermal transients, high and low differential pressures, dirty and dual phase fluids have been considered in the development of the double-disc gate valve design.

Flowserve regularly supplies valves from ½" to 54" in diameter and 150 to 4500 psi pressure ratings in carbon steel and a wide range of special alloys. Seating surfaces are normally Stellite but other materials can be supplied depending on the application.

## Parts Specification List for Anchor/Darling Double-Disc Gate Valves

This is not a complete list. Construction and materials will vary between sizes and pressure classes and may be changed without notice. For a complete, accurate and itemized description of a particular valve, contact your Flowserve valves sales representative.

Description	ASME No.	ASME No.	ASME No.
Body/Bonnet*	SA-216 Grade WCB	SA-351 Grade CF8	SA-351 Grade CF8M
Discs	SA-105	SA-182 Grade F304	SA-182 Grade F316
Stem	A-582 Grade 416T	A-564 Grade 630-1075	A-564 Grade 630-1075
Pressure Seal Gasket**	Composite Pressure Seal Gasket.		
Bonnet Studs	A-193 Grade B7	A-193 Grade B7	A-193 Grade B7
Bonnet Nuts	A-194 Grade 2H	A-194 Grade 2H	A-194 Grade 2H
Gland	A-582 Grade 416T	A-479 Grade 304	A-479 Grade 304
Gland Studs	A-193 Grade B7	A-193 Grade B7	A-193 Grade B7
Gland Nuts	A-194 Grade 2H	A-194 Grade 2H	A-194 Grade 2H
Yoke	A-216 Grade WCB	A-216 Grade WCB	A-216 Grade WCB
Yoke Lock Ring	A-515 Grade 70	A-515 Grade 70	A-515 Grade 70
Yoke Lock Ring Studs	A-193 Grade B7	A-193 Grade B7	A-193 Grade B7
Yoke Lock Ring Nuts	A-194 Grade 2H	A-194 Grade 2H	A-194 Grade 2H
Handwheel	A-53 Class SB	A-53 Class SB	A-53 Class SB

## Double-Disc Stop Valves, Class 150

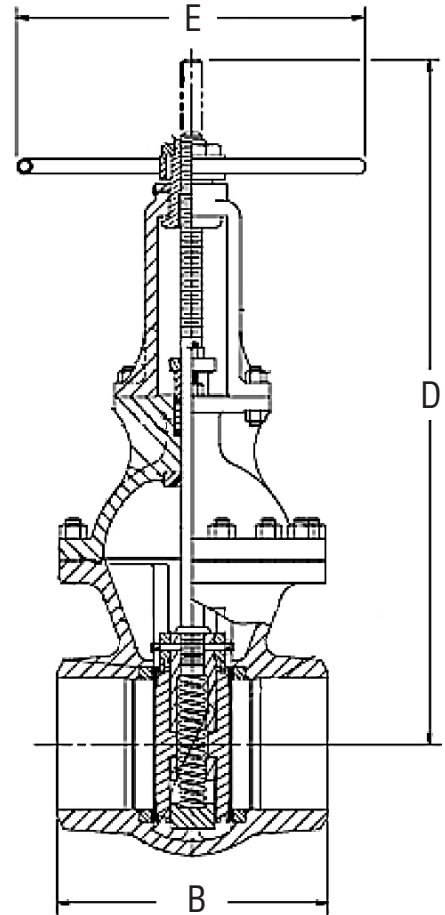

### Features

- Carbon, stainless or special alloys
- Bolted bonnet
- Available Stellite seat, disc and backseat
- Seat-guided disc
- Various combinations of seat and stem material
- Uniform distribution of sealing pressure

### Pressure Class 150 (PN 25)

Fig. No.	Type	Ends	NPS (DN)
BDD10U	Double-disc Gate	Butt Weld	2½ (65) thru 24 (600)
BDD10C	Double-disc Gate	Flanged	2½ (65) thru 24 (600)

### Dimensions – Double-Disc

Black numerals are in inches and pounds  
Colored numerals are in millimeters and kilograms

Figure No.	NPS	2½	3	4	6	8	10	12	14	16	18	20	24
<b>BDD10U/BDD10C</b>	<b>DN</b>	<b>65</b>	<b>80</b>	<b>100</b>	<b>150</b>	<b>200</b>	<b>250</b>	<b>300</b>	<b>350</b>	<b>400</b>	<b>450</b>	<b>500</b>	<b>600</b>
B		9.5	11.1	12.0	15.9	16.5	18.0	19.8	22.5	24.0	26.0	28.0	32.0
		241	282	305	404	419	457	503	572	610	660	711	813
D		23.0	25.0	31.0	41.0	46.0	54.0	63.0	67.0	74.0	81.0	90.0	104.0
		584	635	787	1,041	1,168	1,372	1,600	1,702	1,880	2,057	2,286	2,642
E		8.0	10.0	10.0	14.0	20.0	12.0	12.0	12.0	12.0	18.0	18.0	18.0
		203	254	254	356	508	305	305	305	305	457	457	457
Weight Approx (lbs.)		100	195	300	450	665	895	975	1350	1640	1930	2350	2985
		45.4	88.4	136.1	204.1	301.6	406	442.3	612.4	743.9	875.4	1,066	1,354
Cv		375	550	1025	2425	4500	7150	10,425	12,925	17,375	22,450	28,225	41,725

Refer to page 43 for materials of construction.

Refer to pages 203 through 238 for the applicable pressure ratings.

## Double-Disc Stop Valves, Class 300

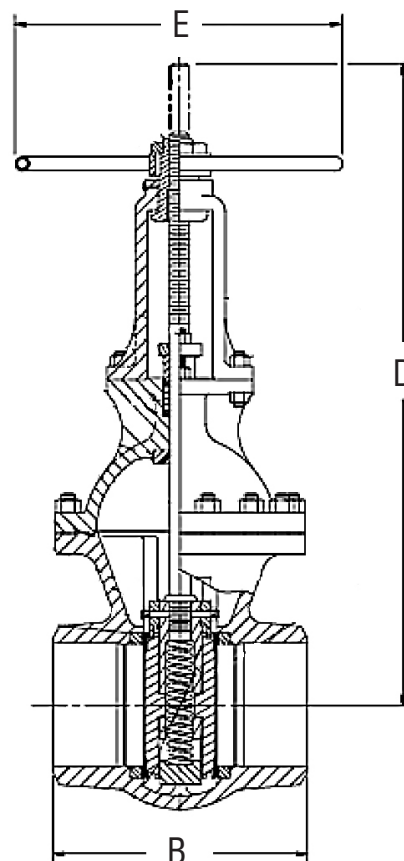

### Standard Features

- Carbon, stainless or special alloys
- Bolted bonnet
- Available Stellite seat, disc and backseat
- Seat-guided disc
- Various combinations of seat and stem material
- Uniform distribution of sealing pressure

### Pressure Class 300 (PN 50)

Fig. No.	Type	Ends	NPS (DN)
CDD10U	Double-disc Gate	Butt Weld	2½ (65) thru 24 (600)
CDD10C	Double-disc Gate	Flanged	2½ (65) thru 24 (600)

### Dimensions – Double-Disc

Black numerals are in inches and pounds  
Colored numerals are in millimeters and kilograms

Figure No. CDD10U/CDD10C	NPS	2½	3	4	6	8	10	12	14	16	18	20	24
	DN	65	80	100	150	200	250	300	350	400	450	500	600
B		9.5	11.1	12	15.9	16.5	18	19.8	30	33	36	39	45
		241	282	305	404	419	457	503	762	838	914	991	1,143
D		24	26	32	41	51	58	66	70	76	83	94	105
		610	660	813	1,041	1,295	1,473	1,676	1,778	1,930	2,108	2,388	2,667
E		8	10	12	20	12	12	12	12	12	18	18	18
		203	254	305	508	305	305	305	305	305	457	457	457
Weight Approx (lbs.)		100	195	300	450	800	1,055	1,260	1,550	2,150	2,890	3,350	5,580
		45.4	88.5	136.1	204.1	362.9	478.5	571.5	703.1	975.2	1,310.9	1,519.6	2,531.1
Cv		375	550	1,025	2,425	4,500	7,150	10,425	12,925	17,375	21,800	27,500	40,825

Refer to page 43 for materials of construction.

Refer to pages 203 through 238 for the applicable pressure ratings.

## Double-Disc Stop Valves, Class 600

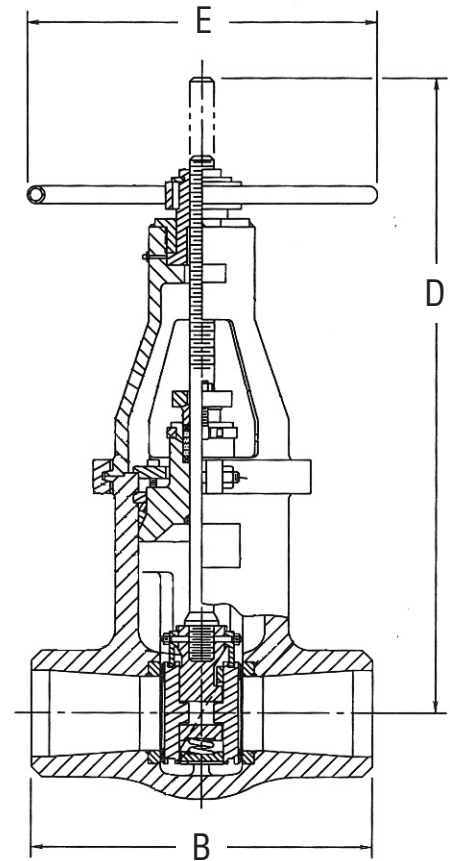

### Standard Features

- Carbon, stainless or special alloys
- Bolted bonnet or pressure seal
- Available Stellite seat, disc and backseat
- Seat-guided disc
- Various combinations of seat and stem material
- Uniform distribution of sealing pressure

### Pressure Class 600 (PN 110)

Fig. No.	Bonnet	Type	Ends	NPS (DN)
EDD10U	Bolted Bonnet	Double-disc Gate	Butt Weld	2½ (65) thru 24 (600)
EDD10C	Bolted Bonnet	Double-disc Gate	Flanged	2½ (65) thru 24 (600)
EDD15U	Pressure Seal	Double-disc Gate	Butt Weld	2½ (65) thru 24 (600)
EDD15C	Pressure Seal	Double-disc Gate	Flanged	2½ (65) thru 24 (600)

### Dimensions – Double-Disc

Black numerals are in inches and pounds  
Colored numerals are in millimeters and kilograms

Figure No. EDD10U/EDD10C, EDD15U/EDD15C	NPS	2½	3	4	6	8	10	12	14	16	18	20	24
	DN	65	80	100	150	200	250	300	350	400	450	500	600
B		8.5	10	12	18	23	28	32	35	39	43	47	55
		216	254	305	457	584	711	813	889	991	1,092	1,194	1,397
D		22	27	33	42	51	57	68	72	79	87	99	111
		559	686	838	1,067	1,295	1,448	1,729	1,829	2,007	2,210	2,515	2,819
E		10	12	14	20	12	12	12	12	18	18	18	24
		245	305	356	508	305	305	305	305	457	457	457	610
Weight Approx (lbs.)		85	140	225	450	940	1,185	1,575	2,160	2,795	3,525	5,575	7,750
		38.6	63.5	102.0	204.1	426.4	537.5	714.4	979.8	1,267.8	1,599.0	2,528.8	3,515.4
Cv		375	550	1,025	2,375	4,225	6,625	9,850	12,025	15,900	20,100	24,900	36,525

Refer to page 43 for materials of construction.

Refer to pages 203 through 238 for the applicable pressure ratings.

## Double-Disc Stop Valves, Class 900

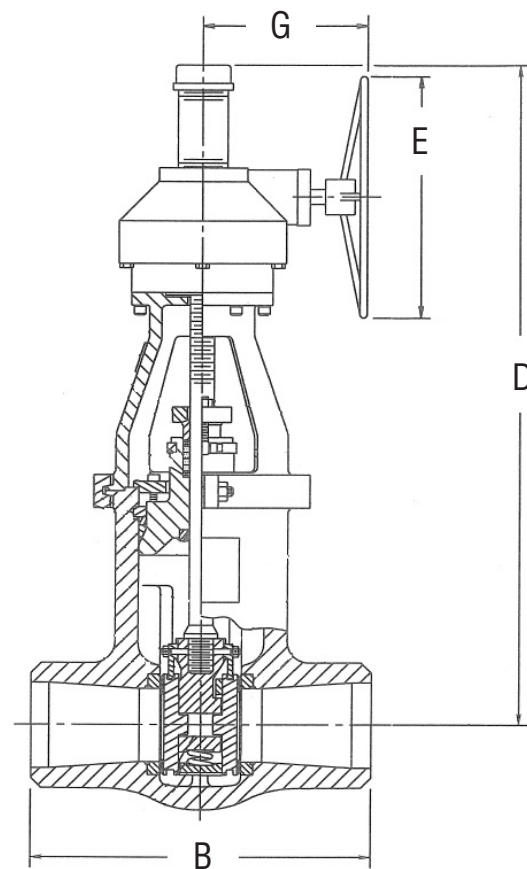

### Standard Features

- Carbon, stainless or special alloys
- Pressure seal
- Available Stellite seat, disc and backseat
- Seat-guided disc
- Various combinations of seat and stem material
- Uniform distribution of sealing pressure

### Pressure Class 900 (PN 150)

Fig. No.	Type	Ends	NPS (DN)
FDD15U	Double-disc Gate	Butt Weld	2½ (65) thru 24 (600)
FDD15C	Double-disc Gate	Flanged	2½ (65) thru 24 (600)

### Dimensions – Double-Disc

Black numerals are in inches and pounds  
Colored numerals are in millimeters and kilograms

Figure No. FDD15U/FDD15C	NPS	2½	3	4	6	8	10	12	14	16	18	20	24
	DN	65	80	100	150	200	250	300	350	400	450	500	600
B		10	12	14	20	26	31	36	39	43	48	50	59
		254	305	356	508	660	787	914	991	1,092	1,219	1,270	1,499
D		26	28	33	43	52	61	67	73	84	91	101	115
		660	711	838	1,092	1,321	1,549	1,702	1,854	2,134	2,311	2,565	2,921
E		12	14	16	12	12	12	12	18	18	18	18	24
		305	356	406	305	305	305	305	457	457	457	457	610
Weight Approx (lbs.)		130	175	260	690	1,065	1,375	2,085	2,560	3,335	4,650	6,265	9,800
		59	79.4	117.9	313	492.1	623.7	945.8	1,161	1,513	2,109	2,842	4,445
Cv		300	500	950	2,175	3,825	6,125	8,850	10,875	14,325	18,300	22,875	33,275

Refer to page 43 for materials of construction.

Refer to pages 203 through 238 for the applicable pressure ratings.

## Double-Disc Stop Valves, Class 1500

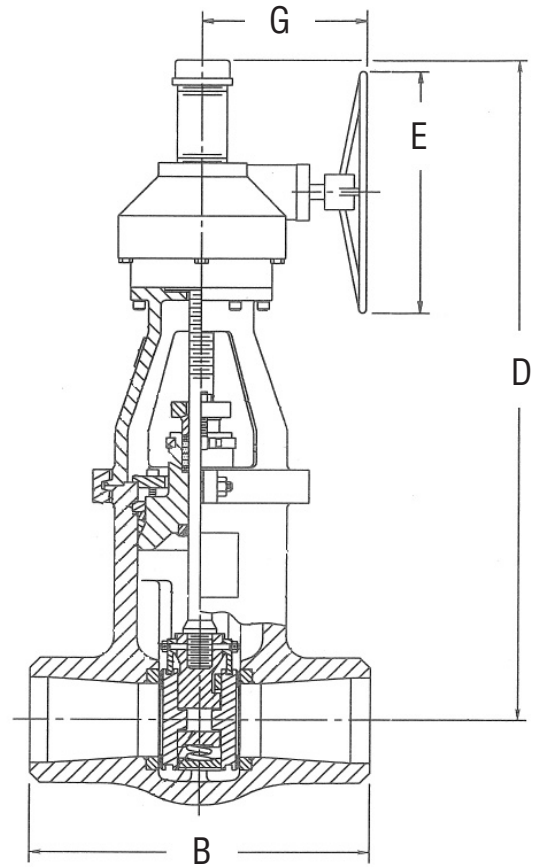

### Standard Features

- Carbon, stainless or special alloys
- Pressure seal
- Available Stellite seat, disc and backseat
- Seat-guided disc
- Various combinations of seat and stem material
- Uniform distribution of sealing pressure

### Pressure Class 1500 (PN 260)

Fig. No.	Type	Ends	NPS (DN)
GDD15U	Double-disc Gate	Butt Weld	2½ (65) thru 24 (600)
GDD15C	Double-disc Gate	Flanged	2½ (65) thru 24 (600)

### Dimensions – Double-Disc

Black numerals are in inches and pounds  
Colored numerals are in millimeters and kilograms

Figure No. GDD15U/GDD15C	NPS	2½	3	4	6	8	10	12	14	16	18	20	24
	DN	65	80	100	150	200	250	300	350	400	450	500	600
B		10	12	16	22	28	34	39	42	47	53	58	68
		254	305	406	559	711	864	991	1,067	1,194	1,346	1,473	1,727
D		27	28	36	44	52	61	69	74	91	92	104	118
		686	711	914	1,118	1,321	1,549	1,753	1,880	2,311	2,337	2,642	2,997
E		12	14	12	12	12	12	18	18	18	18	24	24
		305	356	305	305	305	305	457	457	457	457	610	610
Weight Approx (lbs.)		130	295	440	760	1,145	2,580	3,740	5,240	6,750	8,350	9,750	13,550
		58.9	133.8	199.6	344.7	519.4	1,170	1,696	2,377	3,062	3,788	4,423	6,146
Cv		300	450	800	1,875	3,275	5,250	7,525	9,175	12,150	15,500	19,600	28,775

Refer to page 43 for materials of construction.

Refer to pages 203 through 238 for the applicable pressure ratings.



## Features and Description of Flowserve Anchor/Darling Flex-Wedge Gate Valves



Flowserve has been supplying high-quality gate valves to the electric power and process industries throughout the world for over 90 years. Years of engineering research, combined with extensive operating experience, led to the development of the Flowserve Anchor/Darling Flex-Wedge design. The uniform section wedge offered today is the

result of improvements to the solid, I-section and slotted configurations that have been supplied over the years. It is our continued commitment to incorporate the latest proven technology that has gained the Anchor/Darling Flex-Wedge Valve the reputation for superior reliability.

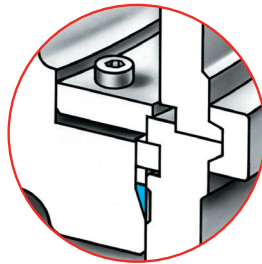

**Pressure Seal Design**

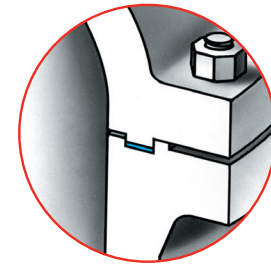

**Bolted Bonnet Design**

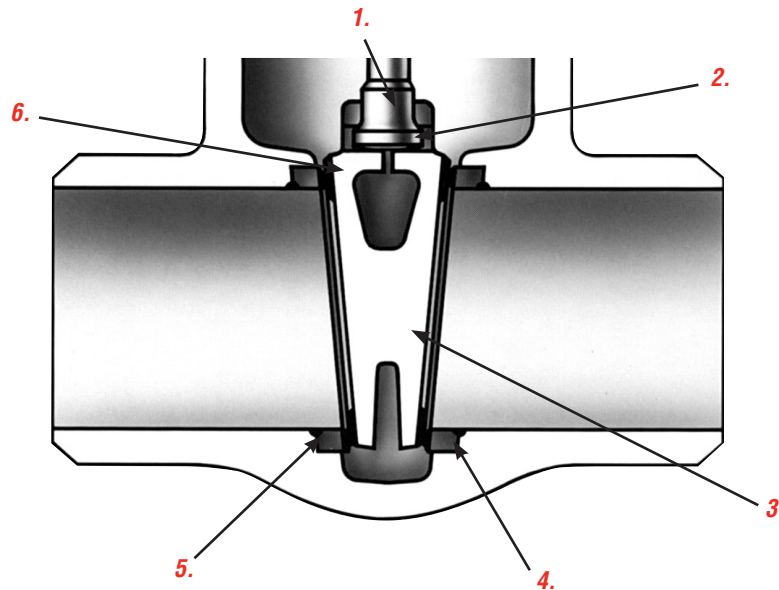

**1. Tight backseat sealing** is achieved with less seating force because of the differential in mating angles between the stem shoulder and the hard-faced bonnet backseat.

**2. T-head connection** prevents transfer of side thrust from stem to wedge.

**3. Minimum center core** ensures sufficient seating thrust, yet permits sealing surfaces to flex and seal tightly.

**4. A crowned sealing surface** reduces contact area and ensures sufficient unit loading for a tight seal with minimal force.

**5. Seat rings** are seal welded to minimize distortion from body stress while retaining ease of replacement.

**6. The uniform thickness** of the flexure area at any radial point ensures consistent seating forces over the total sealing area.



## Parts Specification List for Anchor/Darling Flex-Wedge Gate Valves

This is not a complete list. Construction and materials will vary between sizes and pressure classes and may be changed without notice. For a complete, accurate and itemized description of a particular valve, contact your Flowserve valves sales representative.

Description	ASME No.	ASME No.	ASME No.
Body/Bonnet	SA-216 Grade WCB	SA-351 Grade CF8	SA-351 Grade CF8M
Gate 2½-6	SA-216 Grade WCB	SA-351 Grade CF8M	SA-351 Grade CF8M
Stem	A-314 Grade 410T	A-564 Grade 630-1075	A-564 Grade 630-1075
Pressure Seal Gasket	Composite Pressure Seal Gasket.		
Bonnet Retainer	A-515 Grade 70	A-515 Grade 70	A-515 Grade 70
Bonnet Retainer Studs	SA-193 Grade B7	SA-193 Grade B7	SA-193 Grade B7
Bonnet Retainer Nuts	A-194 Grade 2H	A-194 Grade 2H	A-194 Grade 2H
Gland	A-582 Grade 416T	A-479 Grade 304	A-479 Grade 304
Gland Studs	A-193 Grade B7	A-193 Grade B7	A-193 Grade B7
Gland Nuts	A-194 Grade 2H	A-194 Grade 2H	A-194 Grade 2H
Yoke	A-216 Grade WCB	A-216 Grade WCB	A-216 Grade WCB
Yoke Lock Ring	A-516 Grade 70	A-516 Grade 70	A-516 Grade 70
Yoke Lock Ring Studs	A-193 Grade B7	A-193 Grade B7	A-193 Grade B7
Yoke Lock Ring Nuts	A-194 Grade 2H	A-194 Grade 2H	A-194 Grade 2H
Handwheel	A-53 Class SB	A-53 Class SB	A-53 Class SB

## Flex-Wedge Stop Valves, Class 150

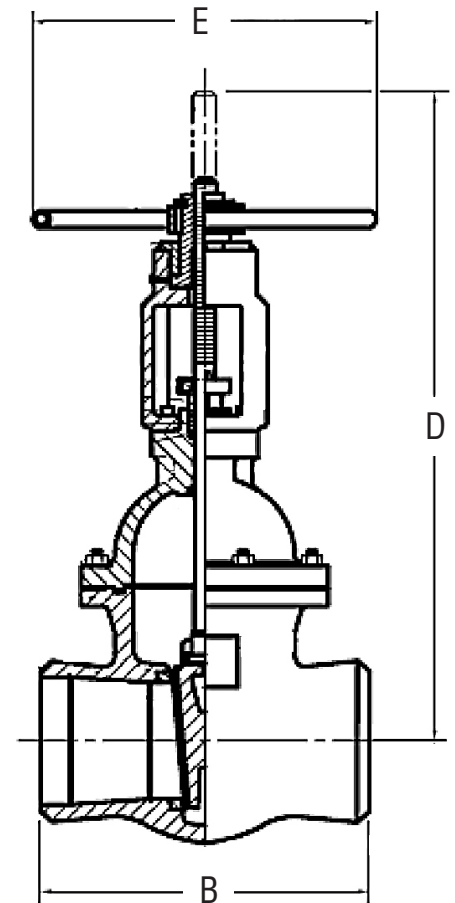

### Features

- Carbon, stainless or special alloys
- Bolted bonnet
- Available Stellite seat, disc and backseat
- Seat-guided disc
- Various combinations of seat and stem material
- Uniform distribution of sealing pressure

### Pressure Class 150 (PN 25)

Fig. No.	Type	Ends	NPS (DN)
BGT01U	Gate	Butt Weld	2½ (65) thru 24 (600)
BGT01C	Gate	Flanged	2½ (65) thru 24 (600)

### Dimensions – Flex Wedge, Butt Weld end only. Flanged dimensions available on request.

Black numerals are in inches and pounds  
Colored numerals are in millimeters and kilograms

Figure No.	NPS	2½	3	4	6	8	10	12	14	16	18	20	24
<b>BGT01U/BGT01C</b>	<b>DN</b>	<b>65</b>	<b>80</b>	<b>100</b>	<b>150</b>	<b>200</b>	<b>250</b>	<b>300</b>	<b>350</b>	<b>400</b>	<b>450</b>	<b>500</b>	<b>600</b>
B		9.5	11.1	12.0	15.9	16.5	18.0	19.8	22.5	24.0	26.0	28.0	32.0
		241	282	305	404	419	457	503	572	610	660	711	813
D		23.0	25.0	29.0	35.0	46.0	50.0	61.0	64.0	70.0	78.0	87.0	98.0
		584	635	737	889	1,168	1,270	1,549	1,626	1,778	1,981	2,210	2,489
E		12.0	12.0	12.0	12.0	12.0	12.0	18.0	12.0	12.0	12.0	12.0	18.0
		305	305	305	305	305	305	457	305	305	305	305	457
Weight Approx (lbs.)		80	125	175	265	440	600	840	1100	1450	1835	2400	3150
		36.2	56.7	79.4	120.2	199.6	272.1	381	499	657.7	832.3	1,088.6	1,428.8
Cv		375	550	1025	2425	4500	7150	10,425	12,925	17,375	22,450	28,225	41,725

Refer to page 50 for materials of construction.

Refer to pages 203 through 238 for the applicable pressure ratings.

## Flex-Wedge Stop Valves, Class 300

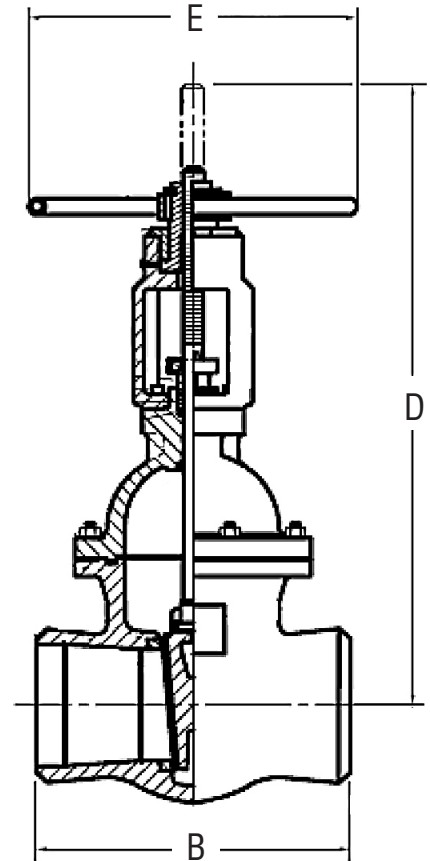

### Standard Features

- Carbon, stainless or special alloys
- Bolted bonnet
- Available Stellite seat, disc and backseat
- Seat-guided disc
- Various combinations of seat and stem material
- Uniform distribution of sealing pressure

### Pressure Class 300 (PN 50)

Fig. No.	Type	Ends	NPS (DN)
CGT01U	Flex Wedge Gate	Butt Weld	2½ (65) thru 24 (600)
CGT01C	Flex Wedge Gate	Flanged	2½ (65) thru 24 (600)

### Dimensions – Flex Wedge

Black numerals are in inches and pounds  
Colored numerals are in millimeters and kilograms

Figure No. CGT01U/CGT01C	NPS	2-½	3	4	6	8	10	12	14	16	18	20	24
	DN	65	80	100	150	200	250	300	350	400	450	500	600
B		9.5	11.1	12	15.9	16.5	18	19.8	30	33	36	39	45
		241	282	305	404	419	437	503	762	838	914	991	1,143
D		23	25	29	40	47	54	62	66	76	83	90	103
		584	635	737	1,016	1,194	1,372	1,575	1,676	1,930	2,108	2,286	2,616
E		12	12	12	12	18	12	18	18	18	24	18	18
		305	305	305	305	457	305	457	457	457	610	457	457
Weight Approx (lbs.)		60	125	175	375	560	850	1,245	1,400	1,850	2,385	2,950	5,500
		27.2	56.7	79.4	170.1	254.0	385.6	564.7	635.0	839.2	1,081.8	1,338.1	2,494.8
Cv		375	550	1,025	2,425	4,500	7,150	10,425	12,925	17,375	21,800	27,500	40,825

Refer to page 50 for materials of construction.

Refer to pages 203 through 238 for the applicable pressure ratings.

## Flex-Wedge Stop Valves, Class 600

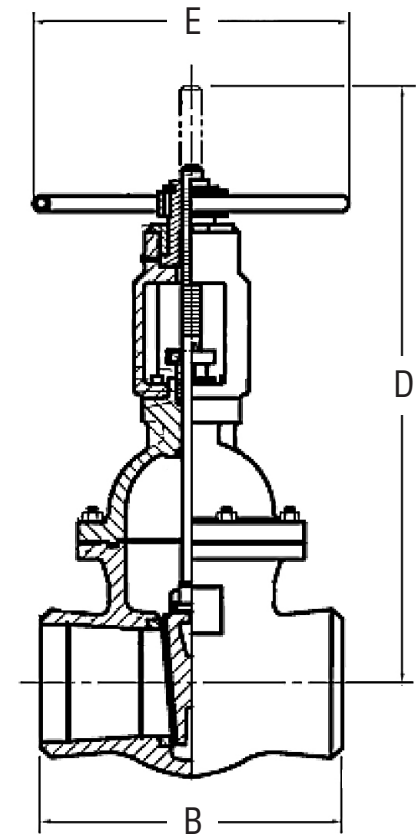

### Standard Features

- Carbon, stainless or special alloys
- Bolted bonnet or pressure seal
- Available Stellite seat, disc and backseat
- Seat-guided disc
- Various combinations of seat and stem material
- Uniform distribution of sealing pressure

### Pressure Class 600 (PN 110)

Fig. No.	Type	Ends	NPS (DN)
EGT01U	Bolted Bonnet Flex Wedge Gate	Butt Weld	2½ (65) thru 24 (600)
EGT01C	Bolted Bonnet Flex Wedge Gate	Flanged	2½ (65) thru 24 (600)
EGT05U	Pressure Seal Flex Wedge Gate	Butt Weld	2½ (65) thru 24 (600)
EGT05C	Pressure Seal Flex Wedge Gate	Flanged	2½ (65) thru 24 (600)

### Dimensions – Flex Wedge

Black numerals are in inches and pounds  
Colored numerals are in millimeters and kilograms

Figure No. EGT01U/EGT01C, EGT05U/EGT05C	NPS	2½	3	4	6	8	10	12	14	16	18	20	24
	DN	65	80	100	150	200	250	300	350	400	450	500	600
B		8.5	10	12	18	23	28	32	35	39	43	47	55
		216	254	305	457	584	711	813	889	991	1,092	1,194	1,399
D		21	29	31	42	47	57	65	69	77	83	98	110
		533	737	787	1,067	1,194	1,448	1,651	1,753	1,955	2,108	2,489	2,794
E		12	12	12	12	18	12	12	12	18	18	18	36
		305	305	305	305	457	305	305	305	457	457	457	914
Weight Approx (lbs.)		75	130	215	550	750	925	1,495	1,900	2,645	3,760	5,270	7,500
		34.0	59.0	97.0	249.5	340.2	420.6	678.1	861.8	1,199.8	1,705.5	2,390.5	3,402
Cv		375	550	1,025	2,375	4,225	6,625	9,850	12,025	15,900	20,100	24,900	36,525

Refer to page 50 for materials of construction.  
Refer to pages 203 through 238 for the applicable pressure ratings.

## Flex-Wedge Stop Valves, Class 900

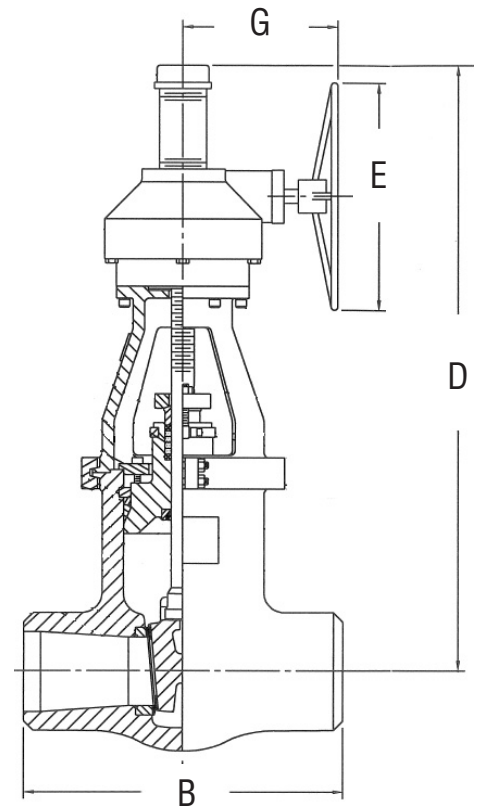

### Standard Features

- Carbon, stainless or special alloys
- Pressure seal available
- Available Stellite seat, disc and backseat
- Seat-guided disc
- Various combinations of seat and stem material
- Uniform distribution of sealing pressure

### Pressure Class 900 (PN 150)

Fig. No.	Type	Ends	NPS (DN)
FGT05U	Flex Wedge Gate	Butt Weld	2½ (65) thru 24 (600)
FGT05C	Flex Wedge Gate	Flanged	2½ (65) thru 24 (600)

### Dimensions – Flex Wedge

Black numerals are in inches and pounds  
Colored numerals are in millimeters and kilograms

Figure No. FGT05U/FGT05C	NPS	2½	3	4	6	8	10	12	14	16	18	20	24
	DN	65	80	100	150	200	250	300	350	400	450	500	600
B		10	12	14	20	26	31	36	39	43	48	50	59
		254	305	356	508	660	787	914	991	1,092	1,219	1,270	1,499
D		26	28	31	46	48	55	64	72	84	95	102	112
		635	711	787	1,168	1,219	1,397	1,626	1,829	2,134	2,413	2,591	2,845
E		12	12	18	12	18	18	18	12	18	12	18	12
		305	305	457	305	457	457	457	305	457	305	457	305
G		—	—	—	11	11	15	15	15	16	21	22	23
		—	—	—	279	279	381	381	381	406	533	559	584
Weight Approx (lbs.)		160	160	225	660	910	1,500	2,030	2,600	3,500	5,620	7,920	11,500
		72.6	72.6	102	299.4	412.8	680.4	920.8	1,270	1,588	2,549	3,593	5,262
Cv		300	500	950	2,175	3,825	6,125	8,850	10,875	14,325	18,300	22,875	33,275

Refer to page 50 for materials of construction.

Refer to pages 203 through 238 for the applicable pressure ratings.

## Flex-Wedge Stop Valves, Class 1500

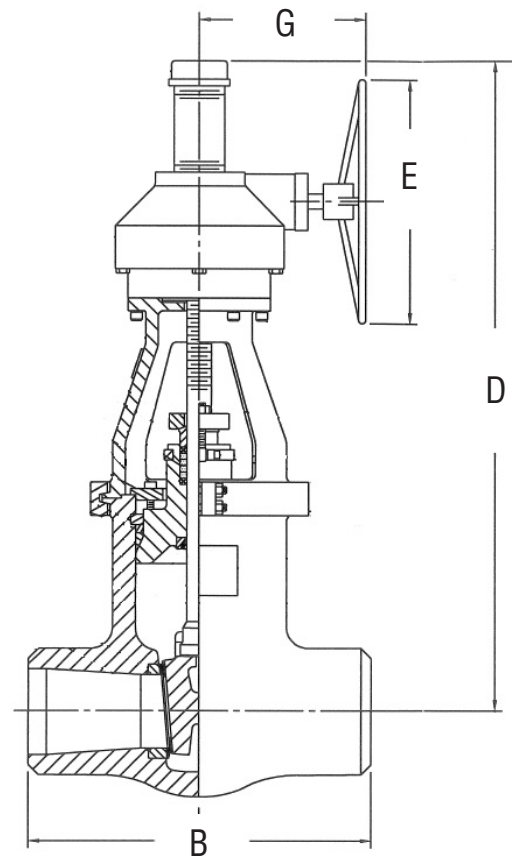

### Standard Features

- Carbon, stainless or special alloys
- Pressure seal
- Available Stellite seat, disc and backseat
- Seat-guided disc
- Various combinations of seat and stem material
- Uniform distribution of sealing pressure

### Pressure Class 1500 (PN 260)

Fig. No.	Type	Ends	NPS (DN)
GGT05U	Flex Wedge Gate	Butt Weld	2½ (65) thru 24 (600)
GGT05C	Flex Wedge Gate	Flanged	2½ (65) thru 24 (600)

### Dimensions – Flex Wedge

Black numerals are in inches and pounds  
Colored numerals are in millimeters and kilograms

Figure No. GGT05U/GGT05C	NPS	2½	3	4	6	8	10	12	14	16	18	20	24
	DN	65	80	100	150	200	250	300	350	400	450	500	600
B		10	12	16	22	28	34	39	42	47	53	58	68
		254	305	406	559	711	864	991	1,067	1,194	1,346	1,473	1,727
D		28	30	34	46	53	60	68	78	89	101	114	128
		711	762	864	1,168	1,346	1,524	1,727	1,981	2,261	2,565	2,896	3,251
E		12	12	12	18	18	12	18	12	12	12	18	18
		305	305	305	457	457	305	457	305	305	305	457	457
Weight Approx (lbs.)		250	290	410	760	1,420	1,920	3,350	4,200	5,860	7,850	9,200	15,250
		113.4	131.5	186.0	340.2	644.1	870.9	1,520	1,905	2,658	3,561	4,173	6,917
Cv		300	450	800	1,875	3,275	5,250	7,525	9,175	12,150	15,500	19,600	28,775

Refer to page 50 for materials of construction.

Refer to pages 203 through 238 for the applicable pressure ratings.

Page intentionally left blank



## **Edward Globe and Stop-Check Valves**

## Features and Description of Edward Bolted Bonnet Globe Valves

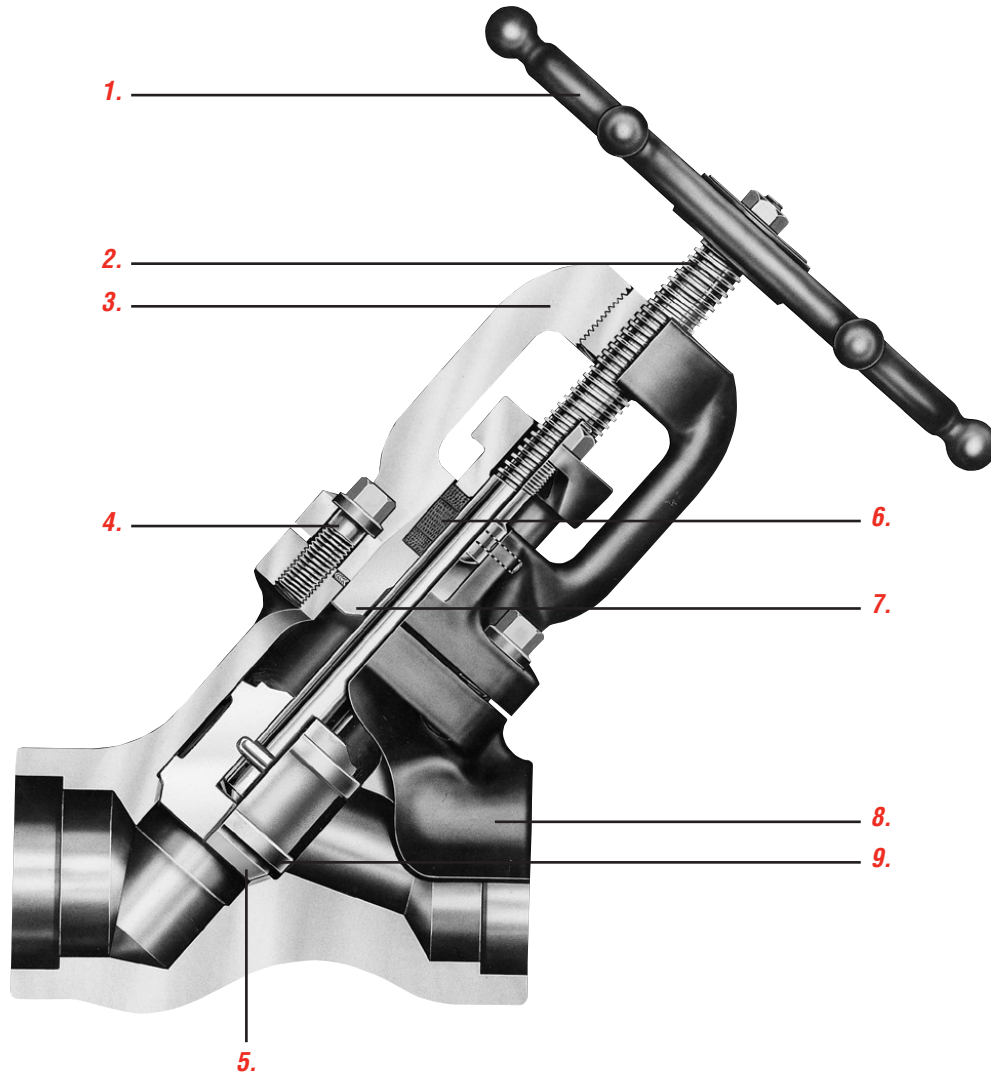

**1. Handwheel** is rugged and knobbed to provide sure grip even when wearing gloves.

**2. Stem** has ACME threads, is grounded to a fine finish and is hardened to resist wear.

**3. Yoke bushing** material has low coefficient of friction, which substantially reduces torque and stem wear and eliminates galling. Mechanical upset locks yoke bushing to yoke.

**4. Bolted bonnet** joint utilizes a spiral-wound gasket for positive sealing and four-bolt design for ease of assembly. Bonnet has pilot extension to ensure proper alignment and positive metal-to-metal stop to prevent over-compression of gasket.

**5. Integral hardsurfaced seat** provides positive shutoff and long seat life.

**6. Stem packing system** utilizes flexible graphite packing material with anti-extrusion rings for optimum sealability and life.

**7. Integral backseat** provides a secondary stem seal backup for positive shutoff and leak protection.

**8. Body** utilizes optimized flow passages to minimize flow direction changes and reduce pressure drop.

**9. Body-guided disc** utilizes anti-thrust rings to eliminate misalignment, galling and stem bending.

## Parts Specification List for Edward Bolted Bonnet Globe Valves

Edward bolted bonnet valves for nuclear service are available in Class 600 only. Refer to Forged Steel Catalog, EVENCT0001 for stop, stop-check and piston check valve dimensions (Class 800 dimensions apply to Nuclear Class 600 Valves).

This is not a complete list. Construction and materials will vary between sizes and pressure classes and may be changed without notice. For a complete, accurate and itemized description of a particular valve, contact your Flowserve Edward and Anchor/Darling valves sales representative.

Description	Bolted Bonnet
	ASME/ASTM No.
Body/Bonnet	SA-105 -
Disc*	AISI 615
Body Seat	Stellite 21
Stem	A-582 T-416
Capscrews	SA-193 Grade B-7
Gasket	Spiral Wound Non Asbestos
Packing	Flexible Graphite System
Gland	A-582 Grade 80 - 55 - 06
Yoke Bushing	B-150 C61900 or C6230100
Handwheel/Handle	Malleable or Ductile Iron
Stem Nut	Mild Steel Plated
Eye Bolt	A-582 T-416
Eye Bolt Nut	A-194 Grade 8
Eye Bolt Pin	AISI Grade 4140
Spring**	A-313 T-302

\* Check and stop-check valve discs are A565T-616

\*\* Check valves and stop-check valves

## Stop Valves, Class 600

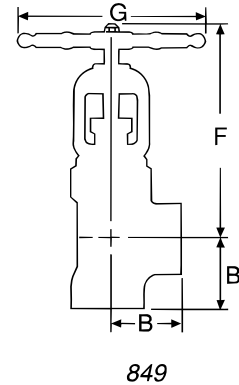
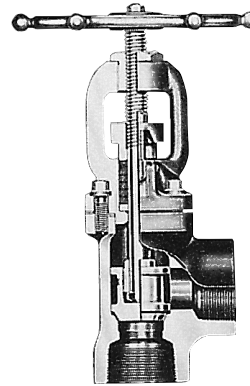
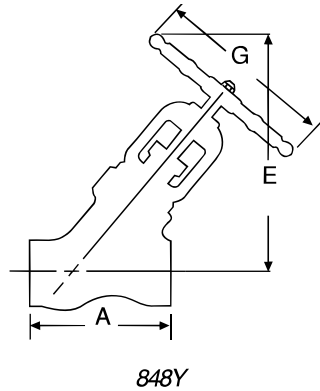

### Standard Features

- Bodies and bonnets are of forged steel (A105)
- Bolted bonnet, OS & Y
- Y pattern or angle design
- Body-guided hardened stainless steel disc
- Integral Stellite seat
- Integral backseat
- 13% chromium stainless steel stem

### Pressure Class 600 (PN 110)

Fig. No.	Type	Ends	NPS (DN)
848Y	Y Pattern	Socket Weld	¼ (8) thru 2 (50)
849Y	Angle	Socket Weld	

- Asbestos-free graphitic packing
- Asbestos-free spiral-wound bonnet gasket
- Knobbed handwheel

### Dimensions – Globe & Angle

Black numerals are in inches and pounds  
Colored numerals are in millimeters and kilograms

Figure No. 848/848Y, 849/849Y	NPS	¼	3/8	½	¾	1	1¼	1½	2
	DN	8	10	15	20	25	32	40	50
A - End to End, Globe		3	3	3	3.6	4.3	5.8	5.8	6.5
		76	76	76	91	109	147	147	165
B - Center to End, Angle		1.5	1.5	1.5	1.8	2	2.9	2.9	3.3
		38	38	38	46	51	74	74	84
E - Center to Top, Globe (Open)		6	6	6	6.8	7.6	10.9	10.9	12.1
		152	152	152	173	193	277	277	307
F - Center to Top, Angle (Open)		5.7	5.7	5.7	6.4	7.1	10.2	10.2	11
		145	145	145	163	180	259	259	279
G - Handwheel Diameter		3.8	3.8	3.8	4.3	4.8	7.1	7.1	8.5
		97	97	97	109	122	180	180	216
Weight, Globe		4	4	4	5.5	7.5	16	16	23
		1.8	1.8	1.8	2.5	3.4	7.2	7.2	10.4
Weight, Angle		4	4	4	5.5	7	17	17	24
		1.8	1.8	1.8	2.5	3.2	7.7	7.7	10.8

Refer to page 59 for materials of construction.  
Refer to pages 203 through 238 for the applicable pressure ratings.

## Stop-Check Valves, Class 600

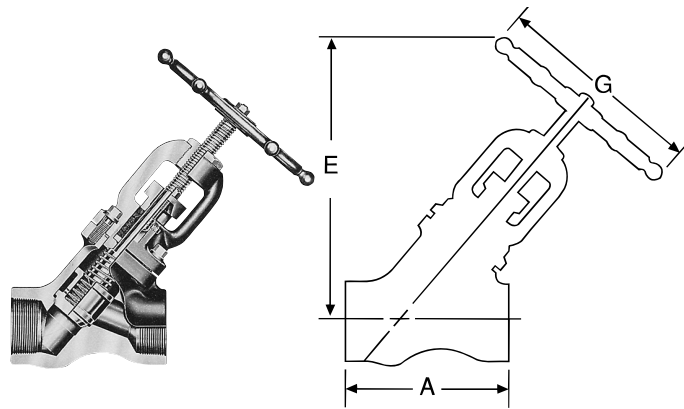

868

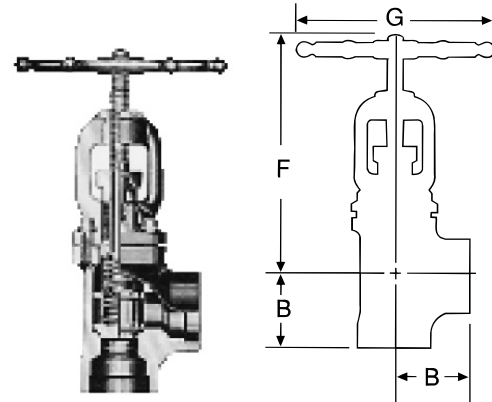

869Y

### Standard Features

- Bodies and bonnets are of forged steel (A105)
- Bolted bonnet, OS & Y
- Y pattern or angle design
- Body-guided hardened stainless steel disc
- Integral Stellite seat
- Integral backseat
- 13% chromium stainless steel stem
- Asbestos-free graphitic packing
- Asbestos-free spiral wound bonnet gasket
- Knobbed handwheel
- Stainless steel spring

### Pressure Class 600 (PN 110)

Fig. No.	Type	Ends	NPS (DN)
868Y	Y Pattern	Socket Weld	¼ (8) thru 2 (50)
869Y	Angle	Socket Weld	

### Dimensions – Globe & Angle

Black numerals are in inches and pounds  
Colored numerals are in millimeters and kilograms

Figure No. 868/868Y, 869/869Y	NPS	¼	3/8	½	¾	1	1¼	1½	2
	DN	8	10	15	20	25	32	40	50
A - End to End, Globe		3	3	3	3.6	4.3	5.8	5.8	6.5
		76	76	76	91	109	147	147	165
B - Center to End, Angle		1.5	1.5	1.5	1.8	2	2.9	2.9	3.3
		38	38	38	46	51	74	74	84
E - Center to Top, Globe (Open)		6	6	6	6.8	7.6	10.9	10.9	12.1
		152	152	152	173	193	277	277	307
F - Center to Top, Angle (Open)		5.7	5.7	5.7	6.4	7.1	10.2	10.2	11
		145	145	145	163	180	259	259	279
G - Handwheel Diameter		3.8	3.8	3.8	4.3	4.8	7.1	7.1	8.5
		97	97	97	109	122	180	180	216
Weight, Globe		4	4	4	5.5	7.5	16	16	23
		1.8	1.8	1.8	2.5	3.4	7.2	7.2	10.4
Weight, Angle		4	4	4	5.5	7	17	17	24
		1.8	1.8	1.8	2.5	3.2	7.7	7.7	10.8

Refer to page 59 for materials of construction.

Refer to pages 203 through 238 for the applicable pressure ratings.

## Features and Description of Edward Univalve® Globe Valves

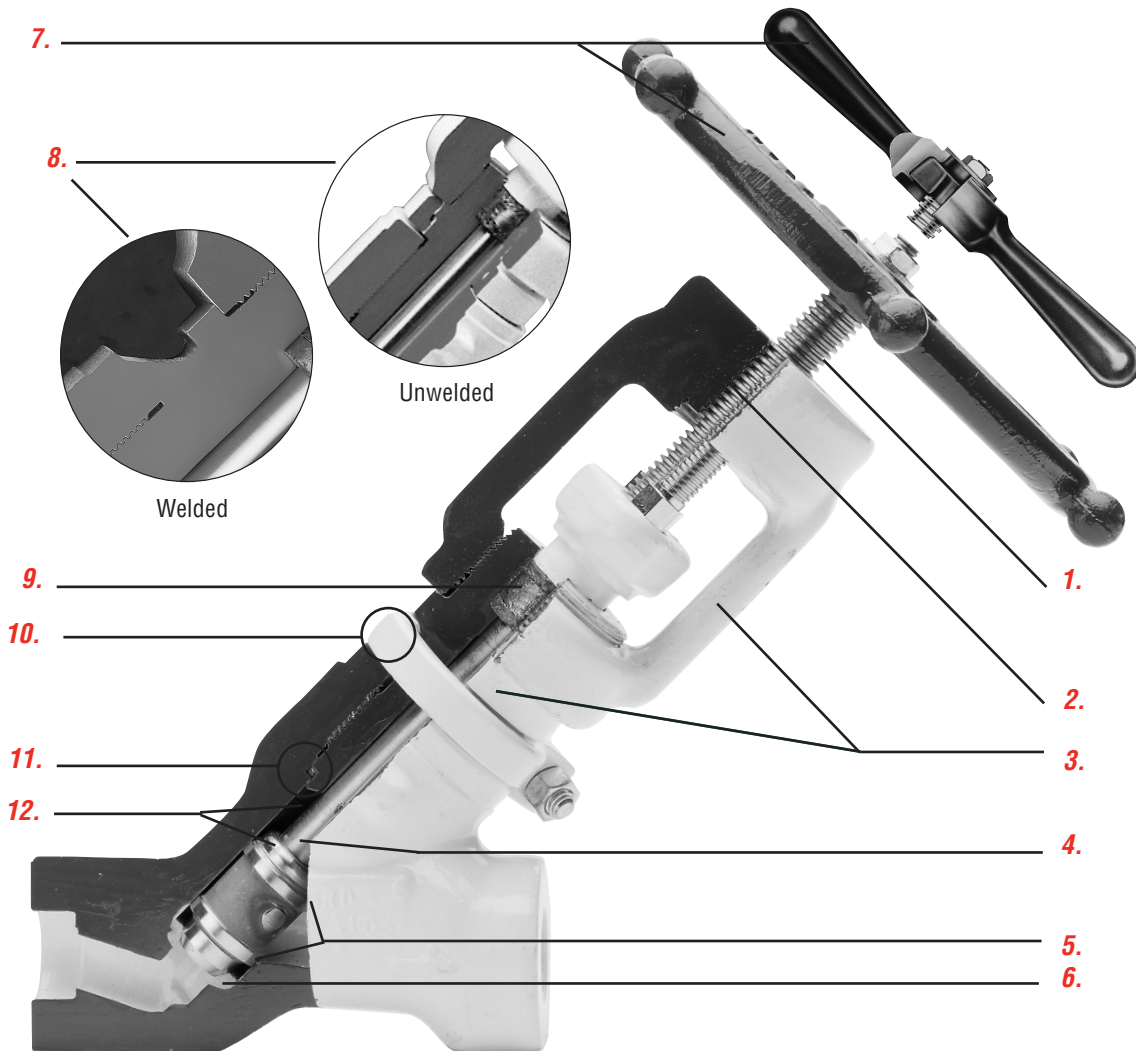

1. **Stem** has ACME threads, is ground to a fine finish and is hardened to resist wear.
2. **Yoke bushing** material has low coefficient of friction, which substantially reduces torque and stem wear and eliminates galling. Mechanical upset locks yoke bushing to yoke.
3. **Yoke-bonnet assembly** is two piece to facilitate disassembly for faster in-line internal repairs.
4. **Inclined stem** construction and optimum flow shape minimize flow direction changes and reduce pressure drop.
5. **Body-guided disc** utilizes anti-thrust rings to eliminate misalignment, galling and stem bending.
6. **Integral hardsurfaced seat** provides positive shutoff and long seat life.
7. **Handwheel** on smaller size valves is rugged and knobbed to provide sure grip even when wearing gloves. Impactor handle or handwheel on larger, higher pressure valves provides many times the closing force of an ordinary handwheel for positive seating.
8. **Threaded bonnet** has ACME threads for resistance to galling and ease of disassembly. Unwelded models utilize a graphitic gasket for dependable sealing. Welded models employ a fillet weld (canopy weld on stainless steel valves) for absolute protection from body-bonnet leakage.
9. **Stem packing system** utilizes flexible graphite packing material with carbon fiber anti-extrusion rings for optimum sealability and life.
10. **Bonnet locking collar** (unwelded valves only).
11. **Bonnet seal ring** is die-formed flexible graphite gasket seated to a prescribed bonnet torque to provide reliable bonnet seal.
12. **Integral backseat** provides a secondary stem seal backup for positive shutoff and leak protection.

## Parts Specification List for Edward Univalve® Valves

### Standard Features

- Available body material
  - SA 105 carbon steel
  - SA 182 Grade F22
  - SA 182 Grade F316
- Unwelded (graphitic seal) or wealed bonnet
- OS & Y
- Y Pattern
- Body-guided investment cast Stellite disc
- Integral Stellite seat
- Integral backseat
- Asbestos-free graphitic packing

Edward Univalves for nuclear service are normally furnished in standard Class 1500 or 2500. Other interpolated pressure classes are also available on application.

Parts shown are not applicable to Univalve® valves. Construction and materials for nuclear valves may vary depending upon customer design specifications. For a complete, accurate and itemized description of a particular valve, contact your local Flowserve valves sales representative.

Description	ASME/ASTM No.	ASME/ASTM No.	ASME/ASTM No.
<b>Body</b>	SA-105 —	SA-182 Grade F-22	SA-182 Grade F316
<b>Bonnet</b>	SA-696 Grade C	SA-739 Grade B-22	SA-479 T-316
<b>Stem</b>	A-582 T-416 —	A-582 T-416 —	SA-564 T-630 Condition H-1100
<b>Disc Size ½–2</b>	A-732 Grade 21	A-732 Grade 21	A-732 Grade 21
<b>Disc Size 2½–4</b>	SA-182 F316 Stellite Faced	SA-182 F316 Stellite Faced	SA-182 F316 Stellite Faced
<b>Body Seat</b>	Stellite 21	Stellite 21	Stellite 21
<b>Junk Ring</b>	— —	— —	A-732 Grade 21
<b>Packing Rings</b>	Flexible Graphite System	Flexible Graphite System	Flexible Graphite System
<b>Gland</b>	A-182 Grade F6a	A-182 Grade F6a	A-732 Grade 21
<b>Gland Adjusting Screw</b>	A-582 T-416	A-582 T-416	A-564 T-630
<b>Yoke</b>	A-181 Class 70	A-181 Class 70	A-181 Class 70
<b>Yoke Bushing</b>	B150 C61900/62300	B150 C61900/62300	B150 C61900/62300
<b>Yoke Bolt</b>	A-307 Grade A-Plated	A-307 Grade A-Plated	A-564 T-630
<b>Yoke Bolt Nut</b>	A-563 Grade A-Plated	A-563 Grade A-Plated	A-194 Grade 8
<b>Handwheel Impactor Handle</b>	Malleable or Ductile Iron	Malleable or Ductile Iron	Malleable or Ductile Iron
<b>Stem Nut</b>	Mild Steel Plated	Mild Steel Plated	Mild Steel Plated
<b>Adapter</b>	Malleable or Ductile Iron	Malleable or Ductile Iron	Malleable or Ductile Iron
<b>Washer</b>	Mild Steel Plated	Mild Steel Plated	Mild Steel Plated
<b>Bonnet Seal Ring**</b>	Graphite	Graphite	Graphite
<b>Locking Collar**</b>	Cast Steel	Cast Steel	Cast Steel
<b>Spring*</b>	A-313 T-302	A-313 T-302	A-313 T-302

Cobalt-free materials available for wetted parts.

\*Check valves only. \*\*Unwelded valves only.

## Univalve® Stop Valves, Class 1500

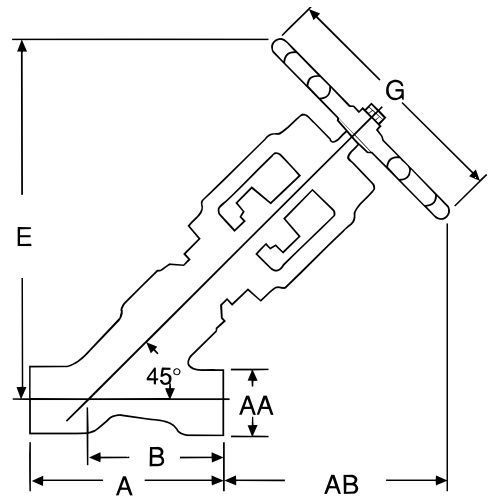

36124

### Standard Features

- Available body materials
  - SA105 carbon steel
  - F22 alloy steel
  - F316
  - Other material on application
- Unwelded (graphitic seal) or welded bonnet
- OS & Y
- Y Pattern

### Pressure Class 1500 (PN 260)

Fig. No.		Type	Ends	NPS (DN)
Welded	Unweld.			
36124	36224	Y Pattern	Socket Weld	½ (15) thru 2½ (65)
36128	36228	Y Pattern	Butt Weld	½ (15) thru 4 (100)

- Body-guided investment cast Stellite disc
- Integral Stellite seat
- Integral backseat
- Asbestos-free graphitic packing

### Dimensions – Globe

Black numerals are in inches and pounds  
Colored numerals are in millimeters and kilograms

Figure No. 36124, 36128, 36224, 36228	NPS	½	¾	1	1¼	1½	2	2½	3	4
	DN	15	20	25	32	40	50	65	80	100
A - End to End		6.0	6.0	6.0	6.7	6.7	8.2	10.7	10.7	12.8
		152	152	152	170	170	208	272	272	325
AA - End Hub Diameter		2.30	2.30	2.30	3.20	3.20	3.64	4.00	4.00	4.80
		58	58	58	81	81	92	102	102	122
AB - Handwheel Clearance (Open)		7.5	7.5	7.5	11.0	11.0	11.6	12.5	12.5	11.2
		191	191	191	279	279	295	318	318	284
B - Center to End		4.0	4.0	4.0	4.8	4.8	6.1	7.1	7.1	8.8
		102	102	102	122	122	155	180	180	224
E - Center to Top (Open)		11.5	11.5	11.5	15.9	15.9	17.7	19.6	19.6	20.0
		292	292	292	404	404	450	498	498	508
G - Handwheel/Handle Diameter		8.5	8.5	8.5	14.3*	14.3*	14.3*	16.0**	16.0**	16.0**
		216	216	216	363*	363*	363*	406**	406**	406**
Weight, Welded		19	19	19	36	36	57	100	100	138
		9	9	9	16	16	26	46	46	63
Weight, Unwelded		20	20	20	38	38	59	104	104	142
		9	9	9	17	17	27	47	47	64

\* Impactor Handle \*\*Impactor Handwheel

Refer to page 63 for materials of construction.

Refer to pages 203 through 238 for the applicable pressure ratings.



# Univalve® Stop-Check Valves, Class 1500

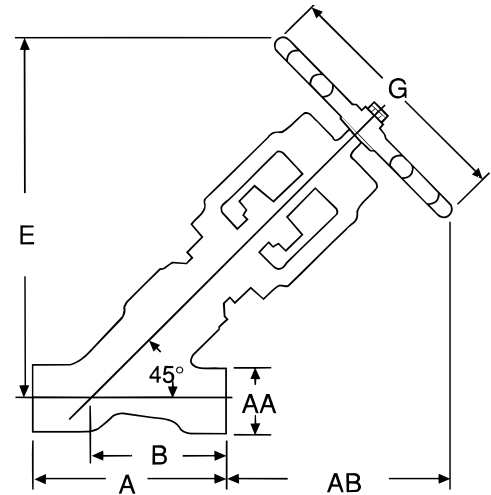

36164

## Standard Features

- Available body materials
  - SA105 carbon steel
  - F22 alloy steel
  - F316 stainless steel
- Unwelded (graphitic seal) or welded bonnet
- OS & Y
- Y Pattern
- Body-guided investment cast Stellite disc
- Integral Stellite seat
- Integral backseat
- Asbestos-free graphitic packing

## Pressure Class 1500 (PN 260)

Fig. No.		Type	Ends	NPS (DN)
Welded	Unweld.			
36164	36264	Y Pattern	Socket Weld	½ (15) thru 2½ (65)
36168	36268	Y Pattern	Butt Weld	½ (15) thru 4 (100)

## Dimensions – Globe

Black numerals are in inches and pounds  
Colored numerals are in millimeters and kilograms

Figure No. 36164, 36168, 36264, 36268	NPS	½	¾	1	1¼	1½	2	2½	3	4
	DN	15	20	25	32	40	50	65	80	100
A - End to End		6.0	6.0	6.0	6.7	6.7	8.2	10.7	10.7	12.8
		152	152	152	170	170	208	272	272	325
AA - End Hub Diameter		2.30	2.30	2.30	3.20	3.20	3.64	4.00	4.00	4.80
		58	58	58	81	81	92	102	102	122
AB - Handwheel Clearance (Open)		7.5	7.5	7.5	11.0	11.0	11.6	12.5	12.5	11.2
		191	191	191	279	279	295	318	318	284
B - Center to End		4.0	4.0	4.0	4.8	4.8	6.1	7.1	7.1	8.8
		102	102	102	122	122	155	180	180	224
E - Center to Top (Open)		11.5	11.5	11.5	15.9	15.9	17.7	19.6	19.6	20.0
		292	292	292	404	404	450	498	498	508
G - Handwheel/Handle Diameter		8.5	8.5	8.5	14.3*	14.3*	14.3*	16.0**	16.0**	16.0**
		216	216	216	363*	363*	363*	406**	406**	406**
Weight, Welded		19	19	19	36	36	57	100	100	138
		9	9	9	16	16	26	46	46	63
Weight, Unwelded		20	20	20	38	38	59	104	104	142
		9	9	9	17	17	27	47	47	64

\* Impactor Handle \*\* Impactor Handwheel

Refer to page 63 for materials of construction.

Refer to pages 203 through 238 for the applicable pressure ratings.

## Univalve® Stop Valves, Class 2500

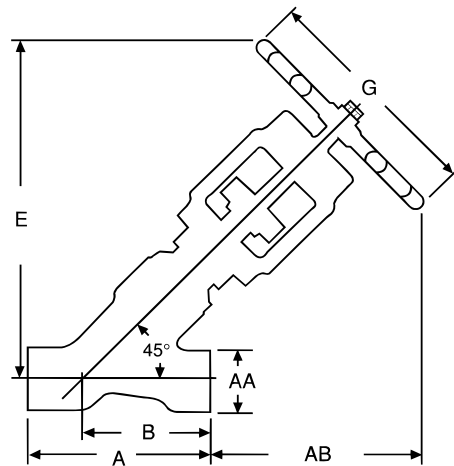

66124

### Standard Features

- Available body material
  - SA105 carbon steel
  - F22 alloy steel
  - F316 stainless steel
  - Other material on application
- Unwelded (graphitic seal) or welded bonnet
- OS & Y
- Y Pattern
- Body-guided investment cast Stellite disc

### Pressure Class 2500 (PN 420)

Fig. No.		Type	Ends	NPS (DN)
Welded	Unweld.			
66124	66224	Y Pattern	Socket Weld	½ (15) thru 2½ (65)
66128	66228	Y Pattern	Butt Weld	½ (15) thru 4 (100)

- Integral Stellite seat
- Integral backseat
- Asbestos-free graphitic packing

### Dimensions – Globe

Black numerals are in inches and pounds  
Colored numerals are in millimeters and kilograms

Figure No. 66124, 66128, 66224, 66228	NPS	½	¾	1	1-¼	1-½	2	2-½	3	4
	DN	15	20	25	32	40	50	65	80	100
A - End to End		6.0	6.0	6.0	6.7	6.7	10.7	12.8	12.8	12.8
		152	152	152	170	170	272	325	325	325
AA - End Hub Diameter		2.30	2.30	2.30	3.20	3.20	4.00	4.80	4.80	4.80
		58	58	58	81	81	102	122	122	122
AB - Handwheel Clearance, (Open)		7.5	7.5	7.5	9.8	9.8	11.6	11.2	11.2	11.2
		191	191	191	249	249	296	284	284	284
B - Center to End		4.0	4.0	4.0	4.8	4.8	7.1	8.8	8.8	8.8
		102	102	102	122	122	180	224	224	224
E - Center to Top, (Open)		11.5	11.5	11.5	14.6	14.6	18.6	20.0	20.0	20.0
		292	292	292	371	371	472	508	508	508
G - Handwheel/Handle Diameter		8.5	8.5	8.5	11.0*	11.0*	14.3*	16.0**	16.0**	16.0**
		216	216	216	279*	279*	363*	406**	406**	406**
Weight, Welded		19	19	19	34	34	79	142	142	142
		9	9	9	16	16	36	65	65	65
Weight, Unwelded		20	20	20	36	36	83	146	146	146
		9	9	9	17	17	38	66	66	66

\* Impactor Handle \*\* Impactor Handwheel

Refer to page 63 for materials of construction.

Refer to pages 203 through 238 for the applicable pressure ratings.

## Univalve® Stop-Check Valves, Class 2500

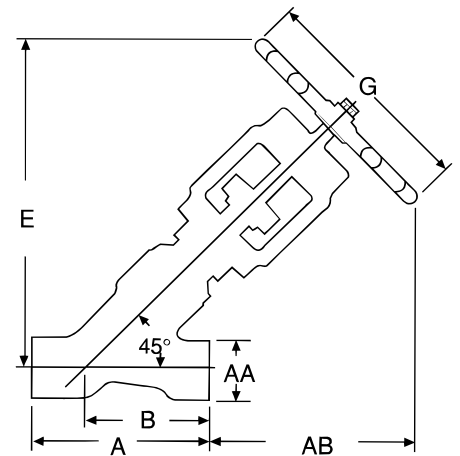

66164

### Standard Features

- Available body material
  - SA105 carbon steel
  - F22 alloy steel
  - F316 stainless steel
  - Other material on application
- Unwelded (graphitic seal) or welded bonnet
- OS & Y
- Y Pattern
- Body-guided investment cast Stellite disc

### Pressure Class 2500 (PN 420)

Fig. No.		Type	Ends	NPS (DN)
Welded	Unweld.			
66164	66264	Y Pattern	Socket Weld	½ (15) thru 2½ (65)
66168	66268	Y Pattern	Butt Weld	½ (15) thru 4 (100)

- Integral Stellite seat
- Integral backseat
- Asbestos-free graphitic packing

### Dimensions – Globe

Black numerals are in inches and pounds  
Colored numerals are in millimeters and kilograms

Figure No. 66164, 66168, 66264, 66268	NPS	½	¾	1	1¼	1½	2	2½	3	4
	DN	15	20	25	32	40	50	65	80	100
A - End to End		6.0	6.0	6.0	6.7	6.7	10.7	12.8	12.8	12.8
		152	152	152	170	170	272	325	325	325
AA - End Hub Diameter		2.30	2.30	2.30	3.20	3.20	4.00	4.80	4.80	4.80
		58	58	58	81	81	102	122	122	122
AB - Handwheel Clearance (Open)		7.5	7.5	7.5	9.8	9.8	11.6	11.2	11.2	11.2
		191	191	191	249	249	295	284	284	284
B - Center to End		4.0	4.0	4.0	4.8	4.8	7.1	8.8	8.8	8.8
		102	102	102	122	122	180	224	224	224
E - Center to Top (Open)		11.5	11.5	11.5	14.6	14.6	18.6	20.0	20.0	20.0
		292	292	292	371	371	472	508	508	508
G - Handwheel/Handle Diameter		8.5	8.5	8.5	11.0*	11.0*	14.3*	16.0**	16.0**	16.0**
		216	216	216	279*	279*	363*	406**	406**	406**
Weight, Welded		19	19	19	34	34	79	142	142	142
		9	9	9	16	16	36	65	65	65
Weight, Unwelded		20	20	20	36	36	83	146	146	146
		9	9	9	17	17	38	66	66	66

\* Impactor Handle \*\*Impactor Handwheel

Refer to page 63 for materials of construction.

Refer to pages 203 through 238 for the applicable pressure ratings.

***Features and Description of Edward Hermavalue®  
Hermetically Sealed Valves***

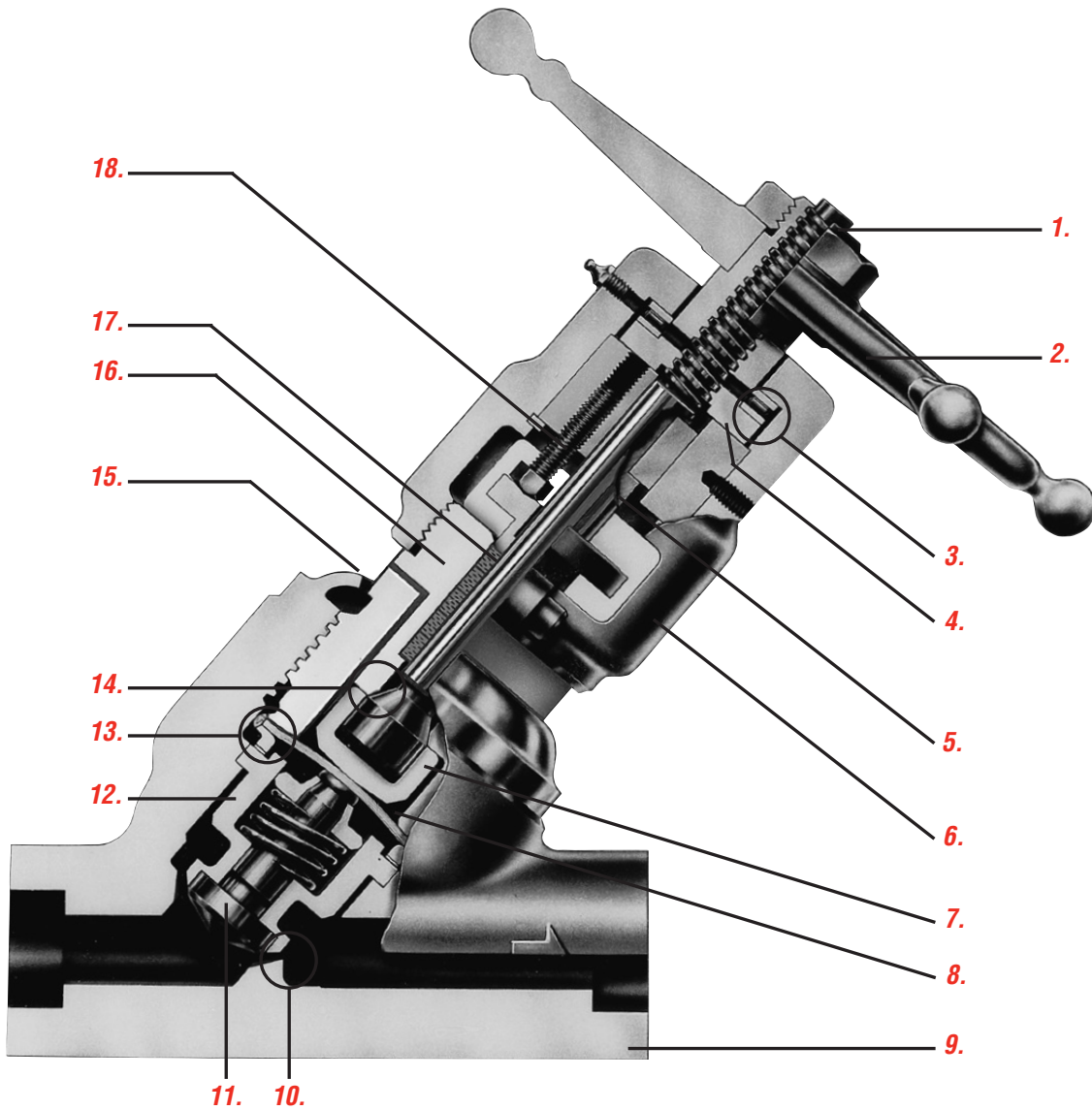

## Features and Description of Edward Hermavalve® Hermetically Sealed Valves

1. **Position indicator** shows whether the valve is open or closed.
2. **Handwheel** is rugged and knobbed to permit sure grip even when wearing gloves.
3. **Needle thrust bearings** minimize torque. Their upper yoke location protects from heat and allows lubrication.
4. **Yoke bushing.** Revolving bushing of aluminum bronze material has low coefficient of friction, substantially reduces torque, stem wear and eliminates galling.
5. **Non-revolving stem** is stainless steel. It is ground to a fine finish and keyed to the yoke to prevent rotation and torsional stress on the diaphragm.
6. **Yoke** of carbon steel is electroless nickel plated for corrosion resistance.
7. **Diaphragm disc** is a unique shape that maximizes diaphragm life.
8. **Diaphragm** of multi-ply flexible metal provides a reliable primary stem seal.
9. **Body** with inclined stem construction and unique flow shape minimizes flow directional changes and cuts pressure drop.
10. **Integral hardfaced seat** of hard, heat-resistant hardfacing material is integrally welded to the body.
11. **Solid Stellite disc** ensures maximum seating life.
12. **Disc guide assembly** ensures disc/seat alignment. Its completely encapsulated spring ensures full disc lift.
13. **Diaphragm seal weld** is a unique seal weld, which makes the diaphragm an integral part of the bonnet and eliminates a potential leak path past the stem.
14. **Backseat** provides a secondary stem seal backup.
15. **Body-bonnet seal** features leak-proof seal-welded construction. The weld is for seal only; the threaded section carries the pressure load. Canopy weld in stainless steel; fillet weld in carbon steel.
16. **Bonnet** is barstock steel with gall-resistant ACME threads to ensure easy disassembly from body.
17. **Backup packing** with OS & Y design allows for inspection or addition of packing without disassembling valve.
18. **Adjustable gland screws** with OS & Y design allow for easy access to packing adjustment, if necessary.

What is a Hermavalve? A Hermavalve is a hermetically sealed valve that cannot leak to the environment. The Edward Hermavalve cannot leak because it is double-seal welded:

1. The multi-ply flexible metal diaphragm is seal welded to the bonnet.
2. The body-to-bonnet joint is also seal welded.

This unique construction eliminates any potential leakage through a mechanical joint. It is more than just packless. It is hermetically sealed.

Zero leakage to environment—Welded, hermetic design and dependable metal diaphragm help to ensure zero leakage for the life of the valve. In approved services, the valve is warranted against leakage to the environment.

High-efficiency flow-shape—Unique flow shape ensures high  $C_v$  comparable to or greater than conventionally packed valves—proven by extensive flow testing.

Non-revolving stem design—Ensures lowest possible operating torque and is the only absolute method of avoiding diaphragm damage caused by rotational forces from a revolving stem.

Two backup stem seals—1) Packing and 2) backseat provide backup seals.

Nuclear quality—Available to ASME Section III—Class 1, 2, 3.



## Parts Specification List for Edward Hermavalve®

Construction and materials for nuclear valves may vary depending upon customer design specifications. For a complete, accurate and itemized description of a particular valve, contact your Flowserve Edward valves sales representative.

Description	ASME/ASTM No.	ASME/ASTM No.
Body	SA-105	SA-182 Grade F316
Disc	A-732 Grade 21	A-732 Grade 21
Body Seat	Stellite 21	Stellite 21
Stem	A-582 T-416	SA-564 T-630 Cond. H-1100
Junk Ring	A-582 T-416	A-582 T-416
Bonnet	SA-696 Grade C	SA-479 T316
Yoke Bolt	A-193 Grade B6	A-564 T-630
Packing	Flexible Graphite System	Flexible Graphite System
Gland	A-582 T-416	A-564 T-630
Retaining Ring	Nickel-Plated Steel	Nickel Plated Steel
Gland Adjusting Screw	A-193 Grade B6	A-564 T630
Stem Guide Bushing	A-696 Grade C Nickel Plated	A-696 Grade C Nickel Plated
Yoke Bolt Nut	A-194 Grade 6F	A-194 Grade 8
Yoke	A-216 Grade WCB Nickel Plated	A-216 Grade WCB Nickel Plated
Yoke Bushing	B-150 Alloy C61900 - C62300	B-150 Alloy C61900 - C62300
Drive Pin	A-564 T630	A-564 T630
Key	A-331 Grade 4140	A-331 Grade 4140
Spring Housing	A-582 T-416	A-564 T-630
Diaphragm Ring	SA-696 Grade C	SA-479 T-316
Diaphragm Assembly	B-670 Alloy 718 (Inconel)	B-670 Alloy 718 (Inconel)
Diaphragm Disc	A-732 Grade 21	A-732 Grade 21
Shims	A-167 T-316	A-167 T-316
Disc Collar	A-565 Grade 616	A-565 Grade 616
Spring	Inconel X-750	Inconel X-750
Handwheel	Malleable or Ductile Iron	Malleable or Ductile Iron
Handwheel Nut	Nickel-Plated Steel	Nickel-Plated Steel
Indicator	A-479 T-316	A-479 T-316
Thrust Bearing	Steel	Steel
Lube Fitting	Nickel-Plated Steel	Nickel-Plated Steel

Note: Cobalt-free materials available for wetted parts.

# Hermavalue® Hermetically Sealed Valves ASME SECTION III – Code Class 1, 2, or 3

## Nuclear Service Guarantee

Zero leakage to environment for 40 years or 4000 cycles, or we replace the valve at NO COST. For detailed warranty statement, consult your Flowserve Edward valves representative.

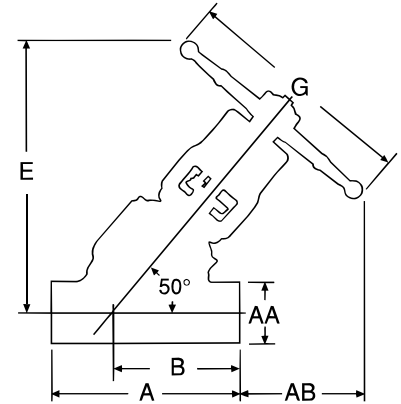

## Standard Features

- SA105 or SA182 Grade F316 body and bonnet
- Seal-welded diaphragm and seal-welded body/bonnet joint
- OS & Y
- Y Pattern
- Non-revolving stem with position indicator
- Back-up asbestos-free graphitic packing and secondary stem backseat
- Integral hardfaced seat
- Knobbed handwheel

## Pressure Class 1690 (PN 290)

Fig. No.	Material	Ends	Port	NPS (DN)
15004	Carbon Steel	Socket Weld	Regular	½ (15) thru 2 (50)
15008	Carbon Steel	Butt Weld	Regular	
15014	Carbon Steel	Socket Weld	Reduced	1 (25) thru 2-½ (40)
15018	Carbon Steel	Butt Weld	Reduced	
15104	Stainless Steel	Socket Weld	Regular	½ (15) thru 2 (50)
15108	Stainless Steel	Butt Weld	Regular	
15114	Stainless Steel	Socket Weld	Reduced	1 (25) thru 2-½ (40)
15118	Stainless Steel	Butt Weld	Reduced	

## Dimensions

Black numerals are in inches and pounds  
Colored numerals are in millimeters and kilograms

Figure No. 15004, 15008, 15014, 15018, 15104, 15108, 15114, 15118	NPS DN	Regular Port					Reduced Port			
		½	¾	1	1-½	2	1	1-½*	2	2-½
		15	20	25	40	50	25	40	50	65
A - End to End		5.5 140	5.5 140	6.62 168	8.7 220	10 254	5.5 140	6.62 168	8.7 220	10 254
AA - End Hub Diameter		2.06 52	2.06 52	2.12 54	3.4 86	3.4 86	2.06 52	2.12 54	3.4 86	3.4 86
AB - Handwheel Clearance (Open)		4.62 117	4.62 117	5.69 145	9.06 230	10.88 276	4.62 117	5.69 145	9.06 230	10.88 276
E - Center to Top		9.12 232	9.12 232	11.19 284	16 406	18.5 470	9.12 232	11.19 284	16 406	18.5 470
B - Center to End		3.8 97	3.8 97	4.62 117	6 152	6.86 174	3.8 97	4.62 117	6 152	6.86 174
G - Handwheel Diameter		7.12 181	7.12 181	8.5 216	11.5 292	15 381	7.12 181	8.5 216	11.5 292	15 381
Weight		18 8	18 8	30 14	73 33	106 48	18 8	30 14	73 33	106 48

\*Available in butt weld only.

Refer to page 70 for materials of construction.

Refer to pages 203 through 238 for the applicable pressure ratings.

## Features and Description of Flowserve Edward Stop-Check (Non-Return) Valves

Flowserve Edward stop-check (non-return) valves offer the same tight-sealing performance as Edward stop valves, and at the same time, give check valve protection in the event of fluid back flow. Edward stop-check valves are commonly used to prevent back flow from a header fed from two or more sources when there is a loss of pressure in one of the sources—for example, the boiler outlet to a common header or at the feedwater heater outlets.

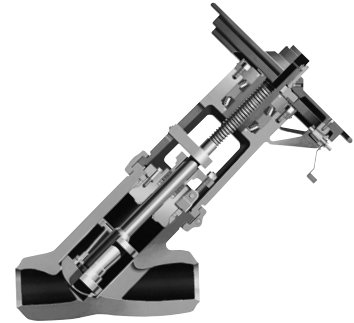
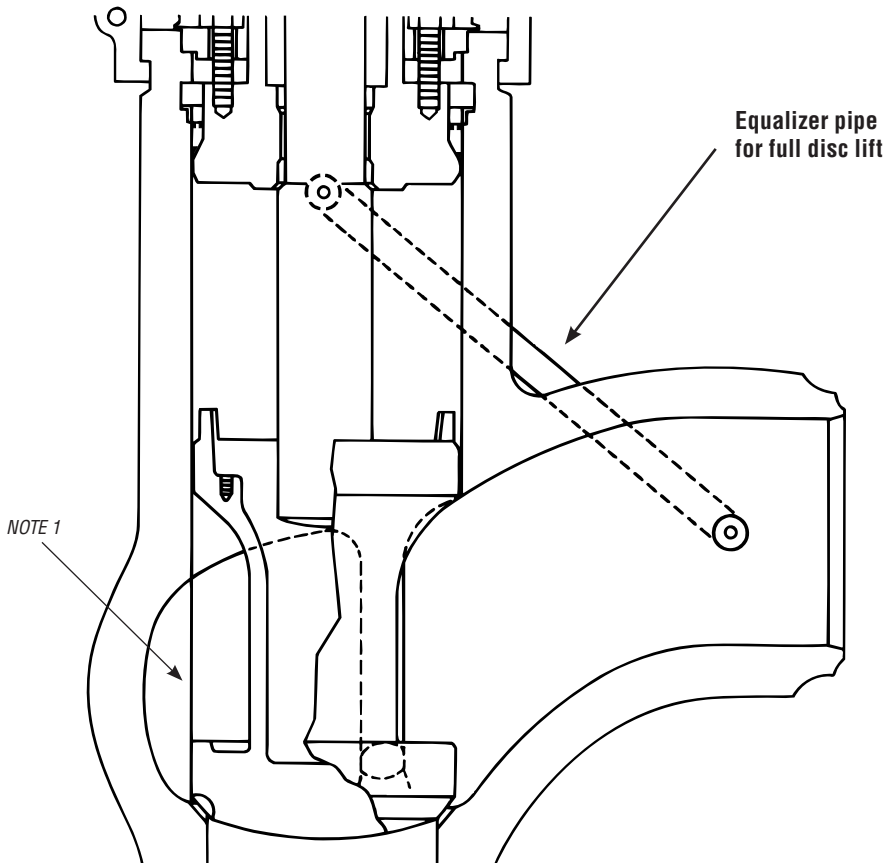

Flite-Flow®

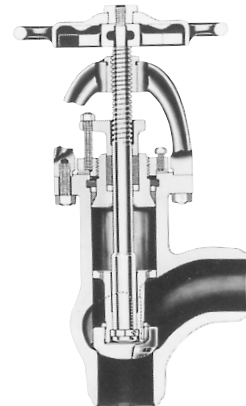

Angle

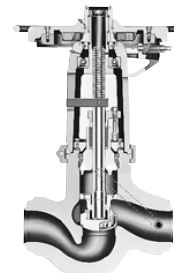

Globe

### Equalizer

Flowserve Edward cast steel stop-check valves are equipped with an Equalizer pipe. Acting as an external pressure balancing pipeline, the Equalizer connects the zone above the disc with the lower pressure area in the valve outlet (see drawing above). This reduces pressure above the disc, and as a result, causes the higher pressure below the disc to raise the disc to full lift. The Equalizer helps reduce pressure drop and disc-piston movement and wear.

**Other features are the same as those defined on page 74 for stop valves.**

*NOTE 1: Guide ribs are hardfaced on Flite-Flow and some angle pattern valves.*



## Parts Specification List for Edward Globe Valves, Stop-Check and Piston Lift Check

This is not a complete list. Construction and materials will vary between sizes and pressure classes and may be changed without notice. For a complete, accurate and itemized description of a particular valve, contact your Flowserve Edward valves sales representative.

Description <sup>(1)</sup>	ASME/ASTM No.	ASME/ASTM No.	ASME/ASTM No.	ASME/ASTM No.
Body/Bonnet*	SA-216 Grade WCB	SA-216 Grade WCC	SA-217 Grade WC9	SA-351 Grade CF8M
Disc	SA-105 —	SA-105 —	A-182 Grade F22	A-182 Grade F316
Body-Guided Disc Nut	A-216 Grade WCB	A-216 Grade WCB	A-217 Grade WC9	A-182 Grade F316
Stem	A-182 Grade F6a	A-182 Grade F6a	A-565 Grade 616 HT	A-638 Grade 660 T2
Yoke Bushing	B-148 Alloy 95400	B-148 Alloy 95400	B-148 Alloy 95400	B-148 Alloy 95400
Packing Rings	Flexible Graphite inner rings and suitable anti-extrusion rings.			
Junk Rings	A-108 Grade 1018-20 MnPO <sub>4</sub> Plated	A-108 Grade 1018-20 MnPO <sub>4</sub> Plated	A-108 Grade 1018-20 MnPO <sub>4</sub> Plated	A-182 Grade F316/Stellite I.D.
Pressure Seal Gasket	Composite Pressure Seal Gasket.			
Spacer Ring	A-668 Grade 4140 MnPO <sub>4</sub> Plated	A-668 Grade 4140 MnPO <sub>4</sub> Plated	A-668 Grade 4140 MnPO <sub>4</sub> Plated	A-182 Grade F6 CL4
Gasket Retainer	SA-182 Grade F6 CL4	SA-182 Grade F6 CL4	A-565 Grade 616 HT	A-638 Grade 660 T2
Bonnet Retainer	A-216 Grade WCB	A-216 Grade WCB	A-216 Grade WCB	A-216 Grade WCB
Bonnet Retainer Studs	A-193 Grade B7	A-193 Grade B7	A-193 Grade B7	A-193 Grade B7
Bonnet Retainer Nuts	A-194 Grade 2H	A-194 Grade 2H	A-194 Grade 2H	A-194 Grade 2H
Gland	A-148 Grade 90-60	A-148 Grade 90-60	A-148 Grade 90-60	A-148 Grade 90-60/Chrome Plated
Eye Bolt	A-193 Grade B7/Cad. Plated	A-193 Grade B7/Cad. Plated	A-193 Grade B7/Cad. Plated	A-193 Grade B7/Cad. Plated
Eye Bolt Nuts	A-194 Grade 2H/Cad. Plated	A-194 Grade 2H/Cad. Plated	A-194 Grade 2H/Cad. Plated	A-194 Grade 2H/Cad. Plated
Eye Bolt Pins	A-182 Grade F6a Class 4	A-182 Grade F6a Class 4	A-182 Grade F6a Class 4	A-182 Grade F6a Class 4
Stem Guide Collar	A-515 Grade 70	A-515 Grade 70	A-515 Grade 70	A-515 Grade 70
Stem Guide Key	A-331 Grade 4140 HT	A-331 Grade 4140 HT	A-331 Grade 4140 HT	A-331 Grade 4140 HT
Yoke	A-216 Grade WCB	A-216 Grade WCB	A-216 Grade WCB	A-216 Grade WCB
Yoke Lock Ring	A-216 Grade WCB	A-216 Grade WCB	A-216 Grade WCB	A-216 Grade WCB
Yoke Lock Ring Studs	A-193 Grade B7	A-193 Grade B7	A-193 Grade B7	A-193 Grade B7
Yoke Lock Ring Nuts	A-194 Grade 2H	A-194 Grade 2H	A-194 Grade 2H	A-194 Grade 2H
Impactor Handwheel	A-126 Class A	A-126 Class A	A-126 Class A	A-126 Class A
Crossarm, Handwheel	A-536 Grade 65-45-12	A-536 Grade 65-45-12	A-536 Grade 65-45-12	A-536 Grade 65-45-12
Handwheel Bearing Nut	A-536 Grade 65-45-12	A-536 Grade 65-45-12	A-536 Grade 65-45-12	A-536 Grade 65-45-12
Stem Collar	A-182 Grade F6a	A-182 Grade F6a	A-565 Grade 616 HT	A-638 Grade 660 T2

(1) Through Class 2500, for Series 4500 valves, some construction differences exist. Contact your Edward valves sales representative for more information.

\* Other material grades available on application.

## Features and Description of Edward Flite-Flow® Globe Valves

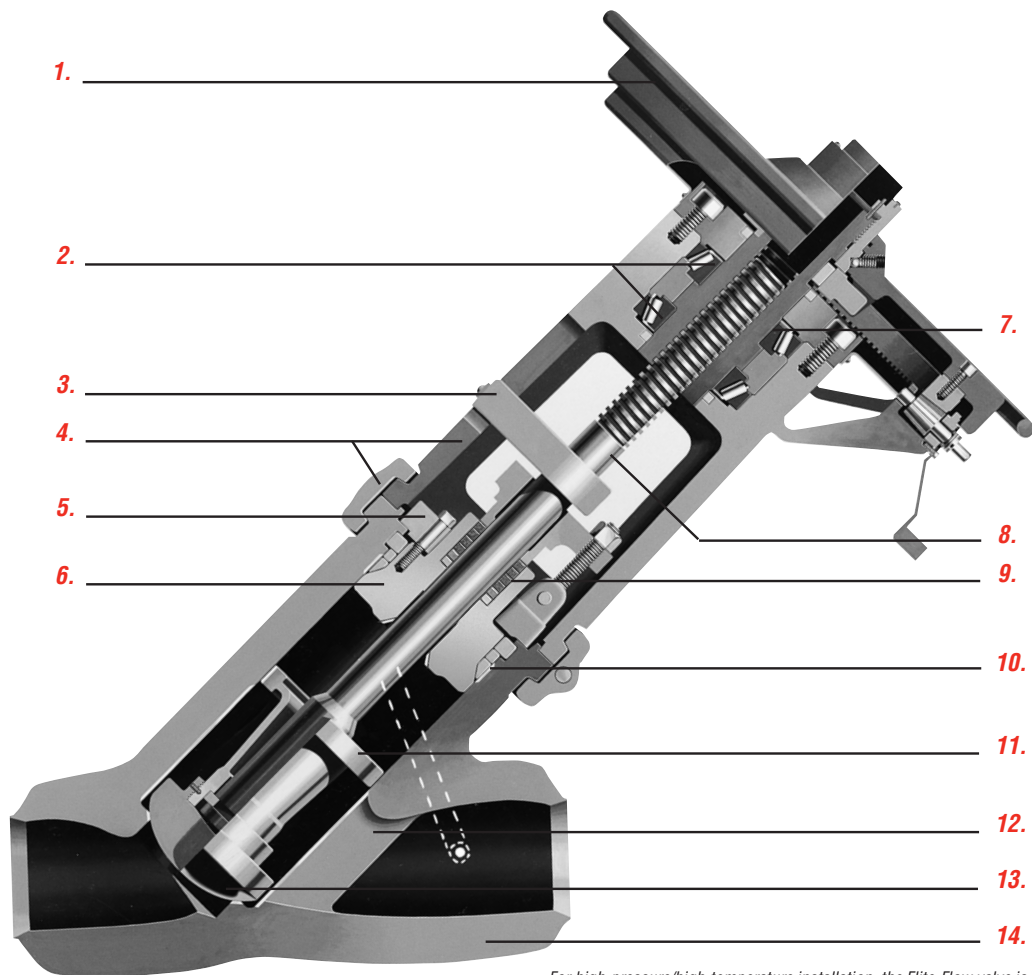

*For high-pressure/high-temperature installation, the Flite-Flow valve is capable of handling millions of pounds per hour of fluid flow—without sacrificing low-pressure drop or piping flexibility.*

- 1. Impactor handwheel** provides many times the closing force of an ordinary handwheel for positive seating. Impactogear, available on larger sizes, allows cycling by one man utilizing the air wrench adaptor.
- 2. Thrust bearings** minimize torque requirements and eliminate side loading due to out-of-position orientation. Smoother operation and longer valve life are possible.
- 3. Stem guide collar** prevents stem rotation and provides valve position indication.
- 4. Yoke/Yoke lock ring** - the yoke is designed for ready access to the packing chamber, and the lock ring allows quick disassembly for maintenance.
- 5. Bonnet retainer** provides loading to effect a seal at the pressure seal gasket.
- 6. Bonnet** is precision machined, retains packing and provides an integral hardfaced stem backseat.
- 7. Yoke bushing material** has low coefficient of friction that substantially reduces torque and thread wear and eliminates galling.
- 8. Stem** has ACME threads, is machined to a fine finish and is heat treated for improved strength and hardness to resist wear.
- 9. Stem packing system** utilizes flexible graphite packing material with anti-extrusion rings for optimum sealability and life.
- 10. Composite pressure seal gasket** is a preloaded, pressure energized design for long, reliable service.
- 11. Disc piston** is body guided to eliminate misalignment, galling and stem bending.
- 12. Guide ribs** - hardfaced on Flite-Flow and some angle patterns, provide body guiding for disc/piston assemblies.
- 13. Integral hardsurfaced seats** - both body and disc provide shut-off and long seat life.
- 14. Body** utilizes optimized flow passages to minimize flow direction changes and reduce pressure drop.

## Special Application Valves

### Flowserve - Edward Throttle Valves

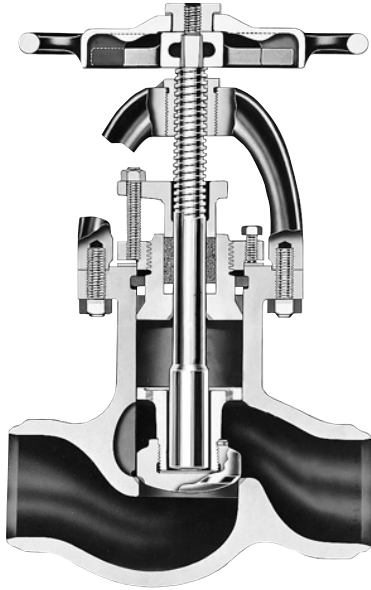

Edward standard cast steel valves with the body-guided feature have excellent ability to handle flow at high-pressure differentials. However, for improved accuracy, cast globe and angle stop valves can be equipped with a special throttle disc. Disc shape provides good regulation over wide ranges of flow. When required, valves equipped with a throttle disc may also be ordered with a motor operator. Edward cast stop valves equipped with a throttle disc are identified by adding the suffix "K" to the standard valve figure number.

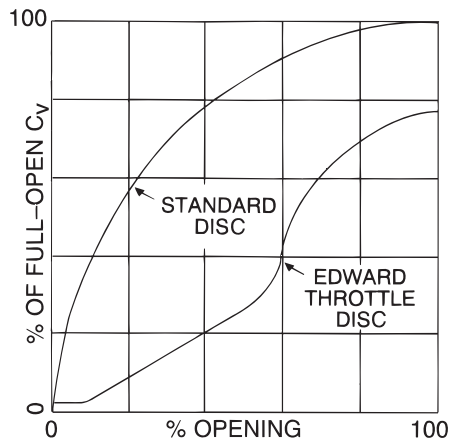

#### Comparison Curves of Typical Standard Disc with Throttle Disc

The standard stop valve disc gives rapid increases in flow for each increment of lift at low lifts and small increases in flow at higher lifts. This is not desirable in many applications where the valve is used for controlling flow rate. The conical projection on the throttle disc gives straight line control at the lower lifts as long as it remains in the seat. Once the cone lifts entirely out of the seat, it permits high capacity at high lifts with only moderate pressure drop penalty.

## Stop Valves, Class 600

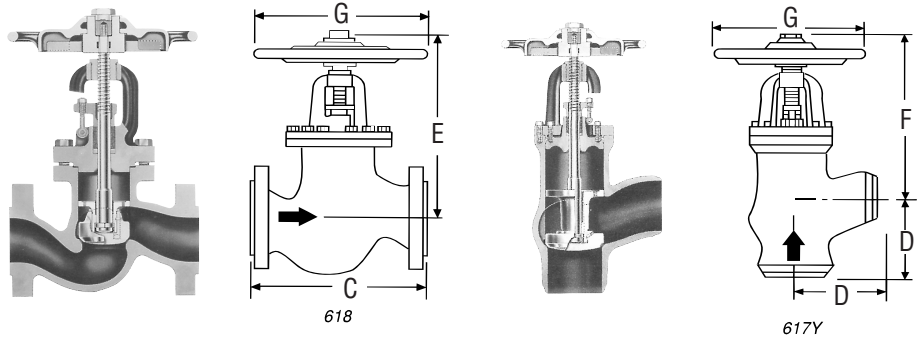

### Standard Features

- Bodies and bonnets are cast steel (WCB, WCC, WC9, CF8M)
- Bolted or pressure-seal bonnet, OS & Y
- Globe or angle
- Integral Stellite seat, disc and backseat
- Body-guided disc piston
- 13% chromium stainless steel stem
- Asbestos-free graphitic packing
- Long Terne steel or composite pressure-seal gasket

### Pressure Class 600 (PN 110)

FIG. NO.		TYPE	ENDS	BONNET	NPS (DN)
STD CL	SPL CL				
616	—	Globe	Flanged	Bolted Pressure Seal	8 (200) thru 14 (350)
616Y	716Y	Globe	Butt Weld	Bolted Pressure Seal	
617	—	Angle	Flanged	Bolted Pressure Seal	8 (200) thru 14 (350), 24 (600), 28 (700) & 30 (750)
617Y	717Y	Angle	Butt Weld	Bolted Pressure Seal	
618	—	Globe	Flanged	Bolted	2½ (65) thru 6 (150)
618Y	—	Globe	Butt Weld	Bolted	
619	—	Angle	Flanged	Bolted	
619Y	—	Angle	Butt Weld	Bolted	

### Dimensions – Globe & Angle\*

Black numerals are in inches and pounds  
Colored numerals are in millimeters and kilograms

Figure No. 616/616Y, 617/617Y, 618/618Y, 619/619Y, 716Y, 717Y	NPS	2½	3	4	5	6	8	10	12	14
	DN	65	80	100	125	150	200	250	300	350
C - Face to Face, Globe •		13	14	17	20	22	26	31	33	35
		330	356	432	508	559	660	787	838	889
D - Center to Face, Angle •		6.5	7	8.5	10	11	13	15.5	16.5	17.5
		165	178	216	254	279	330	394	419	445
E - Center to Top, Globe		16.2	16.7	20.1	24.8	28.4	34.3	39.7	43.6	47
		411	424	511	630	721	871	1008	1107	1194
F - Center to Top, Angle		14.4	14.6	17.7	21.4	24.2	28.8	32.9	36.1	38.8
		366	371	450	544	615	731	836	917	986
G - Handwheel/Handle Diameter**		12	12	14	16	16	20	26	30	30
		305	305	356	406	406	508	660	762	762
Weight, Globe (Flanged)		110	135	245	425	525	900	1550	2200	2640
		50	61	111	193	238	408	703	998	1198
Weight, Globe (Welding)		90	110	180	315	400	750	1200	1850	2250
		41	50	82	143	181	340	544	839	1021
Weight, Angle (Flanged)		100	122	228	355	460	730	1230	1790	2120
		45	55	103	161	209	331	558	812	962
Weight, Angle (Welding)		100	125	170	245	350	540	950	1450	1760
		45	57	77	111	159	245	431	658	798

\* Angle valves only. Also available in sizes 24, 28 and 30. Dimensions available upon request. \*\* Impactor handwheel is standard on all size valves.

• Center-to-end or end-to-end dimensions for welding and valves same as center-to-contact-face or contact-face-to-contact-face dimensions for flanged end valves.

Refer to page 73 for materials of construction.

Refer to pages 203 through 238 for the applicable pressure ratings.

## Stop Valves, Class 600

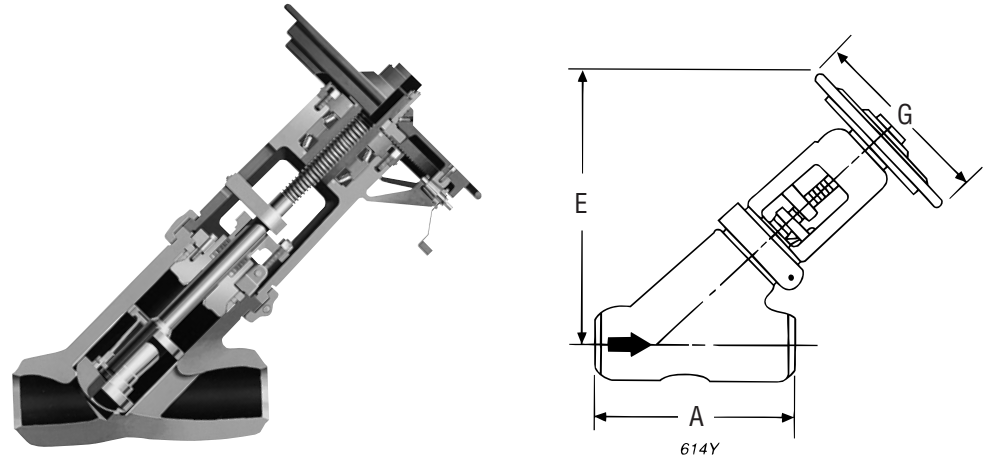

### Standard Features

- Bodies and bonnets are cast steel (WCB, WCC, WC9, CF8M)
- Pressure-seal bonnet, OS & Y
- Y Pattern
- Integral Stellite seat, disc and backseat
- Body-guided disc piston
- 13% chromium stainless steel stem
- Asbestos-free graphite packing
- Spiral-wound or composite pressure-seal gasket

### Pressure Class 600 (PN 110)\*

Fig. No.		Type	Ends	Bonnet	NPS (DN)
STD CL	SPL CL				
614***	—	Flite-Flow	Flanged	*Pressure Seal	3 (80) thru 32 (800)
614Y	714Y	Flite-Flow	Butt Weld	*Pressure Seal	

\* 3 and 4 bolted bonnet with asbestos-free spiral-wound gasket.

\* Size 3 and 4 butt weld valves are Class 700.

### Dimensions – Flite-Flow®

Black numerals are in inches and pounds  
Colored numerals are in millimeters and kilograms

Figure No. 614Y/714Y, 614***	NPS	3	4	6	8	10	12	14	16	20	24	26	28	32
	DN	80	100	150	200	250	300	250	400	500	600	650	700	800
A <sub>1</sub> - End to End, (Welding)		13	15.5	20	26	31	38	38	41	60	66	70	81.5	90
		330	394	508	660	788	965	965	1041	1524	1676	1778	2070	2286
A <sub>2</sub> - Face to Face, (Flanged)		16.75	21.25	29	33	39	45	45	52	*	*	*	*	*
		425	540	737	838	991	1143	1143	1321					
E - Center to Top, (Open)		17.5	21.5	28.5	34	42	49	49	74	71	*	*	*	*
		445	546	724	864	1067	1245	1245	1880	1803				
G - Handwheel Diameter		12	14	16	20	26	30	30	48	48	*	*	*	*
		305	356	406	508	660	762	762	1219	1219				
Weight, (Welding)		110	150	450	850	1400	2050	2050	5500	9200	*	*	*	*
		50	68	204	385	635	930	930	2495	4173				
Weight, (Flanged)		150	240	570	1000	1800	2450	2550	6500	*	*	*	*	*
		68	109	259	454	816	1111	1157	2948					

\* Dimensions and information supplied upon request. \*\* Impactor handwheel standard on all Flite-Flow valves.

\*\*\* Flanged valves are available in sizes 3 through 16.

Refer to page 73 for materials of construction.

Refer to pages 203 through 238 for the applicable pressure ratings.

## Stop-Check (Non-Return) Valves, Class 600

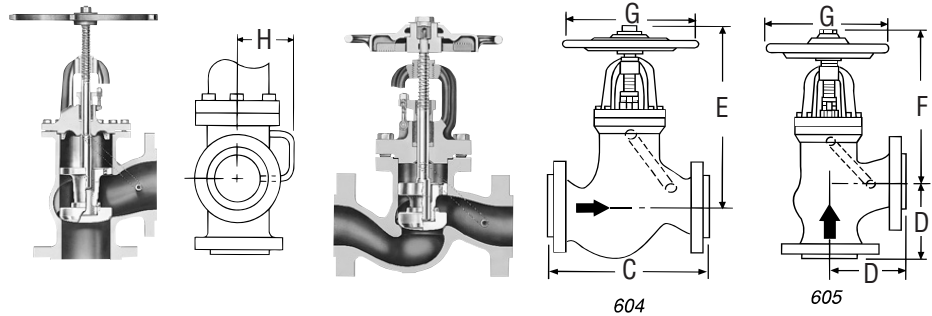

### Standard Features

- Bodies and bonnets are cast steel (WCB, WCC, WC9, CF8M)
- Bolted or pressure-seal bonnet OS & Y
- Globe or angle
- Integral Stellite seat, disc and backseat
- Body-guided disc piston
- 13% chromium stainless steel stem
- Asbestos-free graphitic packing
- Long terne<sup>®</sup> steel or composite pressure seal gasket
- Equipped with equalizer

### Pressure Class 600 (PN 110)

FIG. NO.		TYPE	ENDS	BONNET	NPS (DN)
STD CL	SPL CL				
604	—	Globe	Flanged	Bolted	2½ (65) thru 6 (150)
604Y	—	Globe	Butt Weld	Bolted	
605	—	Angle	Flanged	Bolted	
605Y	—	Angle	Butt Weld	Bolted	
606	—	Globe	Flanged	Pressure Seal	8 (200) thru 14 (350)
606Y	706Y	Globe	Butt Weld	Pressure Seal	
607	—	Angle	Flanged	Pressure Seal	8 (200) thru 14 (350), 24 (600), 28 (700) & 30 (750)
607Y	707Y	Angle	Butt Weld	Pressure Seal	

### Dimensions – Globe & Angle\*

Black numerals are in inches and pounds  
Colored numerals are in millimeters and kilograms

Figure No. 604/604Y, 605/605Y, 606/606Y, 607/607Y, 706Y, 707Y	NPS	2½	3	4	5	6	8	10	12	14
	DN	65	80	100	125	150	200	250	300	350
C - Face to Face, Globe**		13	14	17	20	22	26	31	33	35
		330	356	432	508	559	660	787	838	889
D - Center to Face, Angle**		6.5	7	8.5	10	11	13	15.5	16.5	17.5
		165	178	216	254	279	330	394	419	445
E - Center to Top, Globe		16.2	16.7	20.1	24.8	28.4	34.3	39.7	43.6	47
		411	424	511	630	721	871	1008	1107	1194
F - Center to Top, Angle		14.4	14.6	17.7	21.4	24.2	28.8	32.9	36.1	38.8
		366	371	450	544	615	731	836	917	986
G - Handwheel Diameter#		12	12	14	16	16	20	26	30	30
		305	305	356	406	406	508	660	762	762
H - Clearance for Equalizer		8.7	8.5	10	9.6	11	11.8	13	13.7	15.7
		221	216	254	244	279	300	330	348	399
Weight, Globe (Flanged)		110	135	220	425	540	960	1540	2200	2680
		50	61	112	193	245	435	699	998	1216
Weight, Globe (Welding)		84	110	185	335	410	750	1270	1850	2250
		38	50	84	152	186	340	596	839	1021
Weight, Angle (Flanged)		105	125	225	325	460	750	1200	1790	2150
		48	57	102	147	209	340	544	812	975
Weight, Angle (Welding)		80	90	168	245	350	560	950	1450	1760
		36	41	76	111	159	254	431	667	798

\* Angle valves only. Also available in sizes 24, 28 and 30. Dimensions available upon request. \*\* Center-to-end or end-to-end dimensions for welding and valves same as center to contact-face or contact-face-to-contact-face dimensions for flanged end valves. # Impactor handwheel is standard on all size valves. Refer to page 73 for materials of construction. Refer to pages 203 through 238 for the applicable pressure ratings.

## Stop-Check (Non-Return) Valves, Class 600

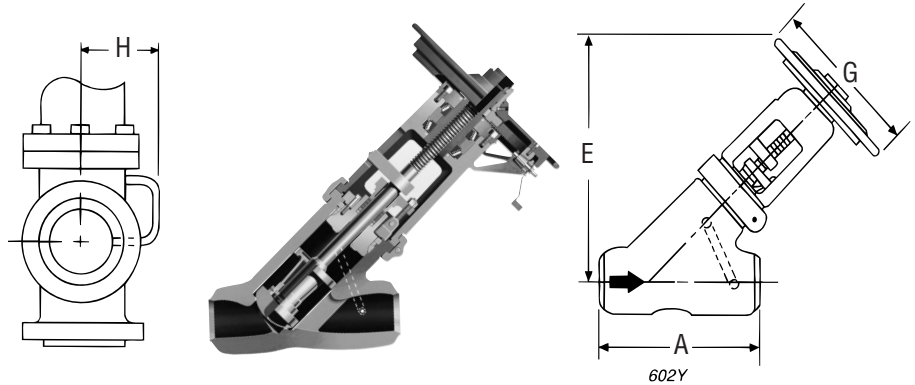

### Standard Features

- Bodies and bonnets are cast steel (WCB, WCC, WC9, CF8M)
- Bolted or pressure-seal bonnet, OS & Y
- Y Pattern
- Integral Stellite seat, disc and backseat
- Body-guided disc piston
- 13% chromium stainless steel stem
- Asbestos-free graphitic packing
- Spiral wound or composite pressure seal gasket
- Equipped with equalizer

### Pressure Class 600 (PN 110)\*

Fig. No.		Type	Ends	Bonnet	NPS (DN)
STD CL	SPL CL				
***602	—	Flite-Flow	Flanged	Pressure Seal*	3 (80) thru 32 (800)
602Y	702Y	Flite-Flow	Butt Weld	Pressure Seal*	

\* Size 3 & 4 - Bolted bonnet with asbestos-free spiral-wound gasket.

\* Size 3 & 4 Butt weld valves are Class 700.

### Dimensions – Flite-Flow®

Black numerals are in inches and pounds  
Colored numerals are in millimeters and kilograms

Figure No. 602Y/702Y, ***602	NPS	3	4	6	8	10	12	14	16	20	24	26	28	32
	DN	80	100	150	200	250	300	250	400	500	600	650	700	800
A1 - End to End, (Welding)		13	15.5	20	26	31	38	38	41	60	66	70	81.5	90
		330	394	508	660	787	965	965	1041	1524	1676	1778	2070	2286
A2 - Face to Face, (Flanged)		16.75	21.25	29	33	39	45	45	52	*	*	*	*	*
		425	540	737	838	991	1143	1143	1321					
E - Center to Top, (Open)		17.5	21.5	28.5	34	42	49	49	74	71	*	*	*	*
		445	546	724	864	1067	1245	1245	1880	1803				
G - Handwheel Diameter		12	14	16	20	26	30	30	48	48	*	*	*	*
		305	356	406	508	660	762	762	1219	1219				
H - Equalizer Clearance		7	9	10	12	13	14	14	22	24	*	*	*	*
		178	229	254	305	330	356	356	559	610				
Weight, (Welding)		110	150	450	850	1400	2050	2050	5500	9200	*	*	*	*
		50	68	204	385	635	930	930	2495	4173				
Weight, (Flanged)		150	240	570	1000	1800	2850	3100	6500	*	*	*	*	*
		68	109	259	454	816	1293	1406	2948					

\* E, G and other dimensions and information supplied upon request. \*\* Impactor handwheel standard on all Flite-Flow valves.

\*\*\* Flanged valves available in sizes 3 thru 16.

Refer to page 73 for materials of construction.

Refer to pages 203 through 238 for the applicable pressure ratings.

## Stop Valves, Class 900

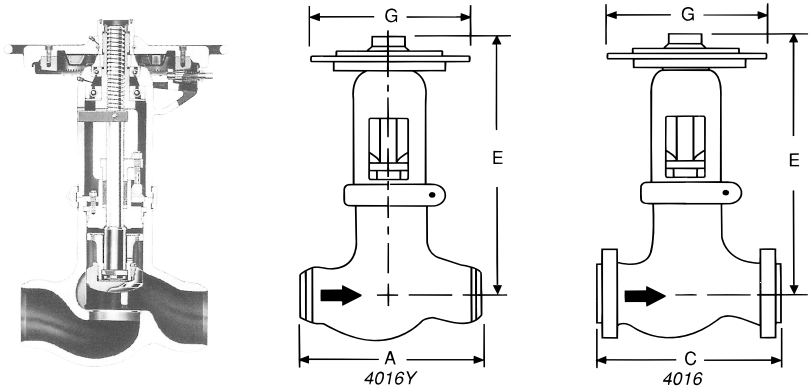

### Standard Features

- Bodies and bonnets are cast steel (WCB, WCC, WC9, CF8M)
- Pressure-seal bonnet, OS & Y
- Y Pattern, globe and angle design
- Integral Stellite seat, disc and backseat
- Body-guided disc piston
- 13% chromium stainless steel stem
- Asbestos-free graphitic packing
- Yoke bushing thrust bearings size 5 and larger

### Pressure Class 900 (PN 150)\*

Fig. No.		Type	Ends	NPS (DN)
STD CL	SPL CL			
4016	—	Globe	Flanged	3 (80) thru 14 (350)
4016Y	4316Y	Globe	Butt Weld	
4017	—	Angle	Flanged	3 (80) thru 24 (600)
4017Y	4317Y	Angle	Butt Weld	
4014	—	Flite-Flow	Flanged	3 (80) thru 16 (400)
4014Y	4314Y	Flite-Flow	Butt Weld*	

*Size 3 and 4 Butt weld Flite-Flow valves are class 1100.*

### Dimensions – Globe & Angle

Black numerals are in inches and pounds  
Colored numerals are in millimeters and kilograms

Figure No. 4016/4016Y, 4017/4017Y, 4316Y, 4317Y	NPS	3	4	5	6	8	10	12	14
	DN	80	100	125	150	200	250	300	350
A - End to End (Welding)		15	18	22	24	29	33	38	40.5
		381	457	559	610	737	838	965	1029
B - Center to Face (Welding)		7.5	9	11	12	14.5	16.5	19	19
		190	229	279	305	368	419	483	483
C - Face to Face (Flanged)		15	18	22	24	29	33	38	40.5
		381	457	559	610	737	838	965	1029
D - Center to Face (Flanged)		7.5	9	11	12	14.5	16.5	19	21.75
		190	229	279	305	368	419	483	552
E - Center to Top, Globe (Open)		22.5	26.25	30.6	37	46	54.75	64.75	71.25
		572	667	777	940	1168	1391	1645	1810
F - Center to Top, Angle (Open)		20.4	23.75	28.25	34.25	43.4	49.25	60	60
		518	603	718	870	1102	1251	1524	1524
G - Handwheel Diameter*		16	16	20	20	28	28	36	36
		406	406	508	508	711	711	914	914
Weight, Globe (Flanged)		210	310	610	800	1570	2410	3700	4600
		95	141	277	363	712	1093	1665	2086
Weight, Globe (Welding)		175	235	500	620	1390	2300	3100	3850
		79	107	227	281	630	1043	1395	1746
Weight, Angle (Flanged)		206	284	540	710	1360	2103	3010	3060
		93	129	245	322	612	946	1365	1388
Weight, Angle (Welding)		150	210	410	552	1035	1690	2555	2580
		68	95	185	250	466	761	1159	1170

\* Impactor handwheel is standard on all valves.  
Refer to page 73 for materials of construction.  
Refer to pages 203 through 238 for the applicable pressure ratings.



## Stop Valves, Class 900

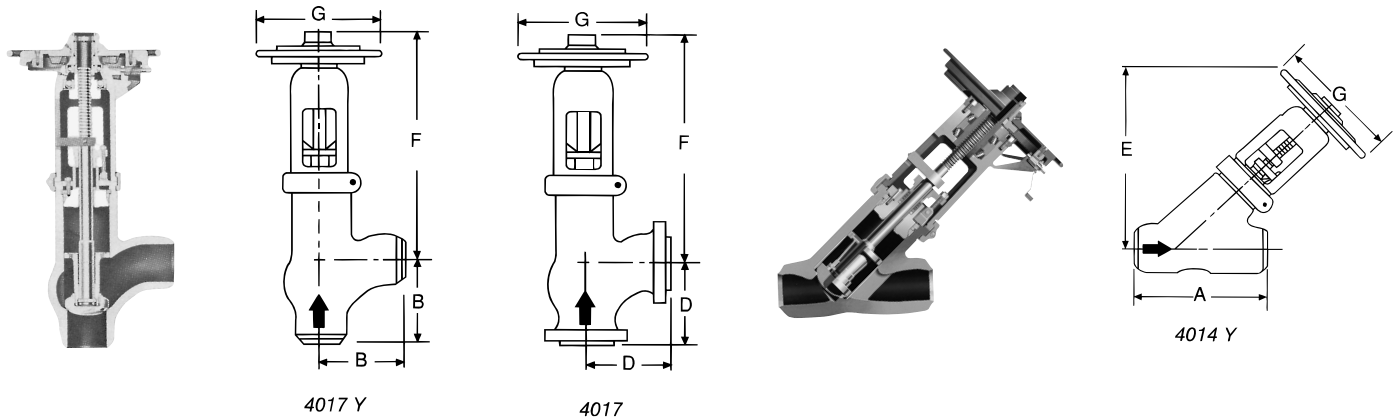

### Dimensions – Angle

Black numerals are in inches and pounds  
Colored numerals are in millimeters and kilograms

Figure No. 4017/4017Y, 4317Y	NPS	16	18	20	24
	DN	400	450	500	600
B - Center to End (Welding)		26	**	32.5	39
		660		825	991
F - Center to Top, Angle		78.5	**	95	102
		1994		2413	2591
G - Handwheel Diameter*		48	**	72	72
		1219		1829	1829
Weight, Angle (Welding)		4440	**	8150	13,750
		2014		3697	6237

\*\* Size 18 angle - available upon request.

### Dimensions – Flite-Flow®

Figure No. 4014/4014Y, 4314Y	NPS	3	4	6	8	10	12	14	16
	DN	80	100	150	200	250	300	350	400
A <sub>1</sub> - End to End (Welding)		17	18.5	20	26	31	38	38	44.5
		432	479	508	660	787	965	965	1130
A <sub>2</sub> - Face to Face (Flanged)		22.25	23.75	30	38	44	50	51	58
		565	603	762	965	1118	1270	1295	1473
E - Center to Top (Open)		20	25	35	44	51	60	60	73
		508	635	889	1118	1295	1524	1524	1854
G - Handwheel Diameter*		16	16	20	28	28	36	36	48
		406	406	508	711	711	914	914	1219
Weight (Welding)		190	275	550	1150	2100	3400	3400	5550
		86	125	249	522	953	1542	1542	2517
Weight (Flanged)		250	370	775	1550	2650	4150	4550	6950
		113	168	352	703	1202	1882	2064	3152

**Note:** Size 3 and 4 Butt-weld Class 900 Flite-Flow Valves are Class 1100. \*Impactor handwheel is standard on all valves.

Refer to page 73 for materials of construction.

Refer to pages 203 through 238 for the applicable pressure ratings.

## Stop-Check (Non-Return) Valves, Class 900

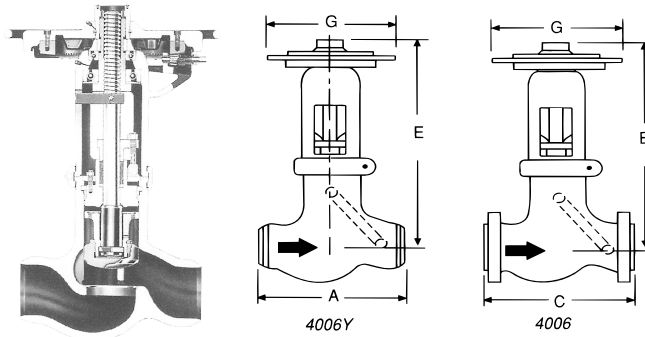

### Standard Features

- Bodies and bonnets are cast steel (WCB, WCC, WC9, CF8M)
- Pressure-seal Bonnet, OS & Y
- Y Pattern, globe and angle design
- Integral Stellite seat, disc and backseat
- Body-guided disc piston
- 13% chromium stainless steel stem
- Asbestos-free graphitic packing
- Equipped with equalizer
- Yoke bushing thrust bearings

### Pressure Class 900 (PN 150)\*

FIG. NO.		TYPE	ENDS	NPS (DN)
STD CL	SPL CL			
4006	—	Globe	Flanged	3 (80) thru 14 (350)
4006Y	4306Y	Globe	Butt Weld	
4007	—	Angle	Flanged	3 (80) thru 24 (600)
4007Y	4307Y	Angle	Butt Weld	
4002	—	Flite-Flow	Flanged	3 (80) thru 16 (400)
4002Y	4302Y	Flite-Flow	Butt Weld*	

\* Size 3 and 4 Butt weld Flite-Flow valves are Class 1100.

### Dimensions – Globe & Angle

Black numerals are in inches and pounds  
Colored numerals are in millimeters and kilograms

Figure No. 4006/4006Y, 4007/4007Y, 4306Y, 4307Y	NPS	3	4	5	6	8	10	12	14
	DN	80	100	125	150	200	250	300	350
A - End to End (Welding)		15	18	22	24	29	33	38	40.5
		381	457	559	610	737	838	965	1029
B - Center to End (Welding)		7.5	9	11	12	14.5	16.5	19	19
		190	229	279	305	368	419	483	483
C - Face to Face (Flanged)		15	18	22	24	29	33	38	40.5
		381	457	559	610	737	838	965	1029
D - Center to Face (Flanged)		7.5	9	11	12	14.5	16.5	19	21.75
		190	229	279	305	368	419	483	552
E - Center to Top, Globe (Open)		22.5	26.25	30.63	37	46	54.75	64.75	71.25
		572	667	778	940	1168	1391	1645	1810
F - Center to Top, Angle (Open)		20.38	23.75	28.25	34.25	43.38	49.25	60	62.75
		518	603	718	870	1102	1251	1524	1594
G - Handwheel Diameter*		16	16	20	20	28	28	36	36
		406	406	508	508	711	711	914	914
H - Clearance for Equalizer		7.5	7.63	9.75	10.75	12.5	12.88	14.75	17.38
		190	194	248	273	318	327	375	441
Weight, Globe (Flanged)		220	314	615	800	1570	2425	3700	4600
		100	142	279	363	712	1100	1665	2087
Weight, Globe (Welding)		175	245	500	642	1400	2300	3100	4750
		79	111	227	291	635	1043	1406	2155
Weight, Angle (Flanged)		206	284	540	690	1360	2103	3010	3060
		93	129	245	313	617	954	1365	1388
Weight, Angle (Welding)		150	215	410	552	1035	1600	2555	2580
		68	98	186	250	469	725	1159	1170

\* Impactor handwheel is standard on all valves.

Refer to page 73 for materials of construction.

Refer to pages 203 through 238 for the applicable pressure ratings.

## Stop-Check (Non-Return) Valves, Class 900

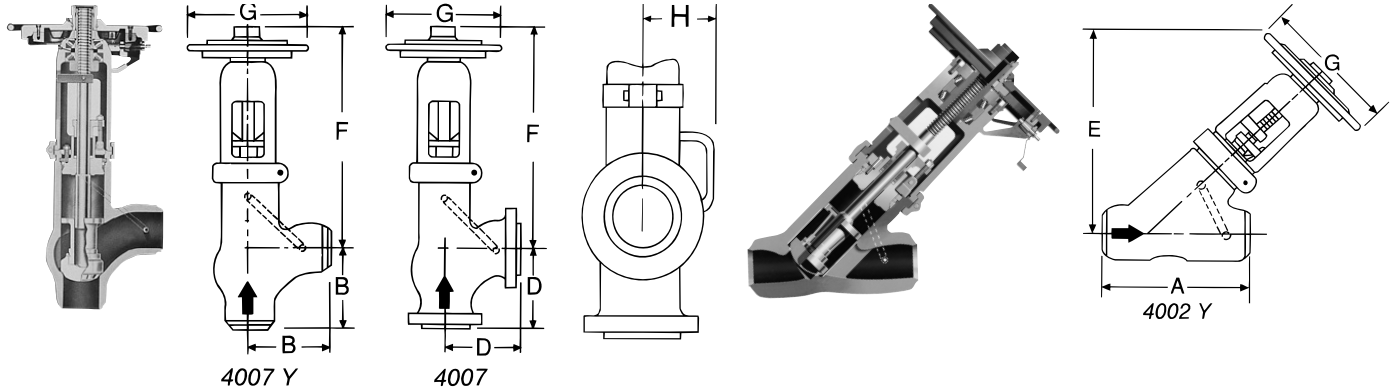

### Dimensions – Angle

Black numerals are in inches and pounds  
Colored numerals are in millimeters and kilograms

Figure No. 4007/4007Y, 4307Y	NPS	16	18	20	24
	DN	400	450	500	600
B - Center to End (Welding)		26	**	32.5	39
		660		825	991
F - Center to Top, Angle		78.5	**	95	102
		1994		2413	2591
G - Handwheel Diameter*		48	**	72	72
		1219		1829	1829
H - Clearance for Equalizer		20	**	21.5	30
		50.8		546	762
Weight, Angle (Welding)		4960	**	8150	13,750
		2250		3697	6237

\*\* Size 18" Angle - Available upon request.

### Dimensions – Flite-Flow

Figure No. 4002/4002Y, 4302Y	NPS	3	4	6	8	10	12	14	16
	DN	80	100	150	200	250	300	350	400
A <sub>1</sub> - End to End (Welding)		17	18.5	20	26	31	38	38	44.5
		432	470	508	660	787	965	965	1130
A <sub>2</sub> - Face to Face (Flanged)		22.25	23.75	30	38	44	50	51	58
		565	603	762	965	1118	1270	1295	1473
E - Center to Top (Open)		20	25	35	44	51	60	60	73
		508	635	889	1118	1295	1524	1524	1854
G - Handwheel Diameter*		16	16	20	28	28	36	36	48
		406	406	508	711	711	914	914	1219
H - Equalizer Clearance		9	9.3	10	12.5	16	15	15	25.75
		229	236	254	318	406	381	381	654
Weight (Welding)		190	275	555	1150	2100	3400	3400	5550
		86	125	252	522	953	1542	1542	2517
Weight (Flanged)		250	370	775	1550	2650	4150	4550	6950
		113	168	352	703	1202	1882	2064	3153

**Note:** Size 3 and 4 Butt-weld Class 900 Flite-Flow valves are Class 1100.

\* Impactor handwheel is standard on all valves.

Refer to page 73 for materials of construction.

Refer to pages 203 through 238 for the applicable pressure ratings.

## Stop Valves, Class 1500

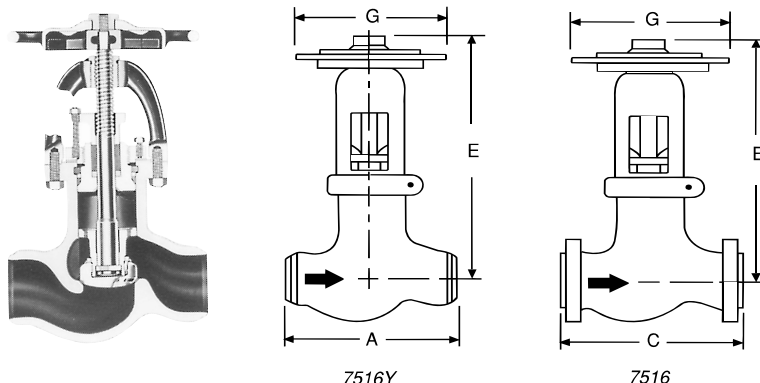

### Standard Features

- Bodies and bonnets are cast steel (WCB, WCC, WC9, CF8M)
- Pressure-seal bonnet, OS & Y
- Y Pattern, globe and angle design
- Integral Stellite seats and backseat
- Body-guided disc piston
- 13% chromium stainless steel stem
- Asbestos-free graphitic packing
- Yoke bushing thrust bearings size 5 and larger

### Pressure Class 1500 (PN 260)\*

Fig. No.		Type	Ends	NPS (DN)
STD CL	SPL CL			
7514Y	2014Y	Flite-Flow	Butt Weld*	3 (80) thru 24 (600)
7516	—	Globe	Flanged	2½ (65) thru 14 (350)
7516Y	2016Y	Globe	Butt Weld	
7517	—	Angle	Flanged	2½ (65) thru 24 (600)
7517Y	2017Y	Angle	Butt Weld	

### Dimensions – Globe & Angle

Black numerals are in inches and pounds  
Colored numerals are in millimeters and kilograms

Figure No. 7516/7516Y, 2016Y 7517/7517Y, 2017Y	NPS	2½	3	4	5	6	8	10	12	14
	DN	65	80	100	125	150	200	250	300	350
A - End to End (Welding)		13	15	18	22	24	29	33	38	40.5
		330	381	457	559	610	737	838	965	1029
B - Center to End (Welding)		6.5	7.5	9	11	12	14.5	16.5	19	20.25
		165	190	229	279	305	368	419	483	514
C - End to End (Flanged)		16.5	18.5	21.5	26.5	27.75	32.75	39	44.5	49.5
		419	470	546	673	705	832	991	1130	1257
D - Center to End (Flanged)		8.25	9.25	10.75	13.25	13.88	16.38	19.5	22.25	24.75
		210	235	273	337	353	416	495	565	629
E - Center to Top, Globe (Open)		19.25	22.5	26.25	30.63	36.5	48.75	59.5	70	70
		489	572	667	778	927	1238	1511	1778	1778
F - Center to Top, Angle (Open)		18	20.4	23.75	28.25	34.75	45.75	56	66.3	66.75
		457	518	603	718	883	1162	1422	1684	1695
G - Handwheel Diameter*		14	16	16	20	20	28	36	36	48
		356	406	406	508	508	711	914	914	1219
Weight, Globe (Flanged)		167	260	385	760	960	1800	3150	4910	5900
		76	118	175	345	435	816	1429	2227	2676
Weight, Globe (Welding)		90	175	270	525	700	1620	2600	3710	4850
		41	79	122	238	317	735	1179	1683	2200
Weight, Angle (Flanged)		153	230	330	730	865	1580	2780	4100	4850
		69	104	150	331	392	717	1261	1860	2200
Weight, Angle (Welding)		80	150	255	510	670	1250	2200	2900	3800
		36	68	116	231	304	567	998	1315	1724

\*Impactor handle is standard on size 2½ Globe and Angle valves. \*Impactor handwheel is standard on all other size Globe and Angle valves and all Flite-Flow valves. \*Impactogear is available on size 8 and larger Globe, Angle and Flite-Flow valves.

Refer to page 73 for materials of construction.

Refer to pages 203 through 238 for the applicable pressure ratings.

## Stop Valves, Class 1500

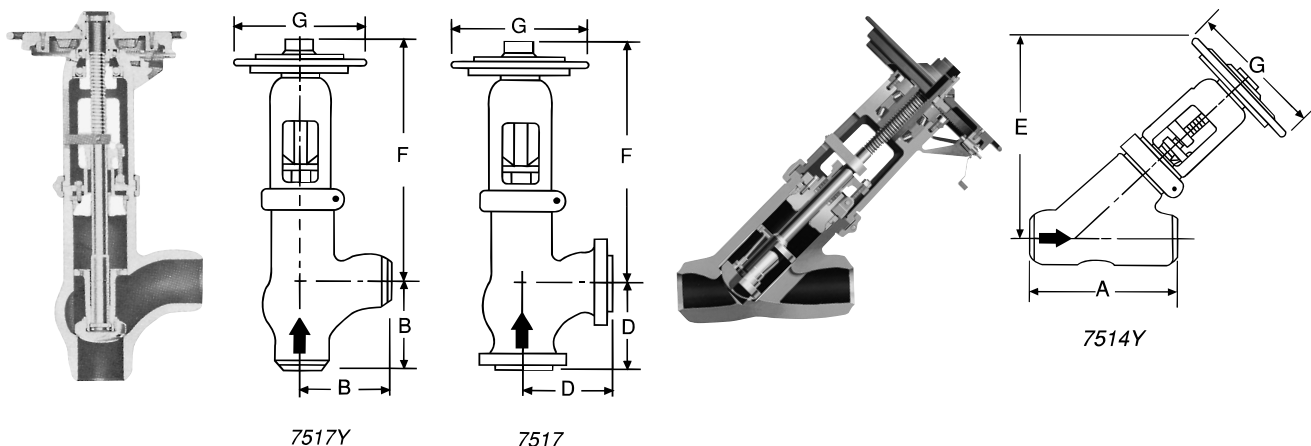

### Dimensions – Globe & Angle

Black numerals are in inches and pounds  
Colored numerals are in millimeters and kilograms

Figure No. 7517/7517Y, 2017Y	NPS	16	18	20	24
	DN	400	450	500	600
B - Center to End (Welding)		23.5	23.5	28.5	35.5
		597	597	724	902
F - Center to Top, Angle		77.5	77.5	84	103
		1969	1969	2134	2616
G - Handwheel Diameter*		48	48	72	72
		1219	1219	1829	1829
Weight, Angle (Welding)		6600	6800	9500	16,200
		2994	3084	4309	7348

### Dimensions – Flite-Flow®

Figure No. 7514Y/2014Y	NPS	3	4	6	8	10	12	14	16	18	20	24
	DN	80	100	150	200	250	300	350	400	450	500	600
A - End to End (Welding)		17	18.5	27.75	30	36.25	43	41	54	63	54.5	59.5
		432	470	705	762	921	1092	1041	1372	1600	1384	1511
E - Center to Top (Open)		20	25	34.25	45	53.5	60.75	60.75	78.5	78.5	96	96
		508	635	870	1143	1359	1543	1543	1994	1994	2438	2438
G - Handwheel Diameter*		16	16	20	28	36	36	36	48	48	72	72
		406	406	508	711	914	914	914	1219	1219	1829	1829
Weight (Welding)		210	300	700	1550	2725	4220	4300	7650	8390	10,500	16,800
		95	136	318	702	1236	1914	1950	3470	3806	4763	7620

Notes: Size 3 and 4 Butt-weld Class 1500 Flite-Flow valves are Class 1800.

\*Impactor handle is standard on size 2½ Globe and Angle valves. \*Impactor handwheel is standard on all other size Globe and Angle valves and all Flite-Flow valves. \*Impactogear is available on size 8 and larger Globe, Angle and Flite-Flow valves.

Refer to page 73 for materials of construction.

Refer to pages 203 through 238 for the applicable pressure ratings.

## Stop-Check (Non-Return) Valves, Class 1500

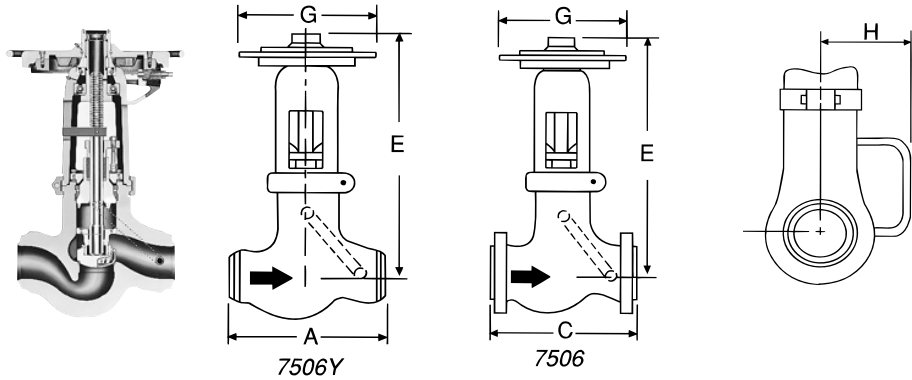

### Standard Features

- Bodies and bonnets are cast steel (WCB, WCC, WC9, CF8M)
- Pressure-seal bonnet, OS & Y
- Y Pattern, globe or angle design
- Integral Stellite seats and backseat
- Body-guided disc piston
- 13% chromium stainless steel stem
- Asbestos-free graphitic packing
- Equipped with equalizer
- Yoke bushing thrust bearings size 5 and larger

### Pressure Class 1500 (PN 260)\*

FIG. NO.		TYPE	ENDS	NPS (DN)
STD CL	SPL CL			
7502Y	2002Y	Flite-Flow	Butt Weld*	3 (80) thru 24 (600)
7506	—	Globe	Flanged	2½ (65) thru 14 (350)
7506Y	2006Y	Globe	Butt Weld	
7507	—	Angle	Flanged	2½ (65) thru 24 (600)
7507Y	2007Y	Angle	Butt Weld	

\* Size 3 and 4 Buttweld Flite-Flow valves are Class 1800.

### Dimensions – Globe & Angle

Black numerals are in inches and pounds  
Colored numerals are in millimeters and kilograms

Figure No. 7506/7506Y, 7507/7507Y, 2006Y, 2007Y	NPS DN	2½	3	4	5	6	8	10	12	14
A - End to End (Welding)	65	80	100	125	150	200	250	300	350	
	13	15	18	22	24	29	33	38	40.5	
	330	381	457	559	610	737	838	965	1029	
B - Center to End (Welding)	6.5	7.5	9	11	12	14.5	16.5	19	20.25	
	165	190	229	279	305	368	419	483	514	
C - Face to Face (Flanged)	16.5	18.5	21.5	26.5	27.75	32.75	39	44.5	49.5	
	419	470	546	673	705	832	991	1130	1257	
D - Center to Face (Flanged)	8.25	9.25	10.75	13.25	13.88	16.38	19.5	22.25	24.75	
	210	235	273	337	353	416	495	565	628	
E - Center to Top, Globe	19.25	22.5	26.25	30.63	36.5	48.75	59.5	70	70	
	489	572	667	778	927	1238	1511	1778	1778	
F - Center to Top, Angle	18	20.38	23.75	28.25	34.75	45.75	56	66.3	66.75	
	457	518	603	718	883	1162	1422	1684	1695	
G - Handwheel Diameter*	14	16	16	20	20	28	36	36	48	
	356	406	406	508	508	711	914	914	1219	
H - Clearance for Equalizer	6.75	7.75	7.75	10	10.75	12.75	14	15	17.38	
	171	197	197	254	273	324	356	381	441	
Weight, Globe (Flanged)	167	270	385	770	960	1800	3150	4910	5900	
	76	122	175	349	435	816	1429	2227	2676	
Weight, Globe (Welding)	90	180	270	570	710	1470	2600	3710	4850	
	41	82	122	258	322	667	1179	1683	2200	
Weight, Angle (Flanged)	153	230	330	730	865	1580	2780	4100	4850	
	69	104	149	331	392	717	1261	1860	2200	
Weight, Angle (Welding)	77	160	255	510	585	1250	2200	2900	3800	
	35	73	116	231	265	567	998	1315	1724	

\*Impactor handle is standard on size 2½ Globe and Angle valves. \*Impactor handwheel is standard on all other size Globe and Angle valves and all Flite-Flow valves. \*Impactogear is available on size 8 and larger Globe, Angle and Flite-Flow valves.

Refer to page 73 for materials of construction.

Refer to pages 203 through 238 for the applicable pressure ratings.

## Stop-Check (Non-Return) Valves, Class 1500

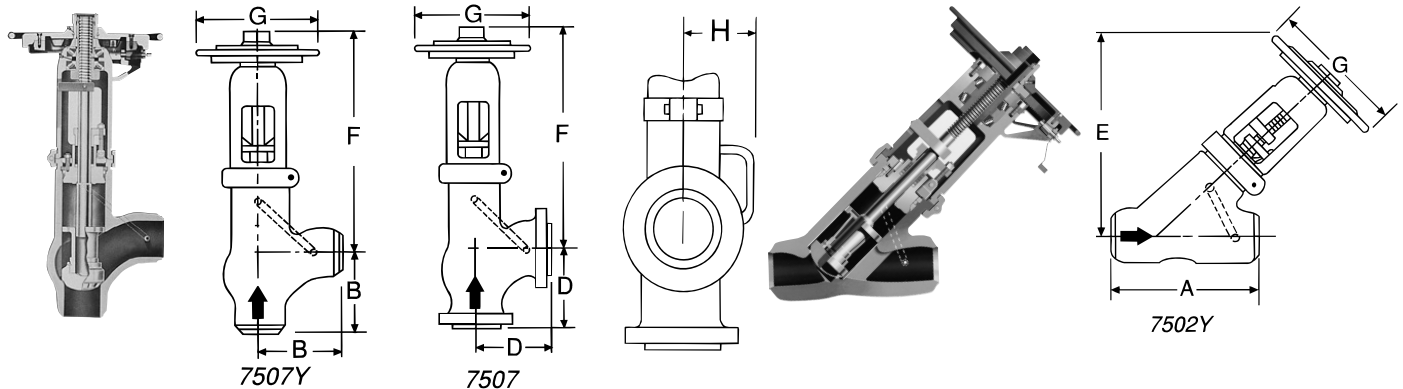

### Dimensions – Angle

Black numerals are in inches and pounds  
Colored numerals are in millimeters and kilograms

Figure No. 7507/7507Y, 2007Y	NPS	16	18	20	24
	DN	400	450	500	600
B - Center to End (Welding)		23.5	23.5	28.5	35.5
		597	597	724	902
F - Center to Top, Angle		77.5	77.5	84	103
		1969	1969	2134	2616
G - Handwheel Diameter*		48	48	72	72
		1219	1219	1829	1829
H - Clearance for Equalizer		19.5	19.5	23	28.5
		495	495	584	724
Weight, Angle (Welding)		6600	6800	9500	16,200
		2994	3084	4309	7348

### Dimensions – Flite-Flow

Figure No. 7502Y, 2002Y	NPS	3	4	6	8	10	12	14	16	18	20	24
	DN	80	100	150	200	250	300	350	400	450	500	600
A - End to End (Welding)		17	18.5	27.75	30	36.25	43	41	54	63	54.5	59.5
		432	470	705	762	921	1092	1041	1372	1600	1384	1511
E - Center to Top		20	25	34.25	45	53.5	60.75	60.75	78.5	78.5	96	96
		508	635	870	1143	1359	1543	1543	1994	1994	2438	2438
G - Handwheel Diameter*		16	16	20	28	36	36	36	48	48	72	72
		406	406	508	711	914	914	914	1219	1219	1829	1829
H - Equalizer Clearance		9	10	10.75	12.75	15.75	16.5	16.5	19.5	19.5	28	28
		229	254	273	324	400	419	419	495	495	711	711
Weight (Welding)		210	300	720	1600	2820	4260	4280	8450	8400	10,500	11,500
		95	136	327	726	1279	1932	1941	3833	3810	4763	5216

**Note:** Size 3 and 4 Butt-weld Class 1500 Flite-Flow valves are Class 1800.

\*Impactor handle is standard on size 2½ Globe and Angle valves. \*Impactor handwheel is standard on all other size Globe and Angle valves and all Flite-Flow valves. \*Impactogear is available on size 8 and larger Globe, Angle and Flite-Flow valves.

Refer to page 73 for materials of construction.

Refer to pages 203 through 238 for the applicable pressure ratings.

---

Page intentionally left blank



## **Anchor/Darling Globe Valves**

## Features and Description of Anchor/Darling 800 Series Globe Valves

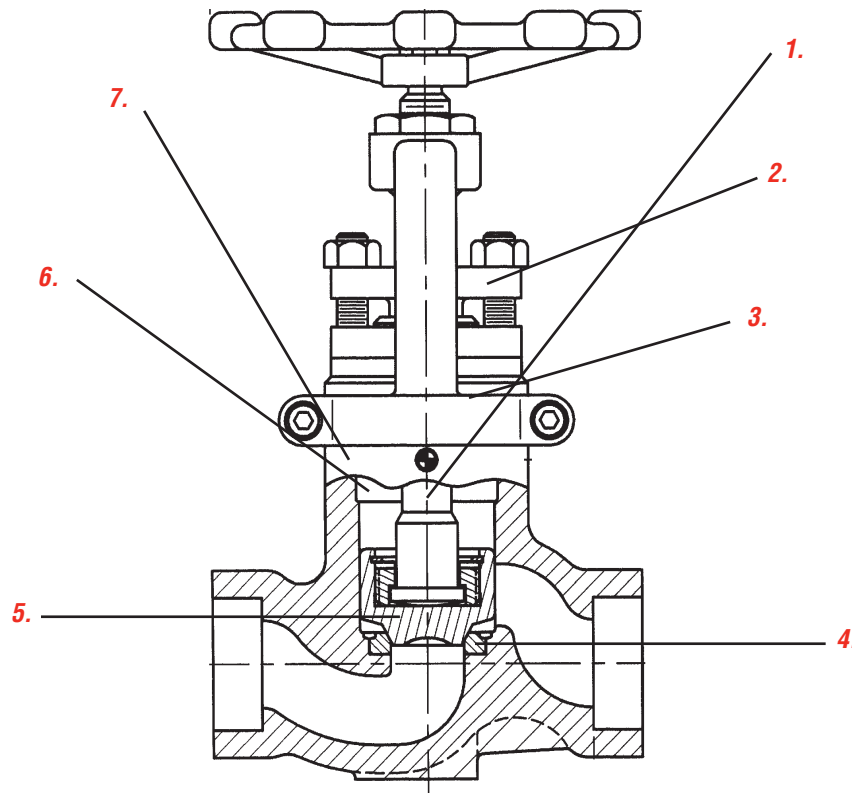

- |  |  |   |
|--|--|---|
| <p><b>1. Oversized stem</b> provides stronger disc-to-stem connection and reduces packing wear through increased stiffness.</p> <p><b>2. Graphite stem</b> packing provides better sealing and longer packing life.</p> <p><b>3. ADVanseal pressure</b> sealing system eliminates leakage, reduces maintenance and is more cost effective.</p> | <p><b>4. Seat ring</b> is solid, hardened material (Stellite or non-Cobalt) and is fully shouldered and brazed in place.</p> <p><b>5. Disc</b> is body guided and solid hardened material (Stellite or non-Cobalt).</p> <p><b>6. Machined backseat</b> provides additional packing protection.</p> | <p><b>7. Investment cast body</b> produces a smooth flow transition, minimizes flow turbulence resulting in higher Cv's. Pressure seal bonnet eliminates leakage.</p> |
|--|--|---|

## Parts Specification List for Anchor/Darling 800 Series Globe Valves

### Standard Features

- Available body material  
SA216-WCB  
SA351-CF8M
- Investment cast for smooth flow
- Rising stem design
- One-piece body and bonnet

**Anchor/Darling 800 Series globe valves for nuclear service are normally furnished in Class 800. Other interpolated pressure classes are also available on application.**

Parts shown are not applicable to all 800 Series valves. Construction and materials for nuclear valves may vary depending upon customer design specifications. For a complete, accurate and itemized description of a particular valve, contact your local Flowserve valves sales representative.

Description	ASME/ASTM No.	ASME/ASTM No.
<b>Body</b>	SA216-WCB	SA351-CF8M
<b>Stem</b>	A564-630-1075	A564-630-1075
<b>Disc</b>	SA564-630-1075	SA564-630-1075
<b>Seat</b>	A276-S21800A	A276-S21800A
<b>End Rings</b>	Braided Graphite	Braided Graphite
<b>Packing Rings</b>	Grafoil	Grafoil
<b>Gland Retainer</b>	A564-630-1075	A564-630-1075
<b>Gland Adjusting Screw</b>	AISI 300	AISI 300
<b>Yoke Bushing</b>	B21-C464-H02	B21-C464-H02
<b>Handwheel</b>	A351-CF8M	A351-CF8M
<b>Stem Nut</b>	A194-2H	A194-2H

## 800 Series Stop Valves – T Pattern, Class 800

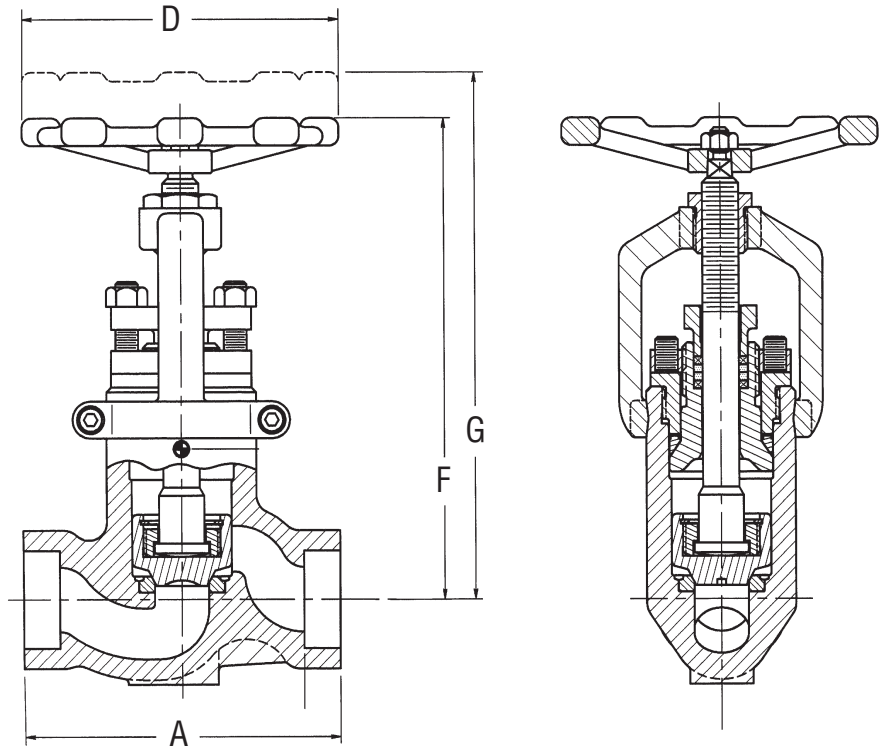

### Features

- Pressure Class 800 (Intermediate) (WCB, CF8M)
- Investment cast body
- Body-guided solid hard-faced disc; non-cobalt standard
- Non-cobalt seat ring; standard
- Oversized stem
- ADVanseal® pressure seal
- Machined backseat

### Pressure Class 800 (PN 130)

Fig. No.	Type	Ends	NPS (DN)
UGB24S	Globe	Socket Weld	½ (15) thru 2 (50)
UGB24U	Globe	Butt Weld	½ (15) thru 2 (50)

### Dimensions – Globe

Black numerals are in inches and pounds  
Colored numerals are in millimeters and kilograms

Figure No. UGB24S/UGB24U	NPS	½	¾	1	1½	2
	DN	15	20	25	40	50
A		3.7	3.7	4.8	6.3	7.0
		94	94	122	160	178
D		3.0	3.0	4.0	6.0	9.0
		76	76	102	152	229
F		5.4	5.4	6.9	8.3	9.4
		137	137	175	211	239
G		5.8	5.8	7.4	9.0	10.4
		147	147	188	229	264
Weight Approx (lbs.)		4.0	4.0	6.0	13.0	20.0
		1.8	1.8	2.7	5.9	9.1
Cv		4.5	4.5	8	22	36

Refer to page 91 for materials of construction.

Refer to pages 203 through 238 for the applicable pressure ratings.

## 800 Series Stop Valves – T Pattern, Class 800

### Features

- Pressure Class 800 (Intermediate) (WCB, CF8M)
- Investment cast body
- ADVanseal® body-bonnet sealing
- Secondary stem seal
  - Backseat
  - Stem packing
- Long bellows life
  - Per MSS-SP-117
  - 300 SS Bellows material
- Non-rotating stem

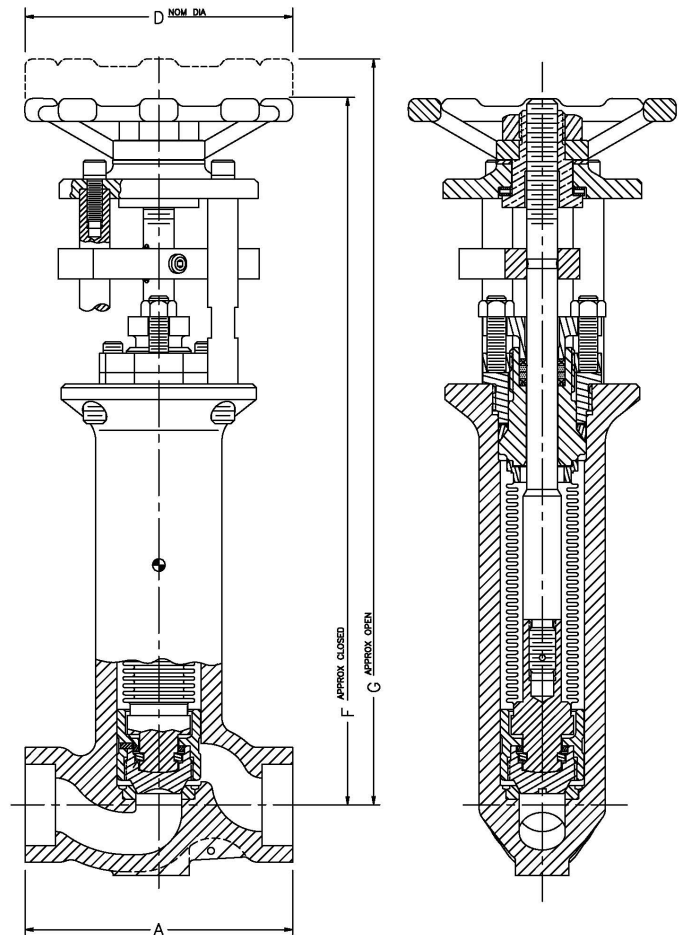

### Pressure Class 800 (PN 130)

Fig. No.	Type	Ends	NPS (DN)
UBG245	Globe	Socket Weld	½ (15) thru 2 (50)
UBG24U	Globe	Butt Weld	½ (15) thru 2 (50)

### Dimensions – Globe

Black numerals are in inches and pounds  
Colored numerals are in millimeters and kilograms

Figure No. UGB24S/UGB24U	NPS	½	¾	1	2
	DN	15	20	25	50
A		4.4	4.4	4.4	7
D		4	4	4	9
F		11.6	11.6	11.6	17.4
G		12.1	12.1	12.1	18
Weight Approx (lbs.)		11	11	11	35
Cv		4	7	8	22

Refer to page 91 for materials of construction.  
Refer to pages 203 through 238 for the applicable pressure ratings.

## Features and Description of 1878 Series Globe Valve

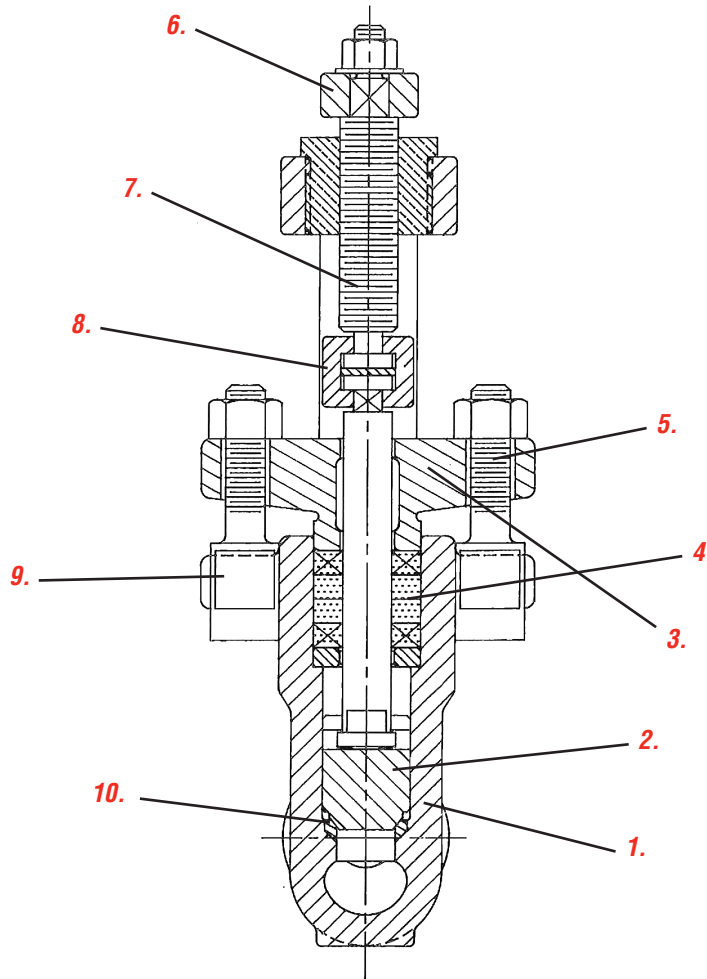

### Standard Valve Features

1. **A one-piece rugged**, low-profile, precision cast body/yoke assembly, manufactured using the latest investment casting techniques, offering smooth flow passages, not available with forged body valves.
2. **Four distinct disc styles** are offered either from the factory or easily field-converted from customer inventory.
  - A. Quick-open plug type
  - B. Parabolic
  - C. Cage type

A circular plate below the handwheel nut indicates the type of disc.
3. **A sturdy self-aligning gland flange** ensures positive loading of the packing and sealing integrity.
4. **Expanded graphite packing** with braided graphite end rings is standard. Live loaded packing is available as an option.
5. **Large packing gland bolts** provide positive sealing and are easily removed for service.
6. **The T-handle** is made of stainless steel and can be locked open or closed, if necessary. The 2" full ported valves use an impactor T-handle.
7. **A large-diameter upper stem** is utilized to provide ease of operation and is everlubed to minimize friction.
8. **A stem clamp** couples the rotating upper stem with the non-rotating lower stem and also serves as a position indicator.
9. **The lower non-rotating stem** provides greater packing longevity than valves using rotating stems and has a T-head design, allowing ease of disc removal. Other competitive valves offering a stem-disc assembly are more costly and difficult to service.
10. **The seat ring** is non-Cobalt material that is furnace blazed into the body using a high-temperature nickel alloy. The disc is non-Cobalt material and is fully body-guided for proper seat alignment. Optional Cobalt-based seat and disc materials are available on special order.

## Parts Specification List for Anchor/Darling 1878 Series Globe Valves

### Standard Features

- Available body material  
SA216-WCB  
SA351-CF8M
- Investment cast for smooth flow
- Integrated body and bonnet
- T and Y patterns
- Integrated body and bonnet

**Anchor/Darling 1878 Series globe valves for nuclear service are normally furnished in Class 1878. Other interpolated pressure classes are also available on application.**

Parts shown are not applicable to all 1878 Series valves. Construction and materials for nuclear valves may vary depending upon customer design specifications. For a complete, accurate and itemized description of a particular valve, contact your local Flowserve valves sales representative.

Description	ASME/ASTM No.	ASME/ASTM No.
<b>Body</b>	SA216-WCB	SA351-CF8M
<b>Stem</b>	A564-630-1075	A564-630-1075
<b>Disc</b>	A747-CB7-CU1-H1100	A747-CB7-CU1-H1100
<b>Seat</b>	A276-S21800A	A276-S21800A
<b>End Rings</b>	Braided Graphite	Braided Graphite
<b>Packing Rings</b>	Grafoil	Grafoil
<b>Gland</b>	A351-CF8M	A351-CF8M
<b>Gland Adjusting Screw</b>	A564-630-1075	A564-630-1075
<b>Yoke Bushing</b>	B21-C464-H02	B21-C464-H02
<b>Handle</b>	A351-CF8M	A351-CF8M
<b>Stem Nut</b>	A1S1 300	A1S1 300

## Series 1878 Stop Valves, Class 1878

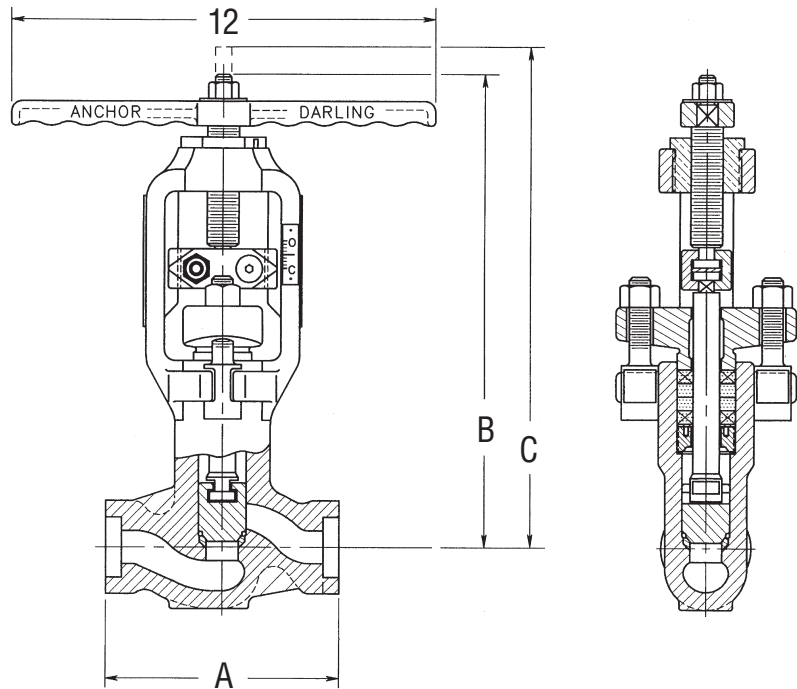

### Features

- Pressure Class 1878 (Intermediate) (WCB, CF8M)
- One-piece investment cast body/yoke
- T-head stem for easy changeout of disc
- Four disc styles:
  - Quick Opening
  - Equal Percent
  - Linear
  - Resilient
- Bore-guided disc

### Pressure Class 1878 (PN 325)

Fig. No.	Type	Ends	NPS (DN)
NGB24S	Globe	Socket Weld	½ (15) thru 2 (50)
NGB24U	Globe	Butt Weld	½ (15) thru 2 (50)

- Non-rotating stem
- Ease of maintenance
- Graphite packing standard
- Removable threaded backseat or loose backseat
- Non-cobalt seating standard
- Integral position indicator

### Dimensions – Globe

Black numerals are in inches and pounds  
Colored numerals are in millimeters and kilograms

Figure No. NGB24S/NGB24U	NPS	½	¾	1	1½	2*	2
	DN	15	20	25	40	50	50
A		5.5	5.5	5.5	7.0	8.5	8.5
		140	140	140	178	216	216
B		10.8	10.8	10.8	13.7	13.7	16.6
		274	274	274	348	348	422
C		11.5	11.5	11.5	14.7	14.7	17.8
		292	292	292	373	373	452
Weight Approx (lbs.)		16	16	16	33	35	55
		7.3	7.3	7.3	15.0	15.9	25
Cv**		7	8	8	24	24	38

\* Reduced ports \*\* Quick open – Flow under disc  
Refer to page 95 for materials of construction.  
Refer to pages 203 through 238 for the applicable pressure ratings.



## Series 1878 Stop Valves, Class 1878

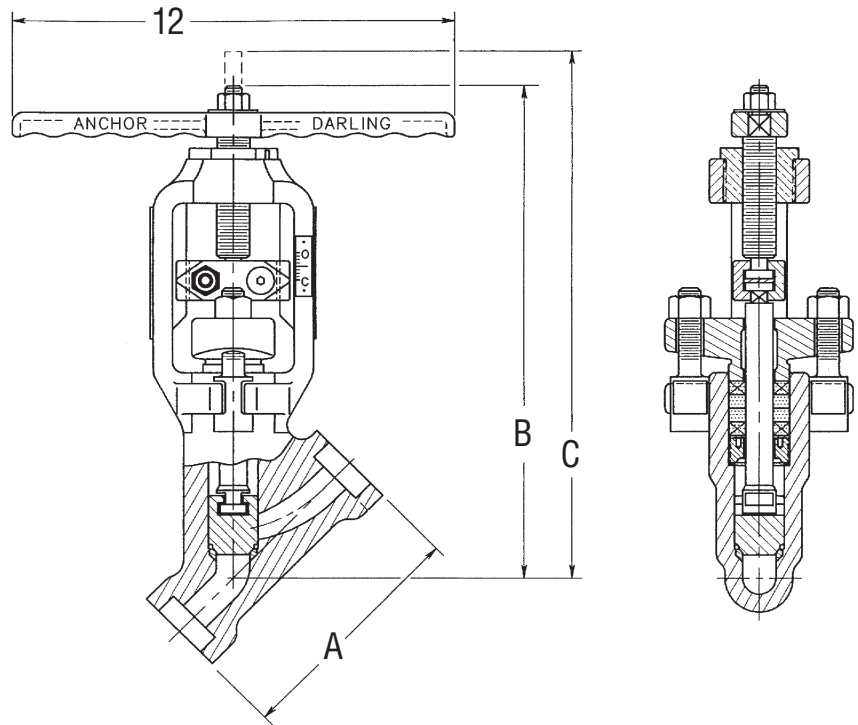

### Features

- Pressure Class 1878 (Intermediate) (WCB, CF8M)
- One-piece investment cast body/yoke
- Four disc styles:
  - Quick Opening
  - Equal Percent
  - Linear
  - Resilient
- T-head stem for easy changeout of disc
- Bore-guided disc
- Integral position indicator

### Pressure Class 1878 (PN 260)

Fig. No.	Type	Ends	NPS (DN)
NYG34S	Y Globe	Socket Weld	½ (15) thru 2 (50)
NYG34U	Y Globe	Butt Weld	½ (15) thru 2 (50)

- Non-rotating stem
- Ease of maintenance
- Graphite packing standard
- Removable threaded backseat or loose backseat
- Non-cobalt seating standard

### Dimensions – Globe

Black numerals are in inches and pounds  
Colored numerals are in millimeters and kilograms

Figure No. NYG34S/NYG34U	NPS	½	¾	1	1½	2*	2
	DN	15	20	25	40	50	50
A		5.5	5.5	5.5	7.0	8.5	8.5
		140	140	140	178	216	216
B		11.3	11.3	11.3	14.3	14.3	17.3
		274	274	224	348	348	422
C		11.9	11.9	11.9	15.3	15.3	18.5
		292	292	292	373	373	452
Weight Approx (lbs.)		16	16	16	33	35	55
		7.3	7.3	7.3	15	15.9	25
Cv**		14	16	16	48	48	76

\* Reduced ports \*\* Quick open – Flow under disc  
Refer to page 95 for materials of construction.  
Refer to pages 203 through 238 for the applicable pressure ratings.

## Series 1878 Stop Valves – Y Pattern Bellows Seal, Class 1878

Also available in series 800.

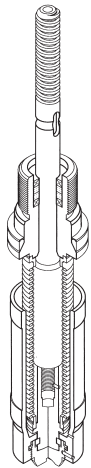

Rapid Change Kit

### Rapid Change Kit

The Rapid Change Kit includes trim parts, the ADVanseal® Pressure Seal Gasket, bellows and disc assembly, and is offered as a means for keeping the time to repair or refurbish trim components to a minimum and thereby help to minimize exposure time of maintenance personnel.

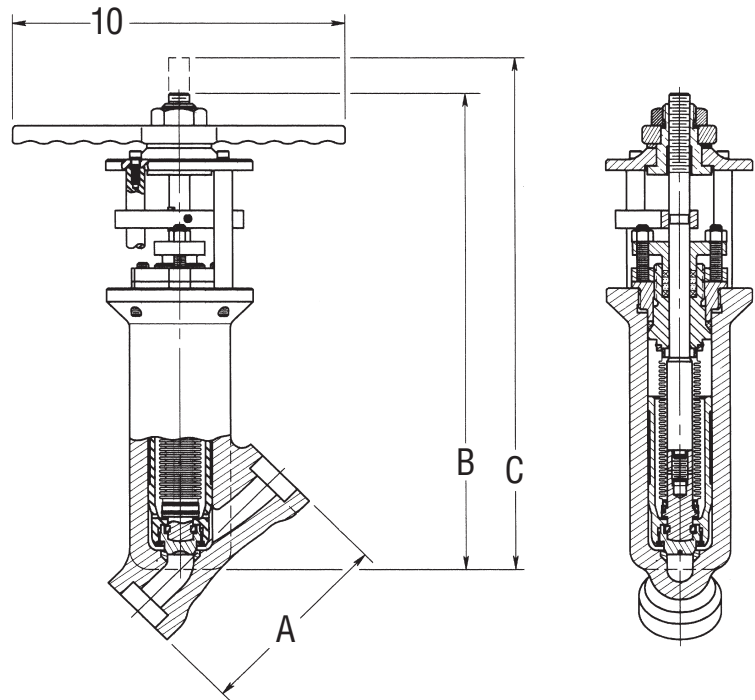

### Features

- Pressure Class 1878 (Intermediate) (WCB, CF8M)
- Investment cast body
- ADVanseal® body-bonnet sealing
- Secondary stem seal:
  - Backseat
  - Stem packing
- Long bellows life
  - Per MSS-SP-117
- Non-rotating stem

### Pressure Class 1878 (PN 260)

Fig. No.	Type	Ends	NPS (DN)
NBG34S	Globe	Socket Weld	½ (15) thru 1 (25)
NBG34U	Globe	Butt Weld	½ (15) thru 1 (25)

- Quick-opening disc
- Ease of maintenance
  - No welding design
  - Rapid Change Kit
- Non-cobalt seating standard

### Dimensions – Globe

Black numerals are in inches and pounds  
Colored numerals are in millimeters and kilograms

Figure No. NBG34S/NBG34U	NPS	½	¾	1
	DN	15	20	25
A		5.5	5.5	5.5
		140	140	140
B		13.8	13.8	13.8
		351	351	351
C		14.1	14.1	14.1
		358	358	358
Weight Approx (lbs.)		21	21	21
		9.5	9.5	9.5
Cv		8	9	9

Other sizes available upon request.  
Refer to page 95 for materials of construction.  
Refer to pages 203 through 238 for the applicable pressure ratings.

## Series 1878 Instrument Valves – T Pattern, Class 1878

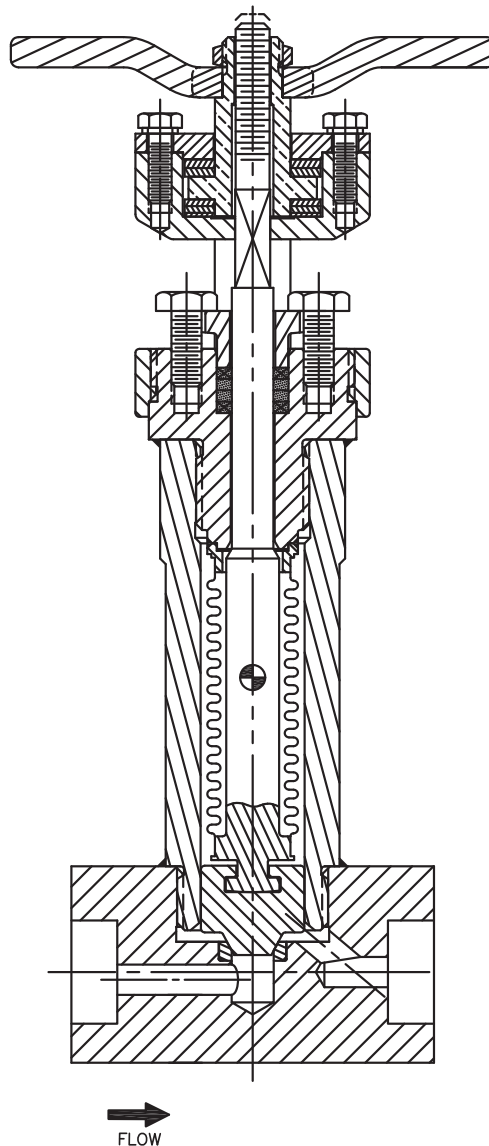

### Features

- Seat is cold-formed into body recess
- Bellows is two-ply Inconel 625 for increased strength and cycle life (per MSS-SP-117)
- Secondary packing seal provides backup sealing in case of bellows leakage
- Bonnet is threaded and seal welded to body to eliminate leak path
- Yoke adapter is equipped with bearings for easy operation at high pressure

Consult your Flowserve sales representative for materials of construction.  
Refer to pages 203 through 238 for the applicable pressure ratings.

### Pressure Class 1878 (PN 260)

Fig. No.	Type	Ends	NPS (DN)
NGI29S	Instrument Globe	Socket Weld	½ (15) thru 1 (25)
NGI29U	Instrument Globe	Butt Weld	½ (15) thru 1 (25)

- Available sizes – 1/2", 3/4" and 1"
- Weight – 5 1/2 pounds
- C<sub>v</sub> – 1

## Features and Description of Flowserve Anchor/Darling Globe Valves

Various body types are offered to provide the piping designer greater flexibility. The Y globe and horizontal globe are normally used in horizontal pipelines. The angle globe is normally used in lieu of an elbow where flow control is necessary and when flow is upward in the vertical piping leg. The Y angle globe is normally used in lieu of an elbow where flow control is necessary and when flow is toward the valve in the horizontal piping leg.

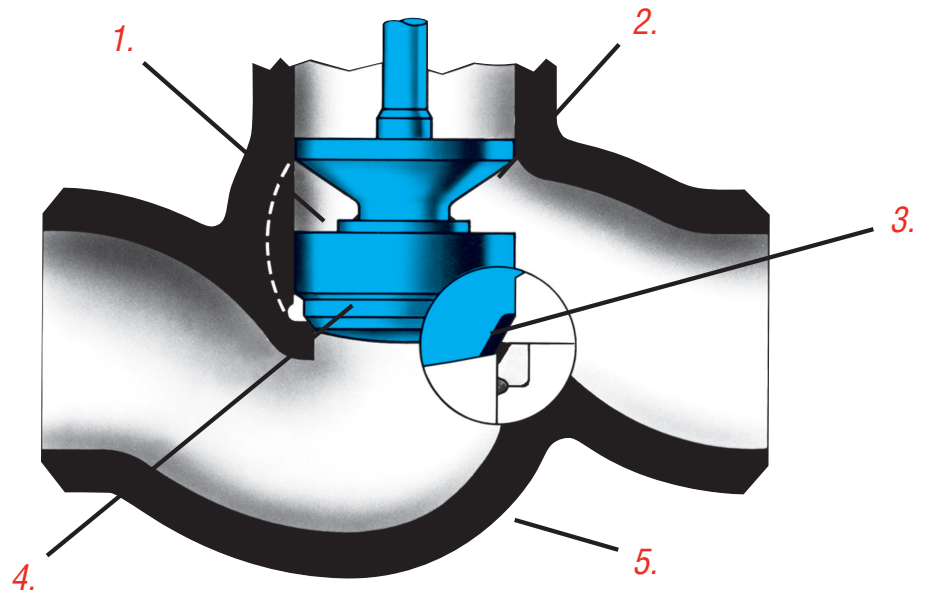

1. **Full body guides** ensure correct seat alignment.
2. **Plug skirt** prevents plug cocking even under turbulent flow conditions.
3. **Differential mating angles** between plug and seat ring ensure tight seal with low seating force.
4. **Swivel plug** ensures proper seat alignment and tight seal.
5. **Cast bodies** permit the internal flow passage to be designed with large radius curves. This provides smooth transitions and reduces damaging turbulence, which is unavoidable in bodies of forged and fabricated designs.

### Four Body Types

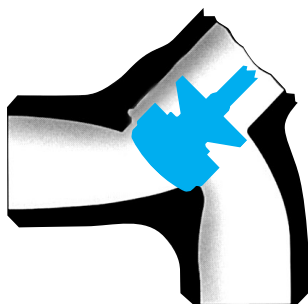

*Y Angle Globe*

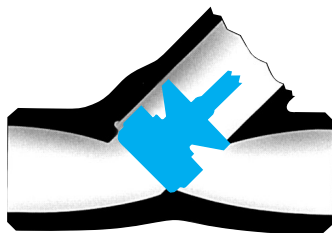

*Y Globe*

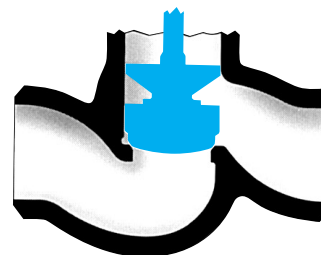

*Horizontal Globe*

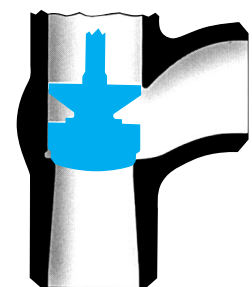

*Angle Globe*



Standard Plug

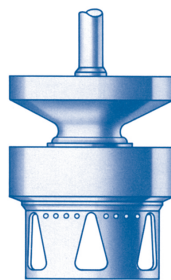

Cage Plug



Parabolic Plug

## Custom-Designed Plugs

Custom-designed plugs can be furnished to provide various flow characteristics through globe valves. The plug profile is designed for the desired flow characteristics of the specific service conditions.

FlowsERVE Flow Control manufactures four types of Anchor/Darling globe valve configurations, enabling customers to select the best globe valve for their specific throttling requirements. Each configuration is designed to minimize destructive turbulence.

State-of-the-art technology, backed up by almost a century of engineering, goes into each valve. Bodies are designed with large radius curves to ensure smooth transitions and eliminate abrupt changes in fluid direction. Damaging turbulence is reduced by custom-designed plugs that provide the desired flow characteristics. All four configurations are available in 2½" to 36" diameters, in pressure ratings from 150 to 4,500 pounds. Base material can be

carbon steel, stainless steel or one of many special alloys.

We can supply various combinations of seating and stem materials for specific customer requirements. Valves rated at less than pressure class 600 are equipped with bolted-bonnet type closures; those with ratings of pressure class 600 or higher can be supplied with either bolted or pressure seal-type bonnets.

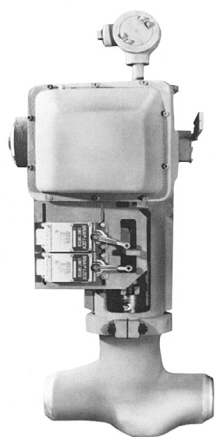

4" 600# Globe Valve



18" 300# Angle Globe

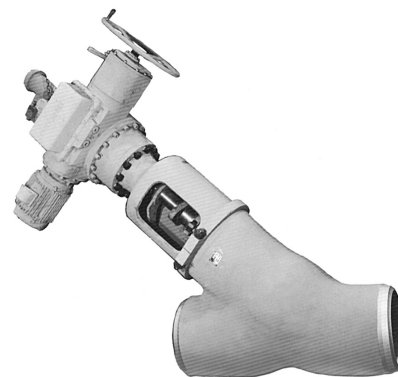

24" 900# Y-Globe

## Power-Actuated Globe Valves

FlowsERVE globe valves are easily adapted to power actuation. Electric motor, pneumatic and hydraulic units are commonly supplied, but custom designed systems can be furnished for your specific application. A complete complement of accessories is available to ensure that the equipment meets operating requirements. Double packing, limit switches, position indicators, air wrench adaptors, drains and bypasses are typical examples of accessories that can be supplied.



## Parts Specification List for Anchor/Darling Globe Valves

This is not a complete list. Construction and materials will vary between sizes and pressure classes and may be changed without notice. For a complete, accurate and itemized description of a particular valve, contact your Flowserve valves sales representative.

Description <sup>(1)</sup>	ASME/ARTM	ASME/ARTM
<b>Body/Bonnet*</b>	SA-216 Grade WCB	SA-351 Grade CF8M
<b>Disc</b>	SA-105 —	SA-182 Grade F316
<b>Disc Skirt</b>	A-105	A-182 Grade F316
<b>Stem</b>	A-582 Grade 416T	A-564 Grade 630-1075
<b>Yoke Bushing</b>	B-21 C464-H02	B-21 C464-H02
<b>Pressure Seal Gasket</b>	Composite Pressure Seal Gasket.	
<b>Bonnet Retainer Studs</b>	A-193 Grade B7	A-193 Grade B7
<b>Bonnet Retainer Nuts</b>	A-194 Grade 2H	A-194 Grade 2H
<b>Gland</b>	A-582 Grade 416T	A-479 Grade 304
<b>Eye Bolt</b>	A-193 Grade B7	A-193 Grade B7
<b>Eye Bolt Nuts</b>	A-194 Grade 2H	A-194 Grade 2H
<b>Eye Bolt Pins</b>	A-193 Grade 87	A-479 Grade 304
<b>Stem Clamp Key</b>	A-108 Grade 1018	A-108 Grade 1018
<b>Yoke</b>	A-216 Grade WCB	A-216 Grade WCB
<b>Yoke Lock Ring</b>	A-517 Grade 70	A-517 Grade 70
<b>Yoke Lock Ring Studs</b>	A-193 Grade B7	A-193 Grade B7
<b>Yoke Lock Ring Nuts</b>	A-194 Grade 2H	A-194 Grade 2H
<b>Handwheel</b>	A-53 Class SB	A-53 Grade SB
<b>Stem Retainer</b>	A-582 Grade 416T	A-564 Grade 630-1075

\* Other material grades available on application.

## Stop Valves, Class 150

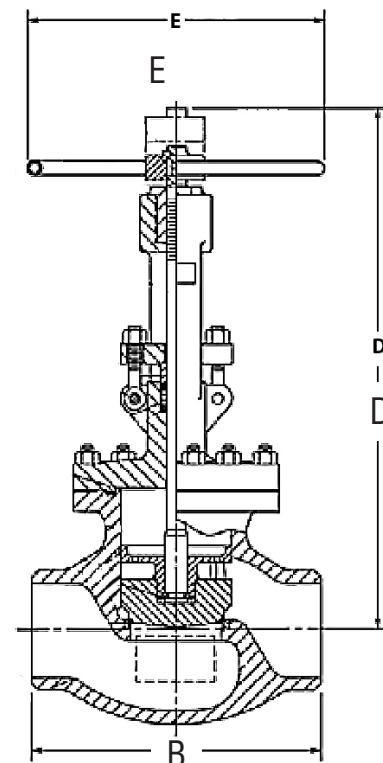

### Standard Features

- Carbon, stainless or special alloys
- Bolted bonnet
- Four body configurations
  - Tee
  - Angle
  - Y Globe
  - Y Angle
- Available Stellite seat, disc and backseat
- Body-guided disc
- Various combinations of seat and stem materials
- Swivel-style disc
- Differential mating angles between seat and disc

### Pressure Class 150 (PN 25)

Fig. No.	Type	Ends	NPS (DN)
BGB21U	Globe	Butt Weld	2½ (65) thru 24 (600)
BAG41U	Angle Globe	Butt Weld	2½ (65) thru 24 (600)
BYG31U	Y Globe	Butt Weld	2½ (65) thru 24 (600)
BYA80U	Y Angle	Butt Weld	2½ (65) thru 24 (600)
BGB21C	Globe	Flanged	2½ (65) thru 24 (600)
BAG41C	Angle Globe	Flanged	2½ (65) thru 24 (600)
BYG31C	Y Globe	Flanged	2½ (65) thru 24 (600)
BYA80C	Y Angle	Flanged	2½ (65) thru 24 (600)

### Dimensions – Globe

Black numerals are in inches and pounds  
Colored numerals are in millimeters and kilograms

Figure No. BGB21U, BGB31C Others Available upon request	NPS	2½	3	4	6	8	10	12	14	16	18	20	24
	DN	65	80	100	150	200	250	300	350	400	450	500	600
B		8.5	9.5	11.5	16.0	19.5	24.5	31.0	38	36.0	50.0	50.0	56.0
		216	241	292	406	495	622	787	965	914	1,270	1,270	1,422
D		17.0	21.0	22.0	38.0	43.0	45.0	50.0	54.0	61.0	69.0	79.0	94
		432	533	559	965	1,092	1,143	1,270	1,372	1,549	1,753	2,007	2,388
E		10.0	10.0	16	12.0	18.0	18.0	24.0	24.0	30.0	30.0	30.0	36.0
		254	254	407	305	457	457	610	610	762	762	762	914
Weight Approx (lbs.)		80	90	150	300	530	625	915	1300	1955	2625	3650	5100
		36.3	50.3	68	136.1	240.4	283.5	415	589.7	886.8	1,191	1,655.6	2,313.4
Cv		73.4	100	173	390	674	1060	1638	2139	2497	3790	4396	6150

Refer to page 102 for materials of construction.

Refer to pages 203 through 238 for the applicable pressure ratings.

## Stop Valves, Class 300

### Standard Features

- Carbon, stainless or special alloys
- Bolted bonnet
- Four body configurations
  - Tee
  - Angle
  - Y Globe
  - Y Angle
- Available Stellite seat, disc and backseat
- Body-guided disc
- Various combinations of seat and stem materials
- Swivel-style disc
- Differential mating angles between seat and disc

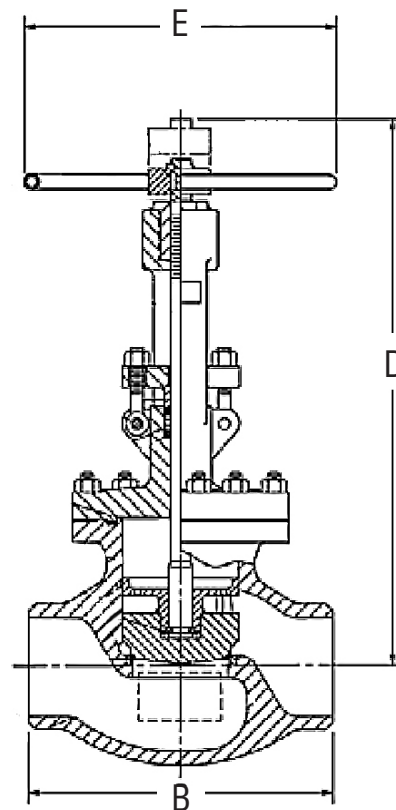

### Pressure Class 300 (PN 50)

Fig. No.	Type	Ends	NPS (DN)
CGB21U	Globe	Butt Weld	2½ (65) thru 24 (600)
CGB21C	Globe	Flanged	2½ (65) thru 24 (600)
CAG41U	Angle Globe	Butt Weld	2½ (65) thru 24 (600)
CAG41C	Angle Globe	Flanged	2½ (65) thru 24 (600)
CYG31U	Y Globe	Butt Weld	2½ (65) thru 24 (600)
CYG31C	Y Globe	Flanged	2½ (65) thru 24 (600)
CYA80U	Y Angle	Butt Weld	2½ (65) thru 24 (600)
CYA80C	Y Angle	Flanged	2½ (65) thru 24 (600)

### Dimensions – Globe

Black numerals are in inches and pounds  
Colored numerals are in millimeters and kilograms

Figure No. CGB21U/CGB21C Others Available upon request	NPS	2½	3	4	6	8	10	12	14	16	18	20	24
	DN	65	80	100	150	200	250	300	350	400	450	500	600
B		11.5	12.5	14	17.5	22	24.5	31	38	47	50	54	—
		292	318	356	495	559	622	787	965	1,194	1,270	1,372	—
D		17	21	24	42	44	49	51	59	61	75	85	98
		432	533	610	1,067	1,118	1,245	1,295	1,499	1,549	1,905	2,159	2,489
E		10	10	16	12	12	18	18	24	24	30	30	36
		254	254	406	305	305	457	457	610	610	762	762	914
Weight Approx (lbs.)		70	115	235	505	580	900	1,405	1,925	2,475	3,270	3,920	5,400
		31.8	52.2	106.6	229.1	263.1	408.2	637.3	873.2	1,122.7	1,483.3	1,778.1	2,449.4
Cv		89.6	119	196	472	730	1,060	1,931	2,139	2,975	3,300	4,548	6,159

Refer to page 102 for materials of construction.

Refer to pages 203 through 238 for the applicable pressure ratings.



## Stop Valves, Class 600

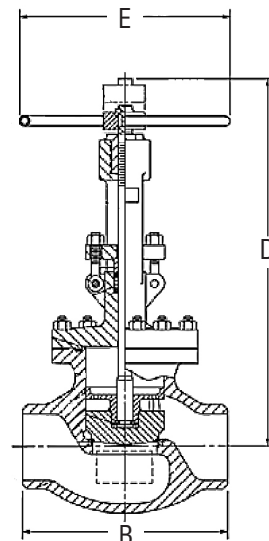

### Standard Features

- Carbon, stainless or special alloys
- Bolted or pressure seal bonnet
- Four body configurations
  - Tee
  - Angle
  - Y Globe
  - Y Angle
- Available Stellite seat, disc and backseat
- Body-guided disc
- Various combinations of seat and stem materials
- Swivel-style disc
- Differential mating angles between seat and disc

### Pressure Class 600 (PN 110)

Fig. No.	Type	Ends	NPS (DN)
EGB21U	Globe-Bolted Bonnet	Butt Weld	2½ (65) thru 24 (600)
EGB21C	Globe-Bolted Bonnet	Flanged	2½ (65) thru 24 (600)
EGB24U	Globe-Pressure Seal	Butt Weld	2½ (65) thru 24 (600)
EGB24C	Globe-Pressure Seal	Flanged	2½ (65) thru 24 (600)
EAG41U	Angle Globe-Bolted Bonnet	Butt Weld	2½ (65) thru 24 (600)
EAG41C	Angle Globe-Bolted Bonnet	Flanged	2½ (65) thru 24 (600)
EAG44U	Angle Globe-Pressure Seal	Butt Weld	2½ (65) thru 24 (600)
EAG44C	Angle Globe-Pressure Seal	Flanged	2½ (65) thru 24 (600)
EYG31U	Y Globe-Bolted Bonnet	Butt Weld	2½ (65) thru 24 (600)
EYG31C	Y Globe-Bolted Bonnet	Flanged	2½ (65) thru 24 (600)
EYG34U	Y Globe-Pressure Seal	Butt Weld	2½ (65) thru 24 (600)
EYG34C	Y Globe-Pressure Seal	Flanged	2½ (65) thru 24 (600)
EYA80U	Y Angle Bolted Bonnet	Butt Weld	2½ (65) thru 24 (600)
EYA80C	Y Angle Bolted Bonnet	Flanged	2½ (65) thru 24 (600)
EYA81U	Y Angle Pressure Seal	Butt Weld	2½ (65) thru 24 (600)
EYA81C	Y Angle Pressure Seal	Flanged	2½ (65) thru 24 (600)

### Dimensions – Globe

Black numerals are in inches and pounds  
Colored numerals are in millimeters and kilograms

Figure No. EGB21U/EGB21C, EGB24U/EGB24C others available upon request	NPS	2½	3	4	6	8	10	12	14	16	18	20	24
	DN	65	80	100	150	200	250	300	350	400	450	500	600
B		8.5	14	17	22	26	31	33	35	39	43	50	58
		216	356	432	559	660	787	838	889	991	1,092	1,270	1,473
D		23	24	26	43	47	51	60	66	72	81	87	96
		584	610	660	1,092	1,194	1,295	1,524	1,676	1,829	2,057	2,210	2,438
E		12	14	14	18	18	18	24	24	24	30	30	36
		305	356	356	457	457	457	610	610	610	762	762	914
Weight Approx (lbs.)		65	94	180	425	670	1,090	1,520	2,610	3,620	4,675	5,725	7,200
		29.5	42.6	81.6	192.8	303.9	434.4	689.5	1,184	1,642	2,120	2,597	3,266
Cv		70.9	129	221	479	798	1,195	1,669	1,960	2,529	3,267	4,125	5,853

Refer to page 102 for materials of construction.

Refer to pages 203 through 238 for the applicable pressure ratings.

## Stop Valves, Class 900

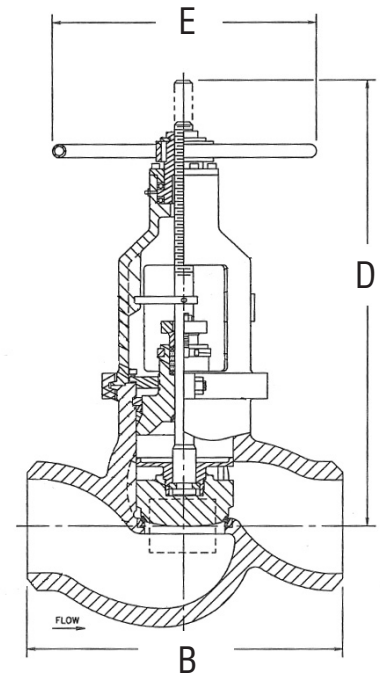

### Standard Features

- Carbon, stainless or special alloys
- Pressure seal bonnet
- Four body configurations
  - Tee
  - Angle
  - Y Globe
  - Y Angle
- Available Stellite seat, disc and backseat
- Body-guided disc
- Various combinations of seat and stem materials
- Swivel-style disc
- Differential mating angles between seat and disc

### Pressure Class 600 (PN 150)

Fig. No.	Type	Ends	NPS (DN)
FGB24U	Globe	Butt Weld	2½ (65) thru 24 (600)
FAG44U	Angle Globe	Butt Weld	2½ (65) thru 24 (600)
FYG34U	Y Globe	Butt Weld	2½ (65) thru 24 (600)
FYA81U	Y Angle	Butt Weld	2½ (65) thru 24 (600)

### Dimensions – Globe

Black numerals are in inches and pounds  
Colored numerals are in millimeters and kilograms

Figure No. FGB24U Others available upon request	NPS	2½	3	4	6	8	10	12	14	16	18	20	24
	DN	65	80	100	150	200	250	300	350	400	450	500	600
B		13	12	18	20	26	31	36	40.5	43	48	52	58
		330	305	457	508	660	787	914	1,029	1,092	1,219	1,321	1,473
D		24	28	33	45	49	56	62	68	77	83	92	98
		610	711	838	1,143	1,245	1,422	1,575	1,727	1,957	2,108	2,337	2,489
E		14 IMP	16 IMP	16 IMP	18	18	24	24	24	30	30	36	38
		356	381	381	457	457	610	610	610	762	762	914	914
Weight Approx (lbs.)		150	180	310	560	915	1,350	1,770	3,160	4,070	5,455	6,840	7,800
		68	81.6	140.6	254	415	612.4	802.9	1,433	1,846	2,474	3,102	3,538
Cv		83.3	107	217	421	745	1,133	1,644	2,021	2,515	3,298	4,002	5,492

Refer to page 102 for materials of construction.

Refer to pages 203 through 238 for the applicable pressure ratings.

## Stop Valves, Class 1500

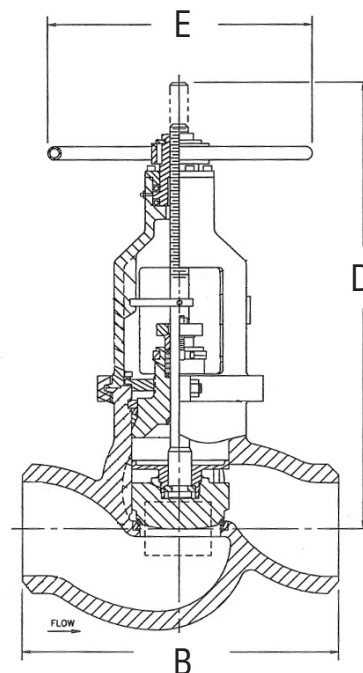

### Standard Features

- Carbon, stainless or special alloys
- Pressure seal bonnet
- Four body configurations
  - Tee
  - Angle
  - Y Globe
  - Y Angle
- Available Stellite seat, disc and backseat
- Body-guided disc
- Various combinations of seat and stem materials
- Swivel style disc
- Differential mating angles between seat and disc

### Pressure Class 1500 (PN 260)

Fig. No.	Type	Ends	NPS (DN)
GGB24U	Globe	Butt Weld	2½ (65) thru 24 (600)
GAG44U	Angle Globe	Butt Weld	2½ (65) thru 24 (600)
GYG34U	Y Globe	Butt Weld	2½ (65) thru 24 (600)
GYA81U	Y Angle	Butt Weld	2½ (65) thru 24 (600)

### Dimensions – Globe

Black numerals are in inches and pounds  
Colored numerals are in millimeters and kilograms

Figure No. GGB24U, GAG44U, GYG34U, GYA81U Others available upon request	NPS	2½	3	4	6	8	10	12	14	16	18	20	24
	DN	65	80	100	150	200	250	300	350	400	450	500	600
B		13	15	18	24	29	34	38	40	45	51	58	68
		330	381	457	610	737	864	965	1,016	1,143	1,295	1,473	1,727
D		24	25	28	49	53	60	68	72	81	87	98	100
		610	635	711	1,245	1,346	1,524	1,651	1,829	2,057	2,210	2,438	2,540
E		14 IMP	14 IMP	16 IMP	18	18	24	24	24	30	30	36	36
		356	356	406	457	457	610	610	610	762	762	1,296	1,296
Weight Approx (lbs.)		150	280	355	735	1,370	2,480	2,590	3,700	4,810	5,920	7,030	8,140
		68.0	127.0	161.0	333.4	621.4	1,125	1,175	1,678	2,182	2,685	3,189	3,692
Cv		83.3	119	201	435	733	1,102	1,552	1,813	2,345	3,097	3,929	5,567

Refer to page 102 for materials of construction.

Refer to pages 203 through 238 for the applicable pressure ratings.

Page intentionally left blank

## Edward Check Valves

## Piston Check Valves, Class 600

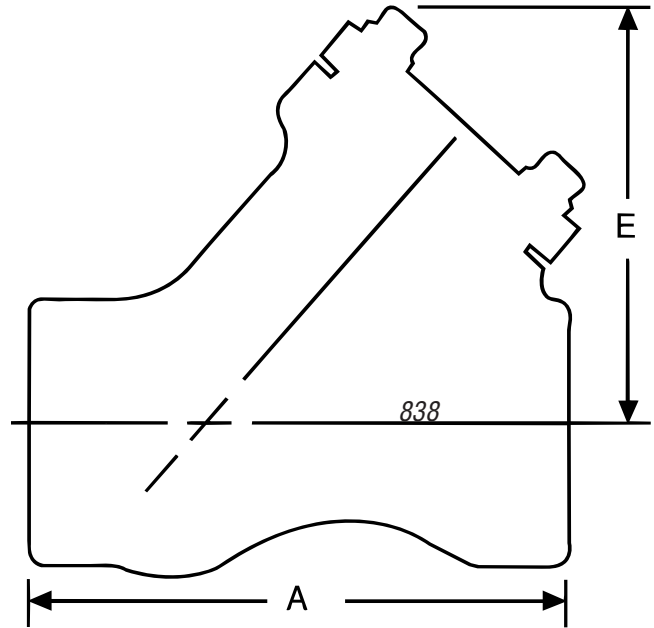
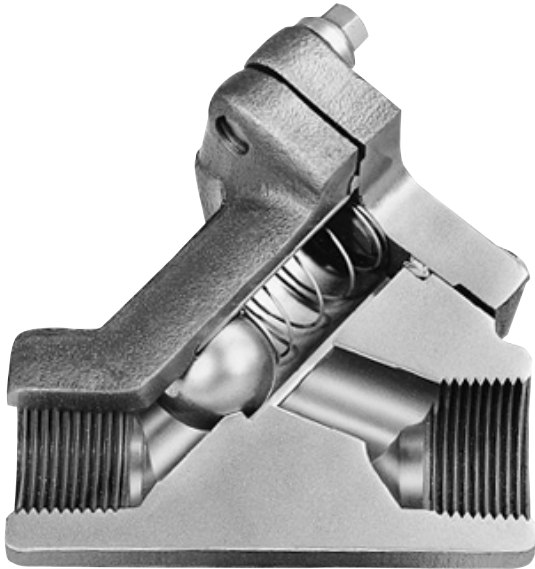

### Standard Features

- Bodies and covers are of forged steel (A105)
- Bolted cover
- Y Pattern
- Body-guided hardened stainless steel disc
- Integral Stellite seat
- Asbestos-free spiral-wound cover gasket
- Stainless steel spring (optional without springs)

### Pressure Class 600 (PN 110)

FIG. NO.	TYPE	ENDS	NPS (DN)
838	Y Pattern	Threaded	¼ (8) thru 2 (50)
838Y	Y Pattern	Socket Weld	¼ (8) thru 2 (50)

### Dimensions – Globe

Black numerals are in inches and pounds  
Colored numerals are in millimeters and kilograms

Figure No. 838/838Y	NPS	¼	3/8	½	¾	1	1¼	1½	2
	DN	8	10	15	20	25	32	40	50
A - End to End		3	3	3	3.6	4.3	5.8	5.8	6.5
		76	76	76	91	109	147	147	165
E - Center to Top		2.8	2.8	2.8	3.3	3.8	4.6	4.6	5.1
		71	71	71	84	97	117	117	130
Weight		2	2	2	3.5	5	11	10	14
		0.9	0.9	0.9	1.6	2.3	5	4.5	6.3

Refer to page 59 for materials of construction.  
Refer to pages 203 through 238 for the applicable pressure ratings.

## Univalve® Piston Check Valves, Class 1500

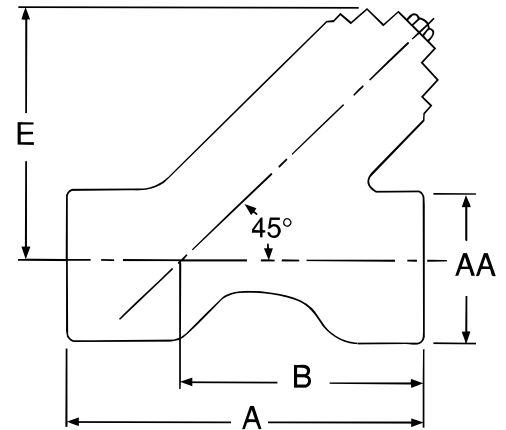
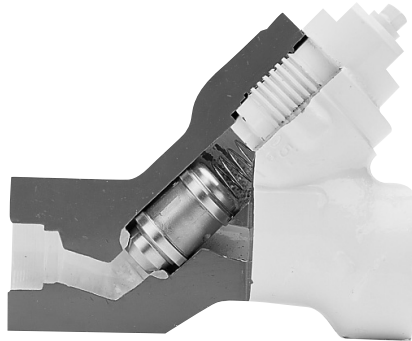

36174

### Standard Features

- Available body materials
  - SA105 carbon steel
  - F22 alloy steel
  - F316 stainless steel
  - Other material on application
- Unwelded (graphitic seal) or welded cover
- Y Pattern
- Body-guided investment cast Stellite disc
- Integral Stellite seat
- Stainless steel spring (optional without springs)

### Pressure Class 1500 (PN 260)

Fig. No.		Type	Ends	NPS (DN)
Welded	Unweld.			
36174	36274	Y Pattern	Socket Weld	½ (15) thru 2-½ (65)
36178	36278	Y Pattern	Butt Weld	½ (15) thru 4 (100)

### Dimensions

Black numerals are in inches and pounds  
Colored numerals are in millimeters and kilograms

Figure No. 36174, 36178, 36274, 36278	NPS	½	¾	1	1-¼	1-½	2	2-½	3	4
	DN	15	20	25	32	40	50	65	80	100
A - End to End		6.0	6.0	6.0	6.7	6.7	8.2	10.7	10.7	12.8
		152	152	152	170	170	208	272	272	325
AA - End Hub Diameter		2.30	2.30	2.30	3.20	3.20	3.64	4.00	4.00	4.80
		58	58	58	81	81	92	102	102	122
B - Center to End		4.0	4.0	4.0	4.8	4.8	6.1	7.1	7.1	8.8
		102	102	102	122	122	155	180	180	224
E - Center to Top		3.9	3.9	3.9	5.0	5.0	5.8	7.2	7.2	7.8
		99	99	99	127	127	147	183	183	198
Weight		14	14	14	22	22	31	44	44	86
		6	6	6	10	10	14	20	20	39

Refer to page 63 for materials of construction.  
Refer to pages 203 through 238 for the applicable pressure ratings.

## Univalve® Piston Check Valves, Class 2500

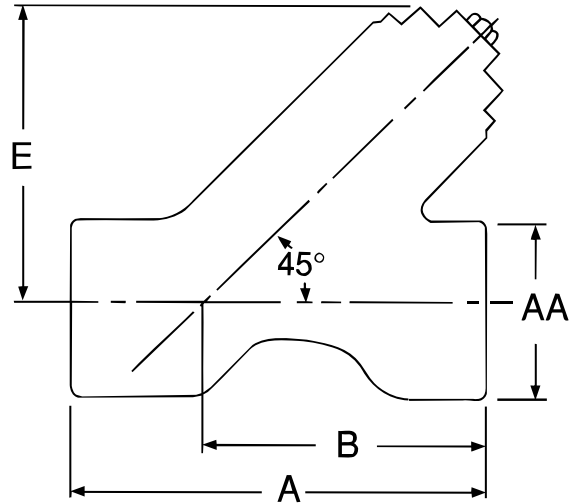
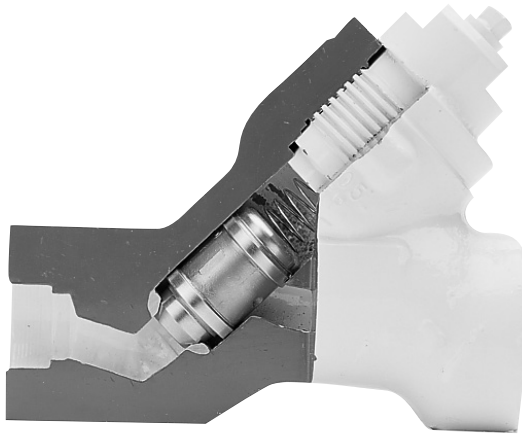

66174

### Standard Features

- Available body material
  - SA105 carbon steel
  - F22 alloy steel
  - F316 stainless steel
  - Other material on application
- Unwelded (graphitic seal) or welded cover
- Y Pattern
- Body-guided investment cast Stellite disc

### Pressure Class 2500 (PN 420)

Fig. No.		Type	Ends	NPS (DN)
Welded	Unweld.			
66174	66274	Y Pattern	Socket Weld	½ (15) thru 2½ (65)
66178	66278	Y Pattern	Butt Weld	½ (15) thru 4 (100)

- Integral Stellite seat
- Stainless steel spring  
(optional without springs)

### Dimensions – Globe

Black numerals are in inches and pounds  
Colored numerals are in millimeters and kilograms

Figure No. 66174, 66178, 66274, 66278	NPS	½	¾	1	1¼	1½	2	2½	3	4
	DN	15	20	25	32	40	50	65	80	100
A - End to End		6.0	6.0	6.0	6.7	6.7	10.7	12.8	12.8	12.8
		152	152	152	170	170	272	325	325	325
AA - End Hub Diameter		2.30	2.30	2.30	3.20	3.20	4.00	4.80	4.80	4.80
		58	58	58	81	81	102	122	122	122
B - Center to End		4.0	4.0	4.0	4.8	4.8	7.1	8.8	8.8	8.8
		102	102	102	122	122	180	224	224	224
E - Center to Top (Open)		3.9	3.9	3.9	5.0	5.0	7.0	7.8	7.8	7.8
		99	99	99	127	127	178	198	198	198
Weight		14	14	14	22	22	52	86	86	86
		6	6	6	10	10	24	39	39	39

Refer to page 63 for materials of construction.  
Refer to pages 203 through 238 for the applicable pressure ratings.



## Controlled Closure Check Valve

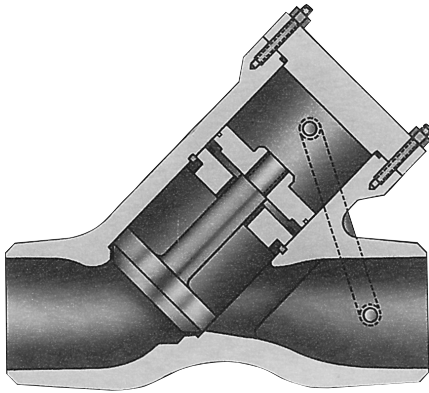

### Standard Features

- Minimizes waterhammer effects on postulated feedwater line break
- Computerized modeling verified by dynamic testing

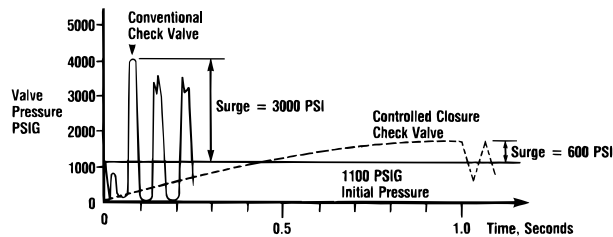
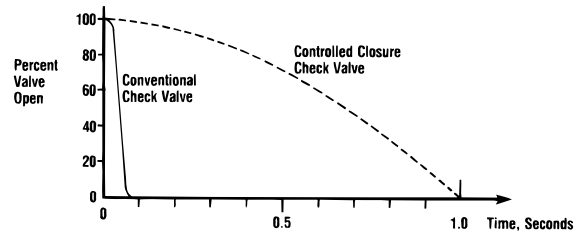

The Flowserve Edward Controlled Closure Check Valve was developed and qualified to serve a function that no other previous check valve could handle. If a feedwater line should rupture in a nuclear power plant, the reversed flow from the reactor or steam generator out of the containment boundary must be contained. Conventional check valves would close rapidly, but not fast enough to prevent high reverse flow velocity; closure of the conventional valve would produce severe pressure surges due to waterhammer—possibly severe enough to produce rupture of other piping or equipment.

The Controlled Closure Check Valve is much like a Flite-Flow piston lift check valve, but it has an integral “dashpot”—a plate with a close-clearance fit around the rod connecting the disc and piston. Flow paths sized for individual applications limit the flow out of the dashpot and consequently control the valve closing speed. See pg. 235-237 for a discussion of waterhammer and a comparison of the controlled closure check valve with other types.

As the final design section is very dependent on the specific application, consult with your Flowserve sales representative for more design details for this valve configuration.

## Features and Description of Flowserve Edward Check Valves

Over 75 years of valve field experience, coupled with ongoing research and development programs, have led to Flowserve Edward valves' reputation as a leader in supplying horizontal, angle, Flite-Flow and Elbow Down piston lift check valves.

These check valves incorporate time-proven design features such as equalizers for full lift at lower flows; body-guided disc-piston assemblies for seat alignment and stable operation; integral Stellite seating surfaces for long life and tight sealing; and streamlined flow shapes for low-pressure drop. Flowserve Edward valves maintain a reputation for the "Preferred" valve in critical high-pressure, high-temperature applications.

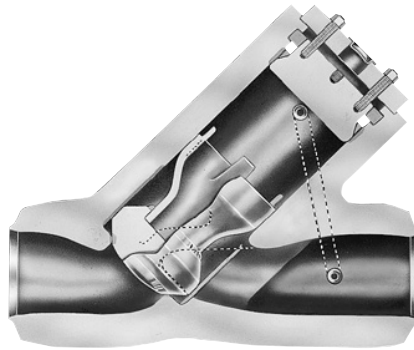

**Flite-Flow®**

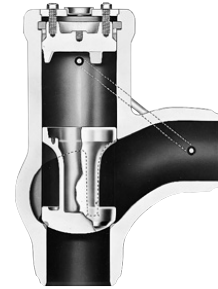

**Angle**

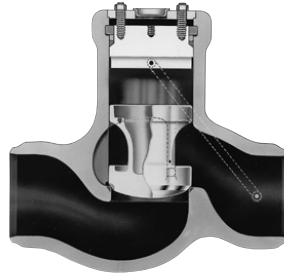

**Globe**

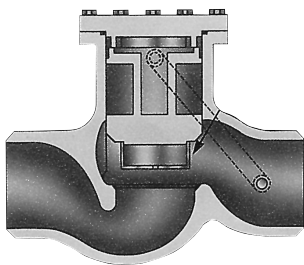

### **Flowserve - Edward Skirted Check Valves**

For check or stop-check applications with a broad range of flow conditions, a "skirted" disc, identified by adding the suffix "K" to the valve figure number, may provide the required minimum lift at low flow while providing acceptable pressure drop at maximum flow. Specifically, the illustrated disc with a Mini-Skirt provides good low-flow performance while reducing  $C_v$  by only 10%. See the Flowserve Edward Valves technical article EVAWP3019 for assistance on high-turndown applications.

## Features and Description of Flowserve Edward One-Piece Tilting-Disc Check Valves

The Edward tilting-disc check valve is designed to close as quickly as possible. It minimizes loud, damaging slamming and vibration noises caused when high-velocity reverse flow is allowed to build up before the completion of closing.

### Quick Closing

Quick closing is achieved through a combination of several design construction features. The disc is dome-shaped to avoid hesitation of disc motion or closing, common to conventional flat discs. For minimum pendulum period—an important factor in assuring quick closing—the disc pivot is located close to the center of gravity of the disc.

All disc surfaces are open to line fluid so that no dashpot action can delay closing. The disc pivots on pin supports having chrome-plated bearings for minimum friction. Totally enclosed torsion springs in the pivot pins help speed the closing action, although the disc is counterweighted sufficiently to close automatically without aid from the springs whether the valve is in a vertical or horizontal position. Since the springs are fully enclosed in the pins, they are not subject to possible erosive effects of line fluids and foreign matter cannot get in. There is no bolting in the flow stream.

### Adjustable Hinge Pins

Available factory installed or as a conversion kit, Edward valves' unique, adjustable hinge pin replaces the usual concentric hinge pins with double offset eccentric hinge pins, making core alignment a matter of simply dialing in the fit.

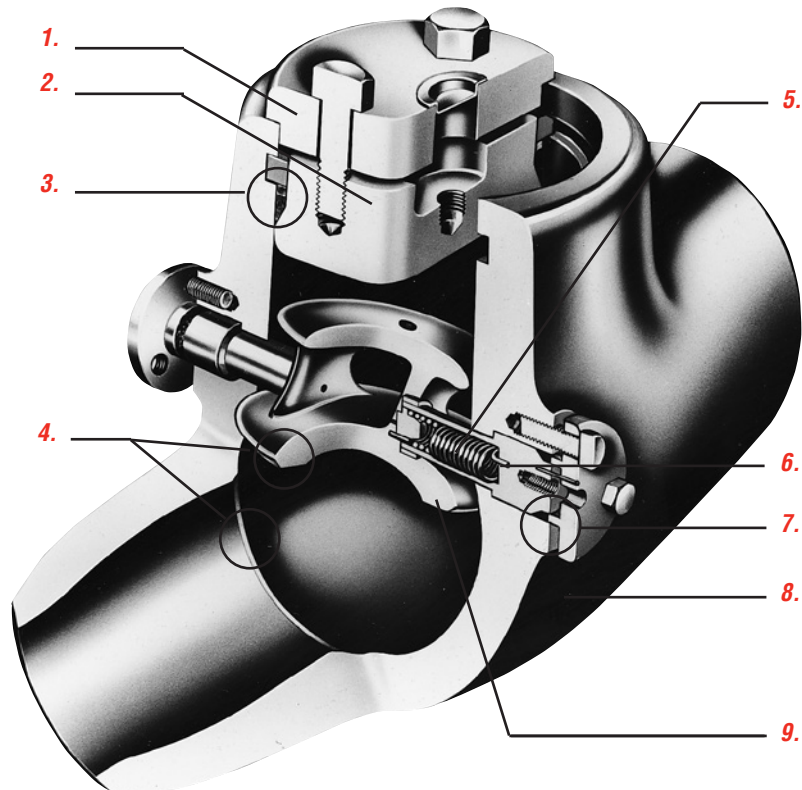

1. **Cover retainer** provides loading through the cover retainer and bolting to initiate a seal at the pressure seal gasket.
2. **Cover is precision machined** to retain pressure integrity and critical gasket seating surfaces.
3. **Composite pressure seal gasket** is a pre-loaded pressure energized flexible graphite composite for long, reliable service.
4. **Integral hardsurfaced seats**, both body and disc, provide positive shutoff and long seat life.
5. **Springs ensure quick closing** of the disc by providing a positive seating force to speed closing.
6. **Hinge pin** provides a disc pivot point close to its center of gravity for fast response to flow reversals, which minimizes water-hammer effects.
7. **Hinge pin gasket** is spiral wound, coated steel, or flexible graphite for long, reliable service.
8. **Body features** a straight-thru compact design for low-pressure drop.
9. **Disc assembly** is dome-shaped and counterweighted for fast response to flow reversals.

## Parts Specification List for Flowserve Edward One-Piece Tilting-Disc Check Valve

This is not a complete list. Construction and materials will vary between sizes and pressure classes and may be changed without notice. For a complete, accurate and itemized description of a particular valve, contact your Flowserve Edward valves sales representative.

Description <sup>(1)</sup>	ASME/ASTM No.	ASME/ASTM No.	ASME/ASTM No.	ASME/ASTM No.
<b>Body/Cover*</b>	SA-216 Grade WCB	SA-216 Grade WCC	SA-217 Grade WC9	SA-351 Grade CF8M
<b>Disc††</b>	SA-105 —	SA-105 —	SA-182 Grade F22	SA-182 Grade F316
<b>Pressure Seal Gasket*</b>	Composite Pressure Seal Gasket			
<b>Spacer Ring</b>	A-668 Grade 4140 MnPO <sub>4</sub> Plated	A-668 Grade 4140 MnPO <sub>4</sub> Plated	A-668 Grade 4140 MnPO <sub>4</sub> Plated	Grade 182 Grade F6 CL4
<b>Gasket Retainer</b>	SA-182 Grade F6 CL4	A-182 Grade F6 CL4	A-565 Grade 616 HT	A-638 Grade 660 T2
<b>Cover Retainer</b>	A-216 Grade WCB	A-216 Grade WCB	A-216 Grade WCB	A-216 Grade WCB
<b>Cover Retainer Capscrews or Studs</b>	A-193 Grade B7	A-193 Grade B7	A-193 Grade B7	A-193 Grade B7
<b>Cover Retainer Nuts</b>	A-194 Grade 2H	A-194 Grade 2H	A-194 Grade 2H	A-194 Grade 2H
<b>Hinge Pin Gasket Size 2½, 3, 4</b>	Spiral Wound Gasket (Asb. Free)	Spiral Wound Gasket (Asb. Free)	Spiral Wound Gasket (Asb. Free)	Spiral Wound Gasket (Asb. Free)
<b>Hinge Pin Gasket Size 6 &amp; Larger</b>	Graphite Gasket			
<b>Hinge Pin</b>	A-182 Grade F6aCL4	A-182 Grade F6aCL4	A-565 Grade 616 HT	A-638 Grade 660 Type 2
<b>Hinge Pin Bolts</b>	A-193 Grade B7	A-193 Grade B7	A-193 Grade B16	A-453 Grade 660B
<b>Hinge Pin Retainer</b>	A-105 —	A-105 —	A-182 Grade F22	A-182 Grade F316
<b>Hinge Pin Springs†</b>	A-313	A-313	A-313	A-313

<sup>(1)</sup>Other material grades available on application. <sup>(2)</sup>All ANSI Class 600 valves utilize an asbestos-free spiral wound bonnet gasket.

†Hinge Pin Torsion Springs required in size 6 and larger valves only. ††Sizes 2½, 3 and 4, Pressure Classes 900, 1500 and 2500 – disc material is A732-GR21

## Check Valves, Class 600

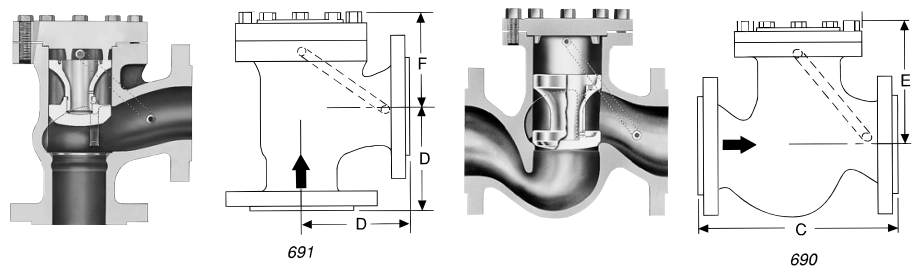

### Standard Features

- Bodies and covers are cast steel (WCB, WCC, WC9, CFBM)
- Bolted or pressure-seal cover
- Y Pattern, globe, angle, or tilting disc
- Integral Stellite seats
- Body-guided disc piston, globe, angle and Flite-Flow
- Long Terme<sup>®</sup> steel or pressure-seal gasket
- Equipped with equalizer, globe, angle and Flite-Flow

### Pressure Class 600 (PN 110)\*

Fig. No.		Type	Ends	Bonnet	NPS (DN)
STD CL	SPL CL				
670Y	770Y	Tilting Disc	Butt Weld	Bolted	6 (150) thru 20 (500)
690	—	Globe	Flanged	Bolted	2½ (65) thru 6 (150)
690Y	—	Globe	Butt Weld	Bolted	
691	—	Angle	Flanged	Bolted	
691Y	—	Angle	Butt Weld	Bolted	
***692	—	Flite-Flow	Flanged	*Pressure Seal	3 (80) thru 32 (800)
692Y	792Y	Flite-Flow	Butt Weld	*Pressure Seal	
694	—	Globe	Flanged	Pressure Seal	8 (200) thru 14 (350)
694Y	794Y	Globe	Butt Weld	Pressure Seal	
695	—	Angle	Flanged	Pressure Seal	
695Y	795Y	Angle	Butt Weld	Pressure Seal	

\* Size 3 and 4 - Bolted bonnet with asbestos-free spiral-wound gasket.

\* Size 3 and 4 Butt weld Flite-Flow valves are Class 700.

### Dimensions – Globe & Angle

Black numerals are in inches and pounds  
Colored numerals are in millimeters and kilograms

Figure No. 690/690Y, 691/691Y, 694/694Y, 695/695Y, 794Y, 795Y	NPS	2½	3	4	5	6	8	10	12	14
	DN	65	80	100	125	150	200	250	300	350
C - Face to Face, Globe (Flanged)•		13	14	17	20	22	26	31	33	35
		330	356	432	508	559	660	787	838	889
D - Center to Face, Angle (Flanged)•		6.5	7	8.5	10	11	13	15.5	16.5	17.5
		165	178	216	254	279	330	394	419	445
E - Center to Top, Globe		6.6	7.1	8.9	11.4	13.1	17.3	20.2	23.2	25.1
		168	180	226	290	333	439	513	589	638
F - Center to Top, Angle		4.8	5.0	6.4	8.0	8.9	11.9	13.4	15.5	16.6
		122	127	163	203	226	302	340	394	422
H - Clearance for Equalizer		8.7	8.5	10	9.6	11	11.8	13	13.7	15.7
		221	216	254	244	279	300	330	348	399
Weight, Globe (Flanged)		80	110	210	360	460	815	1290	1870	2320
		36	50	95	163	209	370	585	848	1052
Weight, Globe (Welding)		60	80	140	250	325	620	1040	1550	1930
		27	36	64	113	147	281	472	703	875
Weight, Angle (Flanged)		72	95	184	290	380	590	990	1490	1830
		33	43	84	132	172	268	449	676	830
Weight, Angle (Welding)		50	70	124	180	250	400	710	1170	1440
		23	32	56	82	113	181	322	531	653

• Center-to-end or end-to-end dimensions for welding end valves same as center-to-contact-face or contact-face-to-contact-face dimensions for flanged end valves.

# Long Terme steel is a product coated by immersion in molten Terme metal. Terme metal is an alloy of lead and a small amount (about 3%) of tin.

\*\*\* Flanged valves available in sizes 3 through 16.

Refer to page 116 for materials of construction.

Refer to pages 203 through 238 for the applicable pressure ratings.

# Check Valves, Class 600

## Standard Features

- Bodies and covers are cast steel (WCB, WCC, WC9, CF8M)
- Bolted or pressure-seal cover
- Y Pattern, globe, angle or tilting disc
- Integral Stellite seats
- Body-guided disc piston, globe, angle and Flite-Flow
- Gasket: Sizes 3 and 4 asbestos-free, spiral wound; all others: composite pressure seal
- Equipped with equalizer, globe, angle and Flite-Flow

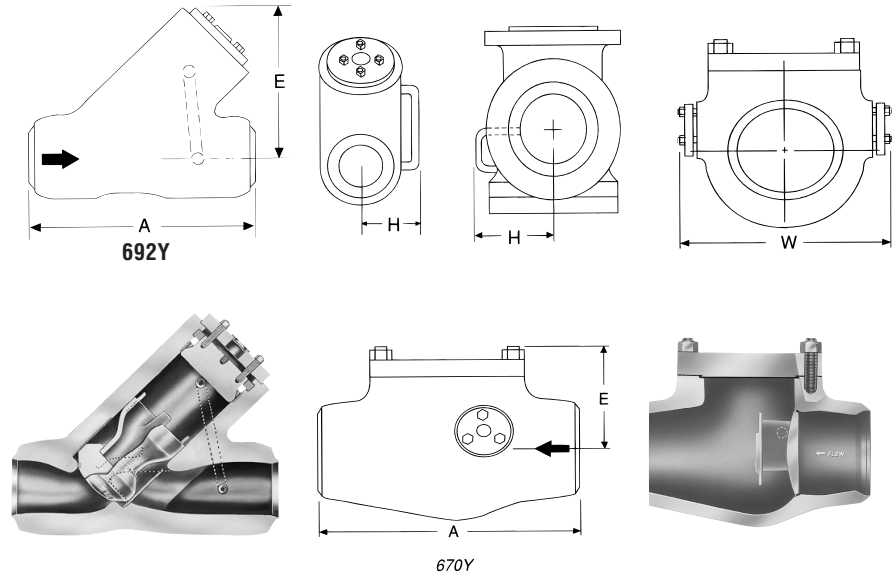

## Dimensions – Flite-Flow

Black numerals are in inches and pounds  
Colored numerals are in millimeters and kilograms

Figure No. 692Y/792Y ***692	NPS	3	4	6	8	10	12	14	16	20	24	26	28	32
	DN	80	100	150	200	250	300	250	400	500	600	650	700	800
A - End to End (Welding)		13	15.5	20	26	31	38	38	41	60	66	70	81.5	90
		330	394	508	660	787	965	965	1041	1524	1676	1778	2070	2286
A <sub>2</sub> - Face to Face (Flanged)		16.75	21.5	29	33	39	45	45	52	*	*	*	*	*
		425	540	737	838	991	1143	1143	1321	*	*	*	-	-
E - Center to Top		7	11	15.75	17.75	21.25	25.25	25.25	31.5	36.0	*	*	*	*
		178	279	400	451	540	641	641	800	914				
H - Equalizer Clearance		7	9	10	12	13	14	14	22	24	*	*	*	*
		178	229	254	305	330	356	356	559	610	*	*	*	*
Weight (Welding)		80	125	375	575	1000	1450	1450	3300	*	*	*	*	*
		35	55	170	261	454	658	658	1497					
Weight (Flanged)		120	200	520	750	1250	1900	2150	4300	*	*	-	-	-
		54	90	236	340	567	862	975	1950					

Notes: Size 3 and 4 Butt-weld Class 600 Flite-Flow valves are Class 700.

\* E, H and other dimensions and information supplied upon request.

\*\*\* Flanged valves available in sizes 3 through 16.

## Dimensions – Tilting Disc

Figure No. 670Y/770Y	NPS	6	8	10	12	14	16	18	20
	DN	150	200	250	300	350	400	450	500
A - End to End (Welding)		19.5	22	28.5	34.5	34.5	43.25	48.25	53.5
		495	559	724	876	876	1099	1226	1359
E - Center to Top		9.5	10.5	13.5	15.5	15.5	20.5	22.5	23.75
		241	267	343	394	394	521	572	603
W - Width		15.25	17.5	21	25	25	32.25	34	38.5
		387	445	533	635	635	819	864	978
Weight (Welding)		300	500	950	1450	1550	2550	3550	5650
		136	225	428	653	698	1148	1598	2543

Refer to page 116 for materials of construction.

Refer to pages 203 through 238 for the applicable pressure ratings.

## Check Valves, Class 900

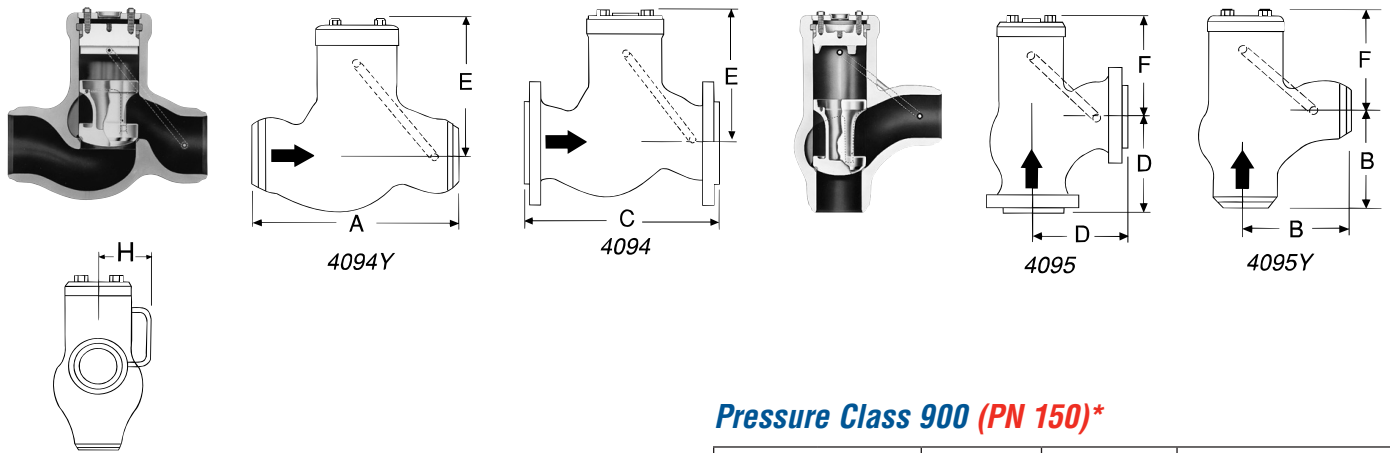

### Standard Features

- Bodies and covers are cast steel (WCB, WCC, WC9, CF8M)
- Pressure-seal cover
- Globe, angle and tilting-disc design
- Integral Stellite seats
- Body-guided disc piston (Globe and Angle)
- Equipped with equalizer (Globe and Angle)

### Pressure Class 900 (PN 150)\*

Fig. No.		Type	Ends	NPS (DN)
STD CL	SPL CL			
970Y	4370Y	Tilting-Disc	Butt Weld	2½ (65) thru 24 (600)
4094	—	Globe	Flanged	3 (80) thru 14 (350)
4094Y	4394Y	Globe	Butt Weld	
4095	—	Angle	Flanged	3 (80) thru 24 (600)
4095Y	4395Y	Angle	Butt Weld	
4092	—	Flite-Flow	Flanged	3 (80) thru 16 (400)
4092Y	4392Y	Flite-Flow	Butt Weld*	

\*Size 3 and 4 Buttweld Flite-Flow Valves are Class 1100

### Dimensions – Globe & Angle

Black numerals are in inches and pounds  
Colored numerals are in millimeters and kilograms

Figure No. 4094/4094Y, 4095/4095Y, 4394Y, 4395Y	NPS	3	4	5	6	8	10	12	14
	DN	80	100	125	150	200	250	300	350
A - End to End (Welding)		15	18	22	24	29	33	38	40.5
		381	457	559	610	737	838	965	1029
B - Center to End (Welding)		7.5	9	11	12	14.5	16.5	19	20.25
		190	229	279	305	368	419	483	514
C - Face to Face (Flanged)		15	18	22	24	29	33	38	40.5
		381	457	559	610	737	838	965	1029
D - Center to Face (Flanged)		7.5	9	11	12	14.5	16.5	19	20.25
		190	229	279	305	368	419	483	514
E - Center to Top, Globe		11	12	13.75	15.63	18.5	22.25	26.25	28.75
		279	305	349	397	470	565	667	730
F - Center to Top, Angle		9.25	10.25	11.25	12.5	16	16.75	21.5	21.5
		235	260	286	318	406	425	546	546
H - Clearance for Equalizer		7.5	7.63	9.75	10.75	12.5	12.88	14.75	17.38
		190	194	248	273	318	327	275	441
Weight, Globe (Flanged)		140	246	426	550	1188	1310	2710	3820
		64	112	193	249	539	594	1229	1733
Weight, Globe (Welding)		108	160	272	400	840	1090	2110	3070
		49	73	123	181	381	494	957	1393
Weight, Angle (Flanged)		134	217	356	485	898	1080	2165	2345
		61	98	161	220	407	490	982	1064
Weight, Angle (Welding)		115	131	202	290	510	860	1565	1860
		52	59	92	132	231	390	710	844

Refer to page 116 for materials of construction.

Refer to pages 203 through 238 for the applicable pressure ratings.

## Check Valves, Class 900

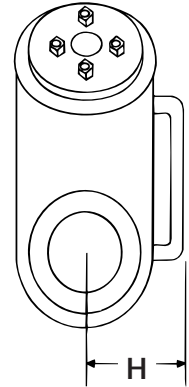
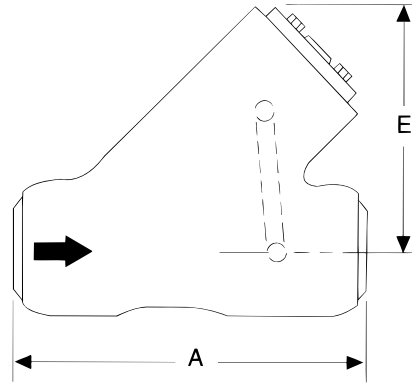
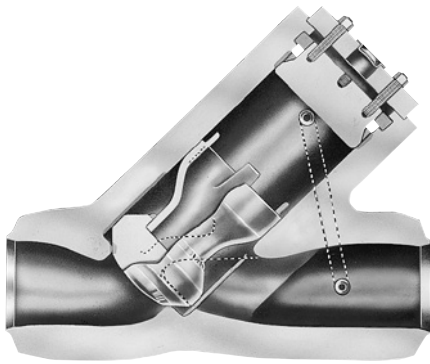

4092Y

### Standard Features

- Bodies and covers are cast steel (WCB, WCC, WC9, CF8M)
- Pressure-seal cover
- Y Pattern
- Integral Stellite seats
- Body-guided disc piston
- Equipped with equalizer

### Dimensions – Flite-Flow

Black numerals are in inches and pounds  
Colored numerals are in millimeters and kilograms

Figure No. 4092/4092Y, 4392Y	NPS	3	4	6	8	10	12	14	16
	DN	80	100	150	200	250	300	350	400
A <sub>1</sub> - End to End (Welding)		17	18.5	20	26	31	38	38	44.5
		432	470	508	660	787	914	914	1092
A <sub>2</sub> - Face to Face (Flanged)		22.25	23.75	30	38	44	50	51	58
		565	603	762	965	1118	1270	1295	1473
E - Center to Top		10	11	13.5	17.25	20.25	24	24	30
		254	279	343	438	514	610	610	762
H - Equalizer Clearance		9	9.3	10	12.5	16	15	15	25.75
		229	236	254	318	406	381	381	654
Weight (Welding)		130	175	300	710	1300	2050	2050	3900
		59	79	136	322	590	930	930	1769
Weight (Flanged)		190	250	520	1100	1850	2800	3200	5300
		86	113	236	499	839	1270	1452	2404

**Note:** Size 3 and 4 Butt-weld Class 900 Flite-Flow valves are Class 1100.

\* Impactor handwheel is standard on all valves.

Refer to page 116 for materials of construction.

Refer to pages 203 through 238 for the applicable pressure ratings.



## Check Valves Class 900

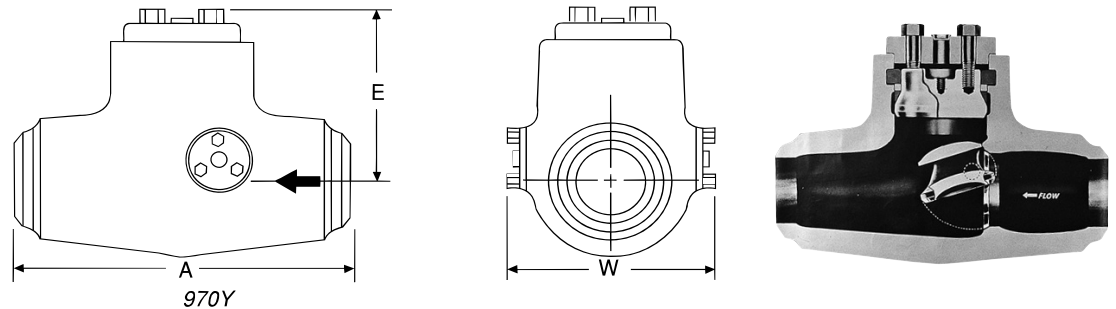

### Dimensions – Angle

Black numerals are in inches and pounds  
Colored numerals are in millimeters and kilograms

Figure No. 4095/4095Y, 4395Y	NPS	16	18	20	24
	DN	400	450	500	600
B - Center to End, (Welding)		26	29	32.5	39
		660	737	825	991
F - Center to Top, Angle (Open)		29	32	32	36
		737	813	813	914
G - Handwheel Diameter		20	21	21.5	30
		508	533	546	762
Weight, Angle (Welding)		2675	3710	4930	8190
		1213	1682	2636	3714

### Dimensions – Tilting-Disc

Figure No. 970Y, 4370Y	NPS	2½*	3*	4*	6	8	10
	DN	65	80	100	150	200	250
A - End to End (Welding)		12	12	12	22	28	34
		305	305	305	559	711	864
E - Center to Top		7.25	7.25	7.25	9.25	11	13
		184	184	184	235	279	330
W - Width		10.5	10.5	10.5	16.5	16	20.5
		267	267	267	419	406	521
Weight (Welding)		95	95	120	535	600	1010
		43	43	54	243	272	458

\* Spiral-wound hinge pin gaskets; hinge pin torsion spring not required.

Figure No. 970Y, 4370Y	NPS	12	14	16	18	20	24
	DN	300	350	400	450	500	600
A - End to End (Welding)		42	40.5	47	53	51.5	78
		1067	1029	1194	1346	1308	1981
E - Center to Top		15.75	15.75	18.75	18.75	23	36
		400	400	476	476	584	914
W - Width		26.5	26.5	29	29	37.5	55
		673	673	737	737	953	1397
Weight (Welding)		2090	2090	3260	3300	4510	10,200
		948	948	1479	1497	2046	4627

Refer to page 116 for materials of construction.

Refer to pages 203 through 238 for the applicable pressure ratings.

## Check Valves, Class 1500

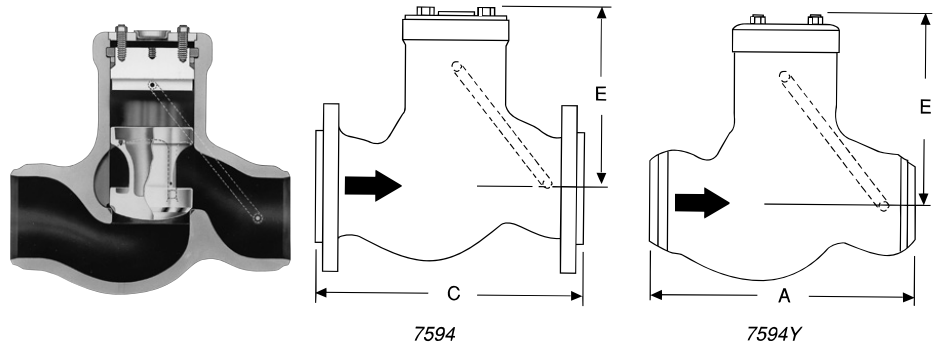

### Standard Features

- Bodies and covers are cast steel (WCB, WCC, WC9, CF8M)
- Pressure-seal cover OS & Y
- Globe or angle design
- Integral Stellite seats
- Body-guided disc piston
- Equipped with equalizer

### Pressure Class 1500 (PN 260)\*

Fig. No.		Type	Ends	NPS (DN)
STD CL	SPL CL			
7594	—	Globe	Flanged	2½ (65) thru 14 (350)
7594Y	2094Y	Globe	Butt Weld	
7595	—	Angle	Flanged	2½ (65) thru 24 (600)
7595Y	2095Y	Angle	Butt Weld	
7592Y	2092Y	Flite-Flow	Butt Weld*	3 (80) thru 24 (600)

\*Size 3 and 4 Butt-weld Flite-Flow Valves are Class 1800.

### Dimensions – Globe & Angle

Black numerals are in inches and pounds  
Colored numerals are in millimeters and kilograms

Figure No. 2094Y, 2095Y, 7594/7594Y, 7595/7595Y	NPS	2½	3	4	5	6	8	10
	DN	65	80	100	125	150	200	250
A - End to End (Welding)		13	15	18	22	24	29	33
		330	381	457	559	610	737	838
B - Center to End (Welding)		6.5	7.5	9	11	12	14.5	16.5
		165	190	229	279	305	368	419
C - Face to Face (Flanged)		16.5	18.5	21.5	26.5	27.75	32.75	39
		419	470	546	673	705	832	991
D - Center to Face (Flanged)		8.25	9.25	10.75	13.25	13.88	16.38	19.5
		210	235	273	337	353	416	495
E - Center to Top, Globe		9.25	11	12	13.75	15	18.75	20.75
		235	279	305	349	381	476	527
F - Center to Top, Angle		8.25	9.25	10.25	11.25	13	15.75	17.25
		210	235	260	286	330	400	438
H - Clearance for Equalizer		6.75	7.75	7.75	10	10.75	12.75	14
		171	197	197	254	273	324	356
Weight, Globe (Flanged)		125	195	320	534	684	1390	2360
		57	88	145	242	310	631	1070
Weight, Globe (Welding)		65	115	180	308	470	960	1530
		29	52	82	140	213	435	694
Weight, Angle (Flanged)		107	186	290	350	470	1070	1060
		49	84	132	159	213	485	481
Weight, Angle (Welding)		57	94	152	260	340	680	1230
		26	43	69	118	154	308	558

Refer to page 116 for materials of construction.

Refer to pages 203 through 238 for the applicable pressure ratings.

## Check Valves, Class 1500

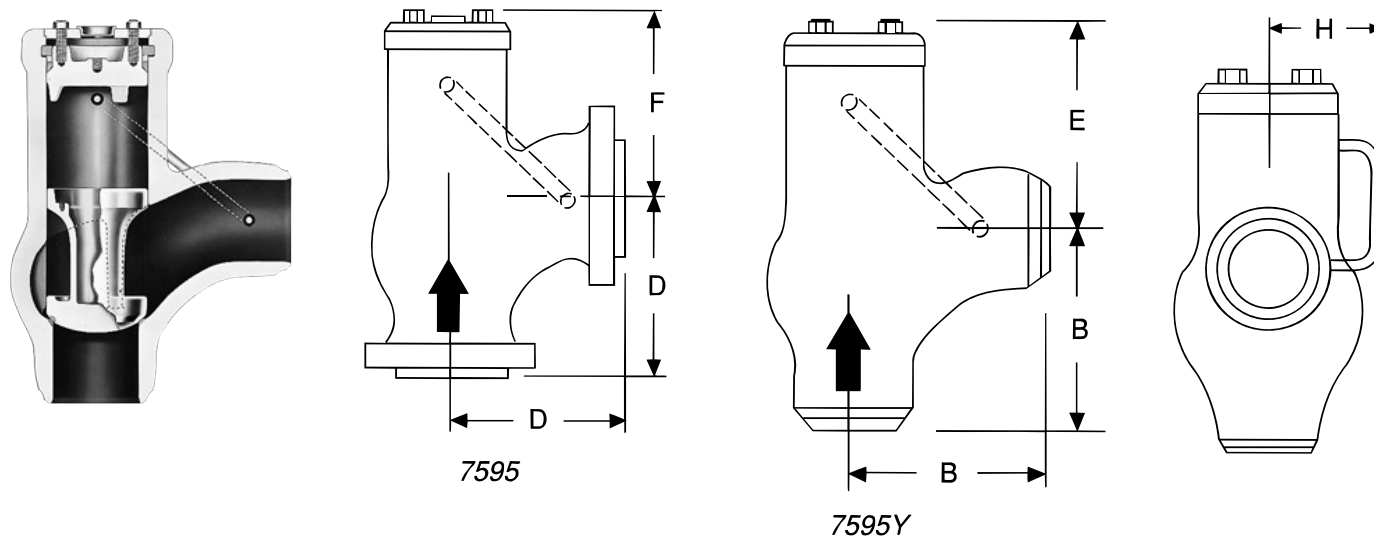

### Dimensions – Globe & Angle

Black numerals are in inches and pounds  
Colored numerals are in millimeters and kilograms

Figure No. 2094Y, 2095Y, 7594/7594Y, 7595/7595Y	NPS	12	14	16	18	20	24
	DN	300	350	400	450	500	600
A - End to End (Welding)		38	40.5	Valve Not Available			
		965	1029				
B - Center to End (Welding)		19	20.25	23.5	23.5	28.5	35.5
		483	514	597	597	724	902
C - Face to Face (Flanged)		44.5	49.5	Valve Not Available			
		1130	1257				
D - Center to Face (Flanged)		22.25	24.75	Available Upon Request			
		565	629				
E - Center to Top, Globe		24.25	30	Valve Not Available			
		616	762				
F - Center to Top, Angle		20.5	25	24.5	24.5	42	51
		521	635	622	622	1067	1295
H - Clearance for Equalizer		15	17.38	19.5	19.5	23	28.5
		381	441	495	495	584	724
Weight, Globe (Flanged)		3100	4400	Valve Not Available			
		1406	1995				
Weight, Globe (Welding)		2310	3300	Available Upon Request			
		1040	1497				
Weight, Angle (Flanged)		2320	3900	Valve Not Available			
		1044	1769				
Weight, Angle (Welding)		1530	2060	4700	4880	6820	11,600
		686	927	2131	2213	3093	5261

Refer to page 116 for materials of construction.  
Refer to pages 203 through 238 for the applicable pressure ratings.

## Check Valves, Class 1500

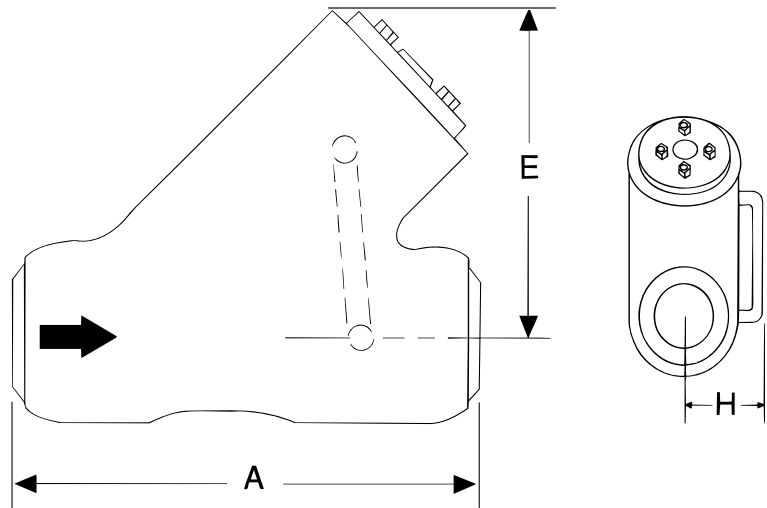
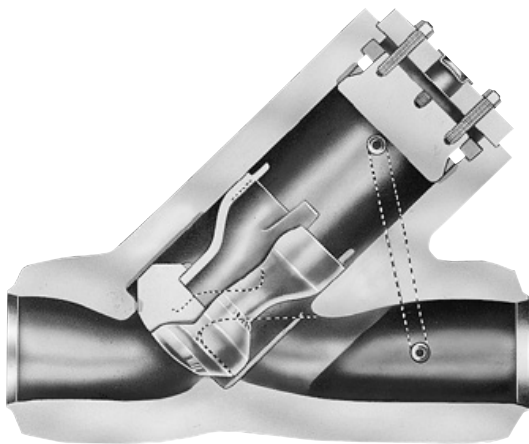

7592Y

### Standard Features

- Bodies and covers are cast steel (WCB, WCC, WC9, CF8M)
- Pressure-seal cover
- Y Pattern
- Integral Stellite seats
- Body-guided disc piston
- Equipped with equalizer

### Dimensions – Flite-Flow

Black numerals are in inches and pounds  
Colored numerals are in millimeters and kilograms

Figure No. 2092Y, 7592Y	NPS	3	4	6	8	10	12	14	16	18	20	24
	DN	80	100	150	200	250	300	350	400	450	500	600
A - End to End		17	18.5	27.75	30	36.25	43	41	54	63	54.5	58
		432	470	705	762	921	1092	1041	1372	1600	1384	1478
E - Center to Top		10	11	16	20.75	25.5	29.25	29.25	34	34	43	43
		254	279	406	527	648	743	743	864	864	1092	1092
H - Equalizer Clearance		9	10	10.75	12.75	15.75	16.5	16.5	19.5	19.5	28	28
		229	254	273	324	400	419	419	495	495	711	711
Weight		140	200	480	900	1750	2525	2525	5550	5850	6700	11,200
		64	91	218	408	794	1145	1145	2517	2654	3039	5080

Refer to page 116 for materials of construction.

Refer to pages 203 through 238 for the applicable pressure ratings.

## Check Valves, Class 1500

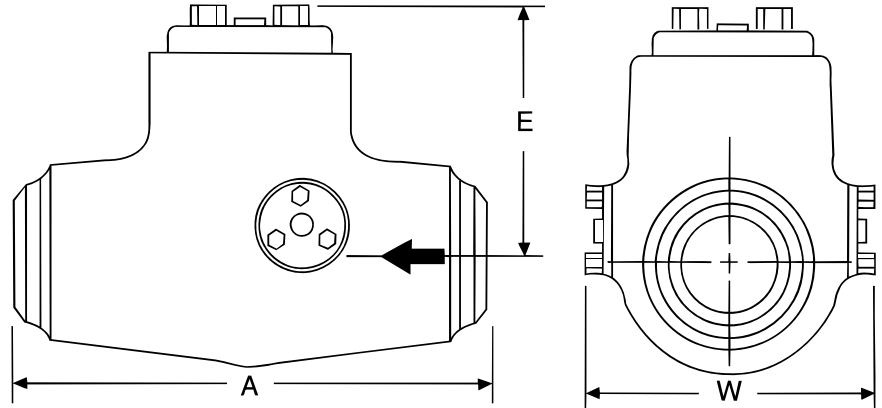
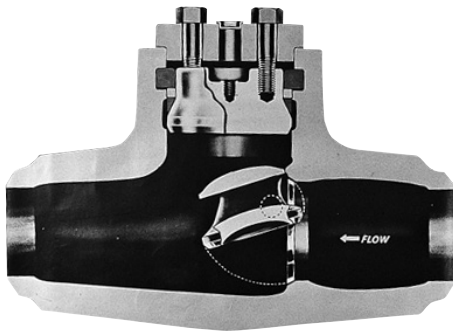

1570Y

### Standard Features

- Bodies and covers are cast steel (WCB, WCC, WC9, CF8M)
- Pressure-seal cover
- Y Pattern
- Integral Stellite seats
- Body-guided disc piston

### Pressure Class 1500 (PN 260)

Fig. No.		Type	Ends	NPS (DN)
STD CL	SPL CL			
1570Y	2070Y	Tilting-Disc	Butt Weld	2½ (65) thru 24 (600)

### Dimensions – Tilting-Disc

Black numerals are in inches and pounds  
Colored numerals are in millimeters and kilograms

Figure No. 1570Y, 2070Y	NPS	2½*	3*	4*	6	8	10
	DN	65	80	100	150	200	250
A - End to End (Welding)		12	12	12	22	28	34
		305	305	305	559	711	864
E - Center to Top		7.25	7.25	7.25	9.25	11	13
		184	184	184	235	279	330
W - Width		10.5	10.5	10.5	16.5	16.75	20.5
		267	267	267	419	425	521
Weight (Welding)		90	90	95	460	600	1005
		41	41	43	209	272	456

\* Spiral-wound hinge pin gaskets; hinge pin torsion spring not required.

Figure No. 1570Y	NPS	12	14	16	18	20	24
	DN	300	350	400	450	500	600
A - End to End (Welding)		42	40.5	47	53	51.5	58
		1067	1029	1194	1346	1308	1473
E - Center to Top		15.75	15.75	18.75	18.75	23	36
		400	400	476	476	584	914
W - Width		26.5	26.5	29	29	37.5	55
		673	673	737	737	953	1397
Weight (Welding)		1520	1550	3280	3590	4600	10,300
		689	703	1487	1628	2087	4672

Refer to page 116 for materials of construction.

Refer to pages 203 through 238 for the applicable pressure ratings.

---

Page intentionally left blank

## **Anchor/Darling Check Valves**

---

Page intentionally left blank



## Features and Description of 800 and 1878 Series Piston Check Valves

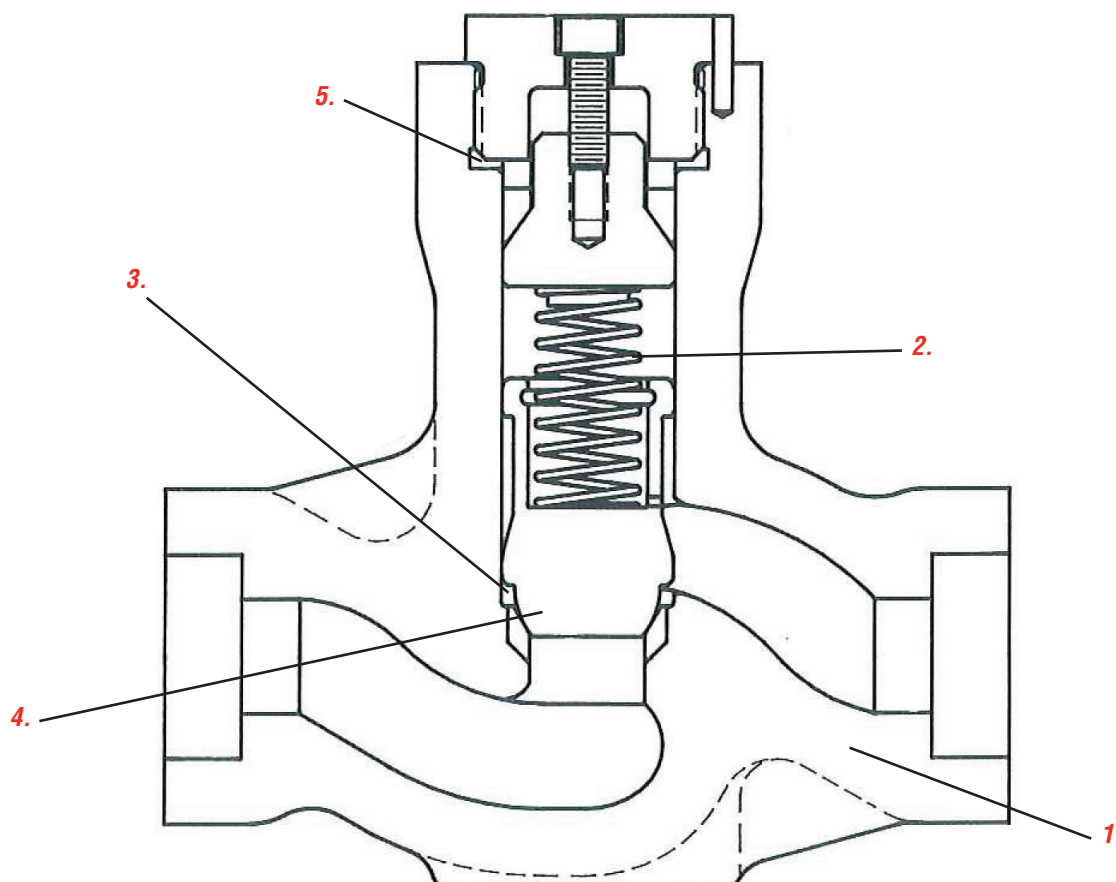

**1. A compact, rugged,** low-profile, precision cast body utilizes the latest investment casting technology. The valve offers smooth flow passages (not available in forged body designs).

**2. Valves are stocked** with spring-loaded discs that provide a 5 psi cracking pressure.

**3. Designed for Low Leakage Rate Testing (LLRT)** and stocked with EPR/EPDM resilient seated discs. A hard-seated disc is available for high-temperature applications.

**4. The lightweight disc** minimizes pressure drop. Valves are stocked with disc and seat ring of solid non-Cobalt material. Solid Cobalt chrome discs and seats (AMS-5387) can also be provided on special order.

**5. Designed to meet ALARA programs,** the valve is made to greatly reduce worker exposure. The ADVanseal® design requires no grinding, cutting or welding.

## Parts Specification List for Anchor/Darling 800 and 1878 Piston Check Valves

### Standard Features

- Available body material  
SA216-WCB  
SA351-CF8M

**Anchor/Darling 1878 Series piston check valves for nuclear service are normally furnished in Class 1878. Other interpolated pressure classes are also available on application.**

Parts shown are not applicable to all 1878 Series valves. Construction and materials for nuclear valves may vary depending upon customer design specifications. For a complete, accurate and itemized description of a particular valve, contact your local Flowserve valves sales representative.

Description	ASME/ASTM No.	ASME/ASTM No.
Body	SA216-WCB	SA351-CF8M
Bonnet	SA105	SA479-316
Disc	SA564-630-1075	SA564-630-1075
Seat	A276-S21800A	A276-S21800A
Bonnet Retainer	SA479-316	SA479-316
Spring	Inconel X	Inconel X

## 800 Series Piston Check Valves, Class 800

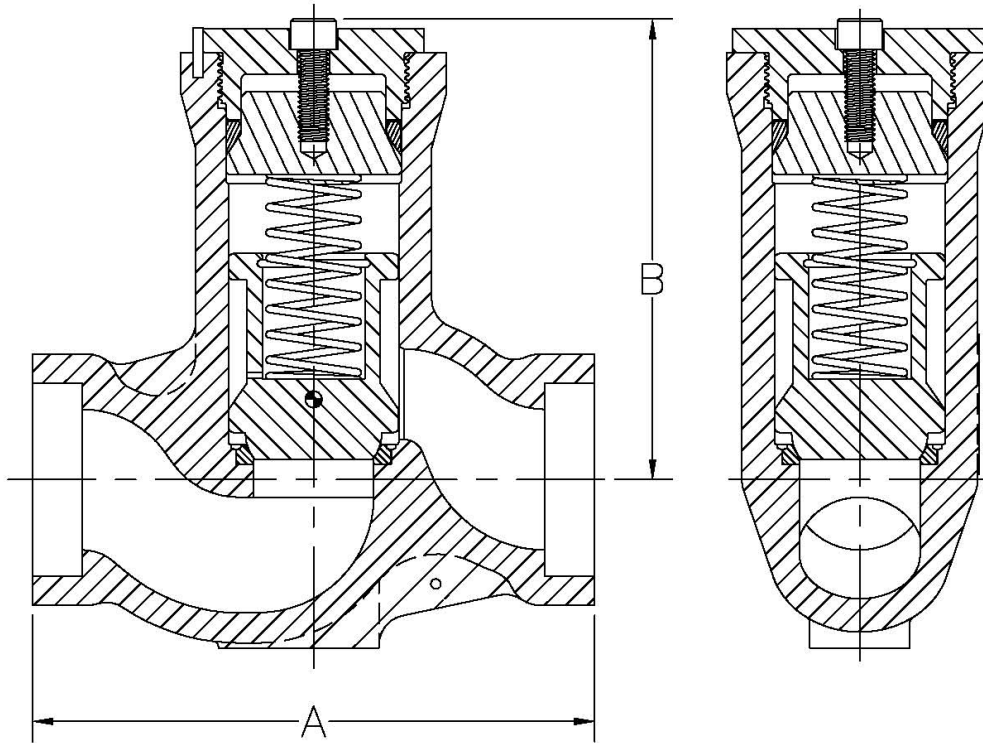

### Standard Features

- Pressure Class 800 (Intermediate) (WCB, CF8M)
- Designed for long life
- Positive low pressure sealing
- Optional resilient seating for LLRT applications
- Contoured flow path provides maximum Cv
- ADVanseal® pressure sealing system
- Investment castings
- Quick disassembly/reassembly

### Pressure Class 800 (PN 130)

Fig. No.	Type	Ends	NPS (DN)
UPC78S	Piston Check	Socket Weld	½ (15) thru 2 (50)
UPC78U	Piston Check	Butt Weld	½ (15) thru 2 (50)

### Dimensions – T Pattern

Black numerals are in inches and pounds  
Colored numerals are in millimeters and kilograms

Figure No. UPC78S, UPC78U	NPS	½	¾	1	2
	DN	15	20	25	50
A		3.6	3.7	4.4	7
B		3.8	3.8	4.3	8.7
Weight Approx. (lbs.)		4	4	6	15
Cv		4.5	4.5	8	36

\* Reduced ports  
Refer to page 130 for materials of construction.  
Refer to pages 203 through 238 for the applicable pressure ratings.

## Series 1878 Piston Check Valves, Class 1878

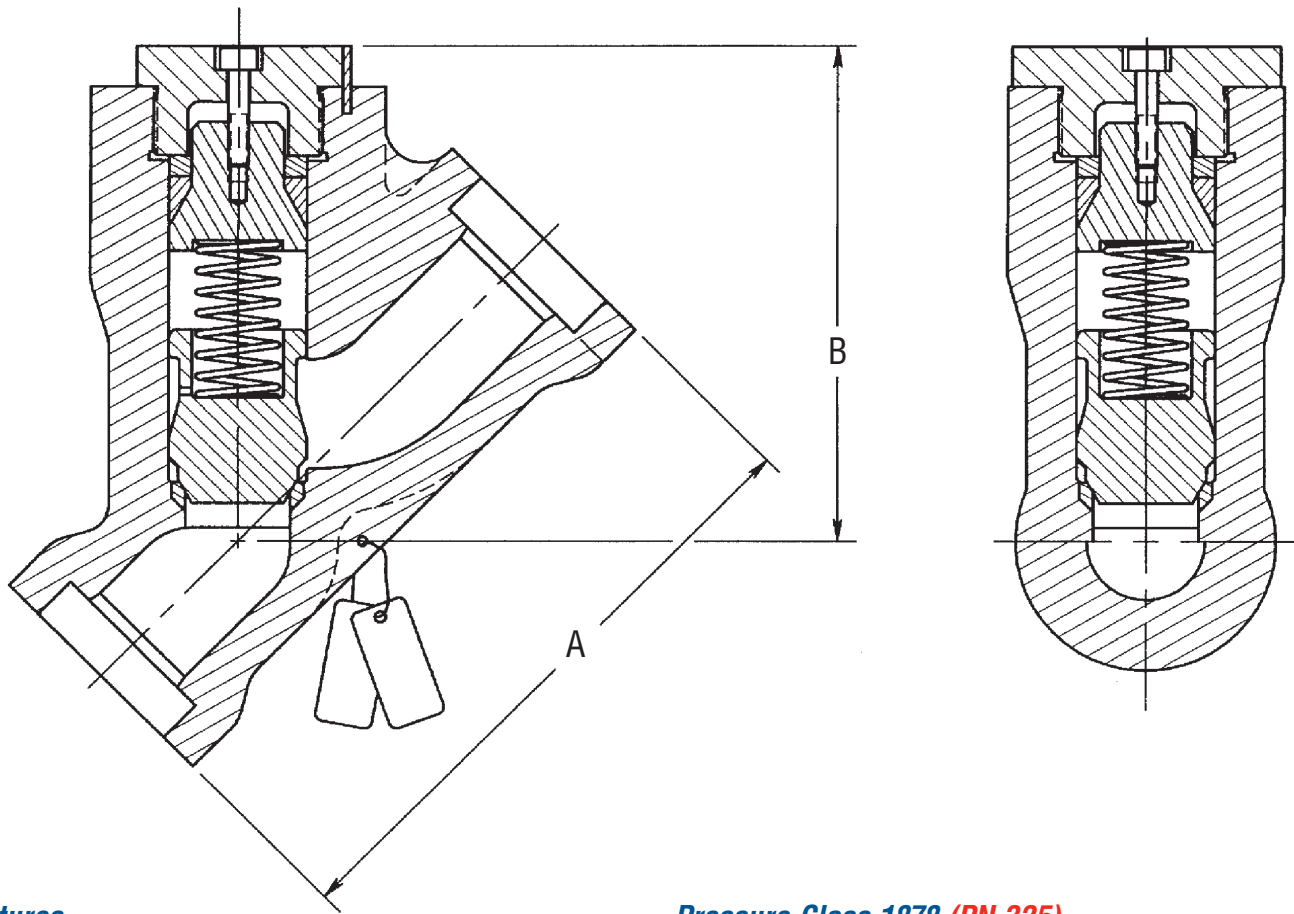

### Features

- Pressure Class 1878 (Intermediate) (WCB, CF8M)
- Contoured flow path provides maximum Cv
- Quick disassembly
- Investment casting
- Non-cobalt hardfacing, standard
- Optional resilient seating for LLRT applications

### Pressure Class 1878 (PN 325)

Fig. No.	Type	Ends	NPS (DN)
NYP79S	Piston Check	Socket Weld	½ (15) thru 2 (50)
NYP79U	Piston Check	Butt Weld	½ (15) thru 2 (50)

- ADVanseal® pressure sealing system
- Positive low pressure sealing
- Designed for long wear

### Dimensions – Y Pattern

Figure No. NYP79S/NYP79U	NPS	½	¾	1	1½	2*	2
	DN	15	20	25	40	50	50
A		5.5	5.5	5.5	7.0	8.5	8.5
		140	140	140	178	216	216
B		4.7	4.7	4.7	6.1	6.1	6.8
		119	119	119	155	155	173
Weight Approx (lbs.)		13	13	13	26	26	30
		5.9	5.9	5.9	11.8	11.8	13.6
Cv		14	16	16	48	48	76

Black numerals are in inches and pounds  
Colored numerals are in millimeters and kilograms

\* Reduced ports

Refer to page 130 for materials of construction.

Refer to pages 203 through 238 for the applicable pressure ratings.

## Series 1878 Piston Check Valves, Class 1878

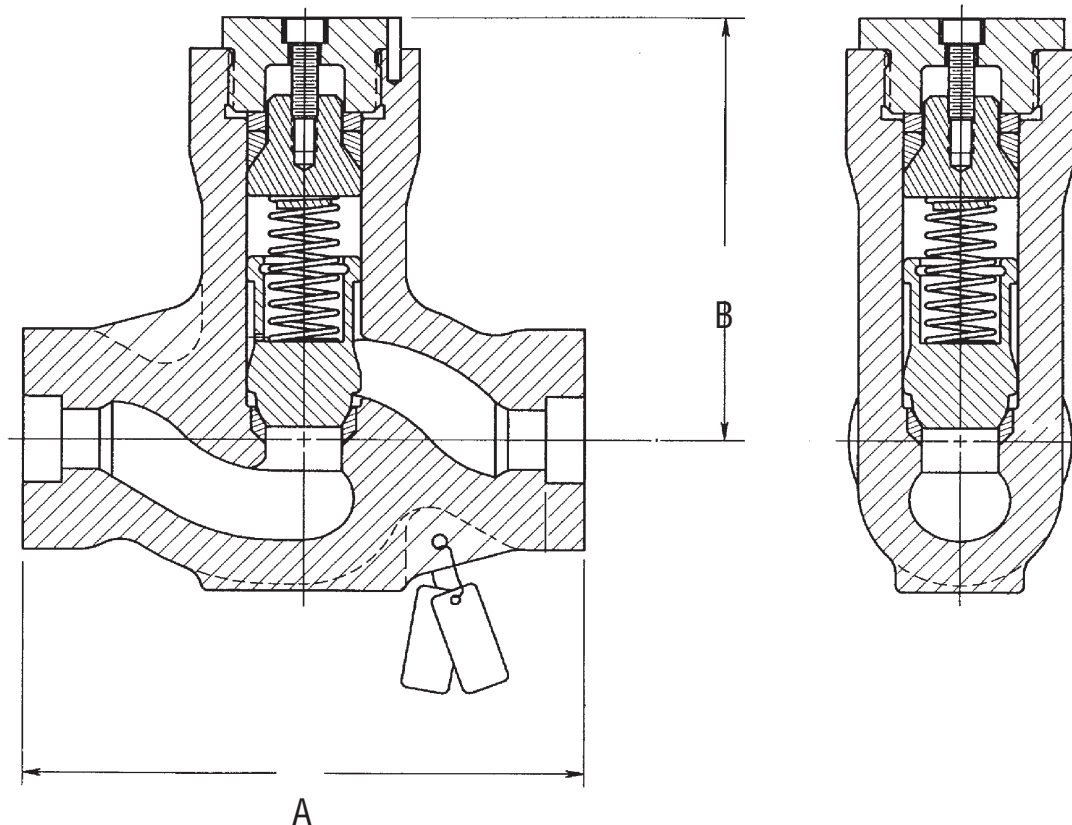

### Features

- Pressure Class 1878 (Intermediate) (WCB, CF8M)
- Designed for long wear
- Positive low pressure sealing
- Optional resilient seating for LLRT applications
- Contoured flow path provides maximum Cv
- ADVanseal® pressure sealing system
- Investment casting
- Quick disassembly

### Pressure Class 1878 (PN 325)

Fig. No.	Type	Ends	NPS (DN)
NPC78S	Piston Check	Socket Weld	½ (15) thru 2 (50)
NPC78U	Piston Check	Butt Weld	½ (15) thru 2 (50)

### Dimensions – T Pattern

Black numerals are in inches and pounds  
Colored numerals are in millimeters and kilograms

Figure No. NPC78S/NPC78U	NPS	½	¾	1	1½	2*	2
	DN	15	20	25	40	50	50
A		5.5	5.5	5.5	8.5	8.5	8.5
		140	140	140	216	216	216
B		4.2	4.2	4.2	5.4	5.4	5.9
		107	107	107	137	137	150
Weight Approx (lbs.)		11	11	11	24	24	28
		5.0	5.0	5.0	10.9	10.9	12.7
Cv		7	8	8	24	24	38

\* Reduced ports

Refer to page 130 for materials of construction.

Refer to pages 203 through 238 for the applicable pressure ratings.

## Features and Description of 1878 Series Swing-Check Valves

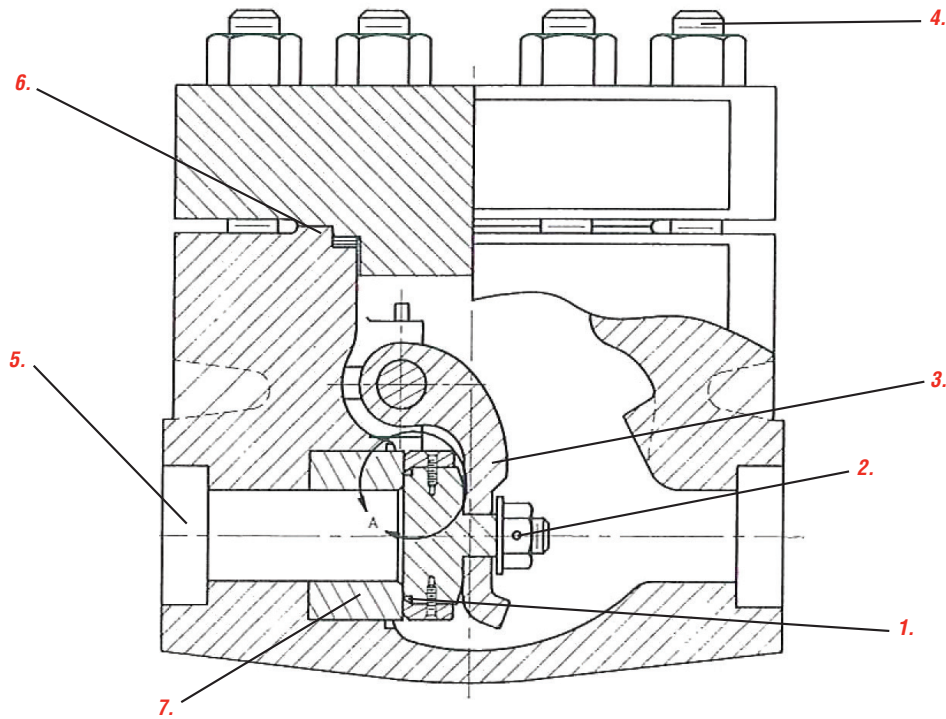

### 1. Designed for Local Leakage Rate

**Testing** (LLRT) and stocked with EPR resilient seated discs. A hard-seated disc is available for high-temperature applications.

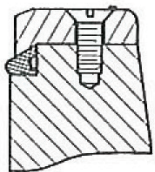

**Enlarged Detail A  
Resilient Seated Disc**

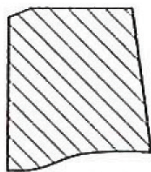

**Enlarged Detail A  
Hard Seated Disc**

- EPR resilient seating material qualified for radiation environments:
  - 2.2X10<sup>7</sup> RADS (integrated dosage)
  - 420°F for 6 years in steam or water
  - 450°F short-term service
  - 5-year shelf life
- Disc SA564-630 heat treated at 1075°F for
  - high hardness to resist abrasion
  - available with metal seat or dual seat as shown

**2. Disc nut fastener** is locked in position to prevent loosening during operation.

**3. Disc arms is hinge mounted on pads**, readily accessible for adjustment and replacement.

**4. Studs threaded in body** to simplify and reduce time for disassembly. The (8) studs for 1½" and 2" valves and (6) studs for ½" through 1" valves provide uniform compression of the spiral-wound gasket, to ensure positive joint sealing.

**5. Clear flow path design** minimizes pressure drop.

**6. Built-in compression stop** ensures proper gasket compression.

**7. Valves are stocked** with disc and seat ring of solid non-Cobalt material. Solid Cobalt chrome seat (AMS-5387) can also be provided on special order.

## Parts Specification List for Anchor/Darling 1878 Swing-Check Valves

### Standard Features

- Available body material  
SA216-WCB  
SA351-CF8M

**Anchor/Darling 1878 Series swing-check valves for nuclear service are normally furnished in Class 1878. Other interpolated pressure classes are also available on application.**

Parts shown are not applicable to all 1878 valves. Construction and materials for nuclear valves may vary depending upon customer design specifications. For a complete, accurate and itemized description of a particular valve, contact your local Flowserve valves sales representative.

Description	ASME/ASTM No.	ASME/ASTM No.
Body	SA216-WCB	SA351-CF8M
Bonnet	SA216-WCB	SA351-CF8M
Hinge	A351-CF8M	A351-CF8M
Disc	SA564-630-1075	SA564-630-1075
Seat	A276-S21800A	A276-S21800A
Studs	SA193-B7	SA193-B7

## Series 1878 Swing-Check Valves – Bolted Bonnet, Class 1878

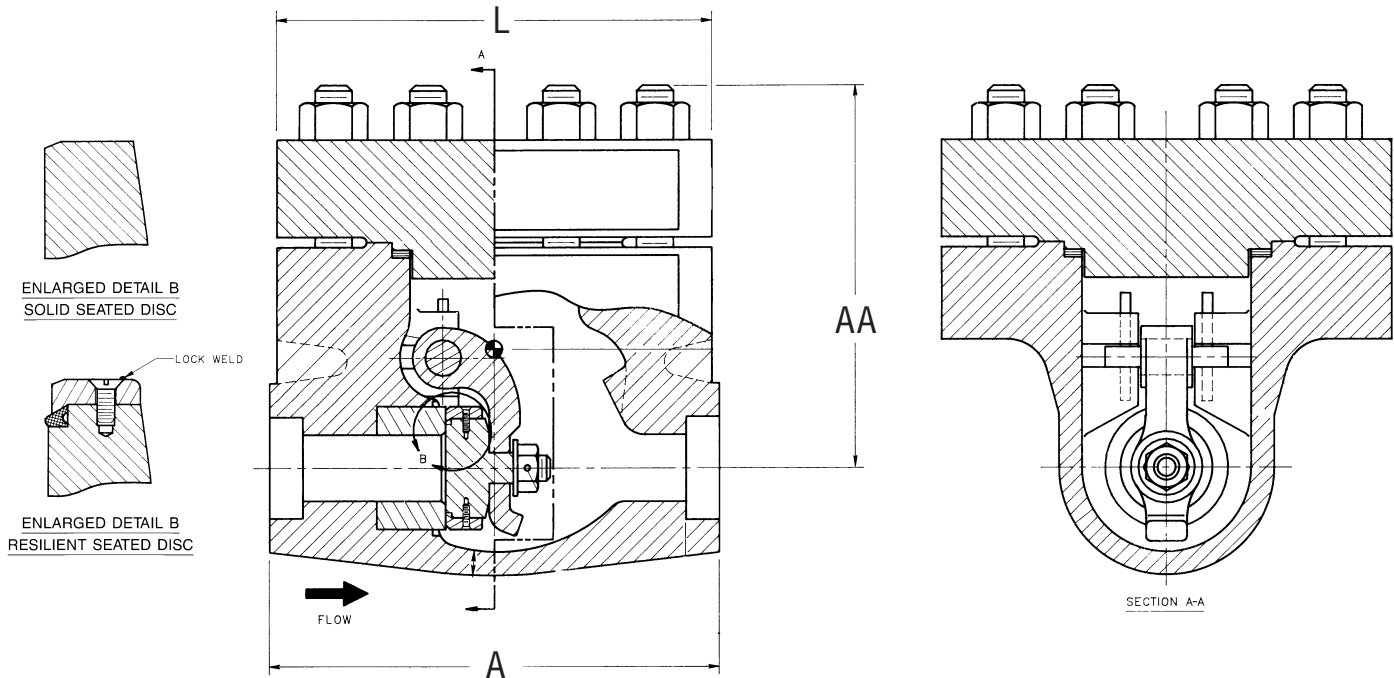

### Features

- Pressure Class 1878 (Intermediate) (WCB, CF8M)
- Tight sealing
- Optional resilient seating for LLRT applications
- Minimum pressure drop
- Installation in vertical lines (with flow upward) or horizontal lines
- Ease of maintenance

### Pressure Class 1878 (PN 325)

Fig. No.	Type	Ends	NPS (DN)
NSC51S	Swing Check	Socket Weld	½ (15) thru 2 (50)
NSC51U	Swing Check	Butt Weld	½ (15) thru 2 (50)

- Internal disc assembly readily removed
- Low Delta P to open
- Disc arm tail stop

### Dimensions

Black numerals are in inches and pounds  
Colored numerals are in millimeters and kilograms

Figure No. NPC51S/NPC51U	NPS	½	¾	1	1½	2
	DN	15	20	25	40	50
A		5.5	5.5	5.5	8.5	8.5
		140	140	140	216	216
L		5.8	5.8	5.8	8	8
		147	147	147	203	203
AA		5.0	5.0	5.0	7.0	7.0
		127	127	127	178	178
Weight Approx (lbs.)		25	25	25	70	70
		11.3	11.3	11.3	31.8	31.8
Cv		3	8	14	55	85

Cv is based on sufficient flow to maintain disc in full open position.  
Refer to page 135 for materials of construction.  
Refer to pages 203 through 238 for the applicable pressure ratings.



## Series 1878 Swing-Check Valves – Pressure Seal Bonnet, Class 1878

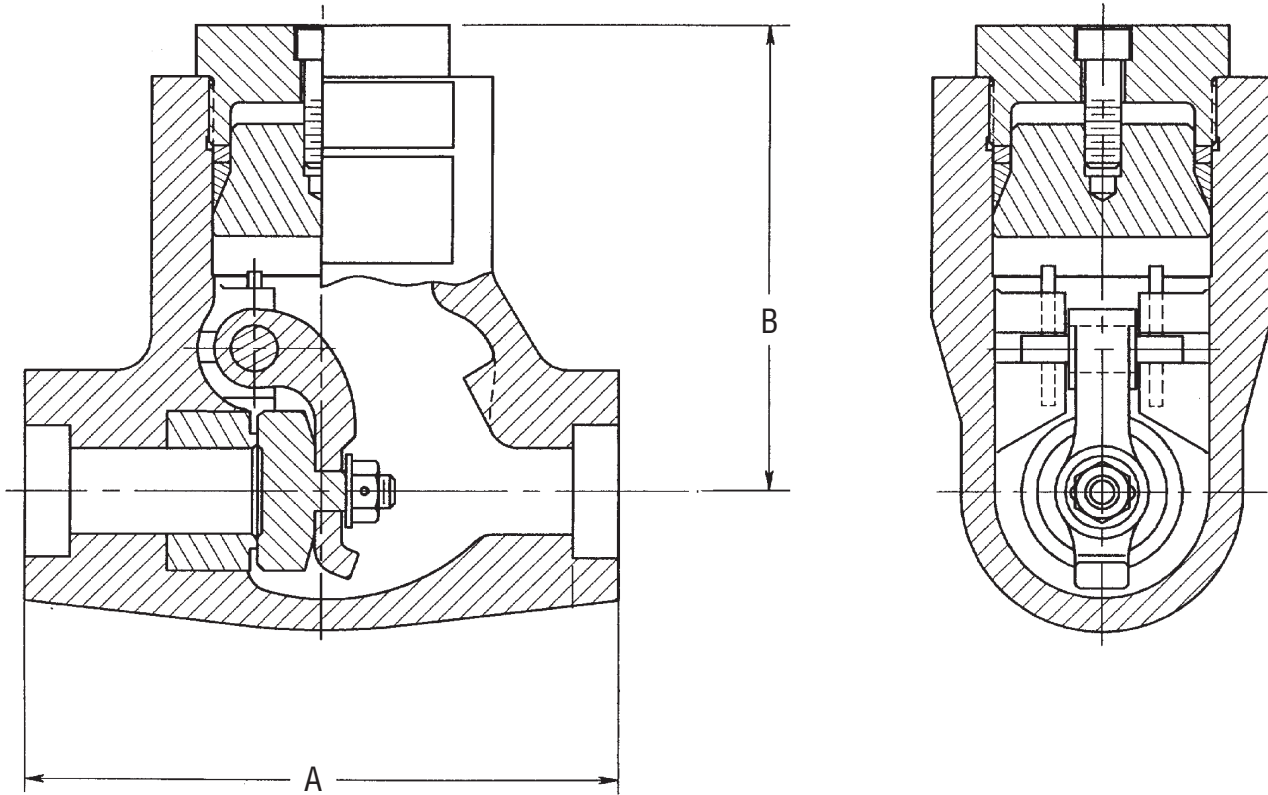

### Features

- Pressure Class 1878 (Intermediate) (WCB, CF8M)
- Tight sealing
- Minimum pressure drop
- One-piece investment cast body
- Low Delta P to open
- Solid, non-cobalt seat and disc

### Pressure Class 1878 (PN 325)

Fig. No.	Type	Ends	NPS (DN)
NSC58S	Swing Check	Socket Weld	½ (15) thru 2 (50)
NSC58U	Swing Check	Butt Weld	½ (15) thru 2 (50)

- Disc arm tail stop
- Optional resilient seating for LLRT applications
- ADVanseal® pressure sealing system

### Dimensions

Black numerals are in inches and pounds  
Colored numerals are in millimeters and kilograms

Figure No. NSC58S/NSC58U	NPS	½	¾	1	1½	2
	DN	15	20	25	40	50
A		5.5	5.5	5.5	8.5	8.5
		140	140	140	216	216
B		4.8	4.8	4.8	6.3	6.3
		122	122	122	160	160
Weight Approx (lbs.)		20	20	20	45	45
		9.1	9.1	9.1	20.4	20.4
Cv		3	8	14	85	85

Other sizes available upon request.

Refer to page 135 for materials of construction.

Refer to pages 203 through 238 for the applicable pressure ratings.

## Features and Description of Anchor/Darling Check Valves

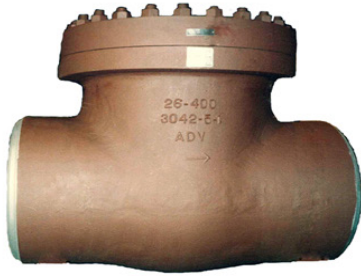

**Swing Check**

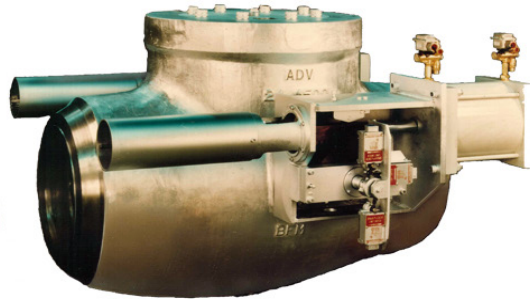

**Tilting-Disc Check**



**Angle - Lift Check**

Flowserve Anchor/Darling's years of experience in designing and manufacturing various types of custom-engineered valves ensures you of receiving the most suitable valve for your specific service. Available designs include swing, tilting disc and lift check valves. To provide even greater flexibility, valves can be furnished with either

bolted bonnet or pressure seal type bonnets and flanged or weld ends. Anchor/Darling regularly supplies valves from 150 to 4500 pressure class ratings in carbon steel and a wide range of special alloys.

In addition to "simple" reverse flow protection, Anchor/Darling check valves can

be designed to provide numerous auxiliary modes of operation. Many of today's sophisticated applications require that the valves incorporate assurance of operability and controlled closure. Our engineering staff is available to assist the customer in determining the type of valve and actuator that best fulfills the design requirements.

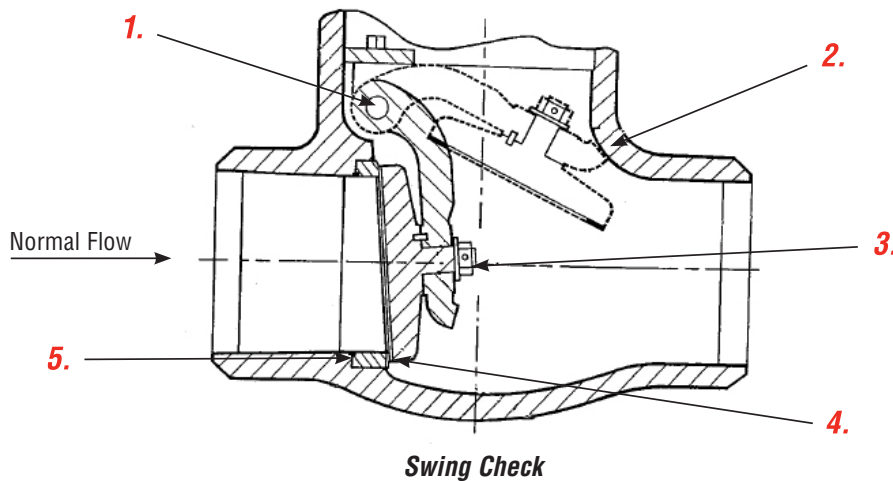

**Swing Check**

- 1. **No body penetration.** Hinge is mounted on pads, readily accessible for adjustment and replacement.
- 2. **Extended hinge,** which takes up normal flow impact. Prevents disc contact with body and disc pin breakage.

- 3. **Fastener locked in position** to prevent loosening during operation.
- 4. **Inclined seat** to provide assurance of closure even in the absence of reverse flow.

- 5. **Crowned sealing surface** achieves precise unit loading for a tight seal with minimal force.

## Features and Description of Flowserve – Anchor/Darling Check Valves

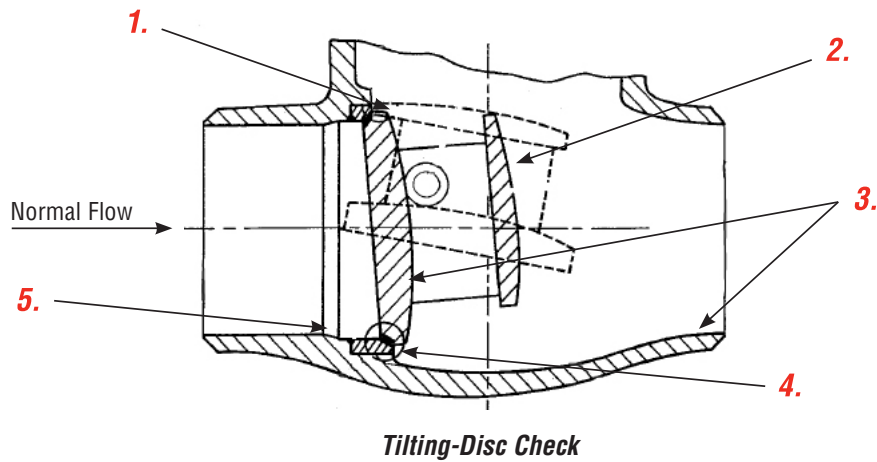

- 1. **Disc stop impacts body** away from sealing surfaces; it also maintains disc open in the best position to minimize pressure drop.
- 2. **Hydrofoil profile** maintains disc stability while being lifted by hydrodynamic forces at any flow, including pulsating.
- 3. **Cast bodies and disc** permit the internal flow passages to be designed with smooth, large radius curves.
- 4. **Differential seat angles** between disc and seat ring ensures better seal with low seating force.
- 5. **Seat rings are seal welded** to minimize distortion from body stress while retaining ease of replacement.

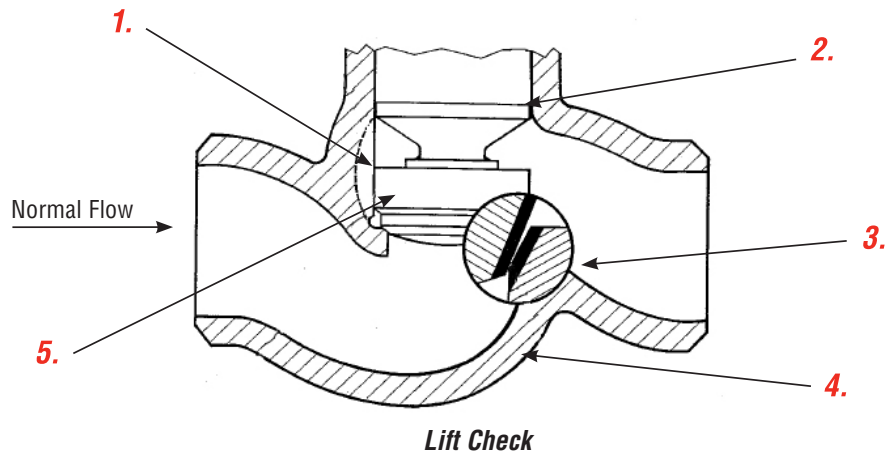

- 1. **Full body guides** ensure correct seat alignment.
- 2. **Plug skirt** prevents plug from cocking even under turbulent flow conditions.
- 3. **Differential mating angles** between plug and seat ring ensure tight seal with low seating force.
- 4. **Cast bodies** permit the internal flow passage to be designed with large radius curves.
- 5. **Swivel plug** ensures proper seat alignment and tight seal.



## Parts Specification List for Flowserve Anchor/Darling Tilting-Disc Check Valves

This is not a complete list. Construction and materials will vary between sizes and pressure classes and may be changed without notice. For a complete, accurate and itemized description of a particular valve, contact your Flowserve valves sales representative.

Description <sup>(1)</sup>	ASME/ASTM No.	ASME/ASTM No.	ASME/ASTM No.	ASME/ASTM No.	ASME/ASTM No.
<b>Body</b>	SA-216 Grade WCB	SA-216 Grade WCC	SA-217 Grade WC9	SA-351 Grade CF8	SA-351 Grade CF8M
<b>Bonnet Cap</b>	SA-515 Grade 70	A-105	A-182 Grade F22	SA-240 Grade 304	SA-240 Grade 316
<b>Disc</b>	SA-216 Grade WCB	SA-105 —	SA-182 Grade F22	SA-351 Grade CFB	SA-351 Grade CF8M
<b>Pressure Seal Gasket*</b>	Composite Pressure Seal Gasket				
<b>Bonnet Capscrews or Studs</b>	SA-193 Grade B7	A-193 Grade B7	A-193 Grade B7	SA-193 Grade B7	SA-193 Grade B7
<b>Bonnet Nuts</b>	A-194 Grade 2H	A-194 Grade 2H	A-194 Grade 2H	A-194 Grade 2H	A-194 Grade 2H
<b>Hinge Pin</b>	A-582 Grade 416T	A-182 Grade F6aCL4	A-565 Grade 616 HT	A-582 Grade 416T	A-582 Grade 416T
<b>Hinge Pin Bolts</b>	A-193 Grade B7	A-193 Grade B7	A-193 Grade B16	A-453 Grade 660B	A-453 Grade 660B
<b>Hinge Pin Retainer</b>	SA-515 Grade 70	A-105 —	A-182 Grade F22	SA-240 Grade 304	SA-240 Grade 316

\*Other material grades available on application.

## Parts Specification List for Flowserve Anchor/Darling Swing-Check Valves

This is not a complete list. Construction and materials will vary between sizes and pressure classes and may be changed without notice. For a complete, accurate and itemized description of a particular valve, contact your Flowserve valves sales representative.

Description <sup>(1)</sup>	ASME/ASTM No.	ASME/ASTM No.	ASME/ASTM No.
<b>Body</b>	SA-216 Grade WCB	SA-351 Grade CF8	SA-351 Grade CF8M
<b>Bonnet Cap</b>	SA-515 Grade 70	SA-240 Grade F304	SA-240 Grade 316
<b>Hinge</b>	A-216 Grade WCB	A-351 Grade CF8	A-351 Grade CF8M
<b>Disc</b>	SA-105 —	SA-182 Grade F304	SA-182 Grade F316
<b>Pressure Seal Gasket*</b>	Composite Pressure Seal Gasket		
<b>Bonnet Capscrews or Studs</b>	A-193 Grade B7	A-193 Grade B7	A-193 Grade B7
<b>Bonnet Cover Nuts</b>	A-194 Grade 2H	A-194 Grade 2H	A-194 Grade 2H
<b>Hinge Pin</b>	A-479 Grade 316	A-479 Grade 316	A-564 Grade 630-1075
<b>Hinge Pin Retainer</b>	SA-216 Grade WCB	SA-182 Grade F316	SA-240 Grade 316

\*Other material grades available on application.

## Parts Specification List for Flowserve Anchor/Darling Lift-Check Valves

This is not a complete list. Construction and materials will vary between sizes and pressure classes and may be changed without notice. For a complete, accurate and itemized description of a particular valve, contact your Flowserve valves sales representative.

Description <sup>(1)</sup>	ASME/ASTM No.	ASME/ASTM No.	ASME/ASTM No.
<b>Body/Cover</b>	SA-216 Grade WCB	SA-351 Grade CF8	SA-351 Grade CF8M
<b>Disc</b>	SA-105 —	SA-182 Grade F304	SA-182 Grade F316
<b>Pressure Seal Gasket*</b>	Composite Pressure Seal Gasket		
<b>Cover Capscrews or Studs</b>	A-193 Grade B7	A-193 Grade B7	A-193 Grade B7
<b>Cover Nuts</b>	A-194 Grade 2H	A-194 Grade 2H	A-194 Grade 2H

\*Other material grades available on application.

## Tilting-Disc Check Valves, Class 150

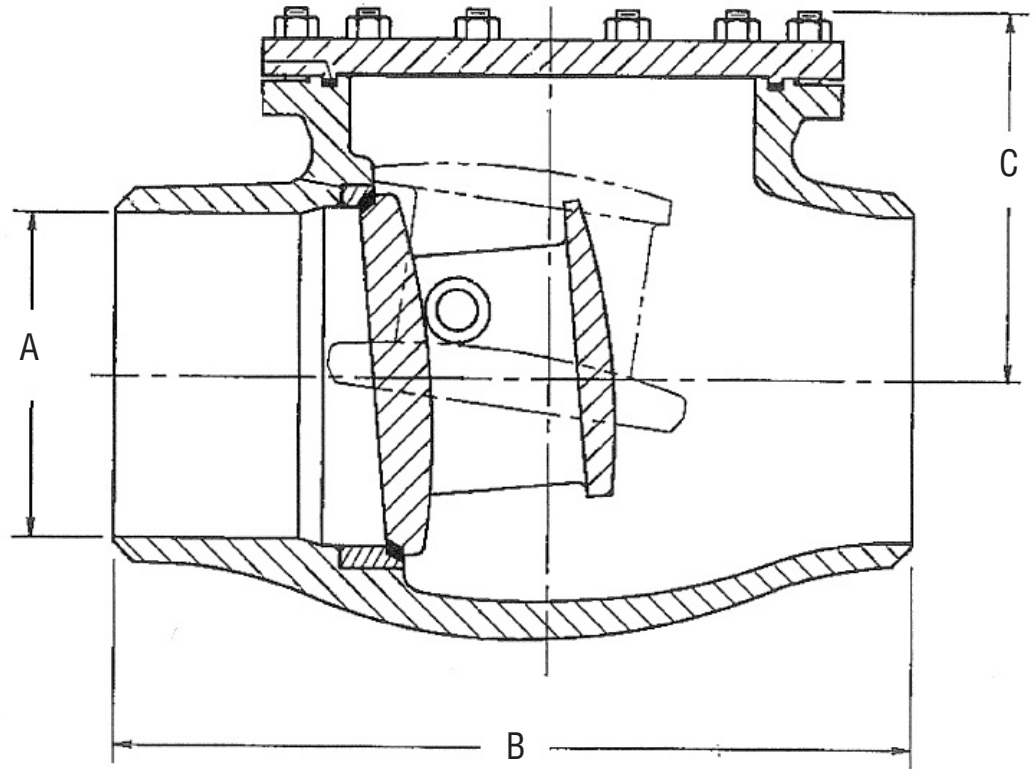

### Standard Features

- Carbon, stainless or special alloys
- Bolted bonnet
- Available Stellite seat and disc
- Easily accessible hinge
- Hydrofoil-style disc maintains stability
- Heavy counterweight ensures fast reaction
- Waterhammer is minimized

### Pressure Class 150 (PN 25)

Fig. No.	Type	Ends	NPS (DN)
BTD63U	Tilting-Disc Check	Butt Weld	2½ (65) thru 24 (600)
BTD63C	Tilting-Disc Check	Flanged	2½ (65) thru 24 (600)

### Dimensions

Black numerals are in inches and pounds  
Colored numerals are in millimeters and kilograms

Figure No. BTD63U/BTD63C	NPS	2½	3	4	6	8	10	12	14	16	18	20	24
	DN	65	80	100	150	200	250	300	350	400	450	500	600
A		2.5	3	4	6	8	10	12	13.3	16.3	17.3	19.3	23.3
		64	76	102	152	203	254	305	338	414	439	490	592
B		8.5	9.5	11.5	14	19.5	12.5	27.5	31	34	38.5	38.5	44
		216	241	292	356	495	622	699	787	864	978	978	1,118
C		6.5	7	7.5	9	10	12.5	13.5	15	17.5	18	21	23
		165	178	191	229	254	318	343	381	445	457	533	584
Weight Approx (lbs.)		55	75	110	200	305	480	625	945	1,210	1,675	2,440	2,920
		25.9	34.0	49.9	90.7	138.3	217.7	283.5	428.7	548.9	759.8	1,106.8	1,324.5
Cv		175	275	500	1,175	2,200	3,525	5,175	6,400	8,625	11,200	14,075	20,850

Refer to page 140 for materials of construction.

Refer to pages 203 through 238 for the applicable pressure ratings.

## Tilting-Disc Check Valves, Class 300

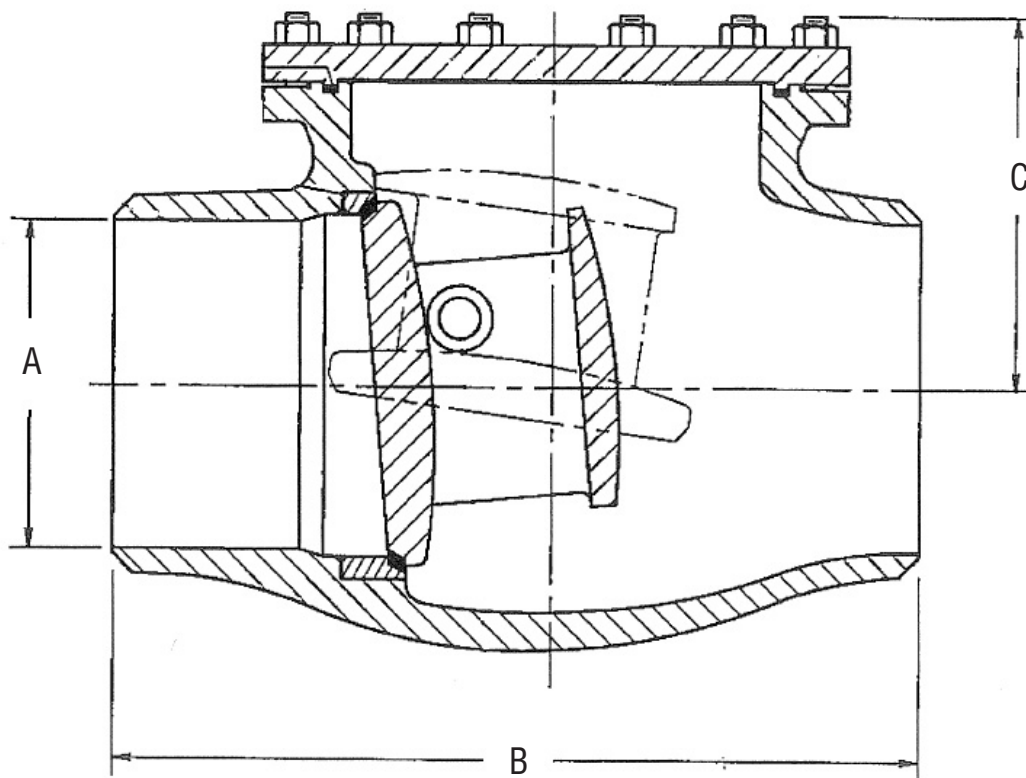

### Standard Features

- Carbon, stainless or special alloys
- Bolted bonnet
- Available Stellite seat and disc
- Easily accessible hinge
- Hydrofoil-style disc maintains stability
- Heavy counterweight ensures fast reaction
- Waterhammer is minimized

### Pressure Class 300 (PN 50)

Fig. No.	Type	Ends	NPS (DN)
CTD63U	Tilting-Disc Check	Butt Weld	2½ (65) thru 24 (600)
CTD63C	Tilting-Disc Check	Flanged	2½ (65) thru 24 (600)

### Dimensions

Black numerals are in inches and pounds  
Colored numerals are in millimeters and kilograms

Figure No. CTD63U/CTD63C	NPS	2½	3	4	6	8	10	12	14	16	18	20	24
	DN	65	80	100	150	200	250	300	350	400	450	500	600
A		2.5	3	4	6	8	10	12	13.3	15.3	17	19	23
		64	76	102	152	203	254	305	338	389	432	483	584
B		11.5	12.5	14	17.5	21	24.5	28	33	34	38.5	40	44
		292	318	356	445	533	600	711	838	864	978	1,016	1,118
C		6.5	7	7.5	10	11.5	13.5	17.5	18	19	20	21.5	23
		165	178	191	254	292	343	445	457	483	508	546	584
Weight Approx (lbs.)		70	90	190	375	440	690	905	1,135	1,315	1,930	2,635	3,730
		31.8	40.8	86.2	170.1	199.6	313.0	410.5	514.8	596.5	875.4	1,195.2	1,691.9
Cv		175	275	500	1,175	2,200	3,525	5,175	6,400	8,625	10,875	13,700	20,425

Refer to page 140 for materials of construction.

Refer to pages 203 through 238 for the applicable pressure ratings.



## Tilting-Disc Check Valves, Class 600

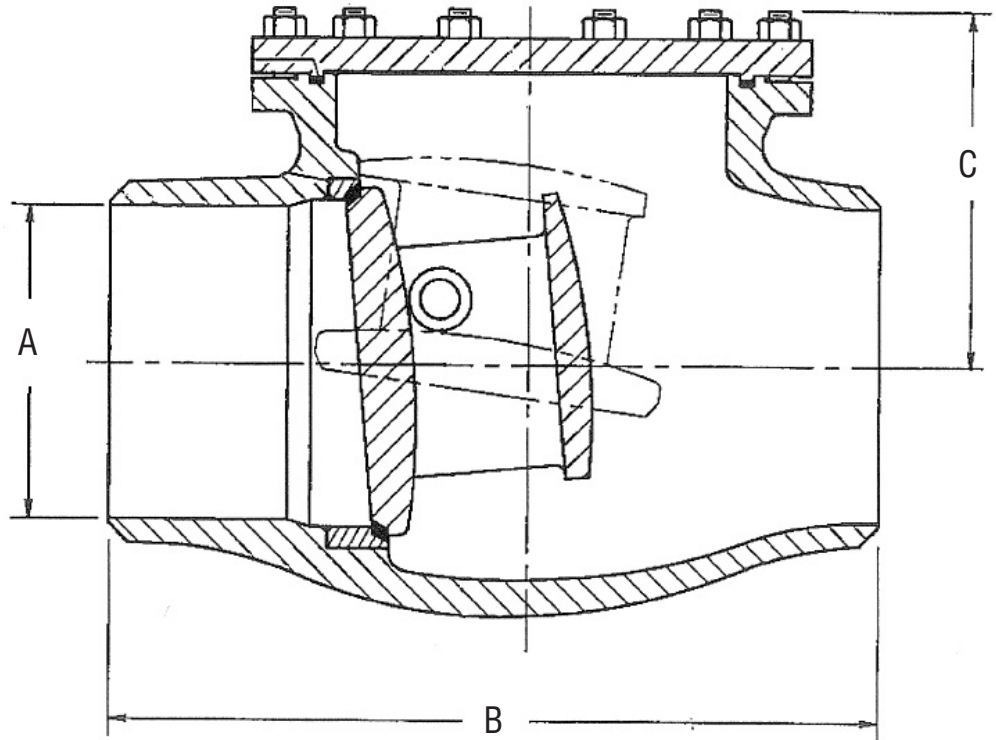

### Standard Features

- Carbon, stainless or special alloys
- Bolted bonnet or pressure seal
- Available Stellite seat and disc
- Easily accessible hinge
- Hydrofoil-style disc maintains stability
- Heavy counterweight ensures fast reaction
- Waterhammer is minimized

### Pressure Class 600 (PN 110)

Fig. No.	Bonnet Type	Type	Ends	NPS (DN)
ETD63U	Bolted Bonnet	Tilting-Disc Check	Butt Weld	2½ (65) thru 24 (600)
ETD63C	Bolted Bonnet	Tilting-Disc Check	Flanged	2½ (65) thru 24 (600)
ETD67U	Pressure Seal	Tilting-Disc Check	Butt Weld	2½ (65) thru 24 (600)
ETD67C	Pressure Seal	Tilting-Disc Check	Flanged	2½ (65) thru 24 (600)

### Dimensions – Tilting-Disc

Black numerals are in inches and pounds  
Colored numerals are in millimeters and kilograms

Figure No. ETD63U/ETD63C, ETD67U/ETD67C	NPS	2½	3	4	6	8	10	12	14	16	18	20	24
	DN	65	80	100	150	200	250	300	350	400	450	500	600
A		2.5	3	4	6	7.9	9.8	11.8	12.9	14.8	16.5	18.3	22
		64	76	102	127	200	248	298	327	375	470	464	559
B		8.5	10	12	18	23	28	32	35	39	43	47	55
		216	254	305	457	584	711	813	889	991	1,092	1,194	1,397
C		5	6	7	9	11	12	13.5	15	17	21	25	27.5
		152	152	178	229	279	305	343	381	432	533	660	699
Weight Approx (lbs.)		55	65	85	125	295	475	820	1,615	2,000	2,700	2,900	3,100
		25	29.5	38.6	56.7	133.8	215.5	372.0	823.3	907.2	1,225	1,315	1,406
Cv		175	275	500	1,275	2,100	3,300	4,900	5,950	7,950	10,100	12,450	18,375

Refer to page 140 for materials of construction.

Refer to pages 203 through 238 for the applicable pressure ratings.

## Tilting-Disc Check Valves, Class 900

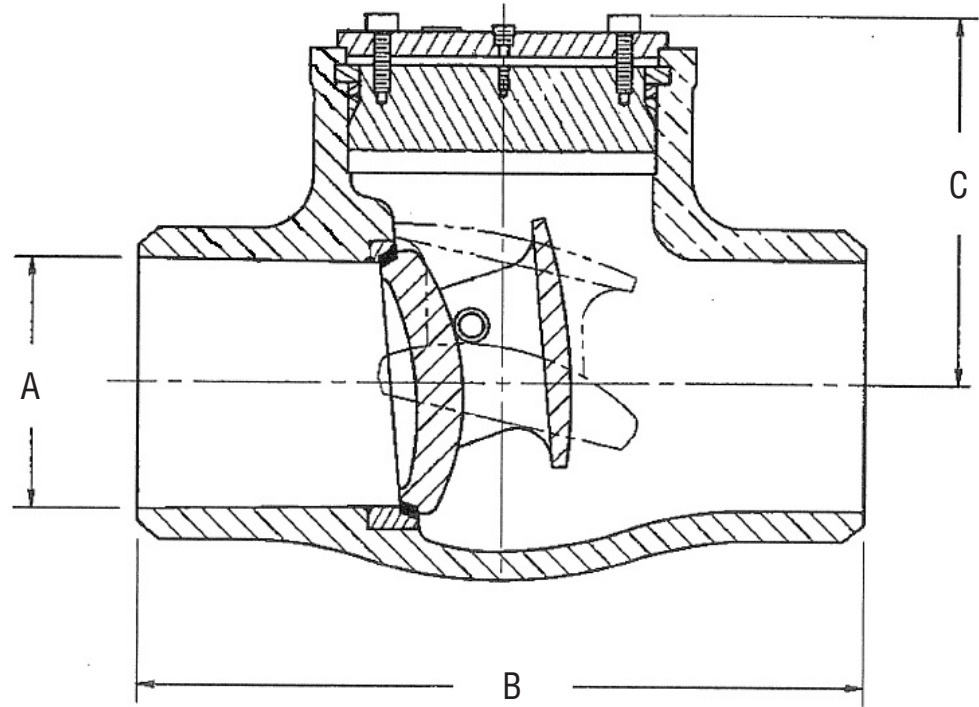

### Standard Features

- Carbon, stainless or special alloys
- Pressure seal
- Available Stellite seat and disc
- Easily accessible hinge
- Hydrofoil-style disc maintains stability
- Heavy counterweight ensures fast reaction
- Waterhammer is minimized

### Pressure Class 900 (PN 150)

Fig. No.	Type	Ends	NPS (DN)
FTD67U	Tilting-Disc Check	Butt Weld	2½ (65) thru 24 (600)
FTD67C	Tilting-Disc Check	Flanged	2½ (65) thru 24 (600)

### Dimensions – Tilting-Disc

Black numerals are in inches and pounds  
Colored numerals are in millimeters and kilograms

Figure No. FTD67U/FTD67C	NPS	2½	3	4	6	8	10	12	14	16	18	20	24
	DN	65	80	100	150	200	250	300	350	400	450	500	600
A		2.3	2.9	3.9	5.8	7.5	9.4	11.1	12.3	14	15.8	17.5	21
		57	73	99	146	191	238	282	311	356	400	445	533
B		10	12	14	20	26	31	38	39	43	46	50	59
		254	305	356	508	660	787	914	991	1,092	1,219	1,270	1,499
C		6	7	7	12	12	13	15	16	21	22.5	25	28
		152	178	178	305	305	330	381	406	533	572	635	711
Weight Approx (lbs.)		75	100	225	350	675	990	1,875	2,315	2,775	3,845	5,250	9,600
		34.0	45.4	102.0	158.8	305.2	449.1	759.8	1,050	1,259	1,744	2,381	4,309
Cv		150	250	450	1,075	1,900	3,050	4,375	5,400	7,150	9,200	11,450	16,750

Refer to page 140 for materials of construction.

Refer to pages 203 through 238 for the applicable pressure ratings.

## Tilting-Disc Check Valves, Class 1500

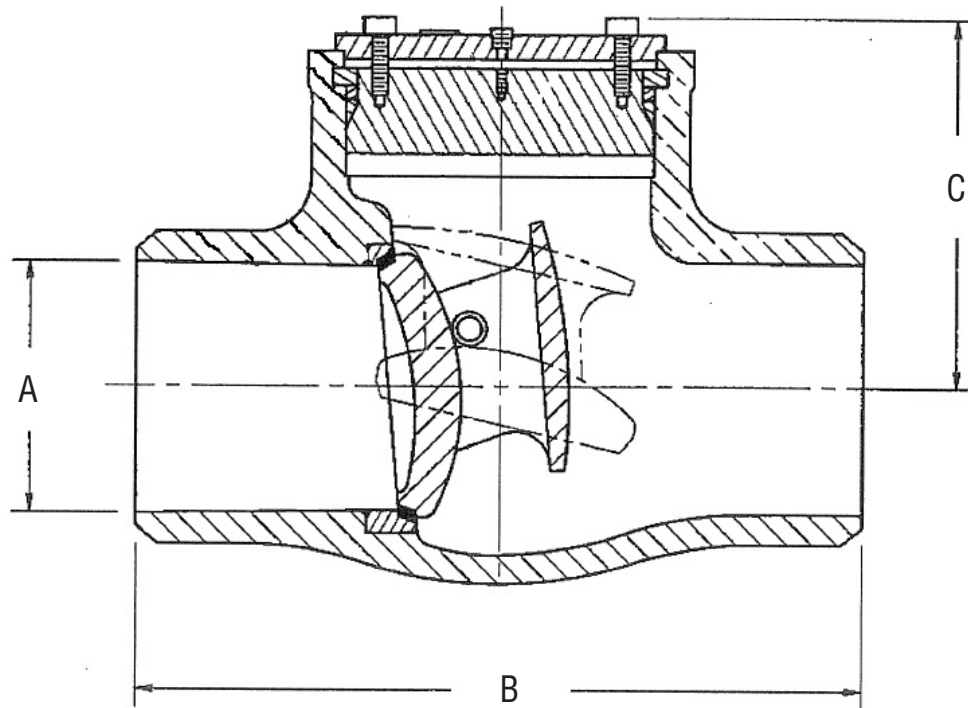

### Standard Features

- Carbon, stainless or special alloys
- Pressure seal
- Available Stellite seat and disc
- Easily accessible hinge
- Hydrofoil-style disc maintains stability
- Heavy counterweight ensures fast reaction
- Waterhammer is minimized

### Pressure Class 1500 (PN 260)

Fig. No.	Type	Ends	NPS (DN)
GTD67U	Tilting-Disc Check	Butt Weld	2½ (65) thru 24 (600)
GTD67C	Tilting-Disc Check	Flanged	2½ (65) thru 24 (600)

### Dimensions

Black numerals are in inches and pounds  
Colored numerals are in millimeters and kilograms

Figure No. GTD67U/GTD67C	NPS	2½	3	4	6	8	10	12	14	16	18	20	24
	DN	65	80	100	150	200	250	300	350	400	450	500	600
A		2.3	2.8	3.6	5.4	7	8.8	10.4	11.4	13	14.6	16.4	19.6
		57	70	92	137	178	222	264	289	330	371	416	498
B		10	12	16	22	28	34	39	42	47	53	58	68
		254	305	406	559	711	864	991	1,067	1,194	1,346	1,473	1,727
C		6	7	8	10	12	15	17	17	18.5	22	24	29.5
		152	178	203	254	305	381	432	432	470	559	610	749
Weight Approx (lbs.)		75	145	280	325	950	1,130	2,080	2,820	3,750	4,350	8,510	11,600
		34.0	65.8	127.0	147.4	430.9	512.6	943.5	1,279	1,701	1,973	3,860	5,262
Cv		150	225	400	925	1,600	2,575	3,675	4,525	6,000	7,700	9,725	14,400

Refer to page 140 for materials of construction.

Refer to pages 203 through 238 for the applicable pressure ratings.

## Swing-Check Valves, Class 150

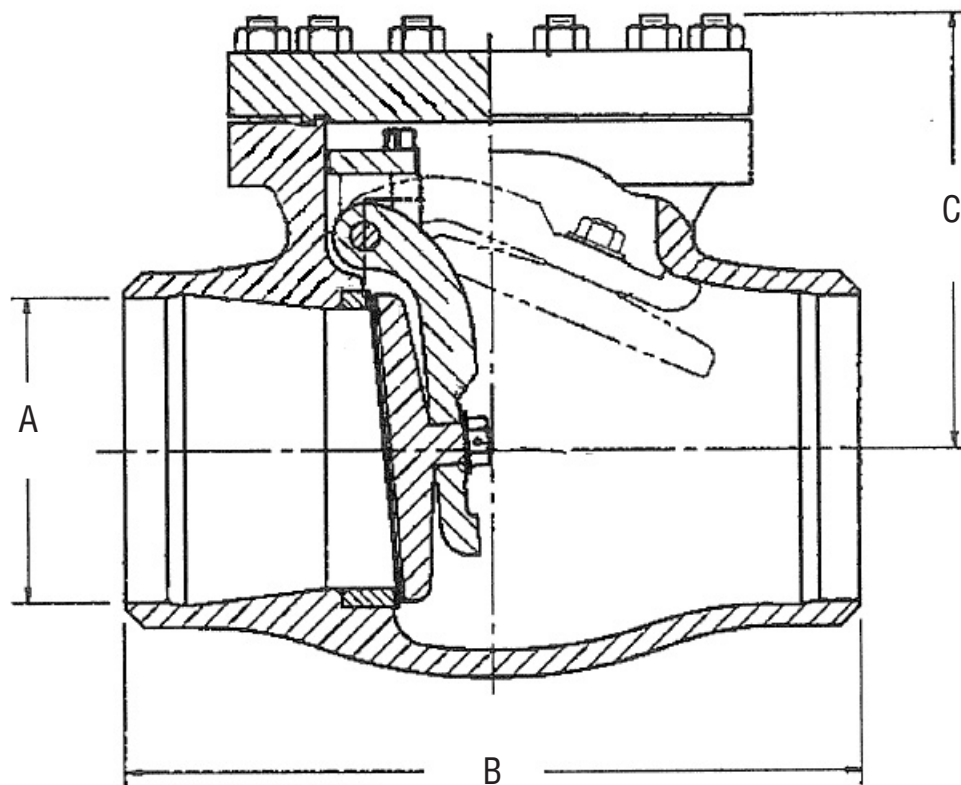

### Standard Features

- Carbon, stainless or special alloys
- Bolted bonnet
- Available Stellite seat and disc
- No body penetration
- Easily accessible hinge
- Extended hinge, preventing disc contact with body
- Inclined seat to ensure closure even in no-flow condition

### Pressure Class 150 (PN 25)

Fig. No.	Type	Ends	NPS (DN)
BSC52U	Swing Check	Butt Weld	2½ (65) thru 24 (600)
BSC52C	Swing Check	Flanged	2½ (65) thru 24 (600)

### Dimensions

Black numerals are in inches and pounds  
Colored numerals are in millimeters and kilograms

Figure No. BSC52U/BSC52C	NPS	2½	3	4	6	8	10	12	14	16	18	20	24
	DN	65	80	100	150	200	250	300	350	400	450	500	600
A		2.5	3	4	6	8	10	12	13.3	16.3	17.3	19.3	23.3
		64	76	102	152	203	254	305	338	389	439	490	592
B		8.5	9.5	11.5	14	19.5	12.5	27.5	31	34	38.5	38.5	44
		216	241	292	356	495	622	699	787	864	978	978	1,118
C		6	6	6.5	8.5	11	12.5	13.5	15	16	18	21.5	25
		152	152	165	216	279	318	343	381	406	457	546	635
Weight Approx (lbs.)		35	75	90	190	240	430	625	720	975	1,260	1,635	2,475
		15.8	34.0	40.8	86.2	108.9	195.0	283.5	326.6	442.3	571.5	741.6	1,122.7
Cv		175	275	525	1,225	2,225	3,600	5,250	6,500	8,750	11,375	14,425	21,400

Refer to page 141 for materials of construction.

Refer to pages 203 through 238 for the applicable pressure ratings.

## Swing-Check Valves, Class 300

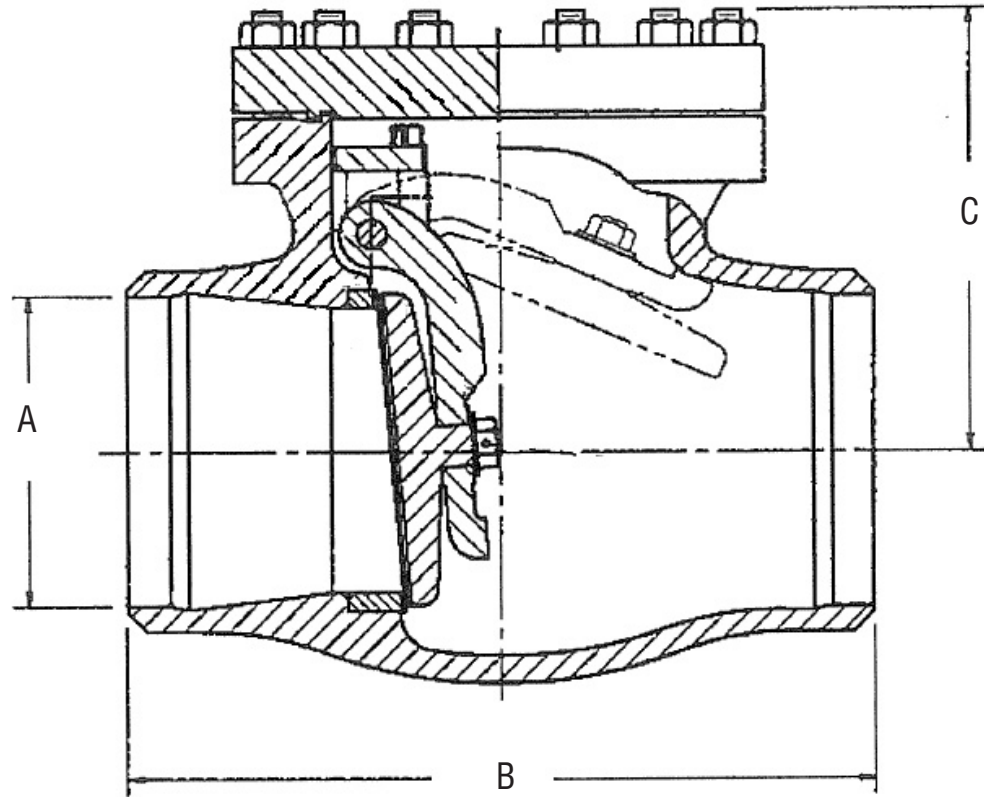

### Standard Features

- Carbon, stainless or special alloys
- Bolted bonnet
- Available Stellite seat and disc
- No body penetration
- Easily accessible hinge
- Extended hinge, preventing disc contact with body
- Inclined seat to ensure closure even in no-flow condition

### Pressure Class 300 (PN 50)

Fig. No.	Type	Ends	NPS (DN)
CSC51U	Swing Check	Butt Weld	2½ (65) thru 24 (600)
CSC51C	Swing Check	Flanged	2½ (65) thru 24 (600)

### Dimensions

Black numerals are in inches and pounds  
Colored numerals are in millimeters and kilograms

Figure No. CSC51U/CSC51C	NPS	2½	3	4	6	8	10	12	14	16	18	20	24
	DN	65	80	100	150	200	250	300	350	400	450	500	600
A		2.5	3	4	6	8	10	12	13.3	15.3	17	19	23
		64	76	102	152	203	254	305	338	389	439	490	584
B		11.5	12.5	14	17.5	21	24.5	28	33	34	38.5	40	44
		292	318	356	445	533	600	711	838	864	978	1,016	1,118
C		6	6.5	7.5	9.5	12	14.5	15.5	16.5	18	20	23.5	28
		152	168	191	241	305	368	394	419	457	508	597	711
Weight Approx (lbs.)		75	100	120	280	400	650	780	990	1,245	1,645	2,325	3,290
		34.0	45.4	54.4	127.0	181.4	294.8	353.8	449.1	564.7	746.2	1,054.6	1,492.3
Cv		175	275	525	1,225	2,225	3,600	5,250	6,500	8,750	11,050	14,050	20,950

Refer to page 141 for materials of construction.

Refer to pages 203 through 238 for the applicable pressure ratings.

## Swing-Check Valves, Class 600

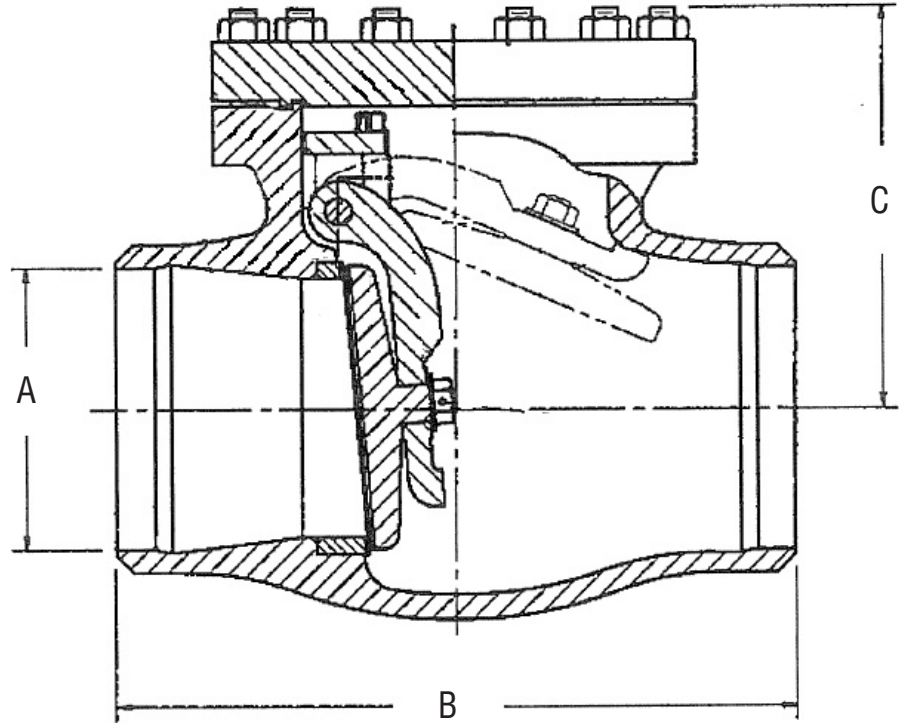

### Standard Features

- Carbon, stainless or special alloys
- Bolted bonnet or pressure seal
- Available Stellite seat and disc
- No body penetration
- Easily accessible hinge
- Extended hinge, preventing disc contact with body
- Inclined seat to ensure closure even in no-flow condition

### Pressure Class 600 (PN 110)

Fig. No.	Bonnet Type	Type	Ends	NPS (DN)
ESC51U	Bolted Bonnet	Swing Check	Butt Weld	2½ (65) thru 24 (600)
ESC51C	Bolted Bonnet	Swing Check	Flanged	2½ (65) thru 24 (600)
ESC58U	Pressure Seal	Swing Check	Butt Weld	2½ (65) thru 24 (600)
ESC58C	Pressure Seal	Swing Check	Flanged	2½ (65) thru 24 (600)

### Dimensions – Swing

Black numerals are in inches and pounds  
Colored numerals are in millimeters and kilograms

Figure No. ESC51U/ESC51C, ESC58U/ESC58C	NPS	2½	3	4	6	8	10	12	14	16	18	20	24
	DN	65	80	100	150	200	250	300	350	400	450	500	600
A		2.5	3	4	6	7.9	9.8	11.8	12.9	14.8	16.5	18.3	22
		64	76	102	127	200	248	298	327	375	470	464	559
B		8.5	10	12	18	23	28	32	35	39	43	47	55
		216	254	305	457	584	711	813	889	991	1,092	1,194	1,397
C		5	7	9	13	14	18	20	23	24	25	31	36
		127	178	229	330	356	457	508	584	610	635	787	914
Weight Approx (lbs.)		35	45	155	295	575	705	1,145	1,630	2,255	2,875	3,495	3,915
		15.9	20.4	70.3	133.8	260.8	319.8	519.4	739.4	1,023	1,304	1,585	1,776
Cv		175	275	500	1,200	2,125	3,375	5,000	6,100	8,125	10,325	12,850	19,000

Refer to page 141 for materials of construction.

Refer to pages 203 through 238 for the applicable pressure ratings.

## Swing-Check Valves, Class 900

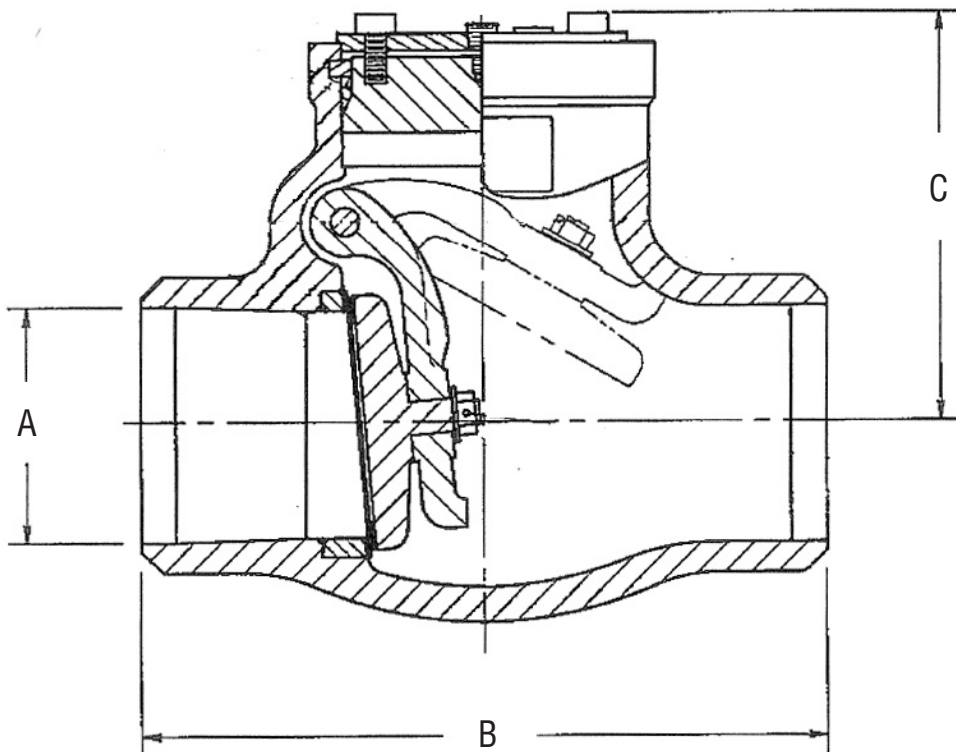

### Standard Features

- Carbon, stainless or special alloys
- Pressure seal
- Available Stellite seat and disc
- No body penetration
- Easily accessible hinge
- Extended hinge, preventing disc contact with body
- Inclined seat to ensure closure even in no-flow condition

### Pressure Class 900 (PN 150)

Fig. No.	Type	Ends	NPS (DN)
FSC58U	Swing Check	Butt Weld	2½ (65) thru 24 (600)
FSC58C	Swing Check	Flanged	2½ (65) thru 24 (600)

### Dimensions – Swing

Black numerals are in inches and pounds  
Colored numerals are in millimeters and kilograms

Figure No. FSC58U/ FSC58C	NPS	2½	3	4	6	8	10	12	14	16	18	20	24
	DN	65	80	100	150	200	250	300	350	400	450	500	600
A		2.3	2.9	3.9	5.8	7.5	9.4	11.1	12.3	14	15.8	17.5	21
		57	73	99	146	191	238	282	311	356	400	445	533
B		10	12	14	20	26	31	36	39	43	46	50	59
		254	305	356	508	660	787	914	991	1,092	1,168	1,270	1,499
C		6.5	6.5	9.5	12	13.5	15	18	20	22	24	25	29
		165	165	241	305	343	381	457	508	559	610	635	737
Weight Approx (lbs.)		50	65	145	375	600	860	1,670	1,985	2,415	3,145	4,105	6,380
		22.7	29.5	65.8	170.1	272.1	385.6	757.5	900.4	1,095	1,427	1,862	2,894
Cv		150	250	475	1,100	1,925	3,100	4,475	5,525	7,325	9,425	11,825	17,300

Refer to page 141 for materials of construction.

Refer to pages 203 through 238 for the applicable pressure ratings.

## Swing-Check Valves, Class 1500

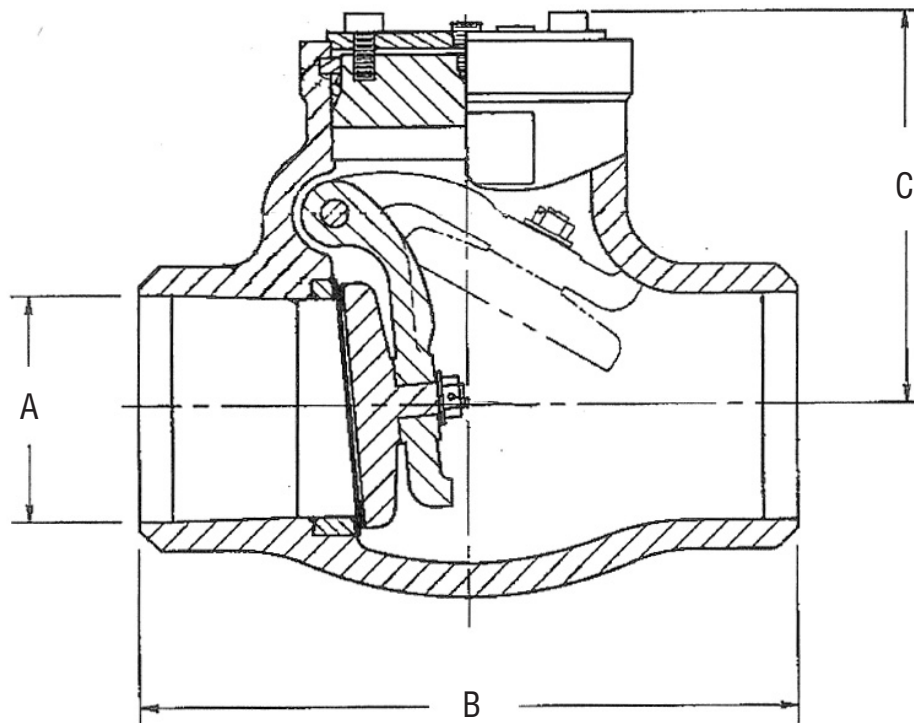

### Standard Features

- Carbon, stainless or special alloys
- Bolted bonnet or pressure seal
- Available Stellite seat and disc
- No body penetration
- Easily accessible hinge
- Extended hinge, preventing disc contact with body
- Inclined seat to ensure closure even in no-flow condition

### Pressure Class 1500 (PN 260)

Fig. No.	Type	Ends	NPS (DN)
GSC58U	Swing Check	Butt Weld	2½ (65) thru 24 (600)
GSC58C	Swing Check	Flanged	2½ (65) thru 24 (600)

### Dimensions – Swing

Black numerals are in inches and pounds  
Colored numerals are in millimeters and kilograms

Figure No. GSC58U/GSC58C	NPS	2½	3	4	6	8	10	12	14	16	18	20	24
	DN	65	80	100	150	200	250	300	350	400	450	500	600
A		2.3	2.8	3.6	5.4	7	8.8	10.4	11.4	13	14.6	16.4	19.6
		57	70	92	137	178	222	264	289	330	371	416	498
B		10	12	16	22	28	34	39	42	47	53	58	68
		254	305	406	559	711	864	991	1,067	1,194	1,346	1,473	1,727
C		8.5	9	10	12	18	22	26	30	36	42	47	57
		165	229	254	305	457	559	711	762	914	1,067	1,194	1,448
Weight Approx (lbs.)		50	75	160	570	1,085	1,415	2,175	2,960	3,985	4,715	7,665	8,380
		22.7	34.0	68.0	258.6	492.2	641.8	986.6	1,343	1,808	2,139	3,431	3,801
Cv		150	225	400	950	1,675	2,675	3,825	4,650	6,175	7,925	10,025	14,725

Refer to page 141 for materials of construction.

Refer to pages 203 through 238 for the applicable pressure ratings.



## Anchor/Darling Ball Valves



## Features and Description of Flowserve Anchor/Darling Ball Valves

### Applications

Anchor/Darling ball valves are designed and engineered to provide dependable service in demanding nuclear applications, where high performance and low maintenance costs are a necessity. Typical applications include:

- Sampling Systems (gaseous & liquid)
- Rad-Waste Cleanup Systems
- Component Cooling Systems
- Chemical Make-up Systems
- Service Water Systems
- Instrument Air Service
- Containment Sump
- Vents & Drains
- Air Lock Systems

### Valve Options

Unmatched flexibility and cost efficiency are derived from the wide selection of three-piece and top-entry valves and the variety of selectable options. These options encompass:

- Valve Types & Sizes
- Port Configurations
- Seating Materials

- Valve Body Materials
- Ball Materials
- Pressure Classes
- Valve Operators
- Accessories

### Features

Anchor/Darling ball valves offer several inherent features in their design that are unmatched by conventional gate and globe valves. These ball valves provide:

- Lower pressure drop due to straight-through flow paths
- Fewer internal crevices reducing the potential for “crud” traps
- Easier and “less costly” repairs—no required cutting or disrupting of pipes is required
- Lower radiation exposure to personnel due to quick removal of all valve internals
- Lower center of gravity minimizing seismic loads

Flowserve Anchor/Darling ball valves also feature pressure-seated, blow-out-proof stems, which utilize line pressure to ensure maximum sealing action.

**Flowserve can supply custom-engineered safety-related and non-safety-related ball valves to meet your specifications and requirements.**

## Parts Specification List for Anchor/Darling Ball Valves

### Standard Features

- Available body material  
SA696-C  
SA479-316
- Full or standard port
- Bi-directional sealing

Parts shown are not applicable to all Ball Valves. Construction and materials for nuclear valves vary depending on customer design specifications. For a complete, accurate and itemized description of a particular valve, contact your local Flowserve valves sales representative.

### Seat & Seal Material Selection Chart

Set	Seats	Stem O-Ring	Body O-Rings	Stem Seals
A	UHMWPE	EPR	EPR	UHMWPE
B	EPDM	EPR	EPR	UHMWPE
C	Teflon	EPR	EPR	RPTFE
D	Viton	Viton	Viton	UHMWPE

### Materials

Description	Typical Carbon Steel		Typical Stainless Steel	
	Material	Material Spec. ASME-SA ASTM-A	Material	Material Spec. ASME-SA ASTM-A
Body	Carbon Steel	SA 696-C with Phosphate	Stainless Steel	SA479-316
Ball	Stainless Steel	SA479-316	Stainless Steel	SA479-316
Seats	See Chart		See Chart	
Stem	Stainless Steel	A564-630-1075	Stainless Steel	A564-630-1075
End Pieces	Carbon Steel	SA696-C with Phosphate	Stainless Steel	SA479-316
Gland Ring	Stainless Steel	AISI 300	Stainless Steel	AISI 300
Handle	Carbon Steel	AISI 1010*	Carbon Steel	AISI 1010*
Hex Nuts	Carbon Steel	SA194-2H with Phosphate	Carbon Steel	SA194-2H with Phosphate
Lockwashers	Stainless Steel	AISI 300	Stainless Steel	AISI 300
Hex Capscrews	Alloy Steel	SA193-87 with Phosphate	Alloy Steel	SA193-87 with Phosphate
O-Rings (Body)	See Chart		See Chart	
O-Rings (Stem)	See Chart		See Chart	
Stem Seals	See Chart		See Chart	
Locknut (Stem)	Stainless Steel	AISI 300	Stainless Steel	AISI 300

\*Denotes with zinc and plastisol coatings

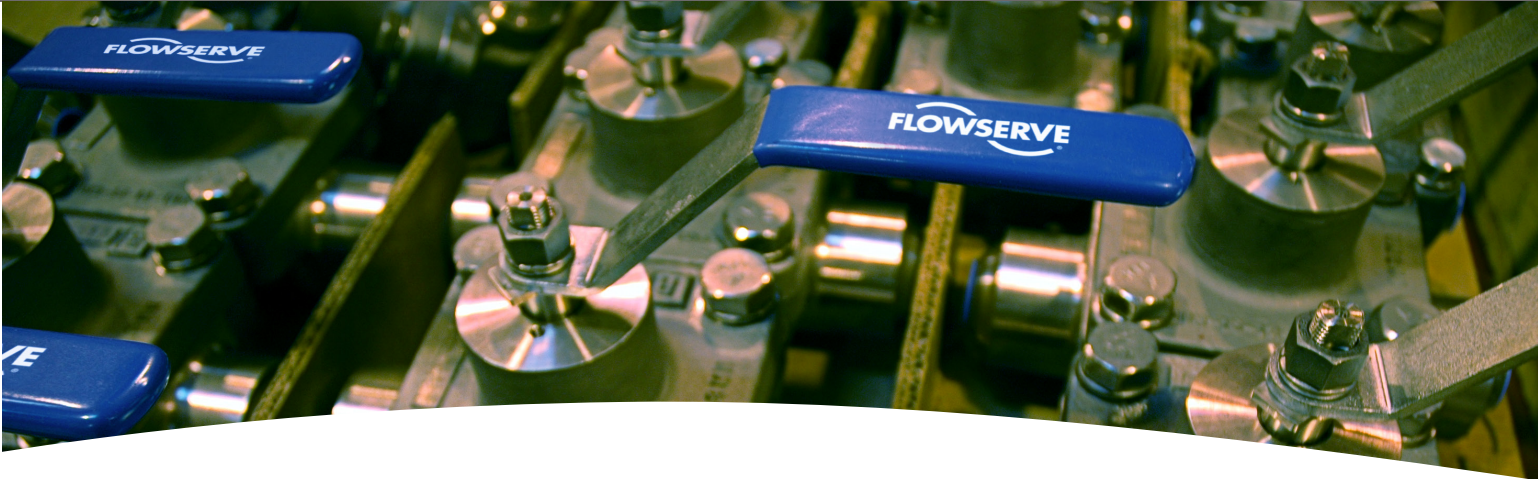

## E-Series/C-Series/Top-Entry Ball Valve Data

### Standard Seating Materials

Temperature/radiation limits are based upon actual seating material qualification testing and/or manufacturer's recommendations:

Seat Material	Max. Temperature (continuous)	Radiation Limit (5-year exposure)
Teflon	300°F	2 x 10 <sup>4</sup> Rads
Reinforced Teflon	350°F	5 x 10 <sup>5</sup> Rads
UHMWPE	200°F	8 x 10 <sup>7</sup> Rads
Tefzel	300°F	9 x 10 <sup>7</sup> Rads
Viton	400°F	5 x 10 <sup>7</sup> Rads
EPDM	400°F	5 x 10 <sup>7</sup> Rads

Optional seating materials are available for severe service applications; contact Flowserve for application assistance. Higher temperature excursions are permissible; consult factory for limitations.

### Valve Operators

Flowserve has a complete line of valve operators available for use with Anchor/Darling ball valves.

### Flow Coefficients (C<sub>v</sub>)

Valve Size	Standard Port	Full Port
½"	N/A	16.5
¾"	16.5	27
1"	27	50
1¼"	50	78
1½"	78	120
2"	120	195
2½"	195	240
3"	240	700
4"	700	1400
6"	1400	N/A

*Note: Values based on flow of water in gallons per minute (GPM) at standard conditions to achieve a one (1) PSI pressure drop.*

Other valve operators can be specified and supplied to suit customer requirements. Additionally, valves can be configured to mate with many existing valve operators (if appropriately sized) and accessory items (i.e., position indicating and limit switches).

## Top-Entry Ball Valves, Class 150

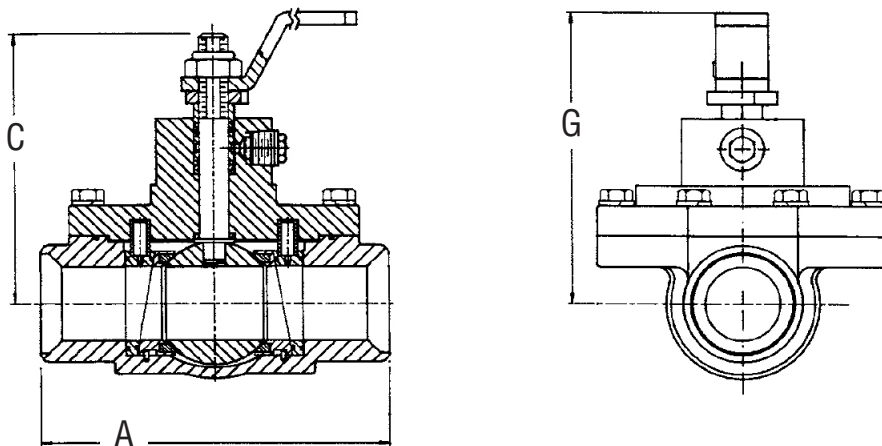

### Pressure Class 150 (PN 25)

Fig. No.	Type	Ends	NPS (DN)
BBV96U	Ball	Butt Weld	1 (25) thru 6 (150)

### Dimensions

Black numerals are in inches and pounds  
Colored numerals are in millimeters and kilograms

Figure No. BBV96U, Standard Port	NPS	1	1¼	1½	2	2½	3	4	6
	DN	25	32	40	50	65	80	100	150
A		5.3	8.5	7.5	9.5	11.5	11.1	14	22
		135	216	191	241	292	282	356	559
C		4.8	5.2	5.9	6.1	7.8	8	10.1	11.9
		122	132	150	155	198	203	257	302
G		5.9	6.3	7.4	7.6	9.1	9.4	11.4	
		127	160	188	193	231	239	290	

### Pressure Class 150 (PN 25)

Fig. No.	Type	Ends	NPS (DN)
BBV93U	Ball	Butt Weld	1 (25) thru 4 (100)

### Dimensions

Black numerals are in inches and pounds  
Colored numerals are in millimeters and kilograms

Figure No. BBV93U, Full Port	NPS	1	1¼	1½	2	2½	3	4
	DN	25	32	40	50	65	80	100
A		8.5	7.5	9.5	11.5	11.1	14	22
		216	191	241	292	282	356	559
C		5.2	5.9	6.1	7.8	8	10.1	11.9
		132	150	155	198	203	257	302
G		6.3	7.4	7.6	9.1	9.4	11.4	
		160	188	193	231	239	290	

Valve weights for top-entry valves are not published due to the customized nature of this product and the associated variables, which can affect total weight. After receiving customer's requirements for valve size, materials, valve operator requirements, etc., Anchor/Darling can furnish assembly weights. Consult factory for certified weights.

Refer to page 155 for materials of construction.

Refer to pages 203 through 238 for the applicable pressure ratings.

## Top-Entry Ball Valves, Class 300

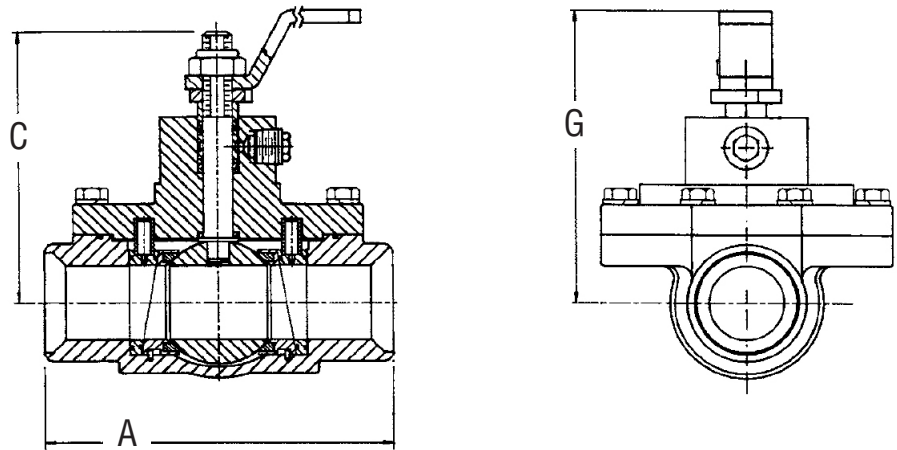

### Pressure Class 300 (PN 50)

Fig. No.	Type	Ends	NPS (DN)
CBV96U	Ball	Butt Weld	1 (25) thru 6 (150)

Black numerals are in inches and pounds  
Colored numerals are in millimeters and kilograms

### Dimensions

Figure No. CBV96U, Standard Port	NPS	1	1¼	1½	2	2½	3	4	6
	DN	25	32	40	50	65	80	100	150
A		5.3	8.5	7.5	9.5	11.5	11.1	14	22
		135	216	191	241	292	282	356	559
C		4.8	5.2	5.9	6.1	7.8	8	10.1	11.9
		122	132	150	155	198	203	257	302
G		5.9	6.3	7.4	7.6	9.1	9.4	11.4	
		127	160	188	193	231	239	290	

### Pressure Class 300 (PN 50)

Fig. No.	Type	Ends	NPS (DN)
CBV93U	Ball	Butt Weld	1 (25) thru 4 (100)

Black numerals are in inches and pounds  
Colored numerals are in millimeters and kilograms

### Dimensions

Figure No. CBV93U, Full Port	NPS	1	1¼	1½	2	2½	3	4
	DN	25	32	40	50	65	80	100
A		8.5	7.5	9.5	11.5	11.1	14	22
		216	191	241	292	282	356	559
C		5.2	5.9	6.1	7.8	8	10.1	11.9
		132	150	155	198	203	257	302
G		6.3	7.4	7.6	9.1	9.4	11.4	
		160	188	193	231	239	290	

Valve weights for top-entry valves are not published due to the customized nature of this product and the associated variables, which can affect total weight. After receiving customer's requirements for valve size, materials, valve operator requirements, etc., Anchor/Darling can furnish assembly weights. Consult factory for certified weights.

Refer to page 155 for materials of construction.

Refer to pages 203 through 238 for the applicable pressure ratings.

## E-Series Ball Valves Standard Port, Class 150

Carbon or stainless steel ball valve with lever actuator

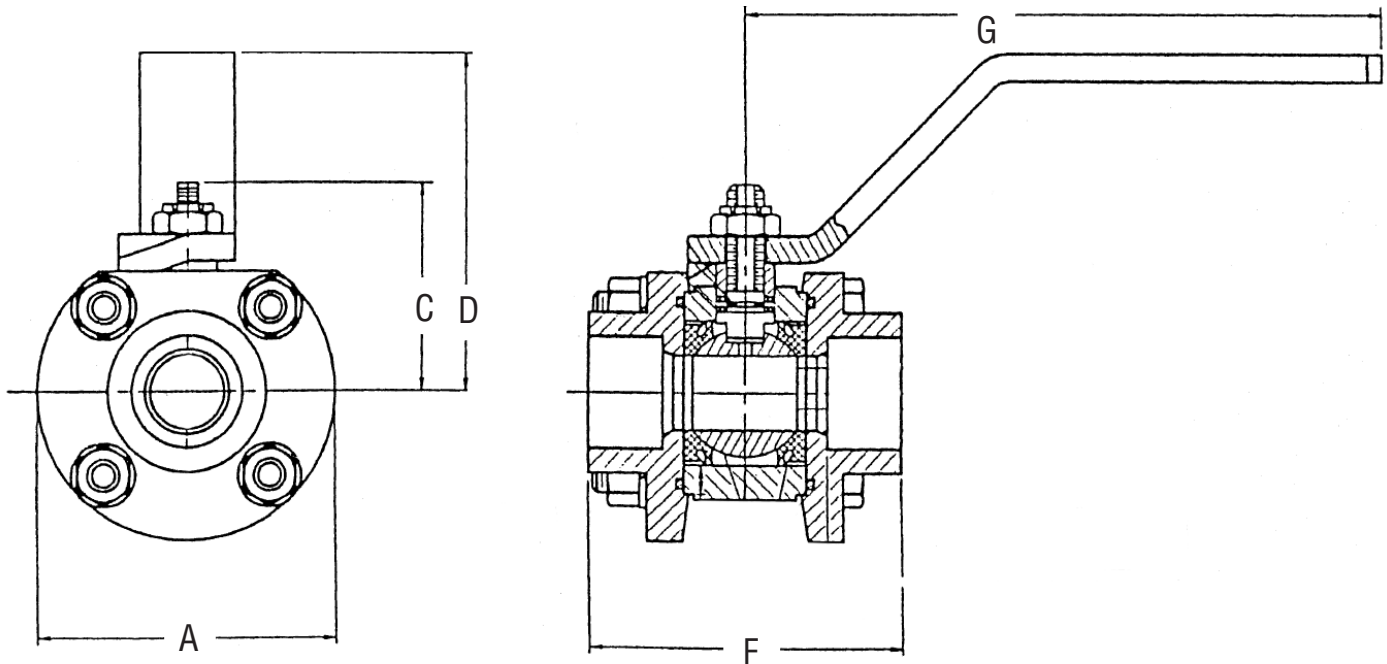

### Notes

Drawing has typical information only.

For installation purposes, use certified drawing.

### Pressure Class 150 (PN 25)

Fig. No.	Type	Ends	NPS (DN)
BBV94S	Ball	Socket Weld	¾ (20) thru 2 (50)

### Dimensions

Black numerals are in inches and pounds  
Colored numerals are in millimeters and kilograms

Figure No. BBV94S	NPS	¾	1	1¼	1½	2
	DN	20	25	32	40	50
A		2.8	3.3	3.8	4.3	5
		71	84	95	108	127
C		1.6	2.1	2.4	2.6	2.9
		41	53	61	66	74
D		2.5	3.3	4	4.3	4.6
		64	84	102	109	117
F		2.6	3.1	3.6	4	4.6
		66	79	91	102	117
G		6	6	7	7	9
		152	152	178	178	229
Weight Approx (lbs.)		2.9	4.7	7.3	10.4	15.8
		1.3	2.1	3.3	4.7	7.2
Cv		16.5	27	50	78	120

Refer to page 155 for materials of construction.

Refer to pages 203 through 238 for the applicable pressure ratings.

## E-Series Ball Valves, Standard Port, Class 150

Carbon or stainless steel ball valve with lever actuator

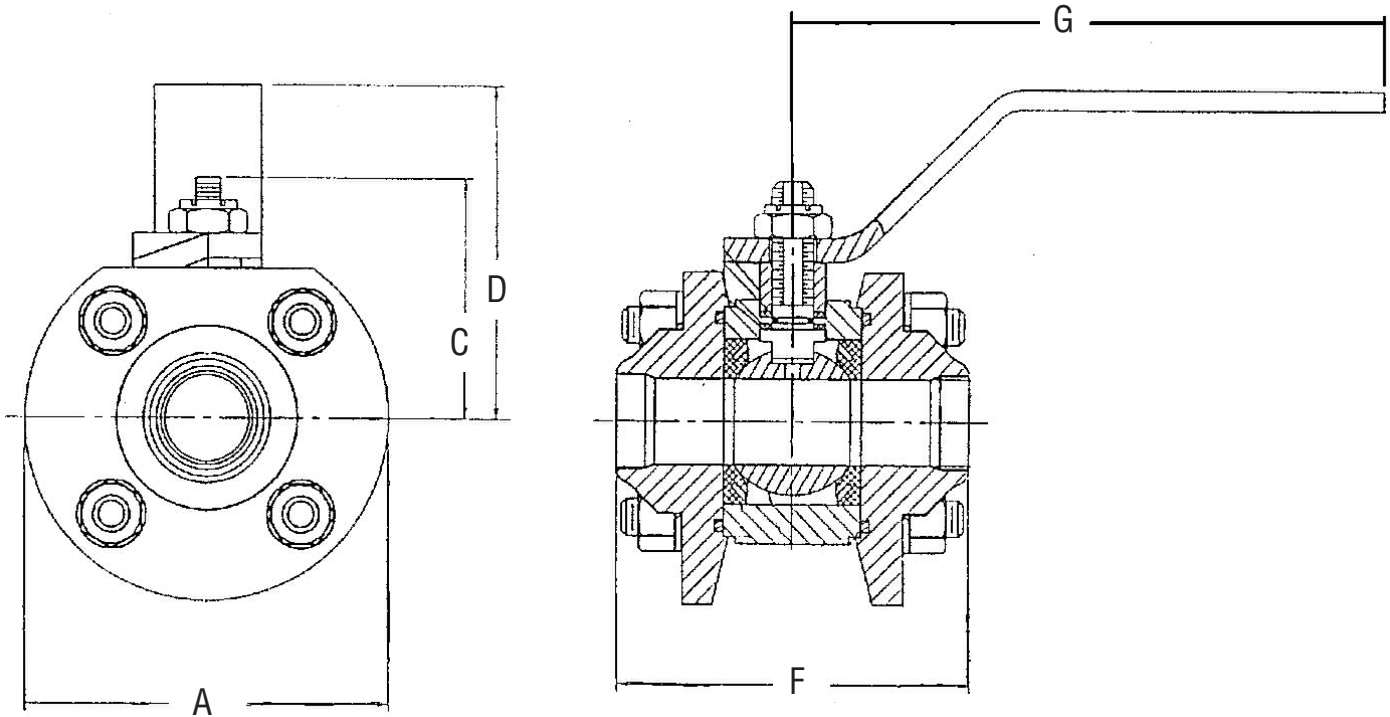

### Notes

Drawing has typical information only.

For installation purposes, use certified drawing.

### Pressure Class 150 (PN 25)

Fig. No.	Type	Ends	NPS (DN)
BBV94U	Ball	Butt Weld	2½ (20) thru 6 (50)

### Dimensions

Black numerals are in inches and pounds  
Colored numerals are in millimeters and kilograms

Figure No. BBV94U	NPS	2½	3	4	6
	DN	65	80	100	150
A		5.5	6.8	8.3	10.5
		140	173	211	267
C		3.3	3.6	5.3	7.3
		84	91	135	185
D		4.9	5.8	7.1	9.1
		124	147	180	231
F		6.0	6.8	8.1	10.1
		152	173	206	257
G		9.0	12.0	16.0	28.0
		229	305	406	711
Weight Approx (lbs.)		18	30	56	120
		8.2	13.6	25.4	54.4
Cv		195	240	700	1400

Refer to page 155 for materials of construction.

Refer to pages 203 through 238 for the applicable pressure ratings.



## E-Series Ball Valves, Standard Port, Class 150

Carbon or stainless steel ball valve with lever actuator

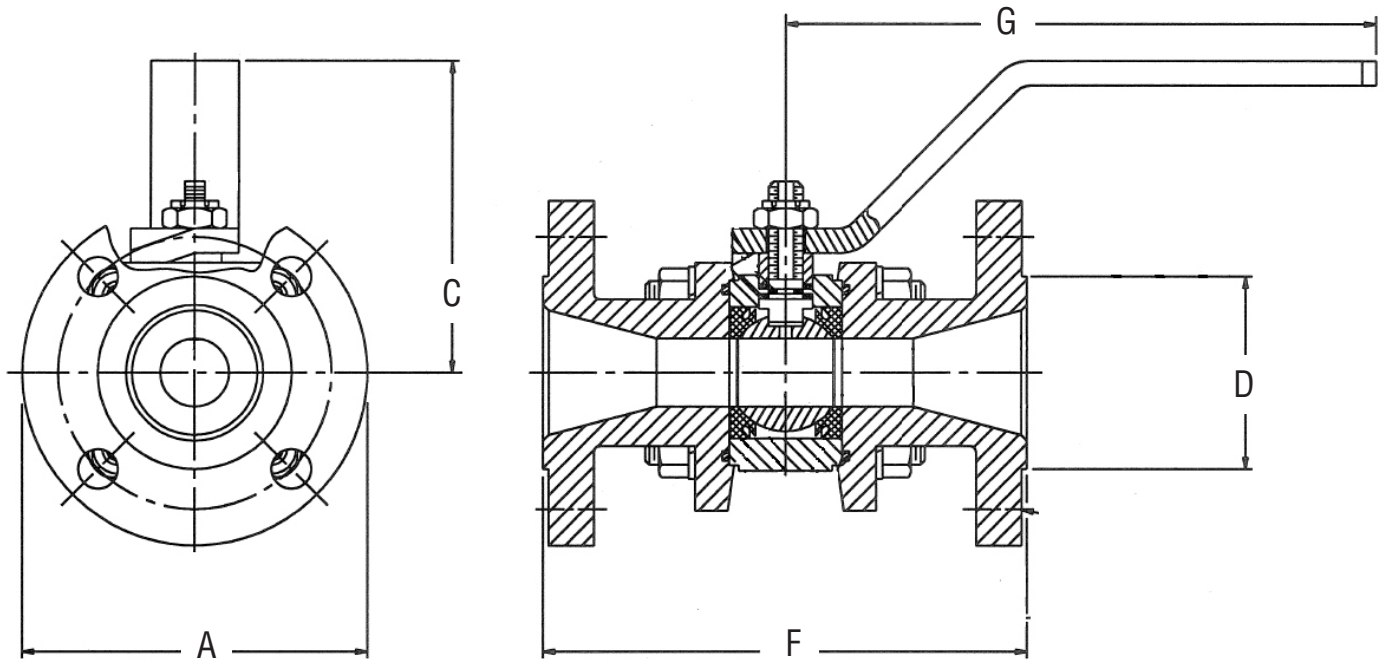

### Notes

Drawing has typical information only.

For installation purposes, use certified drawing.

### Pressure Class 150 (PN 25)

Fig. No.	Type	Ends	NPS (DN)
BBV94C	Ball	Flanged	2½ (65) thru 6 (150)

### Dimensions

Black numerals are in inches and pounds  
Colored numerals are in millimeters and kilograms

Figure No. BBV94C	NPS	2½	3	4	6
	DN	65	80	100	150
A		5.5	6.8	8.3	10.5
		140	173	211	267
C		3.3	3.6	5.3	7.3
		84	91	135	185
D		4.9	5.8	7.1	9.1
		124	147	180	231
F		10.3	10.3	12	14.3
		262	262	305	363
G		9.0	12.0	16.0	28
		229	305	406	711
Weight Approx (lbs.)		38	54	92	181
		17.2	24.5	41.7	82.1
Cv		195	240	700	1400

Refer to page 155 for materials of construction.

Refer to pages 203 through 238 for the applicable pressure ratings.

## E-Series Ball Valves Full Port, Class 150

Carbon or stainless steel ball valve with lever actuator

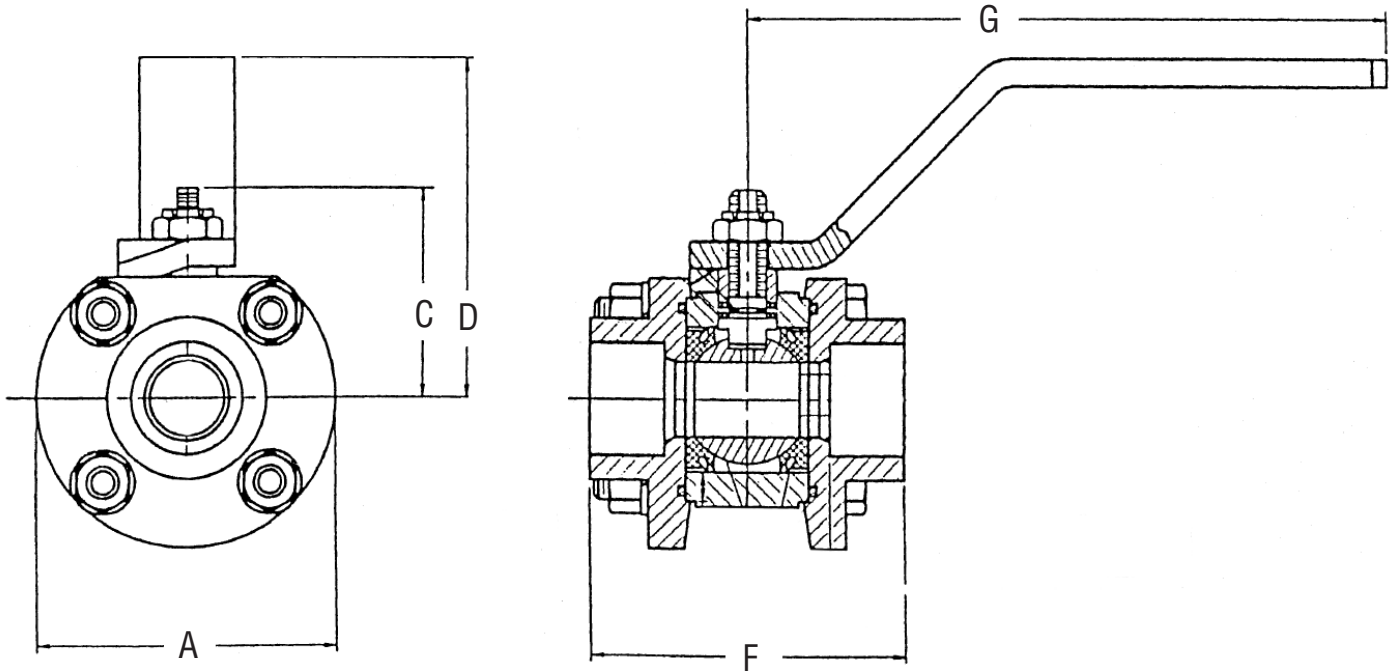

### Notes

Drawing has typical information only.

For installation purposes, use certified drawing.

### Pressure Class 150 (PN 25)

Fig. No.	Type	Ends	NPS (DN)
BBV95S	Ball	Socket Weld	½ (15) thru 2 (50)

### Dimensions

Black numerals are in inches and pounds  
Colored numerals are in millimeters and kilograms

Figure No. BBV95S	NPS	½	¾	1	1¼	1½	2
	DN	15	20	25	32	40	50
A		2.8	3.3	3.8	4.3	5.0	6.3
		71	84	97	109	127	160
C		1.6	2.1	2.4	2.6	2.9	3.3
		41	53	61	66	74	84
D		2.5	3.3	4	4.3	4.6	5
		64	84	102	109	117	127
F		2.6	3.1	3.6	4	4.6	6
		66	79	91	102	117	152
G		6	6	7	7	9	9
		152	152	178	178	229	229
Weight Approx		2.9	4.7	7.3	10.4	15.8	23.8
		1.3	2.1	3.3	4.7	7.2	10.8
Cv		16.5	27	50	78	120	195

Refer to page 155 for materials of construction.

Refer to pages 203 through 238 for the applicable pressure ratings.

## E-Series Ball Valves, Full Port, Class 150

Carbon or stainless steel ball valve with lever actuator

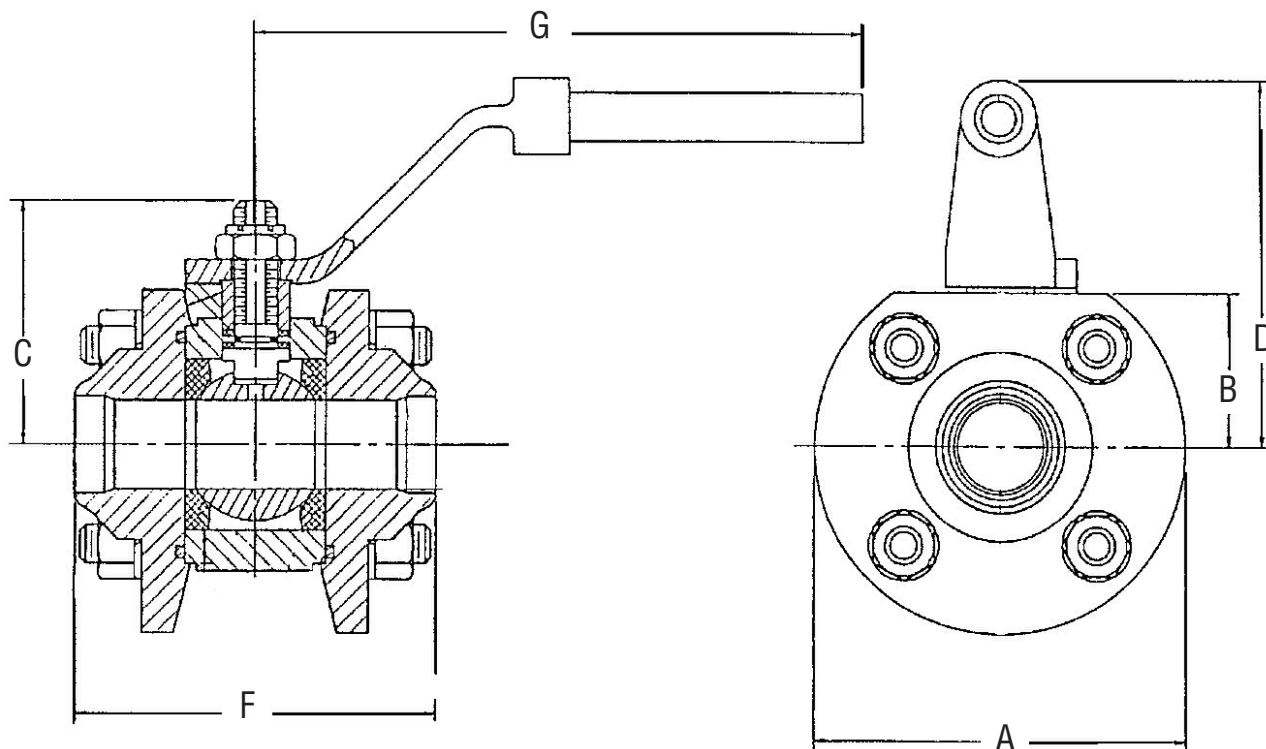

### Notes

Drawing has typical information only.  
For installation purposes, use certified drawing.

### Pressure Class 150 (PN 25)

Fig. No.	Type	Ends	NPS (DN)
BBV95U	Ball	Butt Weld	3 (80) and 4 (100)

### Dimensions

Black numerals are in inches and pounds  
Colored numerals are in millimeters and kilograms

Figure No. BBV95U	NPS	3	4
	DN	80	100
A		8.3	10.5
		211	267
B		3.5	
		89	
C		5.3	7.3
		135	185
D		7.1	9.3
		180	236
F		8.1	10.1
		206	257
G		16.0	28.0
		406	711
Weight Approx (lbs.)		57	120
		25.9	54.4
Cv		700	1400

Refer to page 155 for materials of construction.  
Refer to pages 203 through 238 for the applicable pressure ratings.

## E-Series Ball Valves, Full Port, Class 150

Carbon or stainless steel ball valve with lever actuator

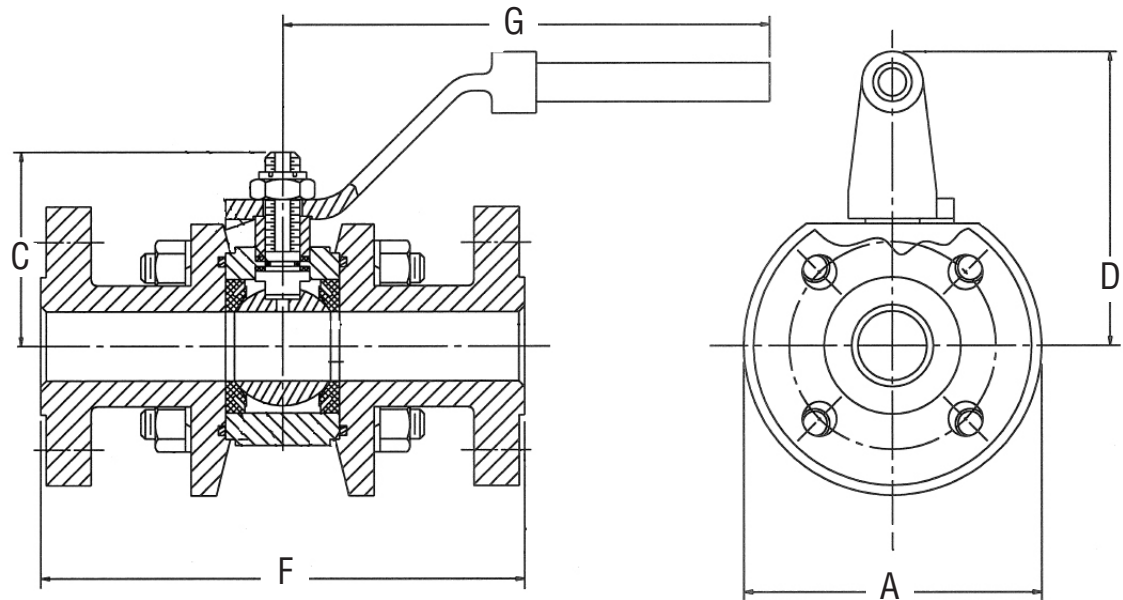

### Notes

Drawing has typical information only.

For installation purposes, use certified drawing.

### Pressure Class 150 (PN 25)

Fig. No.	Type	Ends	NPS (DN)
BBV95C	Ball	Flanged	3 (80) and 4 (100)

### Dimensions

Figure No. BBV95C	NPS	3	4
	DN	80	100
A		8.3	10.5
		211	267
C		5.3	7.3
		135	185
D		7.1	9.3
		180	236
F		12	14.3
		305	363
G		16	28
		406	711
Weight Approx (lbs.)		80	153
		36.3	69.4
Cv		700	1400

Refer to page 155 for materials of construction.

Refer to pages 203 through 238 for the applicable pressure ratings.

## E-Series Ball Valves Standard Port, Class 300

Carbon or stainless steel ball valve with lever actuator

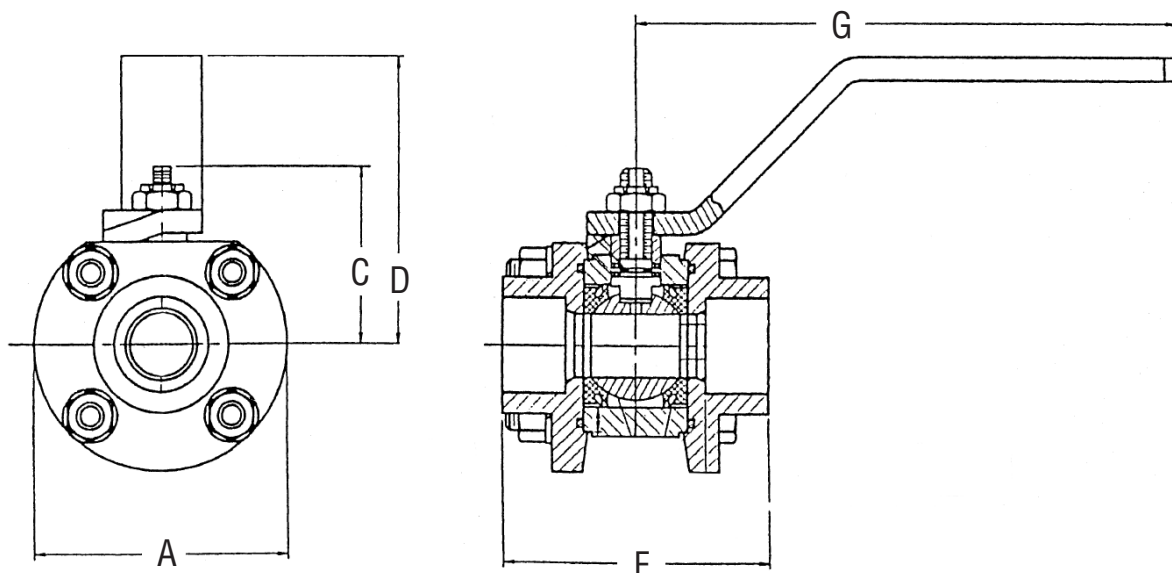

### Notes

Drawing has typical information only.

For installation purposes, use certified drawing.

### Pressure Class 300 (PN 50)

Fig. No.	Type	Ends	NPS (DN)
CBV94S	Ball	Socket Weld	¾ (20) thru 2 (50)

### Dimensions

Black numerals are in inches and pounds  
Colored numerals are in millimeters and kilograms

Figure No. CBV94S	NPS	¾	1	1¼	1½	2
	DN	20	25	32	40	50
A		2.8	3.3	3.8	4.3	5
		71	84	95	108	127
C		1.6	2.1	2.4	2.6	2.9
		41	53	61	66	74
D		2.5	3.3	4	4.3	4.6
		64	84	102	109	117
F		2.6	3.1	3.6	4	4.6
		66	79	91	102	117
G		6	6	7	7	9
		152	152	178	178	229
Weight Approx (lbs.)		2.9	4.7	7.3	10.4	15.8
		1.3	2.1	3.3	4.7	7.2
Cv		16.5	27	50	78	120

Refer to page 155 for materials of construction.

Refer to pages 203 through 238 for the applicable pressure ratings.

## E-Series Ball Valves, Standard Port, Class 300

Carbon or stainless steel ball valve with lever actuator

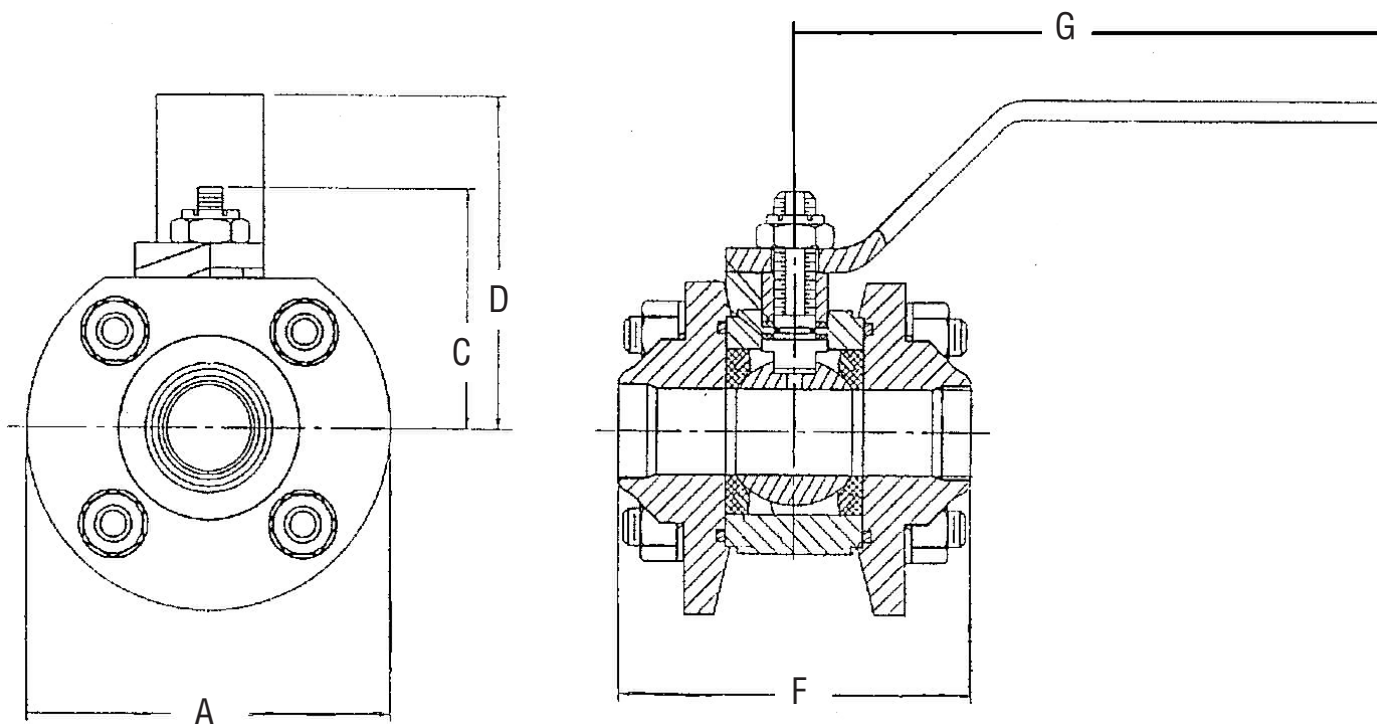

### Notes

Drawing has typical information only.

For installation purposes, use certified drawing.

### Pressure Class 300 (PN 50)

Fig. No.	Type	Ends	NPS (DN)
CBV94U	Ball	Butt Weld	3 (20) thru 4 (50)

### Dimensions

Black numerals are in inches and pounds  
Colored numerals are in millimeters and kilograms

Figure No. CBV94U	NPS	2½	3	4	6
	DN	65	80	100	150
A		5.5 140	6.8 173	8.3 211	10.5 267
C		3.3 84	3.6 91	5.3 135	7.3 185
D		4.9 124	5.8 147	7.1 180	9.1 231
F		6.0 152	6.8 173	8.1 206	10.1 257
G		9.0 229	12.0 305	16.0 406	28.0 711
Weight Approx (lbs.)		18 8.2	30 13.6	56 25.4	120 54.4
Cv		195	240	700	1400

Refer to page 155 for materials of construction.

Refer to pages 203 through 238 for the applicable pressure ratings.

## E-Series Ball Valve, Standard Port, Class 300

Carbon or stainless steel ball valve with lever actuator

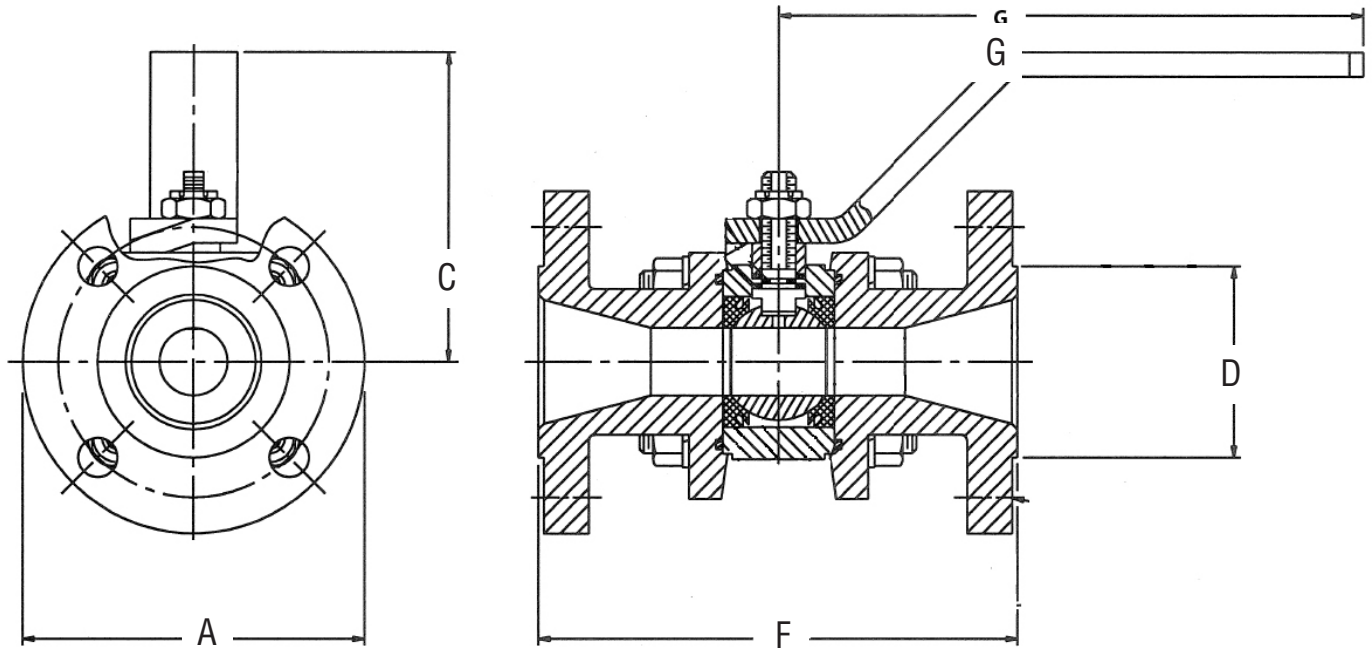

### Notes

Drawing has typical information only.

For installation purposes, use certified drawing.

### Pressure Class 300 (PN 50)

Fig. No.	Type	Ends	NPS (DN)
CBV94C	Ball	Flanged	2½ (65) thru 6 (150)

### Dimensions

Black numerals are in inches and pounds  
Colored numerals are in millimeters and kilograms

Figure No. CBV94C	NPS	2½	3	4	6
	DN	65	80	100	150
A		5.5	6.8	8.3	10.5
		140	173	211	267
C		3.3	3.6	5.3	7.3
		84	91	135	185
D		4.9	5.8	7.1	9.1
		124	147	180	231
F		10.5	11	13	15.5
		267	279	330	394
G		9.0	12.0	16.0	28.0
		229	305	406	711
Weight Approx (lbs.)		42	63	112	221
		19.1	28.6	50.8	100.2
Cv		195	240	700	1400

Refer to page 155 for materials of construction.

Refer to pages 203 through 238 for the applicable pressure ratings.

## E-Series Ball Valves Full Port, Class 300

Carbon or stainless steel ball valve with lever actuator

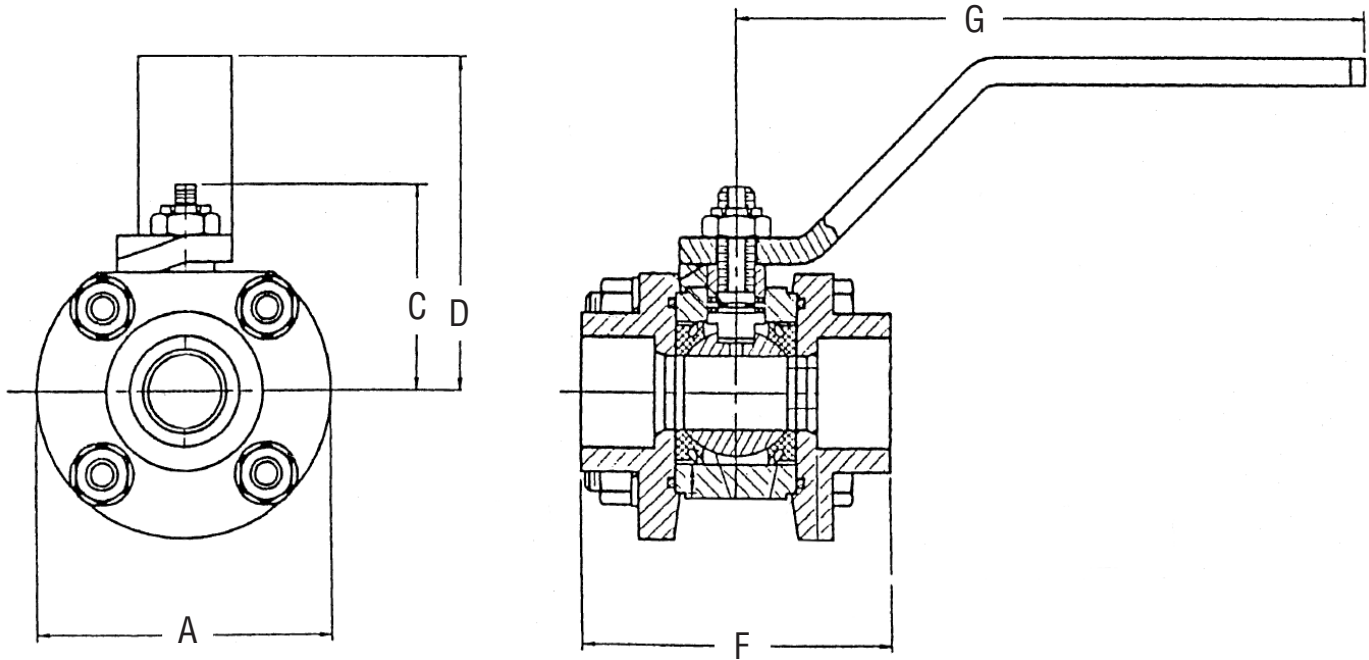

### Notes

Drawing has typical information only.

For installation purposes, use certified drawing.

### Pressure Class 300 (PN 50)

Fig. No.	Type	Ends	NPS (DN)
CBV95S	Ball	Socket Weld	1 (15) thru 2 (50)

### Dimensions

Black numerals are in inches and pounds  
Colored numerals are in millimeters and kilograms

Figure No. CBV95S	NPS	1/2	3/4	1	1 1/4	1 1/2	2
	DN	15	20	25	32	40	50
A		2.8	3.3	3.8	4.3	5.0	6.3
		71	84	97	109	127	160
C		1.6	2.1	2.4	2.6	2.9	3.4
		41	53	61	66	74	84
D		2.5	3.4	4	4.3	4.6	5
		64	84	102	109	117	127
F		2.6	3.1	3.6	4	4.6	6
		66	79	91	102	117	152
G		6	6	7	7	9	9
		152	152	178	178	229	229
Weight Approx (lbs.)		2.9	4.7	7.3	10.4	15.8	23.8
		1.3	2.1	3.3	4.7	7.2	10.8
Cv		16.5	27	50	78	120	195

Refer to page 155 for materials of construction.

Refer to pages 203 through 238 for the applicable pressure ratings.



## E-Series Ball Valves, Full Port, Class 300

Carbon or stainless steel ball valve with lever actuator

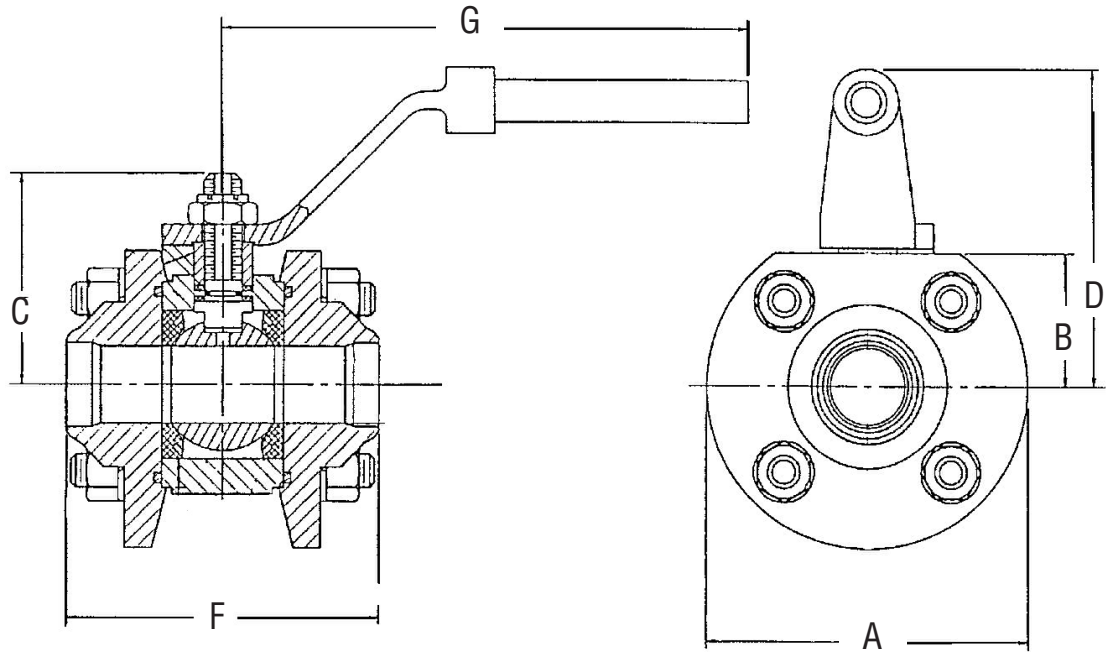

### Notes

Drawing has typical information only.

For installation purposes, use certified drawing.

### Pressure Class 300 (PN 50)

Fig. No.	Type	Ends	NPS (DN)
CBV95U	Ball	Butt Weld	3 (80) and 4 (100)

### Dimensions

Black numerals are in inches and pounds  
Colored numerals are in millimeters and kilograms

Figure No. CBV95U	NPS	3	4
	DN	80	100
A		8.3	10.5
		211	267
B		3.5	
		89	
C		5.3	7.3
		135	185
D		7.1	9.3
		180	236
F		8.1	10.1
		206	257
G		16.0	28
		406	711
Weight Approx (lbs.)		57	120
		25.9	54.4
Cv		700	1400

Refer to page 155 for materials of construction.

Refer to pages 203 through 238 for the applicable pressure ratings.

## E-Series Ball Valves, Full Port, Class 300

Carbon or stainless steel ball valve with lever actuator

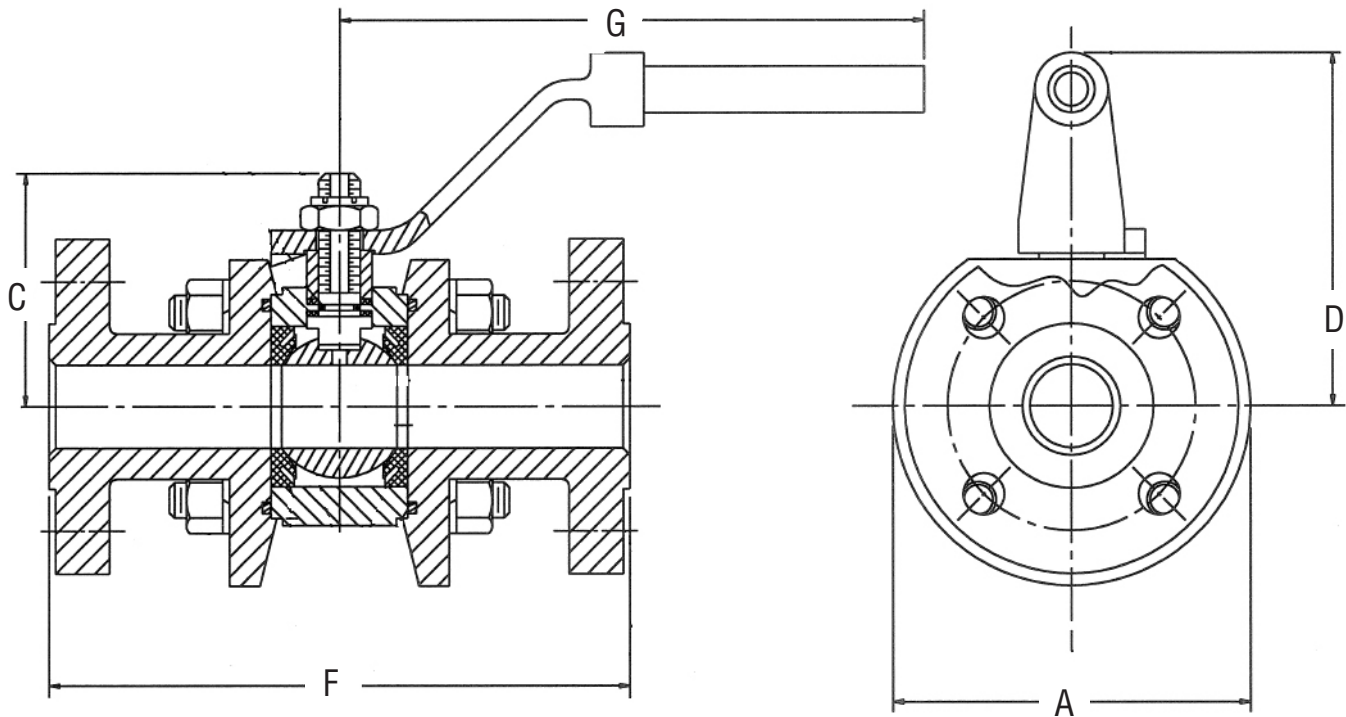

### Notes

Drawing has typical information only.

For installation purposes, use certified drawing.

### Pressure Class 300 (PN 50)

Fig. No.	Type	Ends	NPS (DN)
CBV95C	Ball	Flanged	3 (80) and 4 (100)

### Dimensions

Black numerals are in inches and pounds  
Colored numerals are in millimeters and kilograms

Figure No. CBV95C	NPS	3	4
	DN	80	100
A		8.3	10.5
		211	267
C		5.3	7.3
		135	185
D		7.1	9.3
		180	236
F		13.0	15.5
		330	394
G		16.0	25
		406	635
Weight Approx (lbs.)		88	173
		40.0	78.5
Cv		700	1400

Refer to page 155 for materials of construction.

Refer to pages 203 through 238 for the applicable pressure ratings.

## E-Series Ball Valves Standard Port, Class 600

Carbon or stainless steel ball valve with lever actuator

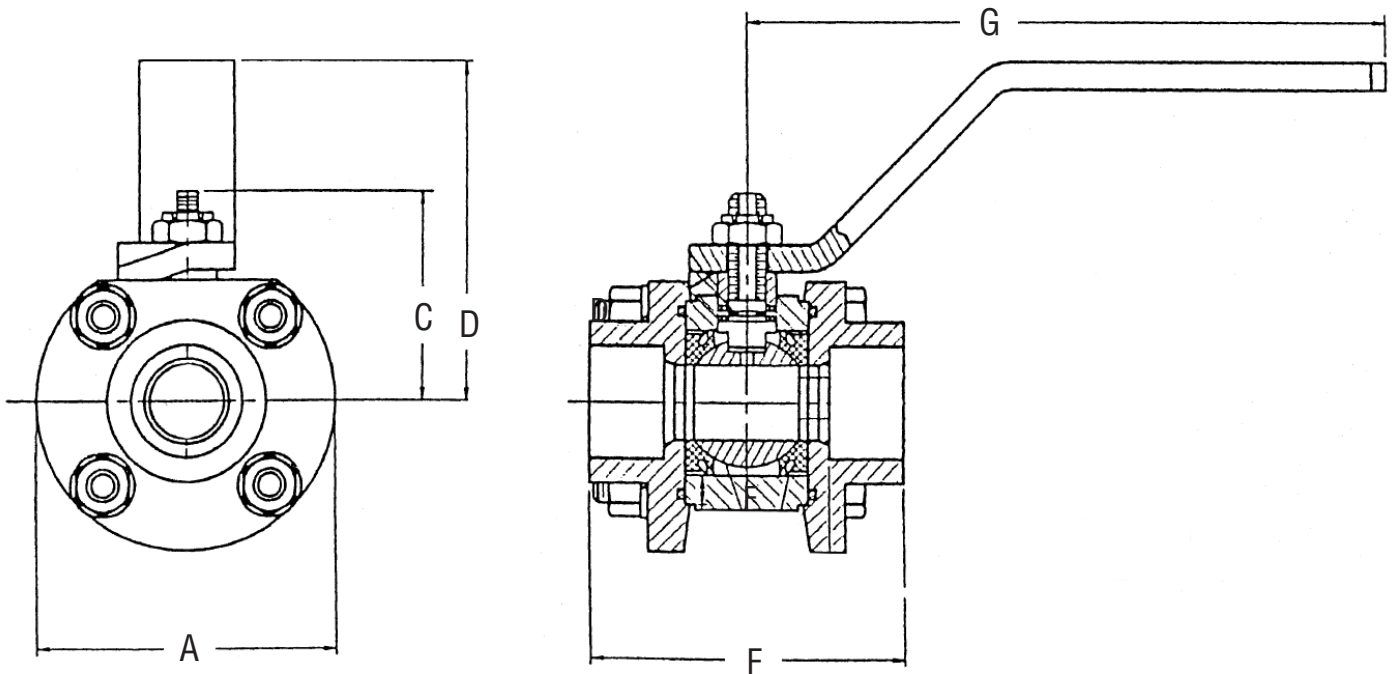

### Notes

Drawing has typical information only.  
For installation purposes, use certified drawing.

### Pressure Class 600 (PN 100)

Fig. No.	Type	Ends	NPS (DN)
EBV94S	Ball	Socket Weld	½ (15) thru 2 (50)

### Dimensions

Black numerals are in inches and pounds  
Colored numerals are in millimeters and kilograms

Figure No. EBV94S	NPS	¾	1	1¼	1½	2
	DN	20	25	32	40	50
A		2.8	3.3	3.8	4.3	5
		71	84	95	108	127
C		1.6	2.1	2.4	2.6	2.9
		41	53	61	66	74
D		2.5	3.3	4	4.3	4.6
		64	84	102	109	117
F		2.6	3.1	3.6	4	4.6
		66	79	91	102	117
G		6	6	7	7	9
		152	152	178	178	229
Weight Approx (lbs.)		2.9	4.7	7.3	10.4	15.8
		1.3	2.1	3.3	4.7	7.2
Cv		16.5	27	50	78	120

Refer to page 155 for materials of construction.  
Refer to pages 203 through 238 for the applicable pressure ratings.

## Ball Valves, Standard Port, E-Series, Flanged Ends, Class 600

Carbon or stainless steel ball valve with lever actuator

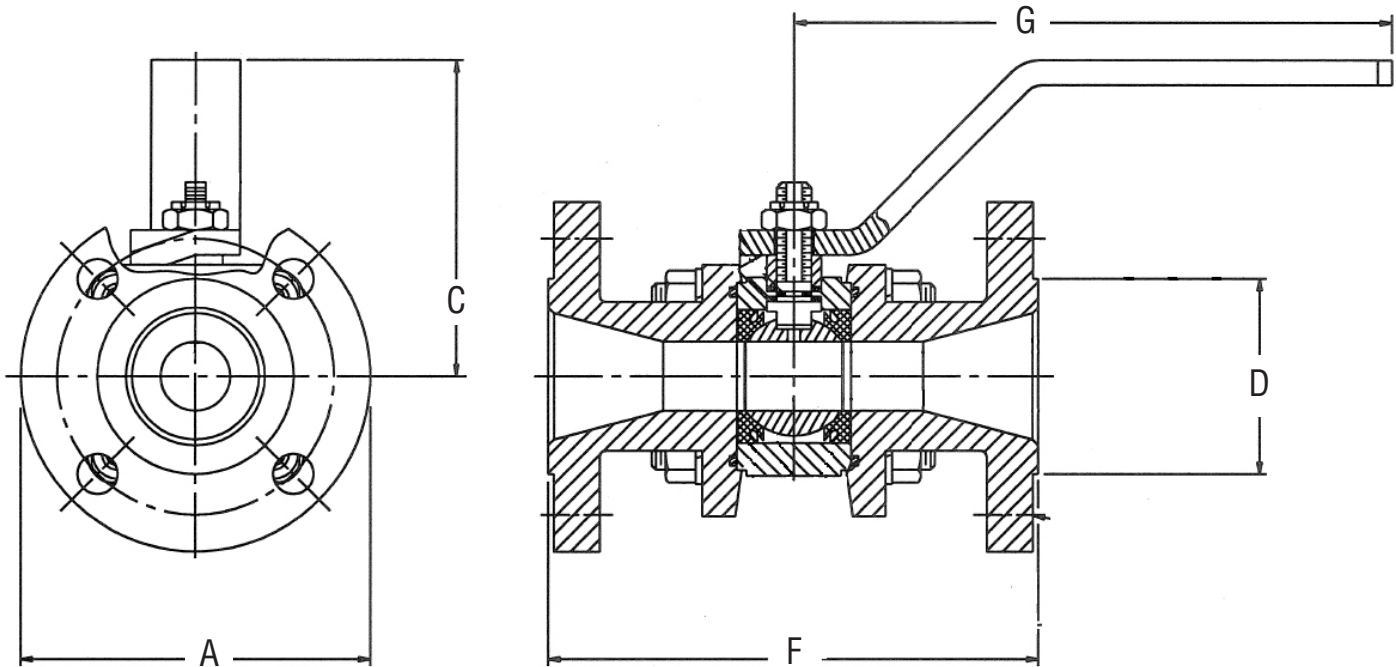

### Notes

Drawing has typical information only.

For installation purposes, use certified drawing.

### Pressure Class 600 (PN 110)

Fig. No.	Type	Ends	NPS (DN)
EBV94C	Ball	Flanged	¾ (20) thru 2 (50)

### Dimensions

Black numerals are in inches and pounds  
Colored numerals are in millimeters and kilograms

Figure No. EBV94C	NPS	¾	1	1¼	1½	2
	DN	20	25	32	40	50
A		4.6	4.9	5.3	6.1	6.5
		117	124	135	155	165
C		2.5	3.3	4	4.3	4.6
		64	84	102	109	117
D		1.7	2.0	2.5	2.9	3.6
		43	51	64	74	91
F		6.5	6.8	7.8	8.8	9.3
		165	173	198	224	236
G		6.0	6.0	7.0	7.0	9.0
		152	152	178	178	229
Weight Approx (lbs.)		11.6	14.1	20.7	29.6	36.5
		5.3	6.4	9.4	13.4	16.6
Cv		16.5	27	50	78	120

Refer to page 155 for materials of construction.

Refer to pages 203 through 238 for the applicable pressure ratings.

## E-Series Ball Valves Full Port, Class 600

Carbon or stainless steel ball valve with lever actuator

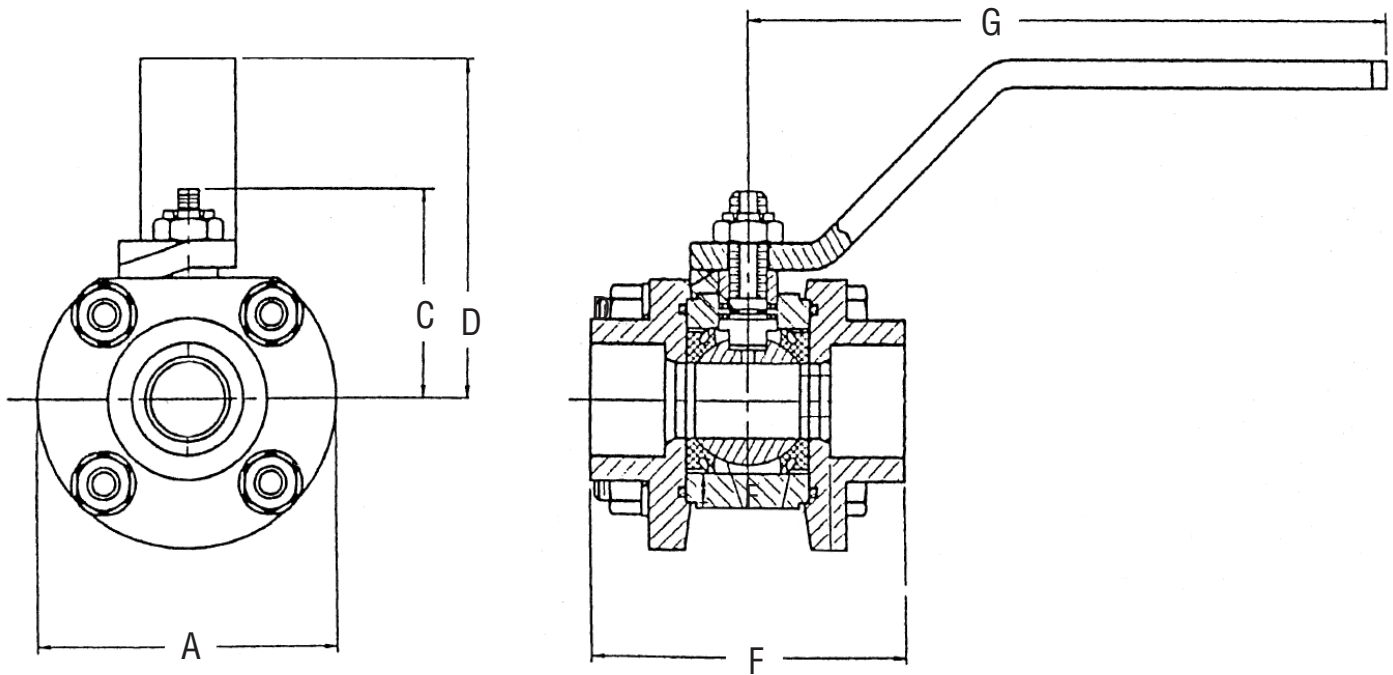

### Notes

Drawing has typical information only.  
For installation purposes, use certified drawing.

### Pressure Class 600 (PN 100)

Fig. No.	Type	Ends	NPS (DN)
EBV95S	Ball	Socket Weld	½ (15) thru 2 (50)

### Dimensions

Black numerals are in inches and pounds  
Colored numerals are in millimeters and kilograms

Figure No. EBV95S	NPS	½	¾	1	1¼	1½	2
	DN	15	20	25	32	40	50
A		2.8	3.3	3.8	4.3	5	6.3
		71	84	97	109	127	160
C		1.6	2.1	2.4	2.6	2.9	3.4
		41	53	61	66	74	86
D		2.5	3.4	4	4.3	4.6	5
		64	86	102	109	117	127
F		2.6	3.1	3.6	4	4.6	6
		66	79	91	102	117	152
G		6	6	7	7	9	9
		152	152	178	178	229	229
Weight Approx (lbs.)		2.9	4.7	7.3	10.4	15.8	23.8
		1.3	6.2	3.3	4.7	7.2	10.8
Cv		16.5	27	50	78	120	195

Refer to page 155 for materials of construction.  
Refer to pages 203 through 238 for the applicable pressure ratings.

# Ball Valves, Full Port, E-Series, Raised Face Flanged Ends, Class 600

Carbon or stainless steel ball valve with lever actuator

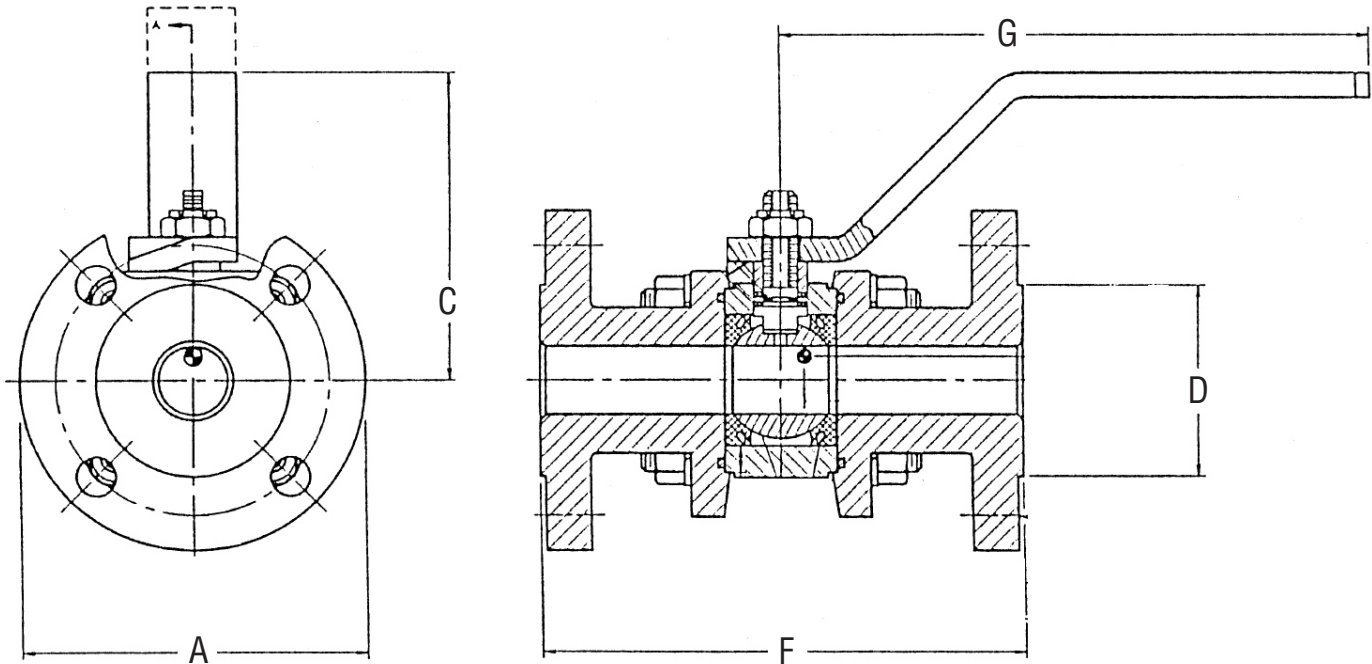

## Notes

Drawing has typical information only.

For installation purposes, use certified drawing.

## Pressure Class 600 (PN 100)

Fig. No.	Type	Ends	NPS (DN)
EBV95C	Ball	Flanged	½ (15) thru 2 (50)

## Dimensions

Black numerals are in inches and pounds  
Colored numerals are in millimeters and kilograms

Figure No. EBV95C	NPS	½	¾	1	1¼	1½	2
	DN	15	20	25	32	40	50
A		3.8	4.6	4.9	5.3	6.1	6.5
		97	117	124	135	155	165
C		2.5	3.4	4	4.5	4.6	5
		64	84	102	114	117	127
D		1.4	1.7	2.0	2.5	2.9	3.6
		36	43	51	64	74	91
F		6.5	6.8	7.8	8.8	9.3	11
		165	173	198	224	236	279
G		6	6	7	7	9	9
		152	152	178	178	229	229
Weight Approx (lbs.)		8.2	13	17.5	24	35	46.3
		3.7	5.9	7.9	10.9	15.9	21
Cv		16.5	27	50	78	120	195

Refer to page 155 for materials of construction.

Refer to pages 203 through 238 for the applicable pressure ratings.

## **Anchor/Darling Butterfly Valves**

## *Features and Description of Flowserve Anchor/Darling Butterfly Valves*



### ***High-Performance, Pressure-Assisted Seating***

Anchor/Darling has applied our vast knowledge and experience in materials, manufacturing and design to our butterfly valves. Anchor/Darling butterfly valves incorporate proven performance features into an economically designed package. The result is a valve that offers the optimum combination of performance and life-cycle cost.

So when you need the best value in a proven butterfly valve, specify Flowserve Anchor/Darling.

### ***Features That Ensure Dependable Operation***

- High operating pressures... to 1440 PSI.
- Excellent flow and throttling characteristics.
- High operating temperatures... to 500°F.
- High-performance, pressure-assisted bi-directional seat.
- Self-compensating seat design for maximum performance.
- Pressure-balanced shaft reduces thrust wear.
- Bubble-tight shut-off.
- Low torque for smooth and easy operation.
- Available with lift-to-unlock handle that automatically locks when released.
- Handle positions in 15-degree increments.
- Easily adaptable to automatic operation with electric, pneumatic or hydraulic actuators.
- Fourteen sizes from 3 inches to 48 inches inclusive.
- Suitable for vacuum service.
- Wide-band disc sealing area.
- Compact design cuts weight and space requirements.
- Heavy-duty corrosion-resistant shaft bearings.
- Adjustable shaft packing.
- Available in wafer, lugged, or flanged body design.
- Also available: Direct replacements for Contromatics butterfly valves.



## Approximate Weights by Valve Design (lb)

SIZE (in.)	150#L	150#W	300#L	300#W	600#L	600#W
3	33	30	35	30	40	35
4	45	40	45	40	65	50
6	60	55	65	55	130	70
8	125	115	135	115	215	147
10	175	156	200	156	417	306
12	240	170	275	200	556	425
14	350	270	570	325	648	498
16	450	345	790	510	858	693
18	600	450	1050	625	1148	884
20	850	540	1500	972	1568	1248
24	1300	750	2061	1200	—	—
30	2300	1700	—	—	—	—
36	3700	2850	—	—	—	—
48	—	5100	—	—	—	—

**Notes:** 1) Weights are approximate and believed to be conservative. Weights for larger valves will vary considerably with face-to-face dimensions. Always consult the factory when evaluating replacements for specific equipment. 2) Weights include an allowance for typical actuator mounting brackets.

## Standard Materials of Construction

### Anchor/Darling High-Performance Valves

#### Description for 3" through 36" Butterfly Valves (wafer and lugged design)

PART NO.	DESCRIPTION	MATERIAL CARBON STEEL	MATERIAL STAINLESS STEEL
1	SHAFT	17 – 4 PH	17 – 4 PH
2	GLAND RETAINER	CARBON STEEL	CARBON STEEL
3	GLAND RING	300 STAINLESS STEEL	300 STAINLESS STEEL
4	PACKING	GRAPHITE	GRAPHITE
5	GLAND RING	300 STAINLESS STEEL	300 STAINLESS STEEL
6	BUSHING	BRONZE	BRONZE
7	THRUST WASHER	BRONZE	BRONZE
8	DISC PIN	316 STAINLESS STEEL	316 STAINLESS STEEL
9	DISC	SEE NOTE #1	316 STAINLESS STEEL
10	BODY	CARBON STEEL	316 STAINLESS STEEL
11	O-RING	VITON OR EPR	VITON OR EPR
12	SEAT	SEE NOTE #2	SEE NOTE #2
13	SEAT RETAINER	CARBON STEEL	316 STAINLESS STEEL
14	NUT	CARBON STEEL	CARBON STEEL
15	STUD	CARBON STEEL	CARBON STEEL
16	SOCKET HD. CAP SCREW	ALLOY STEEL	ALLOY STEEL
17	SEAL (NOTE #3)	VITON OR EPR	VITON OR EPR
18	RETAINER (NOTE #3)	316 STAINLESS STEEL	316 STAINLESS STEEL

**Notes:** 1) 3" through 10" carbon steel valves supplied with 316 stainless disc, sizes 12" and above supplied with carbon steel disc with electroless nickel plating. 2) Standard valves are supplied with reinforced fluoropolymer seat. Ultra-high-molecular-weight polyethylene, tefzel and ethylene propylene seat materials are also available. 3) Applies to 24" through 36" sizes only. 4) 16" through 20" Class 300, 24" through 36" Class 150, and 10" through 20" Class 600 employ upper and lower shafts.

## Standard Materials of Construction

### Anchor/Darling High-Performance Valves

#### Description for 48" Class 150 Wafer Design

PART NO.	DESCRIPTION	MATERIAL CARBON STEEL	MATERIAL STAINLESS STEEL
1	BODY	CARBON STEEL	316 STAINLESS STEEL
2	UPPER SHAFT	17 – 4 PH	17 – 4 PH
3	HEX HEAD CAPSCREW	ALLOY STEEL	ALLOY STEEL
4	GLAND RING	300 STAINLESS STEEL	300 STAINLESS STEEL
5	O-RING (BODY)	VITON OR EPR	VITON OR EPR
6	O-RING (SHAFT)	VITON OR EPR	VITON OR EPR
7	BUSHING	BRONZE	BRONZE
8	THRUST WASHER	BRONZE	BRONZE
9	DISC	CARBON STEEL	316 STAINLESS STEEL
10	LOWER SHAFT	17 – 4 PH	17 – 4 PH
11	GASKET	NITRILE	NITRILE
12	SHAFT CAP	CARBON STEEL	316 STAINLESS STEEL
13	SEAT RETAINER	CARBON STEEL	316 STAINLESS STEEL
14	SEAT	SEE NOTE #2	SEE NOTE #2
15	PIN	316 STAINLESS STEEL	316 STAINLESS STEEL
16	PIN RETAINER	316 STAINLESS STEEL	316 STAINLESS STEEL
17	O-RING (PIN RETAINER)	VITON OR EPR	VITON OR EPR
18	SOCKET HEAD CAPSCREW	ALLOY STEEL	ALLOY STEEL
19	SHAFT COUPLING	CARBON STEEL	316 STAINLESS STEEL
20	KEY	CARBON STEEL	CARBON STEEL
21	TRAVEL STOP	CARBON STEEL	316 STAINLESS STEEL
22	SOCKET HEAD CAPSCREW	ALLOY STEEL	ALLOY STEEL
23	EYE BOLTS	CARBON STEEL	CARBON STEEL
24	LOCKWASHER	CARBON STEEL	STAINLESS STEEL
25	DRIVE SCREW	STAINLESS STEEL	STAINLESS STEEL
26	NAMEPLATE	STAINLESS STEEL	STAINLESS STEEL
27	NATIONAL BOARD TAG	STAINLESS STEEL	STAINLESS STEEL
28	JAM NUT	CARBON STEEL	CARBON STEEL
29	DISC ORIENTATION TAG	STAINLESS STEEL	STAINLESS STEEL

**Notes:** 1) Travel stop is optional. 2) Standard valves are supplied with EPR/EPDM seat. Reinforced fluoropolymer and ultra-high-molecular-weight polyethylene (UHMWPE) seats are also available. 3) National board tag is optional.

# Performance Characteristics

## Anchor/Darling High-Performance Valves

### Friction Loss versus Flow – Based on Water

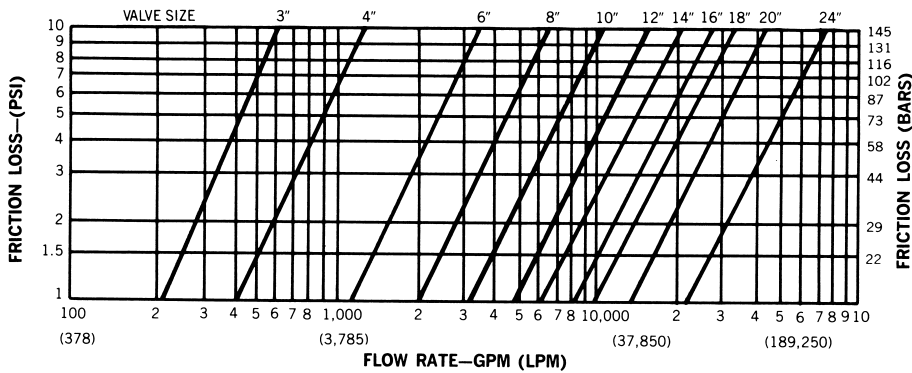

### Pressure/Temperature Capability

Class 150 and 300 ANSI

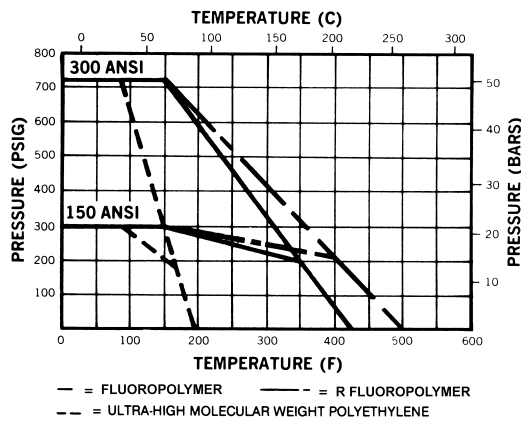

Class 600 ANSI

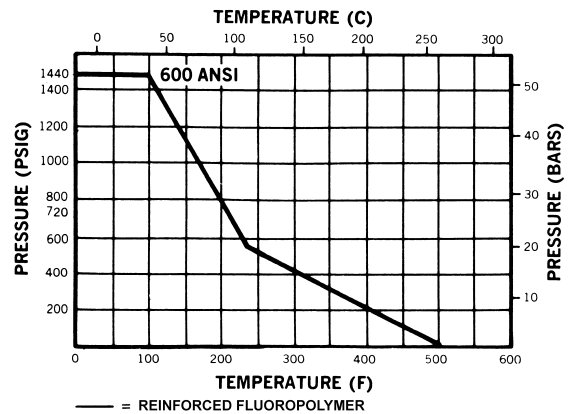

### Cv values

Size (inches)	150	300
3	210	210
4	400	400
6	1150	1150
8	2100	2100
10	3410	3410
12	6525	4800
14	8400	6100
16	11000	7400
18	14800	9600
20	18700	11900
24	22000	*
30	30000	*
36	50000	*
48	95000	*

### Flow Characteristics

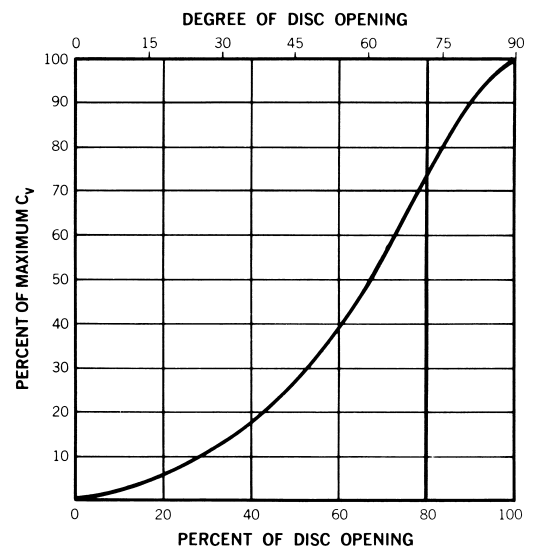

## Butterfly Valve, Class 150

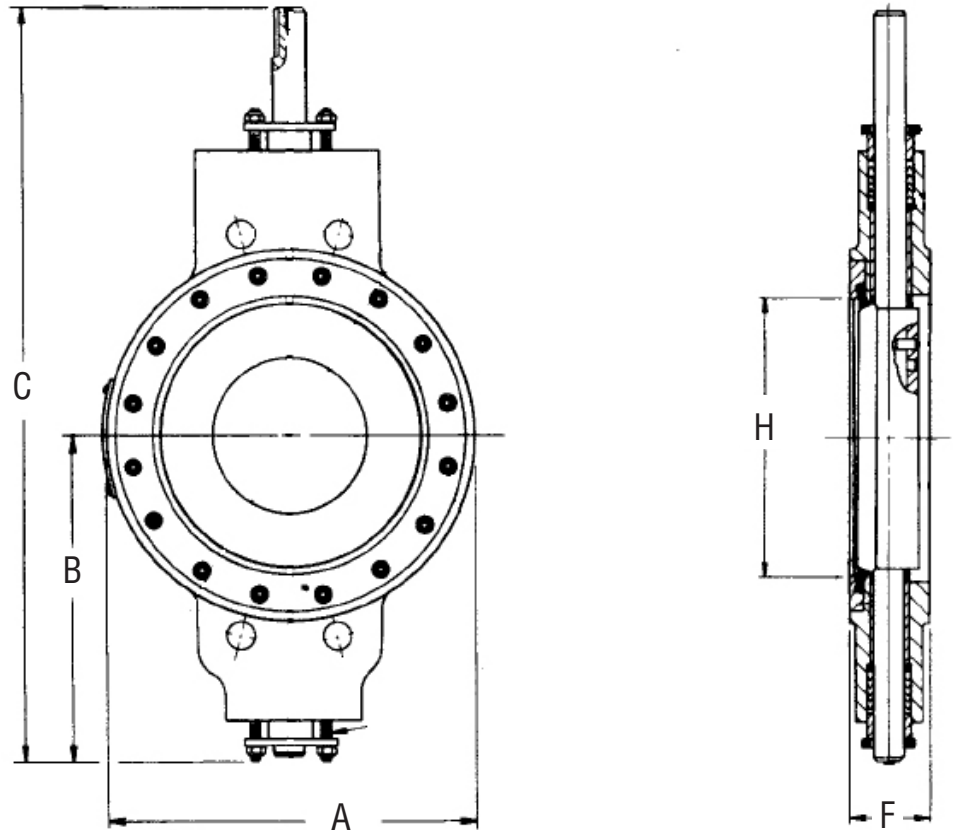

### Pressure Class 150 (PN 25)

Fig. No.	Type	Ends	NPS (DN)
BBF89V	Butterfly	Wafer	3 (80) thru 10 (250)

### Dimensions

Black numerals are in inches and pounds  
Colored numerals are in millimeters and kilograms

Figure No. BBF89V	NPS	3	4	6	8	10
	DN	80	100	150	200	250
A		5.1	6.8	8.9	10.9	13.1
		130	173	226	277	333
B		5.9	7.1	8	10.5	13.1
		150	180	203	267	333
C		12.5	15	17	19	25
		318	381	432	483	635
F		1.9	2.1	2.3	2.5	2.8
		48	53	58	64	71
H		2.8	3.9	5.8	7.6	9.5
		71	99	147	193	241

Dimensions are approximate and may vary. Always consult installation drawing.

Refer to page 177 for materials of construction.

Refer to pages 203 through 238 for the applicable pressure ratings.

## Butterfly Valve, Class 150

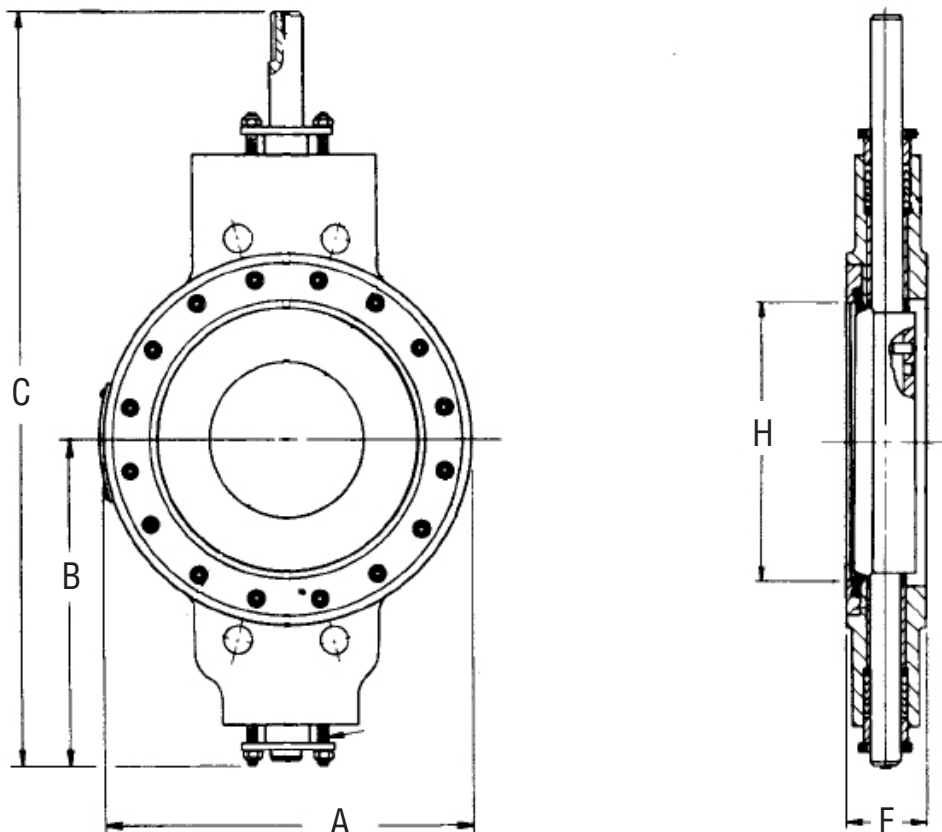

### Pressure Class 150 (PN 25)

Fig. No.	Type	Ends	NPS (DN)
BBF89V	Butterfly	Wafer	12 (300) thru 20 (500)

### Dimensions

Black numerals are in inches and pounds  
Colored numerals are in millimeters and kilograms

Figure No. BBF89V	NPS	12	14	16	18	20
	DN	300	350	400	450	500
A		15.1	16.4	20	21.3	23.3
		384	417	508	541	592
B		8.7	9.8	14.6	15.3	17.4
		221	249	371	389	442
C		21.7	24.6	32.8	34.1	38.2
		551	625	833	866	970
F		3.2	3.2	4.2	4.6	5.2
		81	81	107	117	132
H		11.8	12.9	14.8	16.7	18.7
		300	328	376	424	475

Dimensions are approximate and may vary. Always consult installation drawing.  
Refer to page 177 for materials of construction.  
Refer to pages 203 through 238 for the applicable pressure ratings.

## Butterfly Valve, Class 300

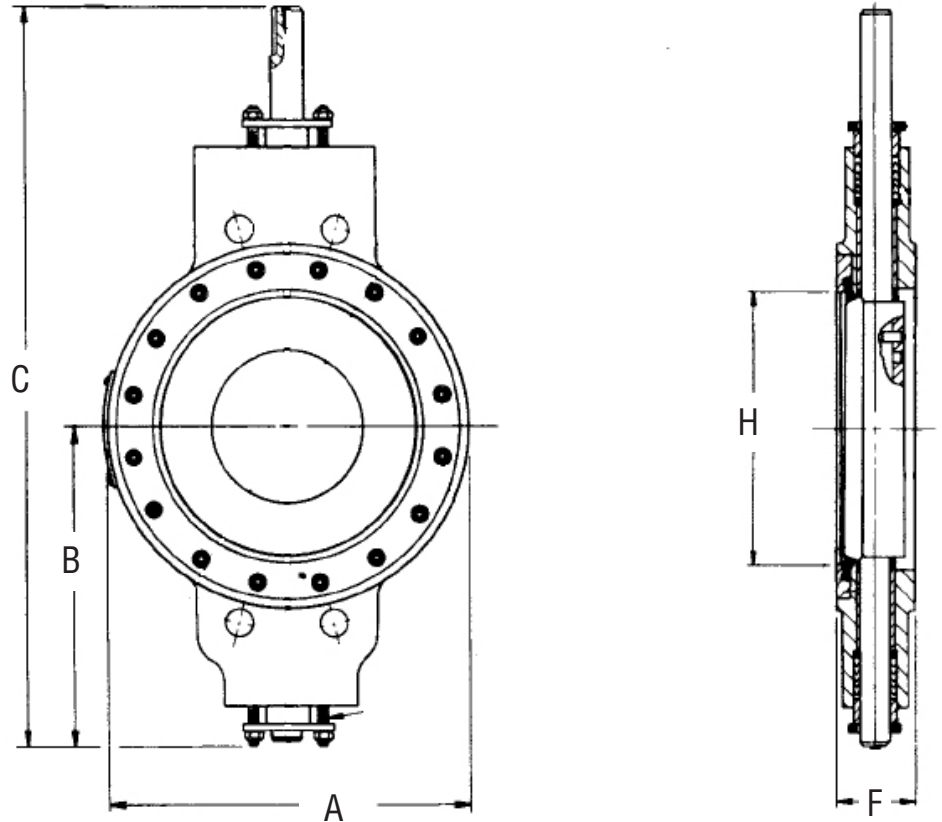

### Pressure Class 300 (PN 50)

Fig. No.	Type	Ends	NPS (DN)
CBF89V	Butterfly	Wafer	3 (80) thru 10 (250)

### Dimensions

Black numerals are in inches and pounds  
Colored numerals are in millimeters and kilograms

Figure No.	NPS	3	4	6	8	10	12	14	16	18	20
CBF89V	DN	80	100	150	200	250	300	350	400	450	500
A		5.1	6.8	8.9	10.9	13.1	15.8	17.4	18.6	21.1	23.1
		130	173	226	277	333	401	442	472	536	587
B		5.9	7.1	8	10.5	13.1	12.6	13.1	15.6	17.2	19.5
		150	180	203	267	333	320	333	396	437	495
C		12.5	15	17	19	25	29.8	31	32.5	35.9	43.5
		318	381	432	483	635	757	787	826	912	1,105
F		1.9	2.1	2.3	2.5	2.8	3.2	3.8	6.2	6.9	7.3
		48	53	58	64	71	81	97	157	175	185
H		2.8	3.9	5.8	7.6	9.5	11.4	12.8	14.8	16.6	18.5
		71	99	147	193	241	290	325	376	422	470

Dimensions are approximate and may vary. Always consult installation drawing.  
Refer to page 177 for materials of construction.  
Refer to pages 203 through 238 for the applicable pressure ratings.

## Butterfly Valve, Class 600

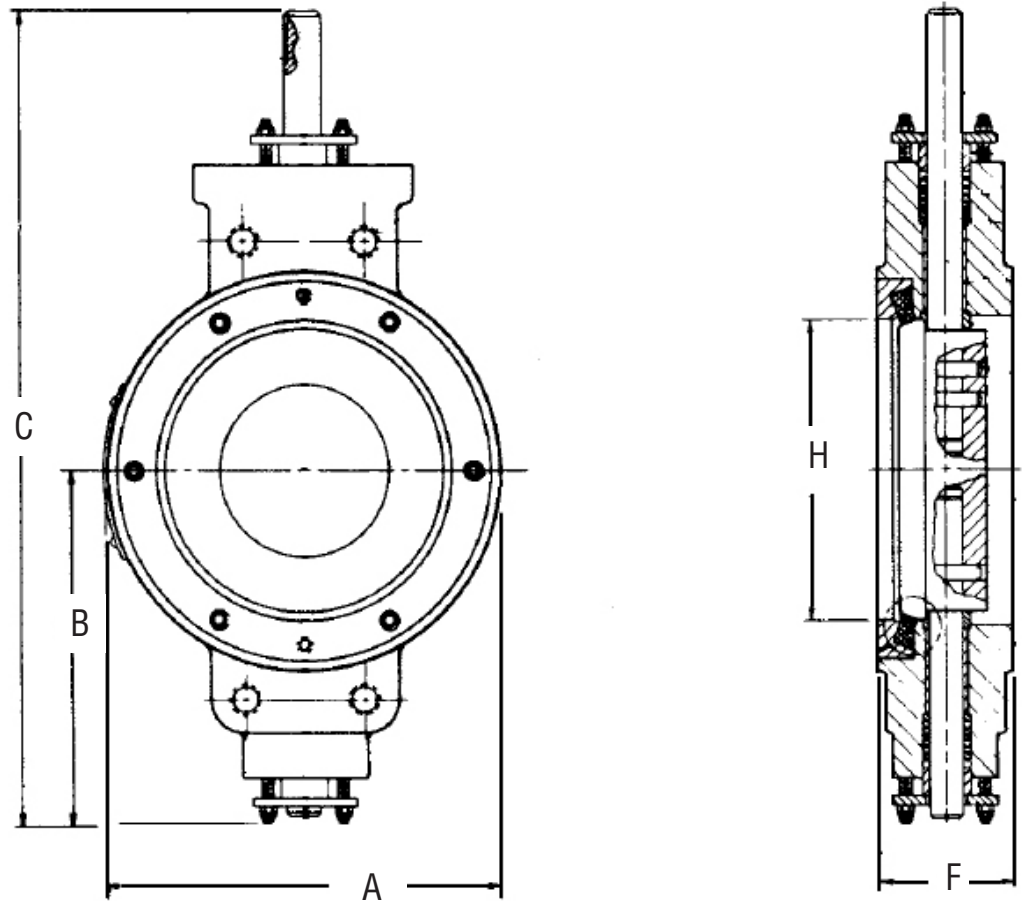

### Pressure Class 600 (PN 110)

Fig. No.	Type	Ends	NPS (DN)
EBF89V	Butterfly	Wafer	3 (80) and 4 (100)

### Dimensions

Black numerals are in inches and pounds  
Colored numerals are in millimeters and kilograms

Figure No. EBF89V	NPS	3	4
	DN	80	100
A		5.1	6.3
		130	160
B		4.8	5.8
		122	147
C		11.5	13.9
		292	353
F		2.4	2.5
		61	64
H		2.9	3.6
		74	91

Dimensions are approximate and may vary. Always consult installation drawing. Sizes 16" through 20" employ upper and lower shafts  
Refer to page 177 for materials of construction.  
Refer to pages 203 through 238 for the applicable pressure ratings.

## Butterfly Valve, Class 600

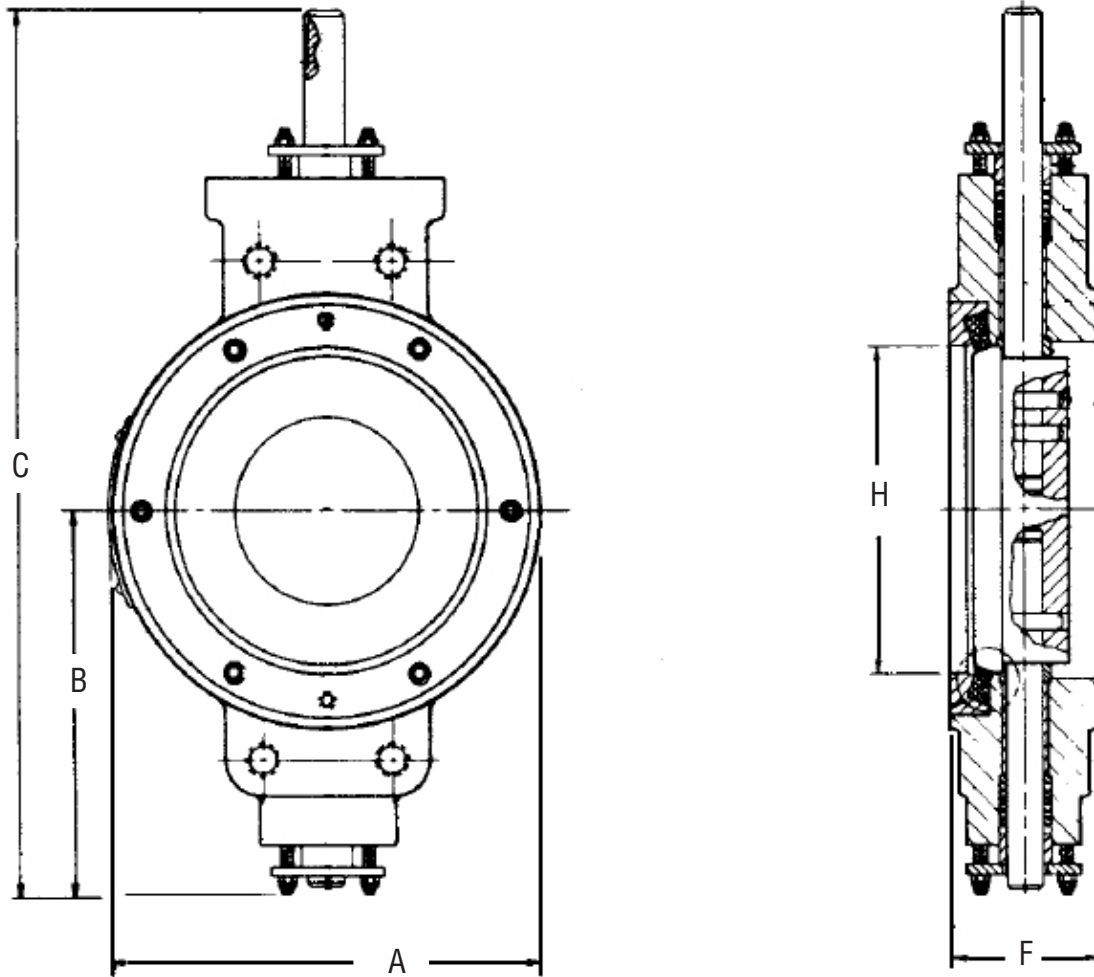

### Dimensions

Black numerals are in inches and pounds  
Colored numerals are in millimeters and kilograms

Figure No. EBF89V	NPS	6	8	10	12	14	16	18	20
	DN	150	200	250	300	350	400	450	500
A		8.6	10.7	12.9	15.3	16.4	18.8	21.3	23.3
		218	272	328	389	417	478	541	592
B		8.9	10.6	12.6	14.4	15.3	18.6	20.1	21.5
		226	269	320	366	389	472	511	546
C		19.8	22.9	27.1	31	33.3	39.4	43.6	46.3
		503	582	688	787	846	1,001	1,107	1,176
F		3.6	3.9	5.9	6.8	7.6	8.3	9.1	9.9
		91	99	150	173	193	211	231	251
H		5.8	7.3	9.8	11.4	12.5	14.3	16.1	18
		147	185	249	290	318	363	409	457

Dimensions are approximate and may vary. Always consult installation drawing.  
Refer to page 177 for materials of construction.  
Refer to pages 203 through 238 for the applicable pressure ratings.



## Butterfly Valve, Class 150

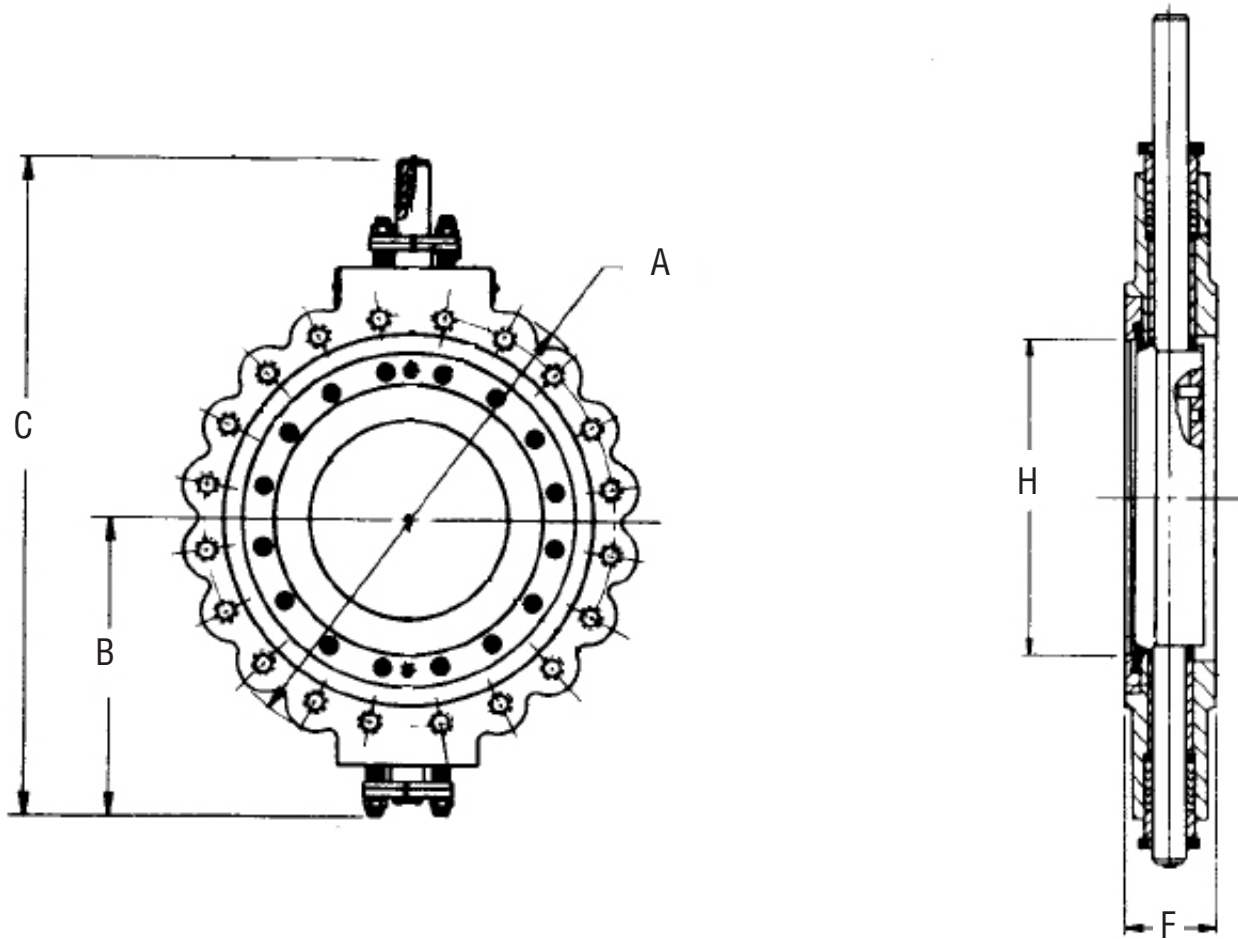

### Pressure Class 150 (PN 25)

Fig. No.	Type	Ends	NPS (DN)
BBF89L	Butterfly	Lugged	3 (80) thru 20 (500)

### Dimensions

Black numerals are in inches and pounds  
Colored numerals are in millimeters and kilograms

Figure No. BBF89L	NPS	3	4	6	8	10	12	14	16	18	20
	DN	80	100	150	200	250	300	350	400	450	500
A		7.5	9	11	13.5	16	19	21	23.5	25	27.5
		191	229	279	343	406	483	533	597	635	699
B		3.2	4.9	5.7	6.9	8.4	9.9	10.9	14.7	15.3	17.4
		81	124	145	175	213	251	277	373	389	442
C		9.8	12.4	14.9	18.1	19.5	22.9	25.6	32.8	34.1	38.2
		249	315	378	460	495	582	650	833	866	970
F		2	2.1	2.3	2.5	2.8	3.2	3.2	4.1	4.6	5.1
		51	53	58	64	71	81	81	104	117	130
H		2.8	3.9	5.8	7.6	9.8	11.8	12.9	14.8	16.7	18.7
		71	99	147	193	249	300	328	376	424	475

Refer to page 177 for materials of construction.

Refer to pages 203 through 238 for the applicable pressure ratings.

## Butterfly Valve, Class 300

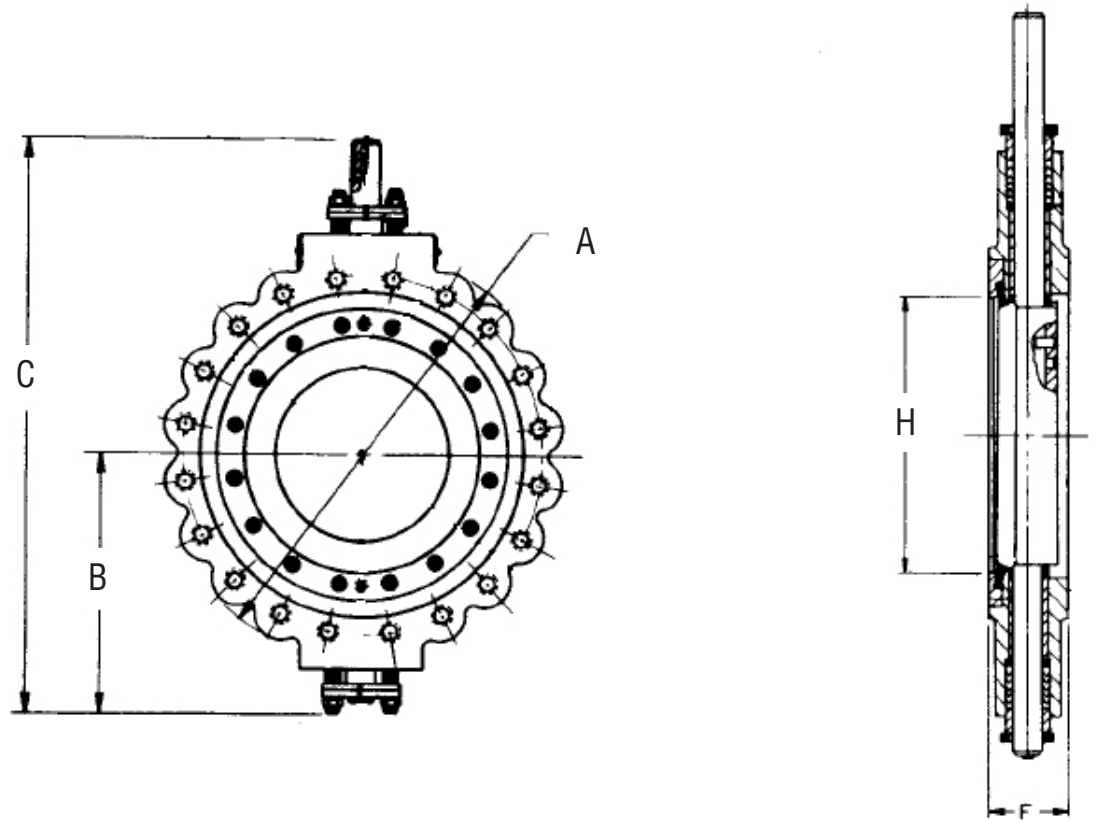

### Pressure Class 300 (PN 50)

Fig. No.	Type	Ends	NPS (DN)
CBL91L	Butterfly	Lugged	3 (80) thru 20 (500)

### Dimensions

Black numerals are in inches and pounds  
Colored numerals are in millimeters and kilograms

Figure No. CBL91L	NPS	3	4	6	8	10	12	14	16	18	20
	DN	80	100	150	200	250	300	350	400	450	500
A		8.3	10.0	12.5	15.0	17.5	20.5	23.0	25.5	28.0	30.5
		211	254	318	381	445	521	584	648	711	775
B		5.9	5.4	7.6	8.4	11.1	12.6	13.1	15.6	17.4	19.5
		150	137	193	213	282	320	333	396	442	495
C		12.5	12.9	16.9	19.6	26.8	29.8	31.0	32.5	35.9	43.1
		318	328	429	498	681	757	787	826	912	1,095
F		1.9	2.1	2.3	2.5	2.8	3.2	3.8	6.2	6.9	7.3
		48	53	58	64	71	81	97	157	175	185
H		2.8	3.9	5.8	7.6	9.5	11.4	12.8	14.8	16.6	18.5
		71	99	147	193	241	290	325	376	422	470

Refer to page 177 for materials of construction.

Refer to pages 203 through 238 for the applicable pressure ratings.

## Butterfly Valve, Class 600

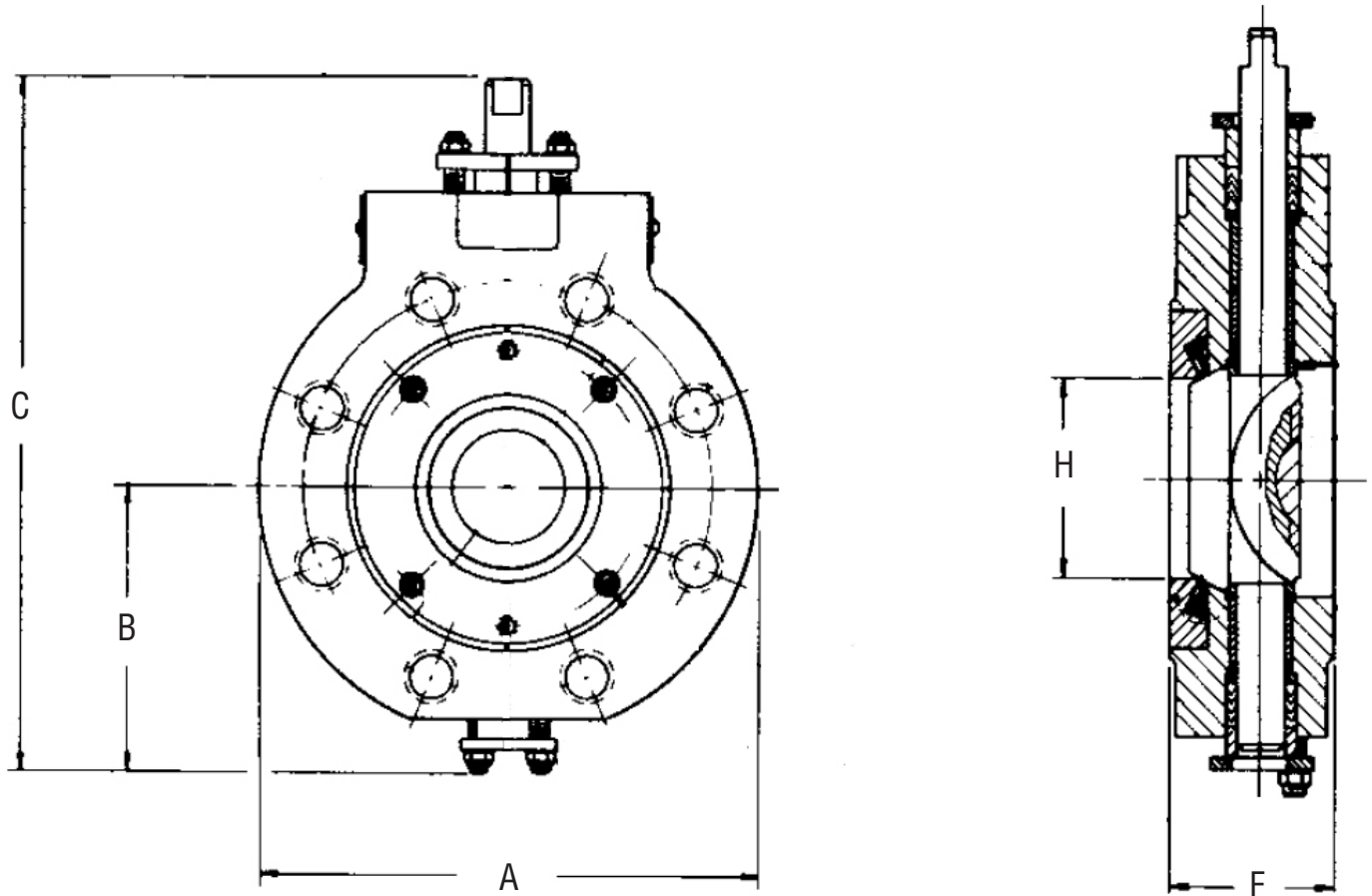

### Pressure Class 600 (PN 110)

Fig. No.	Type	Ends	NPS (DN)
EBF89L	Butterfly	Lugged	3 (80) thru 20 (500)

### Dimensions

Black numerals are in inches and pounds  
Colored numerals are in millimeters and kilograms

Figure No. EBF89L	NPS	3	4
	DN	65	80
A		8.3	10.8
		211	274
B		4.8	5.8
		122	147
C		11.5	13.9
		292	353
F		2.4	2.5
		61	64
H		2.9	3.6
		74	91

Dimensions are approximate and may vary. Always consult installation drawing.  
Refer to page 177 for materials of construction.  
Refer to pages 203 through 238 for the applicable pressure ratings.

## Butterfly Valve, Class 600

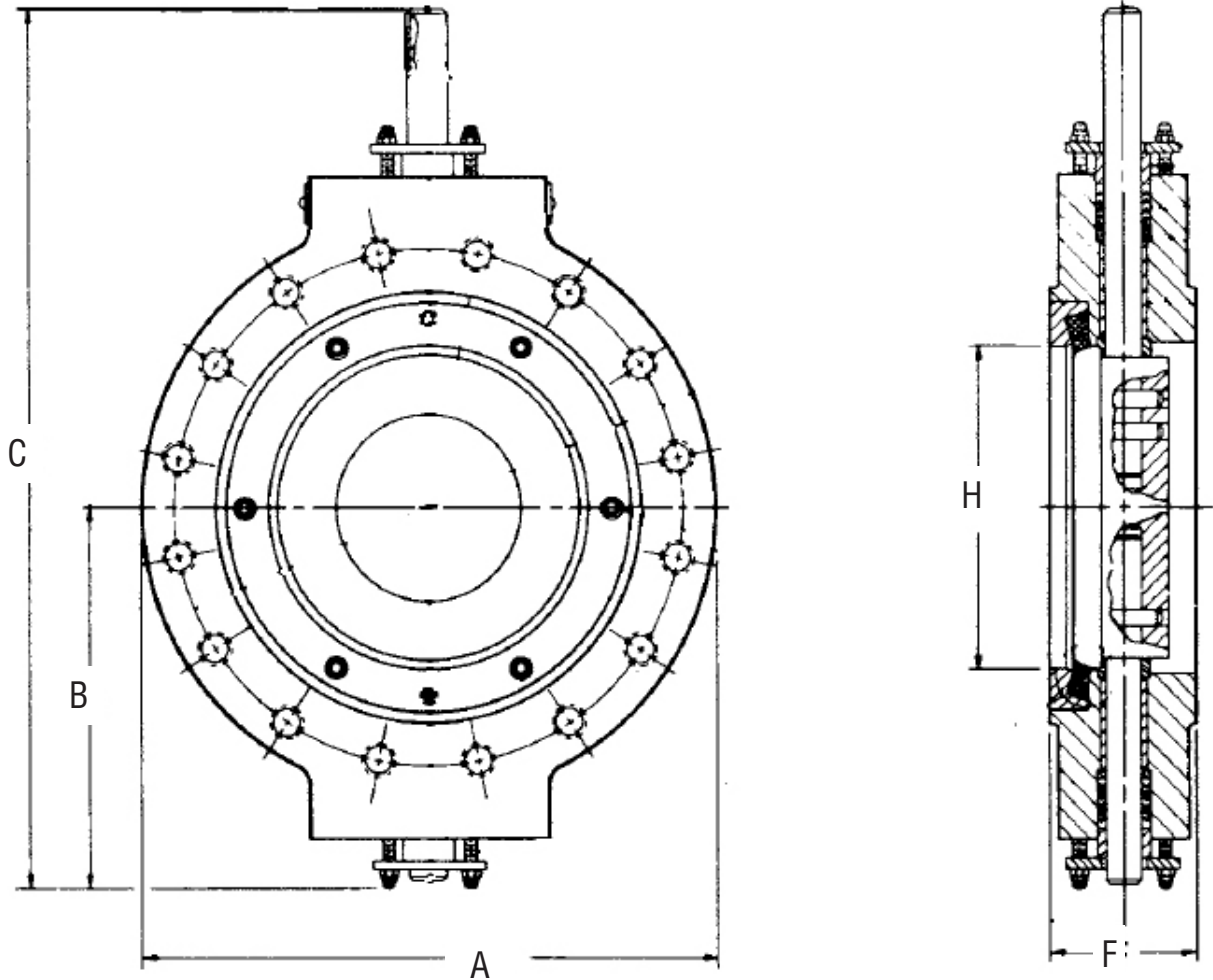

### Dimensions

Black numerals are in inches and pounds  
Colored numerals are in millimeters and kilograms

Figure No. EBF89L	NPS	6	8	10	12	14	16	18	20
	DN	150	200	250	300	350	400	450	500
A		14	16.5	20	22	23.8	27	29.3	32
		356	419	508	559	605	686	744	813
B		8.9	10.6	12.6	14.4	15.3	18.6	20.1	21.5
		226	269	320	366	389	472	511	546
C		19.8	22.9	27.1	31	33.3	39.4	43.6	46.3
		503	582	688	787	846	1,001	1,107	1,176
F		3.6	3.9	5.9	6.8	7.6	8.3	9.1	9.9
		91	99	150	173	193	211	231	251
H		5.8	7.3	9.8	11.4	12.5	14.3	16.1	18
		147	185	249	290	318	363	409	457

Dimensions are approximate and may vary. Always consult installation drawing.  
Refer to page 177 for materials of construction.  
Refer to pages 203 through 238 for the applicable pressure ratings.

## Special Applications Valves



## ***Special Applications Valves***

As Flowserve-Raleigh's products are supported with a highly experienced Technical Staff, the products can be adapted, modified or developed to handle special, critical applications. These products include multiple valve designs for Controlled Closure Check Valves and Excess Flow Check Valve. As new applications are identified, additional valve designs and products will be developed. Please consider Flowserve-Raleigh for all your critical nuclear valve applications, including those with new or special valve design requirements.

Contact your Flowserve-Raleigh Sales Manager for further information.

## Controlled Closure Check Valve

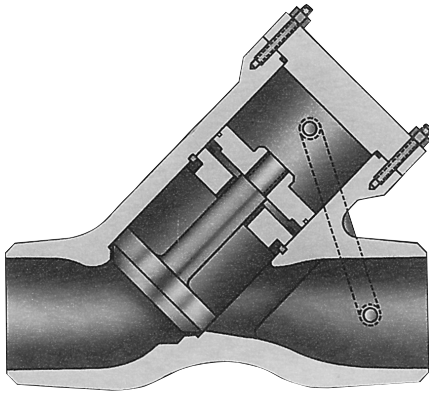

### Standard Features

- Minimizes waterhammer effects on postulated feedwater line break
- Computerized modeling verified by dynamic testing

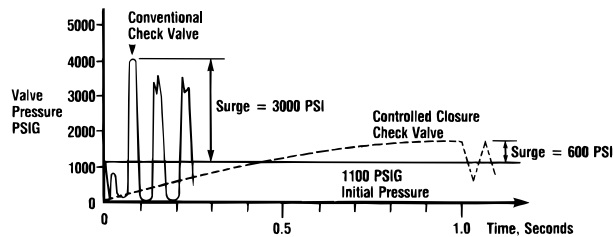
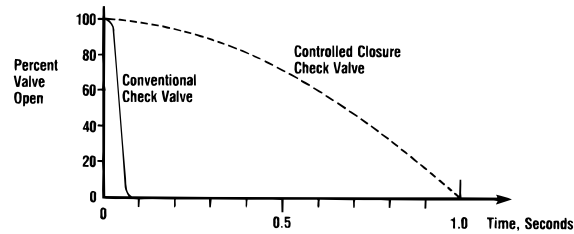

The Flowserve Edward Controlled Closure Check Valve was developed and qualified to serve a function that no other previous check valve could handle. If a feedwater line should rupture in a nuclear power plant, the reversed flow from the reactor or steam generator out of the containment boundary must be contained. Conventional check valves would close rapidly, but not fast enough to prevent high reverse flow velocity; closure of the conventional valve would produce severe pressure surges due to waterhammer—possibly severe enough to produce rupture of other piping or equipment.

The Controlled Closure Check Valve is much like a Flite-Flow piston lift check valve, but it has an integral “dashpot”—a plate with a close-clearance fit around the rod connecting the disc and piston. Flow paths sized for individual applications limit the flow out of the dashpot and consequently control the valve closing speed. See pg. 235-237 for a discussion of waterhammer and a comparison of the controlled closure check valve with other types.

As the final design section is very dependent on the specific application, consult with your Flowserve sales representative for more design details for this valve configuration.

## Excess Flow Check Valves – Sizes ½ through 2

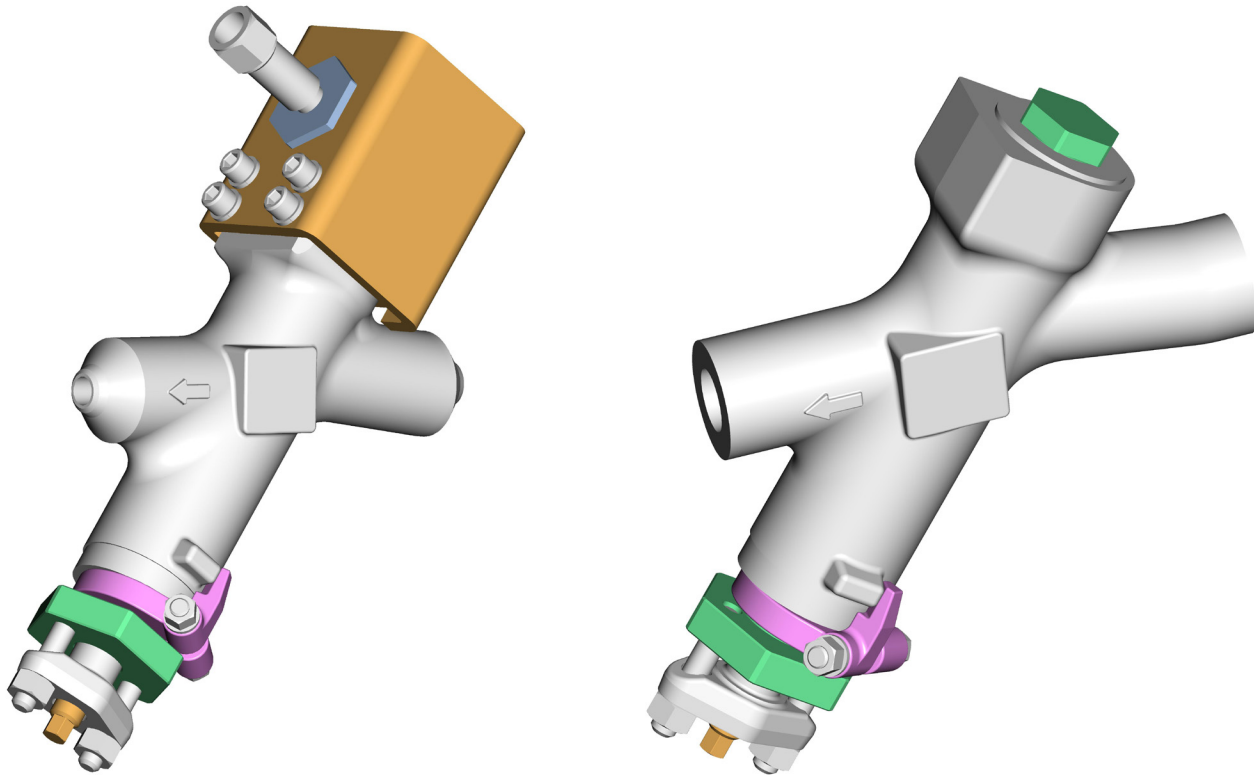

### Standard Features

- ASME Section III Design
- SA351-CF8M, others available upon request
- Pressure classes up to 2500
- Metal to Metal or Soft Seats
- Butt Weld or Socket Weld
- Full Open Cv – 2.6
- Option – Position Indication



## Excess Flow Check Valves – Sizes 2-½ and Larger

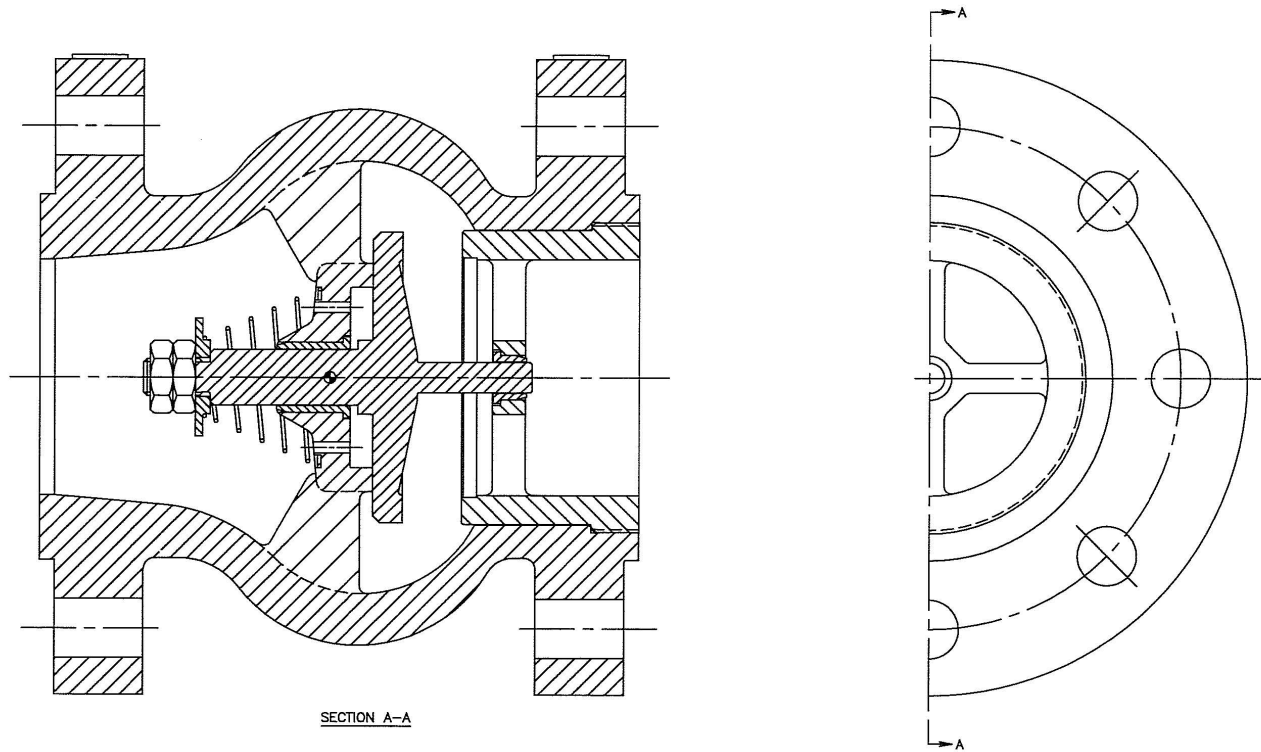

### Standard Features

- ASME Section III Design
- SA216-WCB or SA351-CF8M, others available upon request
- Pressure classes up to 1500
- Metal to Metal or Soft Seats
- Flanged or Butt Weld End
- Valve remains in open position allowing flow over the disc
- Maintains a “keep warm” position when required during turbine pump normal warm up condition
- Valve disc moves to closed position based on required calculated flows
- The valve spring is engineered to hold the disc firm and avoid disc oscillation

## Vacuum Breaker Valves – Sizes 2 and Larger

### Standard Features

- ASME Section III Design
- SA216-WCB or SA351-CF8M, others available upon request
- Pressure classes up to 1500
- Metal to Metal or Soft Seats
- Flanged or Butt Weld End

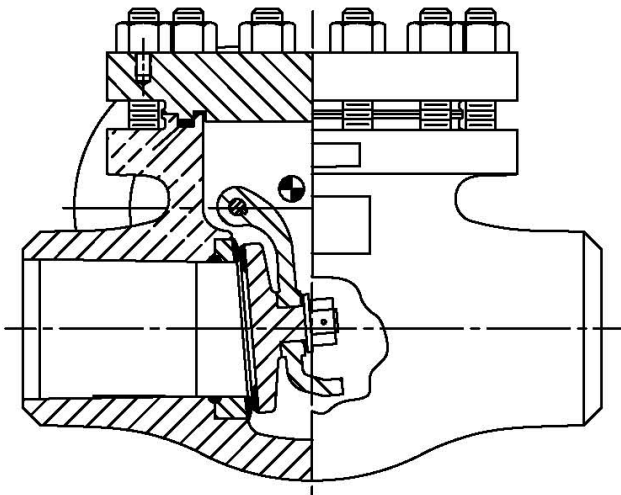
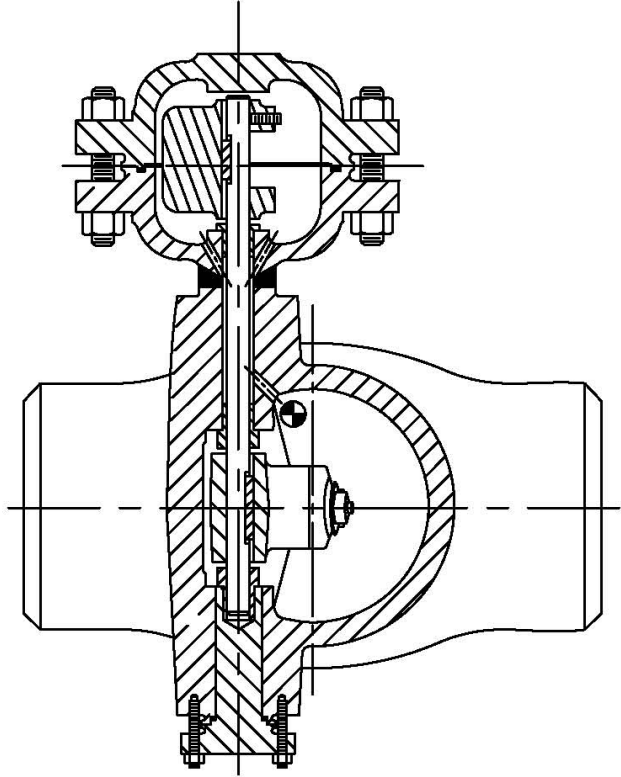

## **Accessories/Actuators**

## Accessories

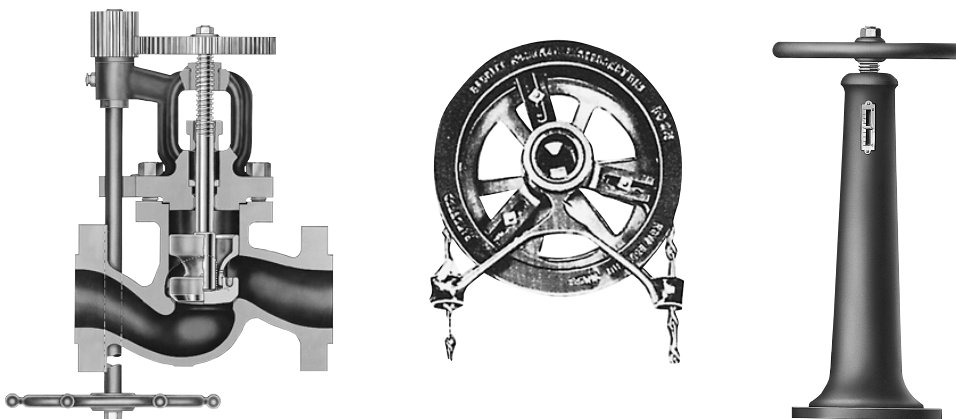

### Globe, Angle, Gate

By-Passes for Larger Cast Steel Valves (See Pg. 224)

Edward by-pass valves conform to the latest edition of MSS-SP45 of the Manufacturers Standardization Society of the Valve and Fittings Industry.

Unless otherwise specified when globe and angle valves are ordered with by-pass attached, the by-pass is attached to the left hand side of the valve when viewed from the overseat end.

### Edward Forged Steel Valves for use as by-passes

Socket Welding Ends Only		Class 600	Class 900	Class 1500	Class 2500	Series 4500
For use on main stop valve	Globe style, By-pass	Fig. A848Y*	Fig. D36224	Fig. D36224	Fig. D66224	Fig. D96224
For use on main stop-check valve	Globe style, By-pass	Fig. A868Y**	Fig. D36264	Fig. D36264	Fig. D66264	Fig. D96264

\* ALL MOTOR ACTUATED BY-PASS VALVES WILL BE FURNISHED WITH FIG. D36224.

\*\* ALL MOTOR ACTUATED BY-PASS VALVES WILL BE FURNISHED WITH FIG. D36264.

### Standard sizes of by-pass valves\*

Main valve size (all pressures)	4	5	6	8	10 to 24
By-Pass size	½	¾	¾	¾	1

\* By-passes are provided only when specified. Standard sizes of by-pass valves are in accordance with the table above. Larger size by-pass valves will be furnished on special order.

### Floor Stands

Edward floor stands are cast iron or fabricated steel, and are designed and machined for accurate alignment. They are regularly furnished painted and are faced on bottom and drilled. Two heights, 20 and 32 inches, are available and can be furnished in indicating or non-indicating types. Spur and motor control floor stands can be furnished to meet special conditions.

### Chain Wheels

A simple and efficient means of valve operation from a lower level is provided by the use of chain wheels. They are fitted to the regular valve handwheels and are furnished complete with chain wheel and chain guide.

### Valve Extension

Illustration shows spur geared valve with extension stem for operation from below. Valves can also be furnished for extension operation above the valve. Larger size valves are also available with bevel gearing.

## Accessories – Cast and Forged Steel

The following “accessories” or “options” are available for Edward forged and cast steel valves. Consult your Edward valves sales representative for specific details.

### Impactor Handwheel

Larger size Edward valves (except gate valves) feature an Impactor handwheel that permits one or two men to develop several thousand ft. lbs. of torque for final valve closure — up to twelve times the force of an ordinary handwheel.

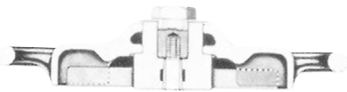

### Impactogear®

The Edward Impactogear makes cycling of larger, high-pressure valves a one-man operation. Impactogear is an exclusive Edward ring gear and pinion assembly that is fastened to an Impactor handwheel and yoke. Using the mechanical advantage of gearing reduction, the assembly permits large valves to be cycled between full open and full closed with an air wrench operating off a nominal air supply. The Impactogear wrench connection is equipped with a safety wrench guard.



### Custom Paint

Unless otherwise specified Edward cast and forged (carbon or alloy) steel valves are painted with a high-temperature aluminum lacquer paint. Upon special order, Edward valves can be provided with customer specified paints or coatings.

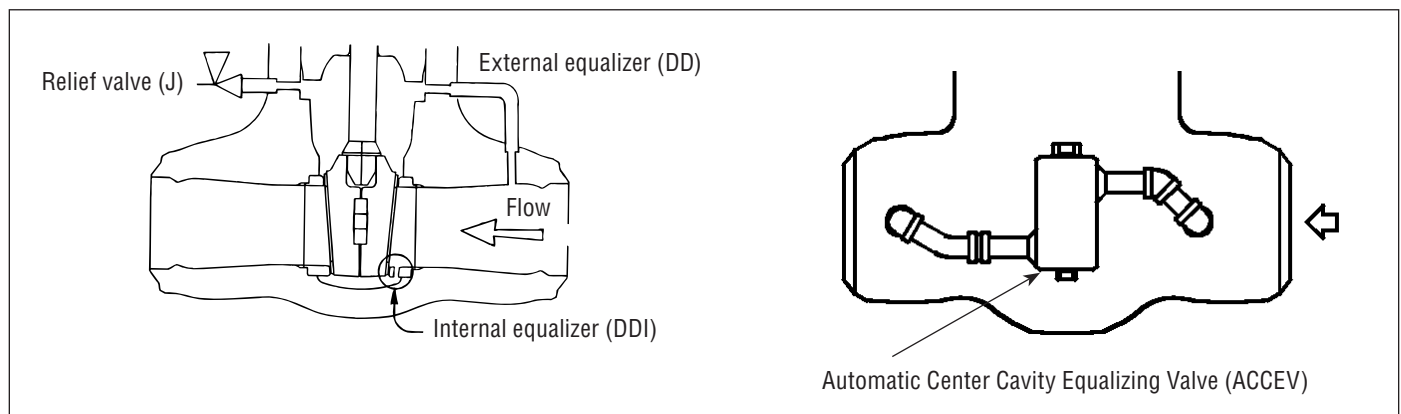

### Drain or Vent

All Edward cast steel valves can be supplied with drains and/or vents. A standard drain or vent pipe, six inches long, is socket welded to the valve body, or as specified by the customer.

### External Equalizer

A pipe that connects the bonnet cavity of the Equiwedge gate valve to the upstream side of the valve. See drawing and page 28 for additional information.

### Internal Equalizer

A hole drilled in the upstream seat ring of the Equiwedge Gate Valve for pressure equalization. See drawing and page 28 for additional information.

### Relief Valve

A pressure relief valve can be attached to the bonnet of the Equiwedge Gate Valve to protect against overpressurization, but not prevent pressure locking. See drawing and page 28 for additional information.

### Automatic Center Cavity Equalizing Valve

A fully automatic bonnet relief device that allows bi-directional seating even at low pressure differential. See drawing and page 198 for details.

## Accessories – Cast and Forged Steel

### Examples of a Typical Packing Leakoff (left) and Live Load Packing Gland (right)

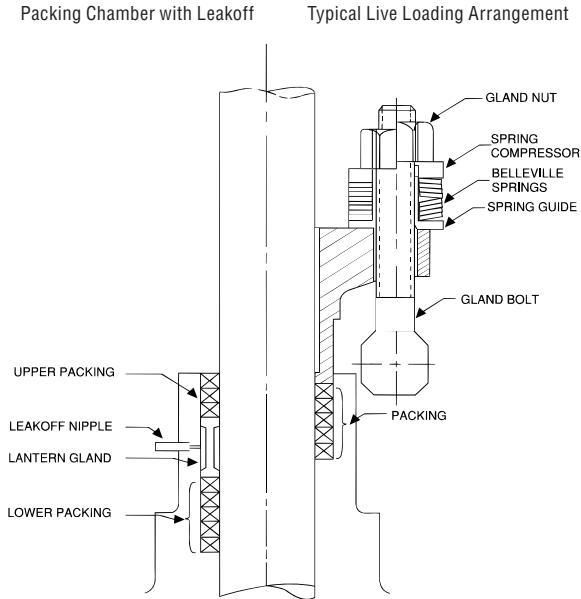

The following “accessories” or “options” are available for Flowserve Edward forged and cast steel valves. Consult your Flowserve Edward valves sales representative for specific details.

#### Leakoff

The left half of the schematic to the left depicts a typical Leakoff arrangement including lantern gland and upper and lower packing sets. This double-packing arrangement provides added protection against packing leaks.

#### Live Loading

The right half of the schematic to the left depicts a typical live loaded packing assembly. The Belleville springs provide a constant packing load to compensate for packing consolidation and thermal effects.

#### Locking Devices

Edward valves can be provided with padlock and chain or other locking devices as specified.

#### Position Indicators & Limit Switches

If required, Edward valves can be fitted with a variety of position indicators and/or limit switches for remote indication.

#### Soft Seats

This option is available for both forged and cast steel globe and check valves on a limited basis.

The disc face can be fitted with a soft seat or insert when drop tight sealing is a must. However, some limitations (temperature, differential pressure, radiation) may apply. Consult your Flowserve Edward valves representative for more information.

#### Washout Connections

Edward cast steel valves can be fitted with special covers that incorporate a pipe nipple to be used as a washout connection to introduce cleaning solutions, etc., for pipeline flushing.

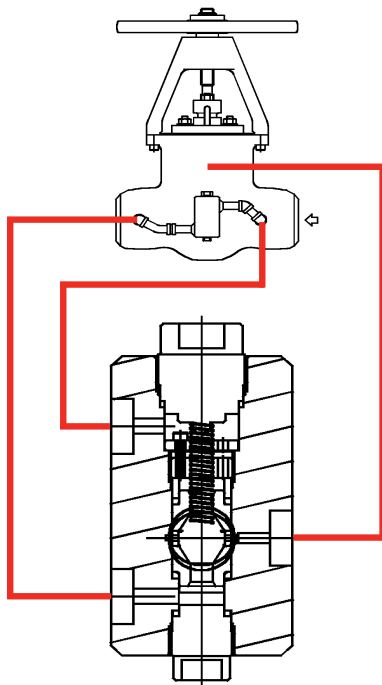

#### Automatic Center Cavity Equalizing Valve (ACCEV)

The Flowserve Edward ACCEV automatically relieves increasing center cavity pressure to the higher pressure end of the valve, while preventing leakage to the lower pressure end, solving pressure locking and bonnet over-pressurization problems that can occur in double-seated valves. The internal spring gives preferential connection to the designated upstream end of the valve. When system conditions result in the downstream pressure being higher than the upstream, the ball shifts so that the center cavity connects with the downstream end of the valve. The Edward ACCEV meets or exceeds MSS SP-61 for

tight shutoff in both directions. When furnished on an Edward Equiedge gate valve, all of the necessary connections are made to the host valve and hydro-tested in our factory. No piping connections or testing are required by the user. The Edward ACCEV is available as a kit with necessary piping to be field installed on any existing Edward or other manufacturer's valve, and can be readily disassembled and repaired in-line in the event any maintenance is required. The Edward ACCEV is available in a commercial B16.34 version for general service and also in an ASME Section III N-Stamp version for nuclear applications.

## ***Actuators – Forged and Cast Steel***

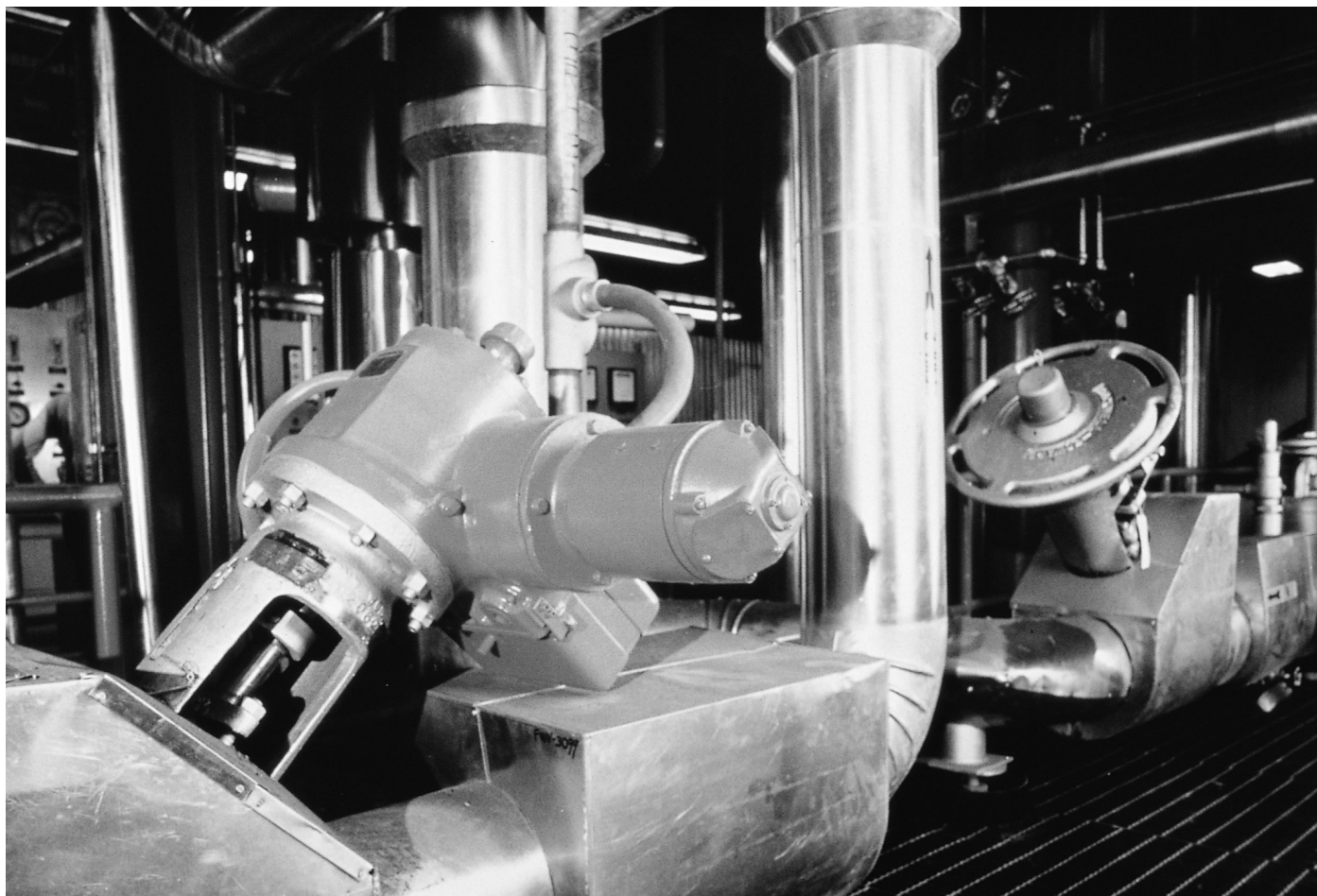

Flowserve Edward valves supply actuators for Edward forged and cast steel valves when alternate sources of power are required to open, close or maintain an intermediate position in the valve.

The most commonly used actuators are electric, pneumatic, hydraulic, manual gear or a stored energy gas hydraulic used in nuclear applications. Most Edward valves can be equipped with an actuator, if required. Where specific or special customer requirements are needed, Flowserve engineering and expertise with all types of actuators can be applied and adapted to meet the most rigid codes.

The following information on page 200 will allow Flowserve engineers to correctly size and select the proper motor actuator for your application.



## Required Information for Motor Actuators

### 1. OPERATING PRESSURES:

- A) PRESSURE UNDER SEAT = \_\_\_\_\_ psig
- B) PRESSURE OVER SEAT = \_\_\_\_\_ psig
- C) PRESSURE DIFFERENTIAL = \_\_\_\_\_ psig

### 2. MOTOR POWER SUPPLY\*:

- A) AC = \_\_\_\_\_ V. \_\_\_\_\_ HZ. \_\_\_\_\_ PH. \_\_\_\_\_
- B) DC = \_\_\_\_\_ V.

\*STANDARD VOLTAGE VARIANCE  $\pm$  10%, IF OTHERWISE, PLEASE INDICATE

3. LIMIT SWITCH, TOTAL QUANTITY OF CONTACTS = \_\_\_\_\_

4. DOUBLE TORQUE SWITCH IS STANDARD.

5. CONTROL POWER SUPPLY TO SWITCH COMPARTMENT = \_\_\_\_\_

### 6. CLOSING TIME:

- A) STANDARD (GLOBE VALVES APPROX. 4 IN./MIN., GATE VALVES APPROX. 12 IN./MIN. STEM SPEED.)
- B) SPECIAL \_\_\_\_\_ INDICATE REQUIRED CLOSING TIME: \_\_\_\_\_

### 7. OPTIONAL EQUIPMENT: (PLEASE INDICATE REQUIRED OPTIONS)

- A) MECHANICAL DIAL POSITION INDICATOR
- B) EXTRA TERMINALS
- C) REVERSING MOTOR CONTROLLER: \_\_\_\_\_ INTEGRAL OR \_\_\_\_\_ NON-INTEGRAL.
- D) PUSH-BUTTON STATION: \_\_\_\_\_ INTEGRAL OR \_\_\_\_\_ NON-INTEGRAL.
- E) POSITION TRANSMITTER, INDICATE TYPE \_\_\_\_\_
- F) POSITION RECEIVER \_\_\_\_\_
- H) OTHERS \_\_\_\_\_

8. AMBIENT CONDITIONS: \_\_\_\_\_

9. NEMA RATING: STANDARD IS NEMA 4 (WEATHERPROOF), IF OTHERWISE, PLEASE LIST

### 10. STEM POSITION OF INSTALLED VALVE:

- A) VERTICAL UP-RIGHT \_\_\_\_\_
- B) VERTICAL UP-SIDE DOWN \_\_\_\_\_
- C) HORIZONTAL \_\_\_\_\_

Data in the Table above represents the minimum information that should be provided when ordering a valve equipped with a motor operator.



## Tables and Charts

## Material Chemical Analysis (ASME or ASTM)

MATERIAL	ELEMENTS	PERCENTAGE*		
		CAST	FORGED	
<b>Carbon Steel (Body)</b> Cast - ASME SA-216 Grade WCB Forged - ASME SA-105	Carbon	0.30 max.	0.35 max.	
	Manganese	1.00 max.	.60 to 1.05	
	Phosphorus	0.04 max.	0.035 max.	
	Sulfur	0.045 max.	0.040 max.	
	Silicon	0.60 max.	0.10-0.35 max.	
<b>Carbon Steel (Body)</b> Cast - ASME SA-216 Grade WCC	Carbon	0.25 max.	0.22 max.	
	Manganese	1.20 max.	.60 to 1.05	
	Phosphorus	0.04 max.	0.04 max.	
	Sulfur	0.045 max.	0.05 max.	
	Silicon	0.60 max.	0.35 max.	
<b>2¼ Chromium-Molybdenum Steel (Body)</b> Cast - ASME SA-217 Grade WC9 Forged - ASME SA-182 Grade F22	Carbon	0.015	0.05-0.15	
	Manganese	0.40 to 0.70	0.30 to 0.60	
	Phosphorus	0.04 max.	0.04 max.	
	Sulfur	0.045 max.	0.04 max.	
	Silicon	0.60 max.	0.50 max.	
	Chromium	2.00 to 2.75	2.00 to 2.50	
	Molybdenum	0.90 to 1.20	0.87 to 1.13	
<b>Austenitic Stainless Steel (Body)</b> Cast - ASME SA-351 Grade CF8M Forged - ASME SA-182 Grade F316	Carbon	0.03 max.	0.08 max.	
	Manganese	1.50 max.	2.00 max.	
	Phosphorus	0.04 max.	0.045 max.	
	Nickel	9.00 to 13.00	10.00 to 14.00	
	Sulfur	0.04 max.	0.03 max.	
	Silicon	1.50 max.	1.00 max.	
	Chromium	17.00 to 21.00	16.00 to 18.00	
	Molybdenum	2.00 to 3.00	2.00 to 3.00	
<b>Martensitic Stainless Steel (Stems)</b> Bolted Bonnet T416 Cast Valves - ASME A-182 Grade F6a Univalves - A-479 T-410 Cl 3	Carbon	0.15 max.	0.15 max.	
	Manganese	1.00 max.	1.25 max.	
	Phosphorus	0.04 max.	0.06 max.	
	Sulfur	0.03 max.	0.15 min.	
	Silicon	1.00 max.	1.00 max.	
	Nickel	0.50 max.	—	
	Chromium	11.50 to 13.50	12.00 to 14.00	
	Molybdenum	—	0.60 max.	
<b>Aluminum Bronze (Yoke Bushings)</b> Cast Valves - ASTM B-148 Alloy 95400 Forged Valves - ASTM B-150 Alloy 61900-62300			61900	62300
	Copper	remainder	remainder	remainder
	Aluminum	10.00 to 11.50	8.50 to 10.00	8.50 to 11.00
	Iron	3.00 to 5.00	3.00 to 4.50	2.00 to 4.00
	Tin	—	0.60 max.	0.60 max.
	Lead	—	0.80 max.	—
	Manganese	0.50 max.	—	0.50 max.
	Zinc	—	0.02 max.	—
	Silicon	—	—	0.25 max.
	Nickel & Cobalt	1.50 max.	—	1.00 max.
<b>Chromium-Molybdenum (Bolting)</b> ASME SA-193 Grade B7 Forged - ASME SA-105	Carbon	0.37 to 0.49	0.35 max.	
	Manganese	0.95 to 1.10	0.60 to 1.05 max.	
	Phosphorus	0.035 max.	0.035 max.	
	Sulfur	0.04 max.	0.040 max.	
	Silicon	0.15 to 0.35	0.10 to 0.35 min.	
	Chromium	0.75 to 1.20	0.30 max.	
	Molybdenum	.015 to 0.25	0.12 max.	
<b>Hard Surfacing for Seats and Discs</b> A732 Grade 21 & Stellite 21®	Chromium		25.00 to 29.00	
	Manganese		1.00 max.	
	Molybdenum		5.00 to 6.00	
	Nickel		1.75 to 3.75	
	Iron		3.00	
	Boron		.007 max.	
	Carbon		0.20 to 0.30	
	Silicon		1.00	

This ASME/ASTM specification data is provided for customer information. The data was based on information available at time of printing and may not reflect the latest ASME/ASTM revision. Flowserve suggests referring to the applicable specification for complete information or contacting your Flowserve Valves sales representative.

\*The equivalent Flowserve valve material specification for valve bodies meets the requirements of the referenced ASME Specification; additionally Flowserve restricts certain elements (i.e. carbon, manganese) to tighter allowable ranges to enhance weldability.

## Reference: ASME B16.34 – 2009 Pressure/Temperature Ratings\*

### Forged Steel, Bolted Bonnet

VALVE TYPE	TEMPERATURE °F	PRESSURE (PSIG)
		SA105 (1)
<b>FLANGED END ONLY</b> <b>B16.34 STANDARD CLASS 600</b> <b>(2)</b>	-20 to 100	1480
	200	1360
	300	1310
	400	1265
	500	1205
	600	1135
	650	1100
	700	1060
	750	1015
	800	825
	850	640
	900	460
	950	275
	1000	170

**IMPORTANT: The above ratings are only for reference. Refer to ASME B16.34 for pressure/temperature ratings.**

1. Permissible but not recommended for prolonged use at temperatures above approx. 800°F.

2. Shaded ratings exceed those of Edward Valves. Consult your Flowserve sales representative for applications in these ranges.

\* Consult the applicable version of ASME section III for the correct version of ASME B16.34 to use.

## Reference: ASME B16.34 – 2009 Pressure/Temperature Ratings (metric)\*

### Forged Steel, Bolted Bonnet

1 bar = 100 kPa = 14.50 psi

VALVE TYPE	TEMPERATURE °C	PRESSURE (BAR)
		SA105 (1)
<b>FLANGED END ONLY</b> <b>B16.34 STANDARD CLASS 600</b> <b>(2)</b>	-29 to 38	102.1
	50	100.2
	100	93.2
	150	90.2
	200	87.6
	250	83.9
	300	79.6
	325	77.4
	350	75.1
	375	72.7
	400	69.4
	425	57.5
	450	46.0
	475	34.9
	500	23.5
538	11.8	

**IMPORTANT: The above ratings are only for reference. Refer to ASME B16.34 for pressure/temperature ratings.**

1. Permissible but not recommended for prolonged use at temperatures above approx. 427°C.

2. Shaded ratings exceed those of Edward Valves. Consult your Flowserve sales representative for applications in these ranges.

\* Consult the applicable version of ASME section III for the correct version of ASME B16.34 to use.

## Reference: ASME B16.34 – 2009 Pressure/Temperature Ratings\*

### Cast Steel\*\* (Gate, Globe & Check Valves)

MATERIAL	TEMP °F	PRESSURE (PSIG)							
		Class 150	Class 300	Class 600	Class 800	Class 900	Class 1500	Class 1878	Class 1888
SA216 WCB Standard Class (1) (2) (3)	100	285	740	1480	1975	2220	3705	4635	4660
	200	260	680	1360	1810	2035	3395	4250	4270
	300	230	655	1310	1745	1965	3270	4095	4115
	400	200	635	1265	1690	1900	3170	3970	3990
	500	170	605	1205	1610	1810	3015	3775	3795
	600	140	570	1135	1515	1705	2840	3555	3575
	650	125	550	1100	1465	1650	2745	3435	3455
	700	110	530	1060	1415	1590	2665	3330	3350
	750	95	505	1015	1350	1520	2535	3175	3195
	800	80	410	825	1100	1235	2055	2575	2590
	850	65	320	640	850	955	1595	1995	2005
	900	50	230	460	615	690	1150	1440	1445
	950	35	135	275	365	410	685	860	865
	1000	20	85	170	225	255	430	540	540
SA216 WCB Special Class (1) (2) (3)	100	290	750	1500	2000	2250	3750	4695	4720
	200	290	750	1500	2000	2250	3750	4695	4720
	300	285	740	1480	1975	2220	3700	4635	4660
	400	280	735	1465	1955	2200	3665	4585	4610
	500	280	735	1465	1955	2200	3665	4585	4610
	600	280	735	1465	1955	2200	3665	4585	4610
	650	275	715	1430	1905	2145	3575	4475	4500
	700	265	690	1380	1845	2075	3455	4325	4350
	750	245	635	1270	1695	1905	3170	3970	3990
	800	195	515	1030	1375	1545	2570	3220	3235
	850	155	400	795	1060	1195	1995	2495	2510
	900	110	285	575	765	860	1435	1800	1805
	950	65	170	345	460	515	855	1070	1080
	1000	40	105	215	285	320	535	670	675

**IMPORTANT: The above ratings are only for reference. Refer to ASME B16.34 for pressure / temperature ratings**

- NOTES:
1. Flanged End Valve ratings are limited to Standard Class only.
  2. Permissible but not recommended for prolonged usage above approximately 800°F.
  3. Shaded ratings exceed those of Edward Valves. Consult your Flowserve sales representative for applications in these ranges.

\* Consult the applicable version of ASME Section III for the correct version of ASME B16.34 to use.

\*\* Pressure - Temperature ratings are from ASME B16.34 "Valves, Flanged, Threaded and Welding Ends". Consult your Flowserve sales representative for Pressure -Temperature ratings of materials not included in this catalog.

## Reference: ASME B16.34 – 2009 Pressure/Temperature Ratings (metric)\*

### Cast Steel\*\* (Gate, Globe & Check Valves)

MATERIAL	TEMP °C	PRESSURE (BAR)							
		Class 150	Class 300	Class 600	Class 800	Class 900	Class 1500	Class 1878	Class 1888
<b>SA216 WCB Standard Class (1) (2) (3)</b>	38	19.6	51.1	102.1	136.2	153.2	255.3	319.6	321.3
	50	19.2	50.1	100.2	133.7	150.4	250.6	313.8	315.4
	100	17.7	46.6	93.2	124.3	139.8	233	291.7	293.3
	150	15.8	45.1	90.2	120.2	135.2	225.4	282.2	283.7
	200	13.8	43.8	87.6	116.8	131.4	219	274.2	275.6
	250	12.1	41.9	83.9	111.8	125.8	209.7	262.5	263.9
	300	10.2	39.8	79.6	106.2	119.5	199.1	249.3	250.6
	325	9.3	38.7	77.4	103.2	116.1	193.6	242.4	243.7
	350	8.4	37.6	75.1	100.2	112.7	187.8	235.1	236.4
	375	7.4	36.4	72.7	97	109.1	181.8	227.7	228.9
	400	6.5	34.7	69.4	92.6	104.2	173.6	217.3	218.5
	425	5.5	28.8	57.5	76.7	86.3	143.8	180.1	181
	450	4.6	23	46	61.3	69	115	144	144.8
	475	3.7	17.4	34.9	46.5	52.3	87.2	109.2	109.7
	500	2.8	11.8	23.5	31.4	35.3	58.8	73.6	74
	538	1.4	5.9	11.8	15.7	17.7	29.5	36.9	37.1
<b>SA216 WCB Special Class (1) (2) (3)</b>	38	19.8	51.7	103.4	137.9	155.1	258.6	323.7	325.5
	50	19.8	51.7	103.4	137.9	155.1	258.6	323.7	325.5
	100	19.8	51.6	103.3	137.7	154.9	258.2	323.3	325
	150	19.6	51	102.1	136.1	153.1	255.2	319.5	321.2
	200	19.4	50.6	101.1	134.8	151.7	252.9	316.6	318.3
	250	19.4	50.5	101.1	134.8	151.6	252.6	316.3	318
	300	19.4	50.5	101.1	134.8	151.6	252.6	316.3	318
	325	19.2	50.1	100.2	133.6	150.3	250.6	313.7	315.4
	350	18.7	48.9	97.8	130.4	146.7	244.6	306.2	307.8
	375	18.1	47.1	94.2	125.6	141.3	235.5	294.8	296.4
	400	16.6	43.4	86.8	115.7	130.2	217	271.7	273.1
	425	13.8	36	71.9	95.9	107.9	179.8	225.1	226.3
	450	11	28.8	57.5	76.7	86.3	143.8	180	181
	475	8.4	21.8	43.6	58.1	65.4	109	136.4	137.2
	500	5.6	14.7	29.4	39.2	44.1	73.5	92	92.5
	538	2.8	7.4	14.8	19.7	22.2	36.9	46.2	46.5

**IMPORTANT:** The above ratings are only for reference. Refer to ASME B16.34 for pressure / temperature ratings.

- NOTES:
1. Flanged End Valve ratings are limited to Standard Class only.
  2. Permissible but not recommended for prolonged usage above approximately 427°C.
  3. Shaded ratings exceed those of Edward Valves. Consult your Flowserve sales representative for applications in these ranges.

\* Consult the applicable version of ASME Section III for the correct version of ASME B16.34 to use.

\*\* Pressure - Temperature ratings are from ASME B16.34 "Valves, Flanged, Threaded and Welding Ends". Consult your Flowserve sales representative for Pressure -Temperature ratings of materials not included in this catalog.

## Reference: ASME B16.34 – 2009 Pressure/Temperature Ratings\*

### Cast Steel\*\* (Gate, Globe & Check Valves)

MATERIAL	TEMP °C	PRESSURE (PSIG)							
		Class 150	Class 300	Class 600	Class 800	Class 900	Class 1500	Class 1878	Class 1888
SA216 WCC Standard Class (1) (2) (3)	100	290	750	1500	2000	2250	3750	4695	4720
	200	260	750	1500	2000	2250	3750	4695	4720
	300	230	730	1455	1940	2185	3640	4560	4585
	400	200	705	1405	1875	2110	3520	4405	4430
	500	170	665	1330	1775	1995	3325	4160	4185
	600	140	605	1210	1615	1815	3025	3785	3805
	650	125	590	1175	1570	1765	2940	3685	3700
	700	110	555	1110	1480	1665	2775	3475	3495
	750	95	505	1015	1350	1520	2535	3175	3195
	800	80	410	825	1100	1235	2055	2575	2590
	850	65	320	640	850	955	1595	1995	2005
	900	50	225	445	595	670	1115	1395	1400
	950	35	135	275	365	410	685	860	865
	1000	20	85	170	225	255	430	540	540
SA216 WCC Special Class (1) (2) (3)	100	290	750	1500	2000	2250	3750	4695	4720
	200	290	750	1500	2000	2250	3750	4695	4720
	300	290	750	1500	2000	2250	3750	4695	4720
	400	290	750	1500	2000	2250	3750	4695	4720
	500	290	750	1500	2000	2250	3750	4695	4720
	600	290	750	1500	2000	2250	3750	4695	4720
	650	290	750	1500	2000	2250	3750	4695	4720
	700	280	715	1425	1900	2140	3565	4465	4485
	750	280	635	1270	1695	1905	3170	3970	3990
	800	255	515	1030	1375	1545	2570	3220	3235
	850	200	400	795	1060	1195	1995	2495	2510
	900	140	280	555	740	835	1395	1745	1755
	950	85	170	345	460	515	855	1070	1080
	1000	55	105	215	285	320	535	670	675

**IMPORTANT:** The above ratings are only for reference. Refer to ASME B16.34 for pressure / temperature ratings.

- NOTES:
1. Flanged End Valve ratings are limited to Standard Class only and terminate at 1000°F.
  2. Permissible but not recommended for prolonged usage above approximately 800°F.
  3. Shaded ratings may require special trim and packing. Consult your Flowserve sales representative for applications in these ranges.

\* Consult the applicable version of ASME Section III for the correct version of ASME B16.34 to use.

\*\* Pressure - Temperature ratings are from ASME B16.34 "Valves, Flanged, Threaded and Welding Ends". Consult your Flowserve sales representative for Pressure -Temperature ratings of materials not included in this catalog.

## Reference: ASME B16.34 – 2009 Pressure/Temperature Ratings (metric)\*

### Cast Steel\*\* (Gate, Globe & Check Valves)

MATERIAL	TEMP °C	PRESSURE (BAR)							
		Class 150	Class 300	Class 600	Class 800	Class 900	Class 1500	Class 1878	Class 1888
<b>SA216 WCC Standard Class (1) (2) (3)</b>	38	19.8	51.7	103.4	137.9	155.1	258.6	323.7	325.5
	50	19.5	51.7	103.4	137.9	155.1	258.6	323.7	325.5
	100	17.7	51.5	103	137.4	154.6	257.6	322.5	324.3
	150	15.8	50.2	100.3	133.8	150.5	250.8	314	315.7
	200	13.8	48.6	97.2	129.6	145.8	243.2	304.5	306.1
	250	12.1	46.3	92.7	123.6	139	231.8	290.2	291.7
	300	10.2	42.9	85.7	114.3	128.6	214.4	268.3	269.8
	325	9.3	41.4	82.6	110.2	124	206.6	258.7	260
	350	8.4	40	80	106.7	120.1	200.1	250.5	251.9
	375	7.4	37.8	75.7	100.9	113.5	189.2	236.9	238.1
	400	6.5	34.7	69.4	92.6	104.2	173.6	217.3	218.5
	425	5.5	28.8	57.5	76.7	86.3	143.8	180.1	181
	450	4.6	23	46	61.3	69	115	144	144.8
	475	3.7	17.1	34.2	45.6	51.3	85.4	106.9	107.5
	500	2.8	11.6	23.2	30.9	34.7	57.9	72.5	72.9
538	1.4	5.9	11.8	15.7	17.7	29.5	36.9	37.1	
<b>SA216 WCC Special Class (1) (2) (3)</b>	38	20	51.7	103.4	137.9	155.1	258.6	323.7	325.5
	50	20	51.7	103.4	137.9	155.1	258.6	323.7	325.5
	100	20	51.7	103.4	137.9	155.1	258.6	323.7	325.5
	150	20	51.7	103.4	137.9	155.1	258.6	323.7	325.5
	200	20	51.7	103.4	137.9	155.1	258.6	323.7	325.5
	250	20	51.7	103.4	137.9	155.1	258.6	323.7	325.5
	300	20	51.7	103.4	137.9	155.1	258.6	323.7	325.5
	325	20	51.7	103.4	137.9	155.1	258.6	323.7	325.5
	350	19.8	51.1	102.2	136.3	153.3	255.5	319.9	321.6
	375	19.3	48.4	96.7	129	145.1	241.9	302.8	304.4
	400	19.3	43.4	86.8	115.7	130.2	217	271.7	273.1
	425	18	36	71.9	95.9	107.9	179.8	225.1	226.3
	450	14.4	28.8	57.5	76.7	86.3	143.8	180	181
	475	10.7	21.4	42.7	57	64.1	106.8	133.7	134.4
	500	7.2	14.5	29	38.6	43.4	72.4	90.7	91.1
538	3.7	7.4	14.8	19.7	22.2	36.9	46.2	46.5	

**IMPORTANT: The above ratings are only for reference. Refer to ASME B16.34 for pressure / temperature ratings.**

- NOTES:
1. Flanged End Valve ratings are limited to Standard Class only and terminate at 538°C.
  2. Permissible but not recommended for prolonged usage above approximately 427°C.
  3. Shaded ratings may require special trim and packing. Consult your Flowserve sales representative for applications in these ranges.

\* Consult the applicable version of ASME Section III for the correct version of ASME B16.34 to use.

\*\* Pressure - Temperature ratings are from ASME B16.34 "Valves, Flanged, Threaded and Welding Ends". Consult your Flowserve sales representative for Pressure -Temperature ratings of materials not included in this catalog.



## Reference: ASME B16.34 – 2009 Pressure/Temperature Ratings\*

### Cast Steel\*\* (Gate, Globe & Check Valves)

MATERIAL	TEMP °C	PRESSURE (PSIG)						
		Class 150	Class 300	Class 600	Class 900	Class 1500	Class 1878	Class 1888
SA217 WC9 Standard Class (1) (2)	100	290	750	1500	2250	3750	4695	4720
	200	260	750	1500	2250	3750	4695	4720
	300	230	730	1455	2185	3640	4560	4585
	400	200	705	1410	2115	3530	4420	4440
	500	170	665	1330	1995	3325	4160	4185
	600	140	605	1210	1815	3025	3785	3805
	650	125	590	1175	1765	2940	3685	3700
	700	110	570	1135	1705	2840	3555	3575
	750	95	530	1065	1595	2660	3330	3345
	800	80	510	1015	1525	2540	3180	3195
	850	65	485	975	1460	2435	3050	3065
	900	50	450	900	1350	2245	2810	2825
	950	35	385	755	1160	1930	2420	2430
	1000	20	265	535	800	1335	1675	1680
	1050	20	175	350	525	875	1095	1100
	1100	20	110	220	330	550	690	690
SA217 WC9 Special Class (1) (2)	100	290	750	1500	2250	3750	4695	4720
	200	290	750	1500	2250	3750	4695	4720
	300	285	740	1480	2220	3695	4625	4650
	400	280	730	1455	2185	3640	4555	4580
	500	280	725	1450	2175	3620	4535	4555
	600	275	720	1440	2165	3605	4515	4540
	650	275	715	1430	2145	3580	4480	4505
	700	270	705	1415	2120	3535	4425	4450
	750	270	705	1415	2120	3535	4425	4450
	800	270	705	1415	2120	3535	4425	4450
	850	260	680	1355	2030	3385	4240	4260
	900	230	600	1200	1800	3000	3755	3775
	950	180	470	945	1415	2360	2955	2970
	1000	130	335	670	1005	1670	2090	2105
	1050	85	220	435	655	1095	1370	1375
	1100	55	135	275	410	685	860	865

**IMPORTANT:** The above ratings are only for reference. Refer to ASME B16.34 for pressure / temperature ratings.

NOTES: 1. Flanged End Valve ratings are limited to Standard Class only and terminate at 1000°F.

2. Shaded ratings may require special trim and packing. Consult your Flowserve sales representative for applications in these ranges.

\* Consult the applicable version of ASME Section III for the correct version of ASME B16.34 to use.

\*\* Pressure - Temperature ratings are from ASME B16.34 "Valves, Flanged, Threaded and Welding Ends". Consult your Flowserve sales representative for Pressure -Temperature ratings of materials not included in this catalog.

## Reference: ASME B16.34 – 2009 Pressure/Temperature Ratings (metric)\*

### Cast Steel\*\* (Gate, Globe & Check Valves)

MATERIAL	TEMP °C	PRESSURE (BAR)						
		Class 150	Class 300	Class 600	Class 900	Class 1500	Class 1878	Class 1888
<b>SA217 WC9</b> <b>Standard Class</b> <b>(1) (2)</b>	38	19.8	51.7	103.4	155.1	258.6	323.7	325.5
	50	19.5	51.7	103.4	155.1	258.6	323.7	325.5
	100	17.7	51.5	103	154.6	257.6	322.5	324.3
	150	15.8	50.3	100.3	150.6	250.8	314.1	315.8
	200	13.8	48.6	97.2	145.8	243.4	304.6	306.3
	250	12.1	46.3	92.7	139	231.8	290.2	291.7
	300	10.2	42.9	85.7	128.6	214.4	268.3	269.8
	325	9.3	41.4	82.6	124	206.6	258.7	260
	350	8.4	40.3	80.4	120.7	201.1	251.8	253.2
	375	7.4	38.9	77.6	116.5	194.1	242.9	244.2
	400	6.5	36.5	73.3	109.8	183.1	229.1	230.4
	425	5.5	35.2	70	105.1	175.1	219.1	220.3
	450	4.6	33.7	67.7	101.4	169	211.6	212.8
	475	3.7	31.7	63.4	95.1	158.2	198.2	199.2
	500	2.8	28.2	56.5	84.7	140.9	176.5	177.4
	538	1.4	18.4	36.9	55.3	92.2	115.4	116.1
	550	1.4	15.6	31.3	46.9	78.2	97.9	98.4
	575	1.4	10.5	21.1	31.6	52.6	65.9	66.2
600	1.4	6.9	13.8	20.7	34.4	43.1	43.3	

**IMPORTANT: The above ratings are only for reference. Refer to ASME B16.34 for pressure / temperature ratings.**

NOTES: 1. Flanged End Valve ratings are limited to Standard Class only and terminate at 538°C.

2. Shaded ratings may require special trim and packing. Consult your Flowserve sales representative for applications in these ranges.

\* Consult the applicable version of ASME Section III for the correct version of ASME B16.34 to use.

\*\* Pressure - Temperature ratings are from ASME B16.34 "Valves, Flanged, Threaded and Welding Ends". Consult your Flowserve sales representative for Pressure - Temperature ratings of materials not included in this catalog.

**Reference: ASME B16.34 – 2009 Pressure/Temperature Ratings (metric)\***

**Cast Steel\*\* (Gate, Globe & Check Valves)**

MATERIAL	TEMP °C	PRESSURE (BAR)						
		Class 150	Class 300	Class 600	Class 900	Class 1500	Class 1878	Class 1888
SA217 WC9 Special Class (1) (2)	38	19.8	51.7	103.4	155.1	258.6	323.7	325.5
	50	19.8	51.7	103.4	155.1	258.6	323.7	325.5
	100	19.8	51.6	103.2	154.9	258.1	323.2	324.9
	150	19.5	51	101.9	152.9	254.8	319	320.7
	200	19.3	50.2	100.4	150.7	251.1	314.4	316.1
	250	19.2	50	100	149.9	249.9	312.9	314.5
	300	19.1	49.8	99.6	149.3	248.9	311.6	313.3
	325	19	49.6	99.2	148.8	248	310.5	312.1
	350	18.9	49.2	98.4	147.6	246	308	309.6
	375	18.7	48.8	97.5	146.3	243.8	305.2	306.9
	400	18.7	48.8	97.5	146.3	243.8	305.2	306.9
	425	18.7	48.8	97.5	146.3	243.8	305.2	306.9
	450	18.1	47.3	94.4	141.4	235.8	295.3	296.8
	475	16.4	42.8	85.5	128.2	213.7	267.6	269
	500	13.7	35.6	71.5	107.1	178.6	223.5	224.7
	538	8.8	23	46.1	69.1	115.2	144.3	145
	550	7.5	19.5	39.1	58.6	97.7	122.3	123
	575	5	13.2	26.3	39.5	65.8	82.4	82.8
600	3.3	8.6	17.2	25.8	43	53.8	54.1	

**IMPORTANT: The above ratings are only for reference. Refer to ASME B16.34 for pressure / temperature ratings.**

NOTES: 1. Flanged End Valve ratings are limited to Standard Class only and terminate at 538°C.

2. Shaded ratings may require special trim and packing. Consult your Flowserve sales representative for applications in these ranges.

\* Consult the applicable version of ASME Section III for the correct version of ASME B16.34 to use.

\*\* Pressure - Temperature ratings are from ASME B16.34 "Valves, Flanged, Threaded and Welding Ends". Consult your Flowserve sales representative for Pressure -Temperature ratings of materials not included in this catalog.

## Reference: ASME B16.34 - 2009 Pressure / Temperature Ratings\*

### Cast Steel \*\* (Gate, Globe & Check Valves)

MATERIAL	TEMP °C	PRESSURE (PSIG)							
		Class 150	Class 300	Class 600	Class 800	Class 900	Class 1500	Class 1878	Class 1888
<b>SA351 CF3</b> <b>Standard Class</b> <b>(1)</b>	100	230	600	1200	1600	1800	3000	3755	3775
	200	195	510	1020	1365	1535	2555	3200	3215
	300	175	455	910	1215	1370	2280	2855	2870
	400	160	420	840	1120	1260	2100	2630	2645
	500	150	395	785	1050	1180	1970	2465	2480
	600	140	370	745	990	1115	1860	2330	2340
	650	125	365	730	975	1095	1825	2285	2295
	700	110	360	720	960	1080	1800	2255	2265
	750	110	355	705	940	1060	1765	2210	2220
	800	80	345	690	920	1035	1730	2165	2175
<b>SA351 CF3</b> <b>Special Class</b> <b>(1)</b>	100	255	670	1340	1785	2010	3350	4195	4215
	200	220	570	1140	1520	1710	2855	3575	3590
	300	195	510	1020	1355	1525	2545	3185	3205
	400	180	470	940	1250	1405	2345	2935	2950
	500	170	440	880	1175	1320	2195	2750	2765
	600	160	415	830	1105	1245	2075	2600	2610
	650	155	405	815	1085	1220	2035	2550	2565
	700	155	400	805	1070	1205	2010	2515	2530
	750	150	395	790	1050	1180	1970	2465	2480
800	150	385	770	1025	1155	1930	2415	2430	

**IMPORTANT: The above ratings are only for reference. Refer to ASME B16.34 for pressure / temperature ratings.**

NOTES: 1. Flanged End Valve ratings are limited to Standard Class only.

\* Consult the applicable version of ASME Section III for the correct version of ASME B16.34 to use.

\*\* Pressure - Temperature ratings are from ASME B16.34 "Valves, Flanged, Threaded and Welding Ends". Consult your Flowserve sales representative for Pressure -Temperature ratings of materials not included in this catalog.

## Reference: ASME B16.34 – 2009 Pressure/Temperature Ratings (metric)\*

### Cast Steel \*\* (Gate, Globe & Check Valves)

MATERIAL	TEMP °C	PRESSURE (BAR)							
		Class 150	Class 300	Class 600	Class 800	Class 900	Class 1500	Class 1878	Class 1888
<b>SA351 CF3 Standard Class (1)</b>	38	15.9	41.4	82.7	110.3	124.1	206.8	258.9	260.3
	50	15.3	40	80	106.7	120.1	200.1	250.5	251.9
	100	13.3	34.8	69.6	92.8	104.4	173.9	217.7	218.9
	150	12	31.4	62.8	83.7	94.2	157	196.5	197.6
	200	11.2	29.2	58.3	77.8	87.5	145.8	182.5	183.5
	250	10.5	27.5	54.9	73.2	82.4	137.3	171.9	172.8
	300	10	26.1	52.1	69.5	78.2	130.3	163.1	164
	325	9.3	25.5	51	67.9	76.4	127.4	159.5	160.3
	350	8.4	25.1	50.1	66.8	75.2	125.4	157	157.8
	375	7.4	24.8	49.5	66	74.3	123.8	155	155.8
	400	6.5	24.3	48.6	64.8	72.9	121.5	152.1	152.9
	425	5.5	23.9	47.7	63.6	71.6	119.3	149.4	150.1
<b>SA351 CF3 Special Class (1)</b>	38	17.7	46.2	92.3	123.1	138.5	230.9	289.1	290.6
	50	17.1	44.7	89.3	119.1	134	223.3	279.6	281.1
	100	14.9	38.8	77.7	103.6	116.5	194.1	243.1	244.3
	150	13.4	35	70.1	93.4	105.1	175.2	219.3	220.5
	200	12.5	32.5	65.1	86.8	97.6	162.7	203.7	204.8
	250	11.8	30.7	61.3	81.8	92	153.3	191.9	192.9
	300	11.2	29.1	58.2	77.6	87.3	145.5	182.1	183.1
	325	10.9	28.4	56.9	75.8	85.3	142.2	178	179
	350	10.7	28	56	74.6	83.9	139.9	175.2	176.1
	375	10.6	27.6	55.2	73.7	82.9	138.1	172.9	173.8
	400	10.4	27.1	54.3	72.4	81.4	135.6	169.8	170.7
	425	10.2	26.6	53.3	71	79.9	133.1	166.7	167.6

**IMPORTANT: The above ratings are only for reference. Refer to ASME B16.34 for pressure / temperature ratings.**

NOTES: 1. Flanged End Valve ratings are limited to Standard Class only.

\* Consult the applicable version of ASME Section III for the correct version of ASME B16.34 to use.

\*\* Pressure - Temperature ratings are from ASME B16.34 "Valves, Flanged, Threaded and Welding Ends". Consult your Flowserve sales representative for Pressure -Temperature ratings of materials not included in this catalog.



## Reference: ASME B16.34 – 2009 Pressure/Temperature Ratings\*

### Cast Steel\*\* (Gate, Globe & Check Valves)

MATERIAL	TEMP. °C	PRESSURE (PSIG)							
		Class 150	Class 300	Class 600	Class 800	Class 900	Class 1500	Class 1878	Class 1888
SA351 CF8 Standard Class (1)	100	275	720	1440	1920	2160	3600	4505	4530
	200	230	600	1200	1600	1800	3000	3755	3775
	300	205	540	1075	1435	1615	2690	3365	3385
	400	190	495	995	1325	1490	2485	3110	3125
	500	170	465	930	1240	1395	2330	2915	2930
	600	140	440	885	1180	1325	2210	2765	2780
	650	125	430	865	1150	1295	2160	2705	2720
	700	110	420	845	1125	1265	2110	2645	2655
	750	95	415	825	1100	1240	2065	2585	2600
	800	80	405	810	1080	1215	2030	2540	2555
	850	65	395	790	1055	1190	1980	2480	2490
	900	50	390	780	1035	1165	1945	2435	2445
	950	35	380	765	1020	1145	1910	2390	2405
	1000	20	355	710	945	1065	1770	2215	2230
	1050	20	325	650	865	975	1630	2040	2050
	1100	20	255	515	685	770	1285	1610	1620
	1150	20	205	410	545	615	1030	1290	1295
	1200	20	165	330	440	495	825	1030	1035
	1250	20	135	265	355	400	670	840	845
	1300	20	115	225	300	340	565	710	710
1350	20	95	185	250	280	465	580	585	
1400	20	75	150	200	225	380	475	475	
1450	20	60	115	155	175	290	365	365	
1500	15	40	85	110	125	205	260	260	

**IMPORTANT: The above ratings are only for reference. Refer to ASME B16.34 for pressure/temperature ratings.**

NOTES: 1. Flanged End Valve ratings are limited to Standard Class only and terminate at 1000°F.

2. Shaded ratings may require special trim and packing. Consult your Flowserve sales representative for applications in these ranges.

\* Consult the applicable version of ASME Section III for the correct version of ASME B16.34 to use.

\*\* Pressure - Temperature ratings are from ASME B16.34 "Valves, Flanged, Threaded and Welding Ends". Consult your Flowserve sales representative for Pressure -Temperature ratings of materials not included in this catalog.

## Reference: ASME B16.34 – 2009 Pressure/Temperature Ratings\*

### Cast Steel\*\* (Gate, Globe & Check Valves)

MATERIAL	TEMP. °C	PRESSURE (PSIG)							
		Class 150	Class 300	Class 600	Class 800	Class 900	Class 1500	Class 1878	Class 1888
SA351 CF8 Special Class (1)	100	290	750	1500	2000	2250	3750	4695	4720
	200	255	670	1340	1785	2010	3350	4195	4215
	300	230	600	1200	1600	1800	3000	3755	3775
	400	215	555	1110	1480	1665	2770	3470	3490
	500	200	520	1040	1385	1560	2600	3255	3270
	600	190	495	985	1315	1480	2465	3085	3100
	650	185	480	965	1285	1445	2410	3020	3035
	700	180	470	945	1260	1415	2355	2950	2965
	750	175	460	920	1225	1380	2305	2885	2900
	800	175	455	905	1210	1360	2265	2835	2850
	850	170	440	885	1180	1325	2210	2770	2780
	900	165	435	870	1155	1300	2170	2715	2730
	950	165	425	850	1135	1280	2130	2665	2680
	1000	160	415	830	1105	1245	2075	2600	2610
	1050	155	405	815	1085	1220	2035	2550	2565
	1100	125	320	645	860	965	1605	2010	2020
	1150	100	255	515	685	770	1285	1610	1620
	1200	80	205	410	545	615	1030	1290	1295
	1250	65	165	335	445	500	835	1045	1050
	1300	55	140	285	380	425	705	885	890
1350	45	115	230	305	345	580	725	730	
1400	35	95	190	255	285	470	590	590	
1450	30	75	145	195	220	365	460	460	
1500	20	50	105	140	155	260	325	325	

**IMPORTANT:** The above ratings are only for reference. Refer to ASME B16.34 for pressure/temperature ratings.

NOTES: 1. Flanged End Valve ratings are limited to Standard Class only and terminate at 1000°F.

2. Shaded ratings may require special trim and packing. Consult your Flowserve sales representative for applications in these ranges.

\* Consult the applicable version of ASME Section III for the correct version of ASME B16.34 to use.

\*\* Pressure - Temperature ratings are from ASME B16.34 "Valves, Flanged, Threaded and Welding Ends". Consult your Flowserve sales representative for Pressure -Temperature ratings of materials not included in this catalog.

## Reference: ASME B16.34 – 2009 Pressure/Temperature Ratings (metric)\*

### Cast Steel\*\* (Gate, Globe & Check Valves)

MATERIAL	TEMP. °C	PRESSURE (BAR)							
		Class 150	Class 300	Class 600	Class 800	Class 900	Class 1500	Class 1878	Class 1888
<b>SA351 CF8 Standard Class (1) (2)</b>	38	19	49.6	99.3	132.4	148.9	248.2	310.8	312.4
	50	18.3	47.8	95.6	127.5	143.5	239.1	299.4	300.9
	100	15.7	40.9	81.7	109	122.6	204.3	255.7	257.1
	150	14.2	37	74	98.7	111	185	231.6	232.9
	200	13.2	34.5	69	91.9	103.4	172.4	215.8	217
	250	12.1	32.5	65	86.7	97.5	162.4	203.3	204.4
	300	10.2	30.9	61.8	82.4	92.7	154.6	193.5	194.6
	325	9.3	30.2	60.4	80.6	90.7	151.1	189.2	190.2
	350	8.4	29.6	59.3	79	88.9	148.1	185.4	186.4
	375	7.4	29	58.1	77.4	87.1	145.2	181.8	182.7
	400	6.5	28.4	56.9	75.8	85.3	142.2	178	179
	425	5.5	28	56	74.7	84	140	175.3	176.2
	450	4.6	27.4	54.8	73.1	82.2	137	171.5	172.5
	475	3.7	26.9	53.9	71.8	80.8	134.7	168.6	169.5
	500	2.8	26.5	53	70.7	79.5	132.4	165.8	166.7
	538	1.4	24.4	48.9	65.2	73.3	122.1	152.9	153.7
	550	1.4	23.6	47.1	62.8	70.7	117.8	147.5	148.3
	575	1.4	20.8	41.7	55.6	62.5	104.2	130.5	131.2
	600	1.4	16.9	33.8	45	50.6	84.4	105.7	106.2
	625	1.4	13.8	27.6	36.8	41.4	68.9	86.3	86.7
650	1.4	11.3	22.5	30	33.8	56.3	70.5	70.9	
675	1.4	9.3	18.7	24.9	28	46.7	58.5	58.8	
700	1.4	8	16.1	21.4	24.1	40.1	50.2	50.5	
725	1.4	6.8	13.5	18	20.3	33.8	42.3	42.5	
750	1.4	5.8	11.6	15.4	17.3	28.9	36.2	36.3	
775	1.4	4.6	9	12.1	13.7	22.8	28.5	28.7	
800	1.2	3.5	7	9.3	10.5	17.4	21.9	22	
816	1	2.8	5.9	7.7	8.6	14.1	17.8	17.9	

**IMPORTANT: The above ratings are only for reference. Refer to ASME B16.34 for pressure/temperature ratings.**

NOTES: 1. Flanged End Valve ratings are limited to Standard Class only and terminate at 538°C.

2. Shaded ratings may require special trim and packing. Consult your Flowserve sales representative for applications in these ranges.

\* Consult the applicable version of ASME Section III for the correct version of ASME B16.34 to use.

\*\* Pressure - Temperature ratings are from ASME B16.34 "Valves, Flanged, Threaded and Welding Ends". Consult your Flowserve sales representative for Pressure -Temperature ratings of materials not included in this catalog.



## Reference: ASME B16.34 – 2009 Pressure/Temperature Ratings (metric)\*

### Cast Steel\*\* (Gate, Globe & Check Valves)

MATERIAL	TEMP. °C	PRESSURE (BAR)							
		Class 150	Class 300	Class 600	Class 800	Class 900	Class 1500	Class 1878	Class 1888
SA351 CF8 Special Class (1) (2)	38	19.8	51.7	103.4	137.9	155.1	258.6	323.7	325.5
	50	19.4	50.5	101	134.7	151.5	252.5	316.1	317.8
	100	17.5	45.6	91.2	121.6	136.8	228	285.5	287
	150	15.8	41.3	82.6	110.1	123.9	206.5	258.6	259.9
	200	14.8	38.5	77	102.6	115.4	192.4	240.9	242.2
	250	13.9	36.3	72.5	96.7	108.8	181.3	227	228.2
	300	13.2	34.5	69	92	103.5	172.5	216	217.1
	325	12.9	33.7	67.5	90	101.2	168.7	211.2	212.3
	350	12.7	33.1	66.1	88.2	99.2	165.3	207	208.1
	375	12.4	32.4	64.8	86.4	97.2	162	202.8	203.9
	400	12.2	31.7	63.5	84.6	95.2	158.7	198.7	199.8
	425	12	31.2	62.5	83.3	93.7	156.2	195.6	196.6
	450	11.7	30.6	61.2	81.6	91.8	153	191.5	192.5
	475	11.5	30.1	60.1	80.2	90.2	150.3	188.2	189.2
	500	11.3	29.6	59.1	78.8	88.7	147.8	185.1	186.1
	538	11	28.6	57.3	76.4	85.9	143.1	179.2	180.1
	550	10.9	28.4	56.8	75.7	85.1	141.9	177.7	178.6
	575	10	26.1	52.1	69.5	78.2	130.3	163.1	164
	600	8.1	21.1	42.2	56.3	63.3	105.5	132.1	132.8
	625	6.6	17.2	34.5	46	51.7	86.2	107.9	108.5
	650	5.4	14.1	28.2	37.5	42.2	70.4	88.1	88.6
	675	4.5	11.7	23.4	31.2	35.1	58.4	73.1	73.5
	700	4.1	10.7	21.3	28.4	32	53.3	66.8	67.1
	725	3.5	9.2	18.5	24.6	27.7	46.2	57.8	58.2
750	2.8	7.4	14.8	19.7	22.1	36.7	46	46.2	
775	2.2	5.8	11.4	15.3	17.2	28.5	35.7	35.9	
800	1.8	4.4	8.8	11.7	13.2	22	27.5	27.7	
816	1.4	3.4	7.2	9.5	10.7	17.9	22.3	22.4	

**IMPORTANT:** The above ratings are only for reference. Refer to ASME B16.34 for pressure/temperature ratings.

- NOTES: 1. Flanged End Valve ratings are limited to Standard Class only and terminate at 538°C.  
 2. Shaded ratings may require special trim and packing. Consult your Flowserve sales representative for applications in these ranges.

\* Consult the applicable version of ASME Section III for the correct version of ASME B16.34 to use.

\*\* Pressure - Temperature ratings are from ASME B16.34 "Valves, Flanged, Threaded and Welding Ends". Consult your Flowserve sales representative for Pressure -Temperature ratings of materials not included in this catalog.



## Reference: ASME B16.34 – 2009 Pressure/Temperature Ratings\*

### Cast Steel\*\* (Gate, Globe & Check Valves)

MATERIAL	TEMP. °F	PRESSURE (PSIG)							
		Class 150	Class 300	Class 600	Class 800	Class 900	Class 1500	Class 1878	Class 1888
<b>SA351 CF3M Standard Class (1)</b>	100	230	600	1200	1600	1800	3000	3755	3775
	200	195	510	1020	1365	1535	2555	3200	3215
	300	175	455	910	1215	1370	2280	2855	2870
	400	160	420	840	1120	1260	2100	2630	2645
	500	150	395	785	1050	1180	1970	2465	2480
	600	140	370	745	990	1115	1860	2330	2340
	650	125	365	730	975	1095	1825	2285	2295
	700	110	360	720	960	1080	1800	2255	2265
	750	110	355	705	940	1060	1765	2210	2220
	800	80	345	690	920	1035	1730	2165	2175
<b>SA351 CF3M Special Class (1)</b>	100	255	670	1340	1785	2010	3350	4195	4215
	200	220	570	1140	1520	1710	2855	3575	3590
	300	195	510	1020	1355	1525	2545	3185	3205
	400	180	470	940	1250	1405	2345	2935	2950
	500	170	440	880	1175	1320	2195	2750	2765
	600	160	415	830	1105	1245	2075	2600	2610
	650	155	405	815	1085	1220	2035	2550	2565
	700	155	400	805	1070	1205	2010	2515	2530
	750	150	395	790	1050	1180	1970	2465	2480
800	150	385	770	1025	1155	1930	2415	2430	

**IMPORTANT: The above ratings are only for reference. Refer to ASME B16.34 for pressure/temperature ratings.**

NOTES: 1. Flanged End Valve ratings are limited to Standard Class only.

\* Consult the applicable version of ASME Section III for the correct version of ASME B16.34 to use.

\*\* Pressure - Temperature ratings are from ASME B16.34 "Valves, Flanged, Threaded and Welding Ends". Consult your Flowserve sales representative for Pressure -Temperature ratings of materials not included in this catalog.

**Reference: ASME B16.34 – 2009 Pressure/Temperature Ratings (metric)\***

**Cast Steel\*\* (Gate, Globe & Check Valves)**

MATERIAL	TEMP. °F	PRESSURE (BAR)							
		Class 150	Class 300	Class 600	Class 800	Class 900	Class 1500	Class 1878	Class 1888
<b>SA351 CF3 Standard Class (1)</b>	38	15.9	41.4	82.7	110.3	124.1	206.8	258.9	260.3
	50	15.3	40	80	106.7	120.1	200.1	250.5	251.9
	100	13.3	34.8	69.6	92.8	104.4	173.9	217.7	218.9
	150	12	31.4	62.8	83.7	94.2	157	196.5	197.6
	200	11.2	29.2	58.3	77.8	87.5	145.8	182.5	183.5
	250	10.5	27.5	54.9	73.2	82.4	137.3	171.9	172.8
	300	10	26.1	52.1	69.5	78.2	130.3	163.1	164
	325	9.3	25.5	51	67.9	76.4	127.4	159.5	160.3
	350	8.4	25.1	50.1	66.8	75.2	125.4	157	157.8
	375	7.4	24.8	49.5	66	74.3	123.8	155	155.8
	400	6.5	24.3	48.6	64.8	72.9	121.5	152.1	152.9
	425	5.5	23.9	47.7	63.6	71.6	119.3	149.4	150.1
<b>SA351 CF3 Special Class (1)</b>	38	17.7	46.2	92.3	123.1	138.5	230.9	289.1	290.6
	50	17.1	44.7	89.3	119.1	134	223.3	279.6	281.1
	100	14.9	38.8	77.7	103.6	116.5	194.1	243.1	244.3
	150	13.4	35	70.1	93.4	105.1	175.2	219.3	220.5
	200	12.5	32.5	65.1	86.8	97.6	162.7	203.7	204.8
	250	11.8	30.7	61.3	81.8	92	153.3	191.9	192.9
	300	11.2	29.1	58.2	77.6	87.3	145.5	182.1	183.1
	325	10.9	28.4	56.9	75.8	85.3	142.2	178	179
	350	10.7	28	56	74.6	83.9	139.9	175.2	176.1
	375	10.6	27.6	55.2	73.7	82.9	138.1	172.9	173.8
	400	10.4	27.1	54.3	72.4	81.4	135.6	169.8	170.7
	425	10.2	26.6	53.3	71	79.9	133.1	166.7	167.6

**IMPORTANT: The above ratings are only for reference. Refer to ASME B16.34 for pressure/temperature ratings.**

NOTES: 1. Flanged End Valve ratings are limited to Standard Class only.

\* Consult the applicable version of ASME Section III for the correct version of ASME B16.34 to use.

\*\* Pressure - Temperature ratings are from ASME B16.34 "Valves, Flanged, Threaded and Welding Ends". Consult your Flowserve sales representative for Pressure -Temperature ratings of materials not included in this catalog.



## Reference: ASME B16.34 – 2009 Pressure/Temperature Ratings\*

### Cast Steel\*\* (Gate, Globe & Check Valves)

RATING	TEMP. °F	PRESSURE (PSIG)							
		Class 150	Class 300	Class 600	Class 800	Class 900	Class 1500	Class 1878	Class 1888
SA351 CF8M Standard Class (1)	100	275	720	1440	1920	2160	3600	4505	4530
	200	235	620	1240	1655	1860	3095	3875	3895
	300	215	560	1120	1495	1680	2795	3500	3520
	400	195	515	1025	1370	1540	2570	3215	3235
	500	170	480	955	1275	1435	2390	2990	3005
	600	140	450	900	1205	1355	2255	2825	2840
	650	125	440	885	1180	1325	2210	2765	2780
	700	110	435	870	1160	1305	2170	2720	2735
	750	95	425	855	1140	1280	2135	2675	2690
	800	80	420	845	1125	1265	2110	2645	2655
	850	65	420	835	1115	1255	2090	2615	2630
	900	50	415	830	1105	1245	2075	2600	2610
	950	35	385	775	1030	1160	1930	2420	2430
	1000	20	365	725	970	1090	1820	2275	2290
	1050	20	360	720	960	1080	1800	2255	2265
	1100	20	305	610	815	915	1525	1910	1920
	1150	20	235	475	630	710	1185	1480	1490
	1200	20	185	370	495	555	925	1160	1165
	1250	20	145	295	390	440	735	920	925
	1300	20	115	235	310	350	585	730	735
1350	20	95	190	255	290	480	600	605	
1400	20	75	150	200	225	380	475	475	
1450	20	60	115	155	175	290	365	365	
1500	15	40	85	110	125	205	260	260	

**IMPORTANT: The above ratings are only for reference. Refer to ASME B16.34 for pressure / temperature ratings.**

NOTES: 1. Flanged End Valve ratings are limited to Standard Class only and terminate at 1000°F.

2. Shaded ratings may require special trim and packing. Consult your Flowserve sales representative for applications in these ranges.

\* Consult the applicable version of ASME Section III for the correct version of ASME B16.34 to use.

\*\* Pressure - Temperature ratings are from ASME B16.34 "Valves, Flanged, Threaded and Welding Ends". Consult your Flowserve sales representative for Pressure -Temperature ratings of materials not included in this catalog.

## Reference: ASME B16.34 – 2009 Pressure/Temperature Ratings\*

### Cast Steel\*\* (Gate, Globe & Check Valves)

MATERIAL	TEMP. °C	PRESSURE (PSIG)							
		Class 150	Class 300	Class 600	Class 800	Class 900	Class 1500	Class 1875	Class 1888
SA351 CF8M Special Class (1)	100	290	750	1500	2000	2250	3750	4695	4720
	200	265	690	1380	1845	2075	3455	4325	4350
	300	240	625	1250	1665	1870	3120	3905	3925
	400	220	575	1145	1530	1720	2865	3585	3605
	500	205	535	1065	1420	1600	2665	3335	3355
	600	195	505	1005	1340	1510	2520	3155	3170
	650	190	495	985	1315	1480	2465	3085	3100
	700	185	485	970	1295	1455	2425	3035	3050
	750	185	475	955	1270	1430	2385	2985	3000
	800	180	470	945	1260	1415	2355	2950	2965
	850	180	465	930	1245	1400	2330	2920	2935
	900	180	465	925	1235	1390	2315	2900	2915
	950	175	460	915	1220	1375	2290	2865	2880
	1000	160	420	840	1120	1260	2105	2635	2650
	1050	160	420	840	1120	1260	2105	2635	2650
	1100	145	380	765	1020	1145	1905	2385	2400
	1150	115	295	590	785	885	1480	1850	1860
	1200	90	230	465	620	695	1155	1450	1455
	1250	70	185	370	495	555	920	1150	1160
	1300	55	145	290	385	435	730	915	920
1350	45	120	240	320	360	600	750	755	
1400	35	95	190	255	285	470	590	590	
1450	30	75	145	195	220	365	455	460	
1500	20	50	105	140	155	260	325	325	

**IMPORTANT: The above ratings are only for reference. Refer to ASME B16.34 for pressure / temperature ratings.**

NOTES: 1. Flanged End Valve ratings are limited to Standard Class only and terminate at 1000°F.  
 2. Shaded ratings may require special trim and packing. Consult your Flowserve sales representative for applications in these ranges.

\* Consult the applicable version of ASME Section III for the correct version of ASME B16.34 to use.

\*\* Pressure - Temperature ratings are from ASME B16.34 "Valves, Flanged, Threaded and Welding Ends". Consult your Flowserve sales representative for Pressure - Temperature ratings of materials not included in this catalog.



**Reference: ASME B16.34 – 2009 Pressure/Temperature Ratings (metric)\***

**Cast Steel\*\* (Gate, Globe & Check Valves)**

MATERIAL	TEMP. °C	PRESSURE (BAR)							
		Class 150	Class 300	Class 600	Class 800	Class 900	Class 1500	Class 1878	Class 1888
SA351 CF8M Standard Class (1) (2)	38	19	49.6	99.3	132.4	148.9	248.2	310.8	312.4
	50	18.4	48.1	96.2	128.3	144.3	240.6	301.2	302.8
	100	16.2	42.2	84.4	112.5	126.6	211	264.1	265.6
	150	14.8	38.5	77	102.7	115.5	192.5	241	242.3
	200	13.7	35.7	71.3	95.1	107	178.3	223.2	224.4
	250	12.1	33.4	66.8	89	100.1	166.9	208.9	210
	300	10.2	31.6	63.2	84.3	94.9	158.1	197.9	199
	325	9.3	30.9	61.8	82.4	92.7	154.4	193.3	194.4
	350	8.4	30.3	60.7	80.9	91	151.6	189.8	190.8
	375	7.4	29.9	59.8	79.7	89.6	149.4	187	188
	400	6.5	29.4	58.9	78.5	88.3	147.2	184.3	185.3
	425	5.5	29.1	58.3	77.7	87.4	145.7	182.4	183.4
	450	4.6	28.8	57.7	76.9	86.5	144.2	180.6	181.5
	475	3.7	28.7	57.3	76.4	86	143.4	179.5	180.5
	500	2.8	28.2	56.5	75.3	84.7	140.9	176.5	177.4
	538	1.4	25.2	50	66.8	75.2	125.5	157	157.9
	550	1.4	25	49.8	66.5	74.8	124.9	156.3	157.1
	575	1.4	24	47.9	63.8	71.8	119.7	149.9	150.7
	600	1.4	19.9	39.8	53.1	59.7	99.5	124.6	125.3
	625	1.4	15.8	31.6	42.1	47.4	79.1	99	99.5
	650	1.4	12.7	25.3	33.8	38	63.3	79.3	79.7
	675	1.4	10.3	20.6	27.5	31	51.6	64.6	64.9
	700	1.4	8.4	16.8	22.3	25.1	41.9	52.4	52.7
725	1.4	7	14	18.7	21	34.9	43.7	43.9	
750	1.4	5.9	11.7	15.6	17.6	29.3	36.7	36.9	
775	1.4	4.6	9	12.1	13.7	22.8	28.5	28.7	
800	1.2	3.5	7	9.3	10.5	17.4	21.9	22	
816	1	2.8	5.9	7.7	8.6	14.1	17.8	17.9	

**IMPORTANT: The above ratings are only for reference. Refer to ASME B16.34 for pressure/temperature ratings.**

- NOTES: 1. Flanged End Valve ratings are limited to Standard Class only and terminate at 538°C.  
 2. Shaded ratings may require special trim and packing. Consult your Flowserve sales representative for applications in these ranges.

\* Consult the applicable version of ASME Section III for the correct version of ASME B16.34 to use.

\*\* Pressure - Temperature ratings are from ASME B16.34 “Valves, Flanged, Threaded and Welding Ends”. Consult your Flowserve sales representative for Pressure -Temperature ratings of materials not included in this catalog.

**Reference: ASME B16.34 – 2009 Pressure/Temperature Ratings (metric)\***

**Cast Steel\*\* (Gate, Globe & Check Valves)**

MATERIAL	TEMP. °C	PRESSURE (BAR)							
		Class 150	Class 300	Class 600	Class 800	Class 900	Class 1500	Class 1878	Class 1888
SA351 CF8M Special Class (1) (2)	38	19.8	51.7	103.4	137.9	155.1	258.6	323.7	325.5
	50	19.5	50.8	101.6	135.5	152.5	254.1	318.1	319.8
	100	18.1	47.1	94.2	125.6	141.3	235.5	294.8	296.4
	150	16.5	43	85.9	114.6	128.9	214.8	268.9	270.4
	200	15.3	39.8	79.6	106.1	119.4	199	249.2	250.5
	250	14.3	37.3	74.5	99.4	111.8	186.3	233.2	234.5
	300	13.5	35.3	70.6	94.1	105.9	176.4	220.9	222.1
	325	13.2	34.5	68.9	91.9	103.4	172.3	215.7	216.9
	350	13	33.8	67.7	90.2	101.5	169.2	211.9	213
	375	12.8	33.3	66.7	88.9	100	166.7	208.7	209.8
	400	12.6	32.9	65.7	87.6	98.6	164.3	205.7	206.8
	425	12.5	32.5	65.1	86.8	97.6	162.6	203.6	204.7
	450	12.3	32.2	64.4	85.9	96.6	161	201.6	202.6
	475	12.3	32	64	85.3	96	160	200.3	201.4
	500	12.2	31.7	63.4	84.5	95.1	158.6	198.6	199.6
	538	11	29	57.9	77.2	86.9	145.1	181.6	182.6
	550	11	29	57.9	77.2	86.9	145.1	181.6	182.6
	575	10.9	28.6	57.1	76.2	85.7	143	179	180
	600	9.5	24.9	49.8	66.3	74.6	124.4	155.7	156.6
	625	7.6	19.8	39.5	52.7	59.3	98.8	123.7	124.4
650	6.1	15.8	31.7	42.2	47.5	79.1	99.1	99.6	
675	4.9	12.9	25.8	34.4	38.7	64.5	80.8	81.2	
700	4.4	11.4	22.8	30.5	34.3	57.1	71.5	71.9	
725	3.7	9.5	19.1	25.4	28.6	47.7	59.7	60	
750	2.8	7.4	14.8	19.7	22.1	36.7	46	46.2	
775	2.2	5.8	11.4	15.3	17.2	28.5	35.7	35.9	
800	1.8	4.4	8.8	11.7	13.2	22	27.5	27.7	
816	1.4	3.4	7.2	9.5	10.7	17.9	22.3	22.4	

**IMPORTANT: The above ratings are only for reference. Refer to ASME B16.34 for pressure/temperature ratings.**

- NOTES: 1. Flanged End Valve ratings are limited to Standard Class only and terminate at 538°C.  
 2. Shaded ratings may require special trim and packing. Consult your Flowserve sales representative for applications in these ranges.

\* Consult the applicable version of ASME Section III for the correct version of ASME B16.34 to use.

\*\* Pressure - Temperature ratings are from ASME B16.34 "Valves, Flanged, Threaded and Welding Ends". Consult your Flowserve sales representative for Pressure -Temperature ratings of materials not included in this catalog.

## Reference: ASME B16.34 – 2009 Pressure/Temperature Ratings\*

### Forged Steel Univalves

MATERIAL	TEMP. °C	PRESSURE (PSIG)			
		Class 600	Class 1500 (1)	Class 1690	Class 2500
<b>SA105 Standard Class (2) (4)</b>	100	1480	3705	4175	6170
	200	1360	3395	3825	5655
	300	1310	3270	3685	5450
	400	1265	3170	3570	5280
	500	1205	3015	3395	5025
	600	1135	2840	3200	4730
	650	1100	2745	3095	4575
	700	1060	2665	3000	4425
	750	1015	2535	2855	4230
	800	825	2055	2315	3430
	850	640	1595	1795	2655
	900	460	1150	1295	1915
	950	275	685	770	1145
	1000	170	430	485	715
	<b>SA105 Special Class (3) (4)</b>	100	1500	3750	4225
200		1500	3750	4225	6250
300		1480	3700	4170	6170
400		1465	3665	4130	6105
500		1465	3665	4130	6105
600		1465	3665	4130	6105
650		1430	3575	4030	5960
700		1380	3455	3895	5760
750		1270	3170	3570	5285
800		1030	2570	2895	4285
850		795	1995	2245	3320
900		575	1435	1615	2395
950		345	855	965	1430
1000		215	535	605	895

**IMPORTANT: The above ratings are only for reference. Refer to ASME B16.34 for pressure/temperature ratings.**

- NOTES:
1. Standard Class: Flanged Ends Sizes ½ through 2-½, only.
  2. Limited Class: Sizes 2-½ and smaller, butt weld and socket weld ends.  
Limited Class: Threaded ends limited to Sizes 1 and smaller, 1000°F maximum and pressure class 2500 maximum.
  3. Special Class: Sizes 3 and 4, Butt weld ends only.
  4. Permissible but not recommended for prolonged usage above approximately 800°F.
  5. Shaded ratings exceed those of Edward Valves. Consult your Flowserve sales representative for applications in these ranges.

\* Consult the applicable version of ASME Section III for the correct version of ASME B16.34 to use.

\*\* Pressure - Temperature ratings are from ASME B16.34 "Valves, Flanged, Threaded and Welding Ends". Consult your Flowserve sales representative for Pressure - Temperature ratings of materials not included in this catalog.



## Reference: ASME B16.34 – 2009 Pressure/Temperature Ratings\*

### Forged Steel Univalves

MATERIAL	TEMP. °C	PRESSURE (PSIG)			
		Class 600	Class 1500 (1)	Class 1690	Class 2500
SA105 Limited Class (2) (4)	100	1500	3750	4225	6250
	200	1500	3750	4225	6250
	300	1480	3700	4170	6170
	400	1465	3665	4130	6105
	500	1465	3665	4130	6105
	600	1465	3665	4130	6105
	650	1430	3575	4030	5960
	700	1380	3455	3895	5760
	750	1270	3170	3570	5285
	800	1030	2570	2895	4285
	850	795	1995	2245	3320
	900	575	1435	1615	2395
	950	350	875	990	1485
	1000	220	570	650	1000

**IMPORTANT:** The above ratings are only for reference. Refer to ASME B16.34 for pressure/temperature ratings.

- NOTES:
1. Standard Class: Flanged Ends Sizes ½ through 2-½, only.
  2. Limited Class: Sizes 2-½ and smaller, butt weld and socket weld ends.  
Limited Class: Threaded ends limited to Sizes 1 and smaller, 1000°F maximum and pressure class 2500 maximum.
  3. Special Class: Sizes 3 and 4, Butt weld ends only.
  4. Permissible but not recommended for prolonged usage above approximately 800°F.
  5. Shaded ratings exceed those of Edward Valves. Consult your Flowserve sales representative for applications in these ranges.

\* Consult the applicable version of ASME Section III for the correct version of ASME B16.34 to use.

\*\* Pressure - Temperature ratings are from ASME B16.34 "Valves, Flanged, Threaded and Welding Ends". Consult your Flowserve sales representative for Pressure -Temperature ratings of materials not included in this catalog.

## Reference: ASME B16.34 – 2009 Pressure/Temperature Ratings (metric)\*

### Forged Steel Univalves

MATERIAL	TEMP. °C	PRESSURE (BAR)			
		Class 600	Class 1500 (1)	Class 1690	Class 2500
<b>SA105 Standard Class (2) (4)</b>	38	102.1	255.3	287.6	425.5
	50	100.2	250.6	282.3	417.7
	100	93.2	233	262.5	388.3
	150	90.2	225.4	253.9	375.6
	200	87.6	219	246.7	365
	250	83.9	209.7	236.3	349.5
	300	79.6	199.1	224.3	331.8
	325	77.4	193.6	218.1	322.6
	350	75.1	187.8	211.6	313
	375	72.7	181.8	204.8	303.1
	400	69.4	173.6	195.6	289.3
	425	57.5	143.8	162	239.7
	450	46	115	129.6	191.7
	475	34.9	87.2	98.2	145.3
	500	23.5	58.8	66.2	97.9
	538	11.8	29.5	33.2	49.2
<b>SA105 Special Class (3) (4)</b>	38	103.4	258.6	291.3	430.9
	50	103.4	258.6	291.3	430.9
	100	103.3	258.2	290.9	430.3
	150	102.1	255.2	287.5	425.3
	200	101.1	252.9	284.9	421.4
	250	101.1	252.6	284.6	421.1
	300	101.1	252.6	284.6	421.1
	325	100.2	250.6	282.3	417.6
	350	97.8	244.6	275.6	407.6
	375	94.2	235.5	265.3	392.5
	400	86.8	217	244.5	361.7
	425	71.9	179.8	202.6	299.6
	450	57.5	143.8	162	239.6
	475	43.6	109	122.8	181.6
	500	29.4	73.5	82.8	122.4
	538	14.8	36.9	41.6	61.6

**IMPORTANT:** The above ratings are only for reference. Refer to ASME B16.34 for pressure/temperature ratings.

- NOTES:
1. Standard Class: Flanged Ends Sizes ½ through 2-½, only.
  2. Limited Class: Sizes 2-½ and smaller, butt weld and socket weld ends.  
Limited Class: Threaded ends limited to Sizes 1 and smaller, 538°C maximum and pressure class 2500 maximum.
  3. Special Class: Sizes 3 and 4, Butt weld ends only.
  4. Permissible but not recommended for prolonged usage above approximately 427°C.
  5. Shaded ratings exceed those of Edward Valves. Consult your Flowserve sales representative for applications in these ranges.

\* Consult the applicable version of ASME Section III for the correct version of ASME B16.34 to use.

\*\* Pressure - Temperature ratings are from ASME B16.34 "Valves, Flanged, Threaded and Welding Ends". Consult your Flowserve sales representative for Pressure - Temperature ratings of materials not included in this catalog.

## Reference: ASME B16.34 – 2009 Pressure/Temperature Ratings (metric)\*

### Forged Steel Univalves

MATERIAL	TEMP. °C	PRESSURE (BAR)			
		Class 600	Class 1500 (1)	Class 1690	Class 2500
SA105 Limited Class (2) (4)	38	103.4	258.6	291.3	430.9
	50	103.4	258.6	291.3	430.9
	100	103.3	258.2	290.9	430.3
	150	102.1	255.2	287.5	425.3
	200	101.1	252.9	284.9	421.4
	250	101.1	252.6	284.6	421.1
	300	101.1	252.6	284.6	421.1
	325	100.2	250.6	282.3	417.6
	350	97.8	244.6	275.6	407.6
	375	94.2	235.5	265.3	392.5
	400	86.8	217	244.5	361.7
	425	71.9	179.8	202.6	299.6
	450	57.5	143.8	162	239.6
	475	43.6	109	122.8	181.6
	500	29.6	74.6	84.1	125.4
	538	15.2	39.4	44.8	69

**IMPORTANT: The above ratings are only for reference. Refer to ASME B16.34 for pressure/temperature ratings.**

- NOTES:
1. Standard Class: Flanged Ends Sizes ½ through 2-½, only.
  2. Limited Class: Sizes 2-½ and smaller, butt weld and socket weld ends.  
Limited Class: Threaded ends limited to Sizes 1 and smaller, 538°C maximum and pressure class 2500 maximum.
  3. Special Class: Sizes 3 and 4, Butt weld ends only.
  4. Permissible but not recommended for prolonged usage above approximately 427°C.
  5. Shaded ratings exceed those of Edward Valves. Consult your Flowserve sales representative for applications in these ranges.

\* Consult the applicable version of ASME Section III for the correct version of ASME B16.34 to use.

\*\* Pressure - Temperature ratings are from ASME B16.34 "Valves, Flanged, Threaded and Welding Ends". Consult your Flowserve sales representative for Pressure - Temperature ratings of materials not included in this catalog.

## Reference: ASME B16.34 – 2009 Pressure/Temperature Ratings\*

### Forged Steel Univalves

MATERIAL	TEMP. °C	PRESSURE (PSIG)	
		Class 1500 (1)	Class 2500
<b>SA182 F22 Standard Class (4) (5)</b>	100	3750	6250
	200	3750	6250
	300	3640	6070
	400	3530	5880
	500	3325	5540
	600	3025	5040
	650	2940	4905
	700	2840	4730
	750	2660	4430
	800	2540	4230
	850	2435	4060
	900	2245	3745
	950	1930	3220
	1000	1335	2230
	1050	875	1455
	1100	550	915
	1150	345	570
1200	205	345	
<b>SA182 F22 Special Class (3) (4) (5)</b>	100	3750	6250
	200	3750	6250
	300	3695	6160
	400	3640	6065
	500	3620	6035
	600	3605	6010
	650	3580	5965
	700	3535	5895
	750	3535	5895
	800	3535	5895
	850	3385	5645
	900	3000	5000
	950	2360	3930
	1000	1670	2785
	1050	1095	1820
	1100	685	1145
	1150	430	715
1200	255	430	

**IMPORTANT:** The above ratings are only for reference. Refer to ASME B16.34 for pressure/temperature ratings.

- NOTES:**
1. Standard Class: Flanged Ends Sizes ½ through 2-½, only. Flanged ends terminate at 1000°F.
  2. Limited Class: Sizes 2-½ and smaller, butt weld and socket weld ends.  
Limited Class: Threaded ends limited to Sizes 1 and smaller, 1000°F maximum and pressure class 2500 maximum.
  3. Special Class: Sizes 3 and 4, Butt weld ends only.
  4. Permissible but not recommended for prolonged usage above approximately 1100°F.
  5. Shaded ratings may require special trim and packing. Consult your Flowserve sales representative for applications in these ranges.

\* Consult the applicable version of ASME Section III for the correct version of ASME B16.34 to use.

\*\* Pressure - Temperature ratings are from ASME B16.34 "Valves, Flanged, Threaded and Welding Ends". Consult your Flowserve sales representative for Pressure -Temperature ratings of materials not included in this catalog.

## Reference: ASME B16.34 – 2009 Pressure/Temperature Ratings\*

### Forged Steel Univalves

MATERIAL	TEMP. °C	PRESSURE (PSIG)	
		Class 1500 (1)	Class 2500
SA182 F22 Limited Class (2) (5)	100	3750	6250
	200	3750	6250
	300	3695	6160
	400	3640	6065
	500	3620	6035
	600	3605	6010
	650	3580	5965
	700	3535	5895
	750	3535	5895
	800	3535	5895
	850	3385	5645
	900	3000	5000
	950	2410	4075
	1000	1785	3120
	1050	1170	2040
	1100	730	1280
1150	460	800	
1200	275	480	

**IMPORTANT:** The above ratings are only for reference. Refer to ASME B16.34 for pressure/temperature ratings.

- NOTES:
1. Standard Class: Flanged Ends Sizes ½ through 2-½, only. Flanged ends terminate at 1000°F.
  2. Limited Class: Sizes 2-½ and smaller, butt weld and socket weld ends.  
Limited Class: Threaded ends limited to Sizes 1 and smaller, 1000°F maximum and pressure class 2500 maximum.
  3. Special Class: Sizes 3 and 4, Butt weld ends only.
  4. Permissible but not recommended for prolonged usage above approximately 1100°F.
  5. Shaded ratings may require special trim and packing. Consult your Flowserve sales representative for applications in these ranges.

\* Consult the applicable version of ASME Section III for the correct version of ASME B16.34 to use.

\*\* Pressure - Temperature ratings are from ASME B16.34 "Valves, Flanged, Threaded and Welding Ends". Consult your Flowserve sales representative for Pressure - Temperature ratings of materials not included in this catalog..

## Reference: ASME B16.34 – 2009 Pressure/Temperature Ratings (metric)\*

### Forged Steel Univalves

RATING	TEMP. °C	PRESSURE (BAR)	
		Class 1500 (1)	Class 2500
<b>SA182 F22 Standard Class (4) (5)</b>	38	258.6	430.9
	50	258.6	430.9
	100	257.6	429.4
	150	250.8	418.2
	200	243.4	405.4
	250	231.8	386.2
	300	214.4	357.1
	325	206.6	344.3
	350	201.1	335.3
	375	194.1	323.2
	400	183.1	304.9
	425	175.1	291.6
	450	169	281.8
	475	158.2	263.9
	500	140.9	235
	538	92.2	153.7
	550	78.2	130.3
	575	52.6	87.7
600	34.4	57.4	
625	22.3	37.2	
650	14.2	23.6	

**IMPORTANT: The above ratings are only for reference. Refer to ASME B16.34 for pressure/temperature ratings.**

- NOTES:
1. Standard Class: Flanged Ends Sizes ½ through 2-½, only. Flanged ends terminate at 538°C.
  2. Limited Class: Sizes 2-½ and smaller, butt weld and socket weld ends.  
Limited Class: Threaded ends limited to Sizes 1 and smaller, 538°C maximum and pressure class 2500 maximum.
  3. Special Class: Sizes 3 and 4, Butt weld ends only.
  4. Permissible but not recommended for prolonged usage above approximately 595°C.
  5. Shaded ratings may require special trim and packing. Consult your Flowserve sales representative for applications in these ranges.

\* Consult the applicable version of ASME Section III for the correct version of ASME B16.34 to use.

\*\* Pressure - Temperature ratings are from ASME B16.34 "Valves, Flanged, Threaded and Welding Ends". Consult your Flowserve sales representative for Pressure -Temperature ratings of materials not included in this catalog.

## Reference: ASME B16.34 – 2009 Pressure/Temperature Ratings (metric)\*

### Forged Steel Univalves

RATING	TEMP. °C	PRESSURE (BAR)	
		Class 1500 (1)	Class 2500
SA182 F22 Special Class (3) (4) (5)	38	258.6	430.9
	50	258.6	430.9
	100	258.1	430.2
	150	254.8	424.6
	200	251.1	418.5
	250	249.9	416.5
	300	248.9	414.8
	325	248	413.3
	350	246	410
	375	243.8	406.3
	400	243.8	406.3
	425	243.8	406.3
	450	235.8	393.1
	475	213.7	356.3
	500	178.6	297.5
	538	115.2	192.1
	550	97.7	162.8
	575	65.8	109.7
	600	43	71.7
625	27.9	46.5	
650	17.7	29.5	

**IMPORTANT:** The above ratings are only for reference. Refer to ASME B16.34 for pressure/temperature ratings.

- NOTES:
1. Standard Class: Flanged Ends Sizes ½ through 2-½, only. Flanged ends terminate at 538°C.
  2. Limited Class: Sizes 2-½ and smaller, butt weld and socket weld ends.  
Limited Class: Threaded ends limited to Sizes 1 and smaller, 538°C maximum and pressure class 2500 maximum.
  3. Special Class: Sizes 3 and 4, Butt weld ends only.
  4. Permissible but not recommended for prolonged usage above approximately 595°C.
  5. Shaded ratings may require special trim and packing. Consult your Flowserve sales representative for applications in these ranges.

\* Consult the applicable version of ASME Section III for the correct version of ASME B16.34 to use.

\*\* Pressure - Temperature ratings are from ASME B16.34 "Valves, Flanged, Threaded and Welding Ends". Consult your Flowserve sales representative for Pressure -Temperature ratings of materials not included in this catalog.

## Reference: ASME B16.34 – 2009 Pressure/Temperature Ratings (metric)\*

### Forged Steel Univalves

RATING	TEMP. °C	PRESSURE (BAR)	
		Class 1500 (1)	Class 2500
<b>SA182 F22 Limited Class (2) (5)</b>	38	258.6	430.9
	50	258.6	430.9
	100	258.1	430.2
	150	254.8	424.6
	200	251.1	418.5
	250	249.9	416.5
	300	248.9	414.8
	325	248	413.3
	350	246	410
	375	243.8	406.3
	400	243.8	406.3
	425	243.8	406.3
	450	235.8	393.1
	475	213.7	356.3
	500	181.2	304.8
	538	123.1	215.2
	550	104.4	182.3
	575	70.3	122.9
600	46	80.3	
625	29.8	52.1	
650	18.9	33	

**IMPORTANT: The above ratings are only for reference. Refer to ASME B16.34 for pressure/temperature ratings.**

- NOTES:
1. Standard Class: Flanged Ends Sizes ½ through 2-½, only. Flanged ends terminate at 538°C.
  2. Limited Class: Sizes 2-½ and smaller, butt weld and socket weld ends.  
Limited Class: Threaded ends limited to Sizes 1 and smaller, 538°C maximum and pressure class 2500 maximum.
  3. Special Class: Sizes 3 and 4, Butt weld ends only.
  4. Permissible but not recommended for prolonged usage above approximately 595°C.
  5. Shaded ratings may require special trim and packing. Consult your Flowserve sales representative for applications in these ranges.

\* Consult the applicable version of ASME Section III for the correct version of ASME B16.34 to use.

\*\* Pressure - Temperature ratings are from ASME B16.34 "Valves, Flanged, Threaded and Welding Ends". Consult your Flowserve sales representative for Pressure -Temperature ratings of materials not included in this catalog.



## Reference: ASME B16.34 – 2009 Pressure/Temperature Ratings\*

### Forged Steel Univalves

MATERIAL	TEMP. °C	PRESSURE (PSIG)		
		Class 1500 (1)	Class 1690	Class 2500
SA182 F316 Standard Class (4)	100	3600	4055	6000
	200	3095	3485	5160
	300	2795	3150	4660
	400	2570	2895	4280
	500	2390	2690	3980
	600	2255	2540	3760
	650	2210	2490	3680
	700	2170	2445	3620
	750	2135	2405	3560
	800	2110	2380	3520
	850	2090	2355	3480
	900	2075	2340	3460
	950	1930	2175	3220
	1000	1820	2050	3030
	1050	1800	2030	3000
	1100	1525	1720	2545
	1150	1185	1335	1970
	1200	925	1045	1545
	1250	735	830	1230
	1300	585	660	970
1350	480	540	800	
1400	380	430	630	
1450	290	325	485	
1500	205	230	345	

**Important: The above ratings are only for reference. Refer to ASME B16.34 for pressure / temperature ratings.**

- NOTES:
1. Standard Class: Flanged Ends Sizes ½ through 2-½, only. Flanged ends terminate at 1000°F.
  2. Limited Class: Sizes 2-½ and smaller, butt weld and socket weld ends.  
Limited Class: Threaded ends limited to Sizes 1 and smaller, 1000°F maximum and pressure class 2500 maximum.
  3. Special Class: Sizes 3 and 4, Butt weld ends only.
  4. Shaded ratings may require special trim and packing. Consult your Flowserve sales representative for applications in these ranges.

\* Consult the applicable version of ASME Section III for the correct version of ASME B16.34 to use.

\*\* Pressure - Temperature ratings are from ASME B16.34 "Valves, Flanged, Threaded and Welding Ends". Consult your Flowserve sales representative for Pressure -Temperature ratings of materials not included in this catalog.

## Reference: ASME B16.34 – 2009 Pressure/Temperature Ratings\*

### Forged Steel Univalves

MATERIAL	TEMP. °C	PRESSURE (PSIG)		
		Class 1500 (1)	Class 1690	Class 2500
<b>SA182 F316 Special Class (3) (4)</b>	100	3750	4225	6250
	200	3455	3895	5760
	300	3120	3515	5200
	400	2865	3230	4775
	500	2665	3000	4440
	600	2520	2840	4195
	650	2465	2775	4105
	700	2425	2730	4040
	750	2385	2685	3975
	800	2355	2655	3930
	850	2330	2625	3885
	900	2315	2610	3860
	950	2290	2580	3815
	1000	2105	2370	3505
	1050	2105	2370	3505
	1100	1905	2145	3180
	1150	1480	1665	2465
	1200	1155	1300	1930
	1250	920	1035	1535
	1300	730	820	1215
1350	600	675	1000	
1400	470	530	785	
1450	365	410	605	
1500	260	290	430	

**Important: The above ratings are only for reference. Refer to ASME B16.34 for pressure / temperature ratings.**

- NOTES:
1. Standard Class: Flanged Ends Sizes ½ through 2-½, only. Flanged ends terminate at 1000°F.
  2. Limited Class: Sizes 2-½ and smaller, butt weld and socket weld ends.  
Limited Class: Threaded ends limited to Sizes 1 and smaller, 1000°F maximum and pressure class 2500 maximum.
  3. Special Class: Sizes 3 and 4, Butt weld ends only.
  4. Shaded ratings may require special trim and packing. Consult your Flowserve sales representative for applications in these ranges.

\* Consult the applicable version of ASME Section III for the correct version of ASME B16.34 to use.

\*\* Pressure - Temperature ratings are from ASME B16.34 "Valves, Flanged, Threaded and Welding Ends". Consult your Flowserve sales representative for Pressure -Temperature ratings of materials not included in this catalog.

## Reference: ASME B16.34 – 2009 Pressure/Temperature Ratings\*

### Forged Steel Univalves

MATERIAL	TEMP. °C	PRESSURE (PSIG)		
		Class 1500 (1)	Class 1690	Class 2500
SA182 F316 Limited Class (2) (4)	100	3750	4225	6250
	200	3455	3895	5760
	300	3120	3515	5200
	400	2865	3230	4775
	500	2665	3000	4440
	600	2520	2840	4195
	650	2465	2775	4105
	700	2425	2730	4040
	750	2385	2685	3975
	800	2355	2655	3930
	850	2330	2625	3885
	900	2315	2610	3860
	950	2290	2580	3815
	1000	2105	2370	3505
	1050	2105	2370	3505
	1100	1945	2200	3300
	1150	1580	1795	2760
	1200	1235	1405	2160
	1250	985	1120	1720
	1300	780	885	1360
1350	640	730	1120	
1400	500	570	880	
1450	390	445	680	
1500	280	315	480	

**Important: The above ratings are only for reference. Refer to ASME B16.34 for pressure / temperature ratings.**

NOTES: 1. Standard Class: Flanged Ends Sizes ½ through 2-½, only. Flanged ends terminate at 1000°F.

2. Limited Class: Sizes 2-½ and smaller, butt weld and socket weld ends.

Limited Class: Threaded ends limited to Sizes 1 and smaller, 1000°F maximum and pressure class 2500 maximum.

3. Special Class: Sizes 3 and 4, Butt weld ends only.

4. Shaded ratings may require special trim and packing. Consult your Flowsolve sales representative for applications in these ranges.

\* Consult the applicable version of ASME Section III for the correct version of ASME B16.34 to use.

\*\* Pressure - Temperature ratings are from ASME B16.34 "Valves, Flanged, Threaded and Welding Ends". Consult your Flowsolve sales representative for Pressure -Temperature ratings of materials not included in this catalog.

## Reference: ASME B16.34 – 2009 Pressure/Temperature Ratings (metric)\*

### Forged Steel Univalves

MATERIAL	TEMP. °C	PRESSURE (BAR)		
		Class 1500 (1)	Class 1690	Class 2500
<b>SA182 F316 Standard Class (4)</b>	38	248.2	279.6	413.7
	50	240.6	271.1	400.9
	100	211	237.7	351.6
	150	192.5	216.9	320.8
	200	178.3	200.9	297.2
	250	166.9	188	278.1
	300	158.1	178.1	263.5
	325	154.4	174	257.4
	350	151.6	170.8	252.7
	375	149.4	168.3	249
	400	147.2	165.8	245.3
	425	145.7	164.2	242.9
	450	144.2	162.5	240.4
	475	143.4	161.5	238.9
	500	140.9	158.8	235
	538	125.5	141.3	208.9
	550	124.9	140.7	208
	575	119.7	134.9	199.5
	600	99.5	112.1	165.9
	625	79.1	89.1	131.8
650	63.3	71.3	105.5	
675	51.6	58.1	86	
700	41.9	47.2	69.8	
725	34.9	39.3	58.2	
750	29.3	33	48.9	
775	22.8	25.7	38	
800	17.4	19.6	29.2	
816	14.1	15.9	23.8	

**Important: The above ratings are only for reference. Refer to ASME B16.34 for pressure / temperature ratings.**

- NOTES:
1. Standard Class: Flanged Ends Sizes ½ through 2-½, only. Flanged ends terminate at 538°F.
  2. Limited Class: Sizes 2-½ and smaller, butt weld and socket weld ends.  
Limited Class: Threaded ends limited to Sizes 1 and smaller, 538°F maximum and pressure class 2500 maximum.
  3. Special Class: Sizes 3 and 4, Butt weld ends only.
  4. Shaded ratings may require special trim and packing. Consult your Flowserve sales representative for applications in these ranges.

\* Consult the applicable version of ASME Section III for the correct version of ASME B16.34 to use.

\*\* Pressure - Temperature ratings are from ASME B16.34 "Valves, Flanged, Threaded and Welding Ends". Consult your Flowserve sales representative for Pressure -Temperature ratings of materials not included in this catalog.

## Reference: ASME B16.34 – 2009 Pressure/Temperature Ratings (metric)\*

### Forged Steel Univalves

MATERIAL	TEMP. °C	PRESSURE (BAR)		
		Class 1500 (1)	Class 1690	Class 2500
SA182 F316 Special Class (3) (4)	38	258.6	291.3	430.9
	50	254.1	286.3	423.5
	100	235.5	265.3	392.4
	150	214.8	242	358
	200	199	224.2	331.7
	250	186.3	209.9	310.4
	300	176.4	198.8	294.1
	325	172.3	194.1	287.2
	350	169.2	190.7	282.1
	375	166.7	187.8	277.9
	400	164.3	185.1	273.8
	425	162.6	183.2	271.1
	450	161	181.4	268.3
	475	160	180.3	266.6
	500	158.6	178.7	264.3
	538	145.1	163.5	241.7
	550	145.1	163.5	241.7
	575	143	161.1	238.3
	600	124.4	140.2	207.3
	625	98.8	111.3	164.7
650	79.1	89.1	131.9	
675	64.5	72.7	107.5	
700	57.1	64.3	95.2	
725	47.7	53.7	79.5	
750	36.7	41.4	61.2	
775	28.5	32.1	47.6	
800	22	24.8	36.6	
816	17.9	20.1	29.6	

**Important: The above ratings are only for reference. Refer to ASME B16.34 for pressure / temperature ratings.**

- NOTES:
1. Standard Class: Flanged Ends Sizes ½ through 2-½, only. Flanged ends terminate at 538°F.
  2. Limited Class: Sizes 2-½ and smaller, butt weld and socket weld ends.  
Limited Class: Threaded ends limited to Sizes 1 and smaller, 538°F maximum and pressure class 2500 maximum.
  3. Special Class: Sizes 3 and 4, Butt weld ends only.
  4. Shaded ratings may require special trim and packing. Consult your Flowserve sales representative for applications in these ranges.

\* Consult the applicable version of ASME Section III for the correct version of ASME B16.34 to use.

\*\* Pressure - Temperature ratings are from ASME B16.34 "Valves, Flanged, Threaded and Welding Ends". Consult your Flowserve sales representative for Pressure -Temperature ratings of materials not included in this catalog.

## Reference: ASME B16.34 – 2009 Pressure/Temperature Ratings (metric)\*

### Forged Steel Univalves

MATERIAL	TEMP. °C	PRESSURE (BAR)		
		Class 1500 (1)	Class 1690	Class 2500
<b>SA182 F316 Limited Class (2) (4)</b>	38	258.6	291.3	430.9
	50	254.1	286.3	423.5
	100	235.5	265.3	392.4
	150	214.8	242	358
	200	199	224.2	331.7
	250	186.3	209.9	310.4
	300	176.4	198.8	294.1
	325	172.3	194.1	287.2
	350	169.2	190.7	282.1
	375	166.7	187.8	277.9
	400	164.3	185.1	273.8
	425	162.6	183.2	271.1
	450	161	181.4	268.3
	475	160	180.3	266.6
	500	158.6	178.7	264.3
	538	145.1	163.5	241.7
	550	145.1	163.5	241.7
	575	114.0	162.4	241.2
	600	128.2	145.1	218.2
	625	105.6	120.0	184.5
650	84.5	96.1	147.7	
675	68.9	78.3	120.4	
700	61	69.4	106.6	
725	51	57.9	89	
750	39.2	44.6	68.5	
775	30.5	34.6	53.3	
800	23.5	26.7	41	
816	19.1	21.7	33.2	

**Important: The above ratings are only for reference. Refer to ASME B16.34 for pressure / temperature ratings.**

- NOTES:
1. Standard Class: Flanged Ends Sizes ½ through 2-½, only. Flanged ends terminate at 538°F.
  2. Limited Class: Sizes 2-½ and smaller, butt weld and socket weld ends.  
Limited Class: Threaded ends limited to Sizes 1 and smaller, 538°F maximum and pressure class 2500 maximum.
  3. Special Class: Sizes 3 and 4, Butt weld ends only.
  4. Shaded ratings may require special trim and packing. Consult your Flowserve sales representative for applications in these ranges.

\* Consult the applicable version of ASME Section III for the correct version of ASME B16.34 to use.

\*\* Pressure - Temperature ratings are from ASME B16.34 "Valves, Flanged, Threaded and Welding Ends". Consult your Flowserve sales representative for Pressure -Temperature ratings of materials not included in this catalog.





• **Seats** – Industrial globe valves are available from various manufacturers with a broad variety of seat designs—flat or tapered, and integral or inserted (threaded or welded).

All Edward globe valves employ tapered seats with “area contact” under load to seal over minor imperfections. Many similar valves use “line-contact” seats that seal with less load when new but degrade rapidly if damaged at the seating line.

Except for hydraulic stop valves, all Edward globe valves employ integral (hardfaced) body seats to permit compact design and ensure that there can be no leakage “behind” the seat.

• **Disc Guiding** – Globe valve discs can be guided by either the stem or the body. When opened or closed under very high differential pressure, side load due to flow pushes a stem-guided disc eccentric to the seat and makes it difficult to obtain a seal. Under extreme conditions, the stem may bend.

All Edward globe valves employ body-guided discs that are held closely concentric with the body seat. Guiding is provided at both the top and bottom of the disc to form a fully body-guided disc piston. The bottom guide ring on the disc, a Flowserve Edward Valves innovation, minimizes flow behind the disc and minimizes the side load. These features make Edward globe valves well suited to “blowdown” applications in which there is a high differential pressure across the valve when it is partially open.

Since globe valves are not symmetrical with respect to flow, consideration must be given to the direction of flow and differential pressure. It should be noted that the direction of flow when open and differential pressure when closed may not be the same in all applications (e.g., a block valve on a feed line may involve flow into a system when open but may need to prevent leakage out of the

system when closed). Users should consider both factors when deciding on the installation direction for a globe valve.

In most globe valve applications, pressure is under the seat when the valve is closed, and the flow is from under to over the seat (termed “flow to open” or “underseat flow”). In installations where the downstream pressure is zero or very low, this arrangement minimizes packing leakage problems. However, handwheel or actuator effort to close the valve is high, because the stem must supply enough load to both overcome the differential pressure load across the seat area and ensure sufficient sealing load on the metal seat-contact surfaces. Since this flow direction is the most common for globe valves, the flow coefficients given in the Flow Performance section of this catalog are for underseat flow.

Globe valves can also be used with overseat flow and pressure (“flow to close”), but such applications require careful consideration. In systems with dirty line fluids, this arrangement could lead to trapping foreign material in locations where it would interfere with opening. With overseat pressure, the effort to close the valve is low, because closure and sealing are pressure-assisted. However, the effort to open the valve at high differential pressure is high, because the stem must overcome the pressure force to lift the disc (in small valves, the stem diameters approaching the seat diameter, this may not be a problem, because the pressure helps to lift the stem). Also, since the flow coefficients given in this catalog are for underseat flow, pressure-drop predictions may not be as accurate (pressure drop may be up to 10% higher with overseat flow).

While not designed as control valves and not recommended for continuous modulation, Edward globe valves are often used successfully for manual or automatic control during limited periods of system operation (start-up, shutdown, etc.). Some manual valves are also used for continuous throttling or “trimming.” Inclined-bonnet valves, (e.g., Univalves and Flite-Flow valves) have an approximately linear flow characteristic ( $C_v$  versus % open).

The Flow Performance section of this catalog covers only flow coefficients for fully open valves, but consult Flowserve concerning applications involving flow control. It should be understood that severe throttling at high-pressure drops involves high-energy dissipation, and serious problems (e.g., noise, vibration, cavitation, erosion) can develop if not carefully considered when a system is designed.



### Gate Valves

A gate valve employs a closure member (or assembly) that opens and closes by moving perpendicular to the flow stream to engage two seats in the body. There are two basically different types of gate valves—parallel-side and wedge gate—in common use in pressure-piping systems, but there are many variations in design within each type.

As compared to globe valves, all gate valves offer straight-through flow paths that tend to produce less pressure drop than typical globe valves of the same nominal size. A Venturi gate valve with a smaller port versus a regular gate valve may offer a lower first cost as well as a size and weight saving if a minimized pressure drop is not required.

The Flow Performance section of this catalog gives comparable flow coefficients for Edward Equiwedge® gate valves and all Edward globe stop valves. Evaluation of many valve applications has shown that inclined-bonnet globe valves are often competitive with gate valves when all factors are considered.

The stem in a gate valve does not have to overcome the full differential pressure load across the valve seat area to open or close the valve. Instead, it just has to overcome the friction force due to that load. Consequently, for operation at similar differential pressures, a gate valve generally requires less effort for actuation than a globe valve and can employ a smaller actuator when powered operation is required. However, a gate valve requires considerably greater stem travel than a conventional globe or angle valve (slightly greater than an inclined-bonnet globe valve), so a somewhat longer time may be required for action.

The two body seats – the common feature in all ordinary gate valves – can be both an advantage and a disadvantage. Most gate valves are primarily “downstream-sealing,” because the closure member is pressure-energized in that direction. However, the upstream seating surfaces may help by limiting leakage if the



# 1. Stop and Check-Valve Applications Guide

## 1.1 Stop Valve Applications

### Foreword

Edward stop valves are used primarily as isolation valves in medium and high-pressure piping systems. They are offered in a broad range of sizes, pressure ratings and types, and they are used in an immense array of diverse applications. Only a few are listed for illustration:

- Normally open valves in main steam lines; used only for equipment isolation, e.g., during maintenance.
- Normally open valves to provide for emergency shutoff due to failure of downstream piping or other equipment; closed periodically for verification of operability.
- Normally open valves that are throttled to varying degrees during start-up or shutdown of plants or systems.
- Frequently cycled valves that are opened and closed for control of batch processes or for start-up and shutdown of equipment (e.g., equipment that is on-stream daily but shut down at night).
- Normally closed valves; used only for filling or draining systems during outages.

Stop valves are sometimes referred to as “on-off valves.” They should not normally be considered as “control valves,” but they are suitable for moderate or infrequent flow-control functions. Valves that must open and close under high differential pressure and flow conditions (such as “blowdown” service) inherently function as flow-control devices while they are stroking.

Considering the diversity of stop valve applications, it is not surprising that there is no universal valve type that is best for all services. Users’ experience with specific applications is a valuable basis for selecting the best valves.

The goal of this guide is to supplement users’ experience with information based on decades of Flowserve Edward Valves’ laboratory tests and field experience.

### Introduction

While many other types of valves (ball, plug, butterfly) are used as stop valves where

service conditions permit, emphasis in this guide is on selection and application of Edward valves with forged- and cast-steel bodies and bonnets. Comparisons are presented with other similar valves where appropriate.

Edward stop valves are typically of metal-seated construction and, where necessary, use gaskets and stem seals designed for severe high-pressure, high-temperature service. While special designs with “soft seats” and O-ring seals are supplied for unique specific applications, the standard products are designed to stand up to tough service conditions with minimum requirements for maintenance or parts replacement.

Edward stop valves fall into two basic categories – **globe valves** and **gate valves**. The following sections of this guide will address the principal features of each type and the design variations within the types.

Globe valves are offered in stop, stop-check, and check versions. Stop-check valves can also be used for isolation in unidirectional flow applications. These valves are discussed in the Check Valve Applications Guide section (1.2).

The FLOW PERFORMANCE section of this catalog provides equations and coefficients for the calculation of pressure drop across any of these valves. This information can be used to evaluate the effects of different valve sizes and types of system energy efficiency.

### 1.1.1 Stop Valve Types and Typical Uses

Brief notes on the advantages, disadvantages, applications and limitations of the various types of Edward stop valves are presented in the Stop Valve Applications Chart (section 1.1.5). Some additional highlights of the features of these valves and some comparisons with similar valves are presented in the following paragraphs.

#### Globe Valves

A globe valve employs a poppet or disc that opens and closes by moving linearly along the seat axis. There are many types of globe valve bodies, seats and methods of guiding the disc to and from the seat.

- **Bodies** – Edward stop, stop-check and check-type globe valves are offered with three basic body styles:

**Conventional or 90° bonnet globe valves** are usually the most compact, and the stem and yoke position allow easy handwheel or actuator access and convenience for maintenance. Relatively short stem travel allows fast actuation. Multiple direction changes in the flow stream result in higher pressure drop than with other types, but streamlined flow passages in Flowserve Edward valves generally yield lower pressure drop than competitive valves of this type.

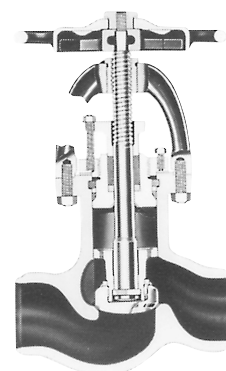

**Angle valves** are otherwise similar to conventional globe valves, but the less tortuous flow path yields lower pressure drop. Angle valves are particularly economical in piping layouts where use of this configuration eliminates an elbow and associated flanged or welded joints.

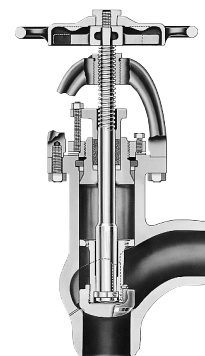

**Inclined bonnet or “Y type” valves**, such as Univalves® and Flite-Flow® valves, yield lower pressure drop than other styles, because they permit a more nearly straight-through flow path. Typically, they require a longer stem travel. In large sizes, this body shape is heavier and requires a greater end-to-end length than conventional globe valves.

downstream seat is damaged. Simultaneous sealing at both seats can be hazardous if the center cavity of a closed valve is filled or partially filled with liquid and then subjected to an increase in temperature, causing a corresponding increase in pressure. In moderate cases, this may cause “pressure binding,” which can impede or prevent valve opening; in extreme cases, it may cause pressure-boundary failure (e.g., the bonnet could blow off).

*Note: ASME/ANSI B16.34-1988 (paragraph 2.3.3) places the responsibility of the purchaser to ensure that the pressure in the valve will not exceed that allowed by the standard. Special operating procedures, such as partially opening a valve during warm-up, may be considered. Special internal design features or external bypass arrangements are required in many applications. Consult Flowserve regarding Edward Equiwedge gate valve applications that may be subject to possible center-cavity over-pressurization.*

Some highlights of the various types of gate valves, including the Edward Equiwedge, are discussed below:

• **Parallel-Slide Gate Valves**

Flowserve Edward Valves does not offer parallel-slide valves. In these valves, the two seats in the body are in parallel planes, and an assembly including two gates with parallel seating faces moves into or out of engagement with the body seats. The gates are urged into contact with the opposing seats in the closed position by either a spring (or a set of springs) or an internal wedge mechanism.

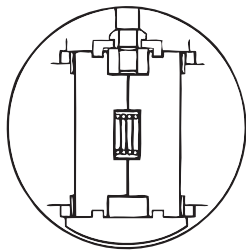

**Parallel Slide Gate**

Since the two gates are relatively independent, the downstream gate is free to align with the downstream seat, and new valves usually seal well so long as the differential pressure across the valve is sufficient to provide adequate seating load. Leakage may be a problem with these valves at low differential pressures (e.g. when filling a system or during low-pressure start-up operation).

In typical parallel-slide valves, there is continuous sliding contact between the sealing surfaces of the gates and body seats throughout the full stem stroke. Wearing or scoring is possible, particularly when operating with high differential pressures, and this

may cause seat sealing to be degraded. This shearing action may be helpful in cleaning loose debris from the seats, however.

• **Wedge Gate Valves**

A wedge gate valve uses one of the oldest engineering principles to provide mechanical advantage to convert stem load to seat-sealing load. This is particularly important in low-pressure applications where differential pressure alone may not provide sufficient loading on the downstream seat.

Early wedge gate valves for low pressure employed solid wedges, and these are still used in many small high-pressure gate valves. However, as industrial valve requirements moved toward larger sizes and higher pressures and temperatures, a solid wedge designed to provide sufficient strength became too rigid to accommodate the flexibility of the valve body. The seat planes deflect significantly in large, high-pressure valve bodies due to thermal effects and the loads from connecting piping, and a rigid wedge may either leak or bind in the closed position.

Many gate valves have been designed with “flexible” one-piece wedges that have overcome these problems to some degree, but the two halves of the wedge are not truly independent and free to align with the two opposing body seats. It is particularly difficult to provide torsional flexibility in the wedge to accommodate twist in the valve body.

Consequently, the Edward Equiwedge valve was designed with two independent, flexible wedge halves that permit relative rotation and can tilt to accommodate changes in the body-seat angles. The thickness of the wedges was minimized, while maintaining acceptable stresses, to allow deflection to accommodate out-of-flatness in the seat plane. In prototype tests, acceptable sealing was maintained with seats intentionally misaligned 1° in angle and up to 2° in rotation.

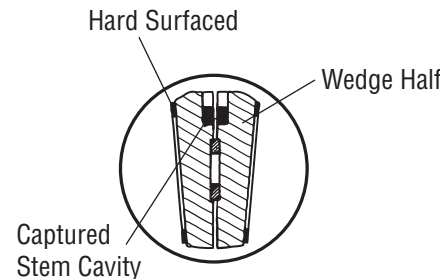

**Double Wedge Design**

The result is a valve that has high-pressure sealing performance comparable to that of a parallel-slide valve but that can also seal exceptionally well at low differential pressures. The independent, flexible wedge halves in Edward Equiwedge gate valves also have commendable resistance to sticking or binding in the closed position. In prototype tests, the valve always opened with a torque less than the design closing torque when exposed to extreme pipe-bending moments and severe thermal transients (heat-up and cool-down).

All wedge gate valves have body guides that must support the wedges when they are not in the fully closed position. The seating surfaces of the wedges and seats are in sliding contact only through a small portion of the opening and closing travel, thus minimizing wear that may degrade seat sealing. Outside that range, the side loads are transferred from the seats to the body guides. Wear or scoring of the body guides does not affect sealing.

In Edward Equiwedge gate valves, the body guides are vertical machined grooves at each side of the valve body, which engage tongues on each side of the wedge halves. Precision machining allows transfer of side load from the seats to the body guides within 3% to 5% of valve travel. Testing has proven that this guiding system is rugged and supports the gate assembly effectively, even in “blowdown” services where high differential pressure loads act across the gates when the valve is partially open.

Gate valves of any type are usually not recommended for throttling or modulating flow-control service. The seating surfaces of the gates are subject to impingement when partially open, and some gate valves reportedly exhibit instability (internal vibration) when throttled. Nevertheless, high-velocity flow tests of a prototype Edward Equiwedge gate valve produced no flow-induced vibration, and there are cases where these valves have been used successfully for limited flow-control functions. Consult Flowserve concerning any proposed throttling or control applications.

**1.1.2 Throttling Characteristics of Edward Stop Valves**

As noted in the previous section, Edward stop valves are not normally recommended for continuous modulation, and Edward Valves should be consulted concerning applications involving flow control. This

section is intended only to provide general guidelines on flow-control characteristics of typical Edward stop valves. These guidelines may be used for preliminary studies relating to applications involving throttling, but they should not be considered as a substitute for a complete evaluation of the acceptability of a valve for a critical application.

Figure A

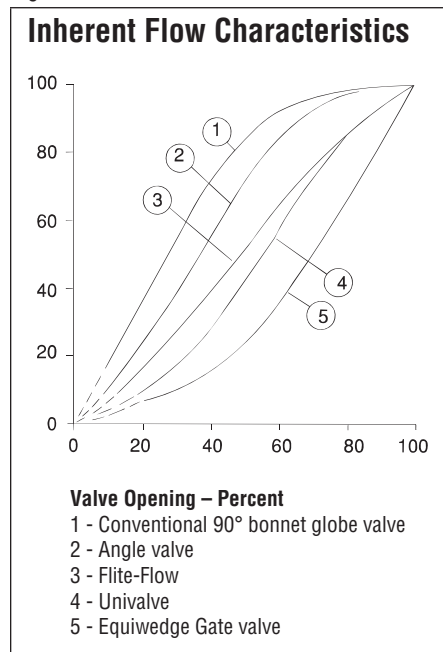

Figure A provides typical **inherent flow-characteristic** curves (percent of full-open flow coefficient versus percent opening) of the most common types of Edward stop valves. It should be understood that these curves are approximate, because there are variations due to size and pressure class that cannot be represented accurately by a single curve for each valve type. Nevertheless, these typical curves can provide some guidance relating to control capabilities of the various valve types.

Note the following subtle differences between the curves in Figure A:

- The conventional 90° bonnet globe valve provides a relatively steep slope at small openings approaching a “quick-opening” characteristic. While the body-guided disc in Edward globe valves moderates this effect, it makes the flow coefficient very sensitive to small changes in stem position, so it may prove difficult to control low flow rates.
- The angle valve has a characteristic similar to that of a globe valve, but it is slightly

closer to linear due to its normally higher full-open flow coefficient. An angle valve has about the same control characteristics as a globe valve of the same size at small openings.

- The cast-steel Flite-Flow Y-type valve provides a characteristic that is nearly linear over most of its stem-travel range. For control of flow over a broad range, the high flow efficiency of this type of valve may permit use of a smaller valve size for a given allowable pressure drop. The smaller size, combined with the linear characteristic, can give improved control of low flow rates when the valve is throttled.
- The forged-steel Y-type Univalve provides even better control at very small openings because of its “double throttling” characteristic as the lower disc-guide ring opens the machined port in the body. Other forged-steel valves have this characteristic to some degree.
- The Equiwedge gate valve has an excellent inherent flow characteristic (“concave upward”), approaching that of an **equal-percentage** control valve. However, this is somewhat misleading. When installed in pipe of the same nominal size as the valve, the pressure drop of a gate valve is so low at large openings (e.g., over 70%) that piping flow resistance usually overshadows that of the valve. The gate valve would provide little control over flow in that range.

While not normally recommended for throttling for the reasons cited in the previous section, the gate valve flow-characteristic curve is attractive from a standpoint of controlling low flow rates without excessive sensitivity. Use of a gate valve for throttling may be considered for some applications.

### 1.1.3 Stop Valve Actuators and Accessories

Most Edward stop and stop-check valves illustrated in this catalog are shown with handwheels, and the majority of valves are furnished for applications where manual actuation is acceptable. Most larger and higher-pressure globe valves are furnished with standard Impactor handles or handwheels, which provide up to twelve times the stem force of an ordinary handwheel, to provide for adequate seating thrust. Impactogear assemblies on the largest globe valves permit operation using an air wrench. These Flowserve Edward Valves innovations permit practical manual operation of many valves

that would otherwise require gearing or power actuators.

### Manual Gear Actuators

When specified, many Edward valves can be supplied with manual actuators with gear reduction in lieu of a handwheel. Such actuators reduce the required rim-pull effort and often permit operation by one person in cases where several people would be required to seat the valve with a handwheel. While manual gear actuators slow down operation, they are often an attractive option for valves that are not operated frequently. Operating pressure and differential pressure should be specified.

*Note: Users sometimes specify that valves be operable at maximum differential pressure with very low rim-pull forces. This may require selection of gearing that may cause two problems: (1) literally thousands of handwheel turns for full-stroke valve operation and/or (2) capability to damage the valve easily with rim-pull forces that are readily applied by many operating personnel. Manual gear actuators with high ratios provide relatively little “feel” to the operator, and it is difficult to tell when a valve is fully open or closed. Good judgment should be exercised in specifying practical rim-pull force requirements.*

### Power Actuators

Where valves are inaccessible for manual operation or where relatively fast opening or closing is required, most Edward valves can be furnished with power actuators. The most commonly used actuators are electric actuators with torque- and position-control features. Users frequently have individual preferences on actuator brand names and type, so Edward valves can be furnished with Flowserve actuators or other brand actuators to satisfy customer requirements.

Flowserve establishes actuator sizes and switch setting based on specific valve-application requirements, using a computer program that matches the valve and actuator operating characteristics to the service-pressure conditions. Flowserve can help make this selection since we best know the requirements of our valve. However, we must also know the requirements of your application. As a minimum, requests for quotation should specify:

- Operating pressures – under-and over-seat and differential
- Maximum valve operating temperature
- Ambient conditions – temperature, humidity, radiation
- Motor power supply – AC voltage, frequency, and phase or DC voltage (including variance)

- NEMA rating
- Closing/opening time – if important. If not specified, standard nominal stem speed will be 4 inches/minute (100 mm/min) for globe valves and 12 inches/min (305 mm/min) for gate valves.
- Valve-stem plane – vertical (stem up or down) or horizontal
- Special accessories – position indicator, etc.

Any other special requirements should be clearly specified. If there are non-standard manual-override requirements, see the note on the previous page regarding rim-pull forces for manual gear actuators.

### Stored-Energy Actuators

For critical service applications, special balanced Flite-Flow valves and Equiwedge gate valves are furnished with Edward stored-energy actuators that were developed and qualified to meet demanding nuclear power-plant requirements. These linear actuators are commonly installed on Main Steam Isolation Valves and Main Feedwater Isolation Valves (MSIV and MFIV) that must be adjustable to close in 3 to 10 seconds in the event of a line break.

The Edward actuator completed exhaustive qualification testing under elevated temperatures, radiation, seismic loadings and other conditions that realistically simulated the most severe operating conditions encountered in actual service. In addition, extensive qualification testing was done on an Equiwedge MSIV in combination with an Edward

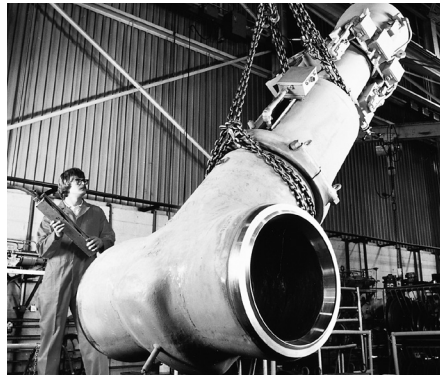

actuator, and over 160 of these combinations are installed in nuclear plants on three continents.

The Edward actuator employs compressed gas—the stored energy of closure of the valve—in a compact, essentially spherical reservoir atop the piston of the valve-actuating cylinder. This integral construction eliminates reliance on external gas-storage tanks or interconnecting piping to connect the stored-energy gas to the power cylinder. Hydraulic fluid is pumped into the cylinder below the piston to open the valve, and regulated release of the fluid to a reservoir provides essential closing-speed control.

### 1.1.4 By-Passes and Drains

When specified, larger Edward cast-steel valves are furnished with valved by-passes and drains in accordance with ASME-ANSI B16.34 and MSS SP-45. Cast-steel stop valves employ forged-steel Edward globe

stop valves, and cast-steel stop-check valves use forged steel Edward stop-check valves as by-pass valves. Sizes and by-pass valve figure numbers are as shown on page 196.

Drain valves for all main valves are the same as the by-pass valves listed for stop valves. When drains are specified without valves, the standard drain for class 300 and 600 valves is an NPT tapped hole in the valve body, fitted with a pipe plug. For class 900 and higher-pressure valves, the standard drain is a pipe nipple, six inches (152 mm) long, socket-welded to the valve body.

Drain sizes are the same as by-passes. By-pass valves are particularly useful when opened before the main valve to permit controlled warming of the valve and downstream line in services involving steam or other hot fluids. By-passes also can be used to partially or fully balance the differential pressure across the main valve before opening where the downstream line or system is of limited volume. This facilitates opening of a gate valve or a glove valve with overseat pressure.

Large-volume systems may require larger by-passes for balancing in a reasonable time. If this is the case, a special by-pass size should be specified by the purchaser. It should be noted that actuated Edward Equiwedge gate valves do not require by-passes to permit opening if the full differential pressure is specified for actuator sizing. See page 196 for tables of standard sizes and pressure classes for most applications.

General schematic of stored energy gas-hydraulic actuator.

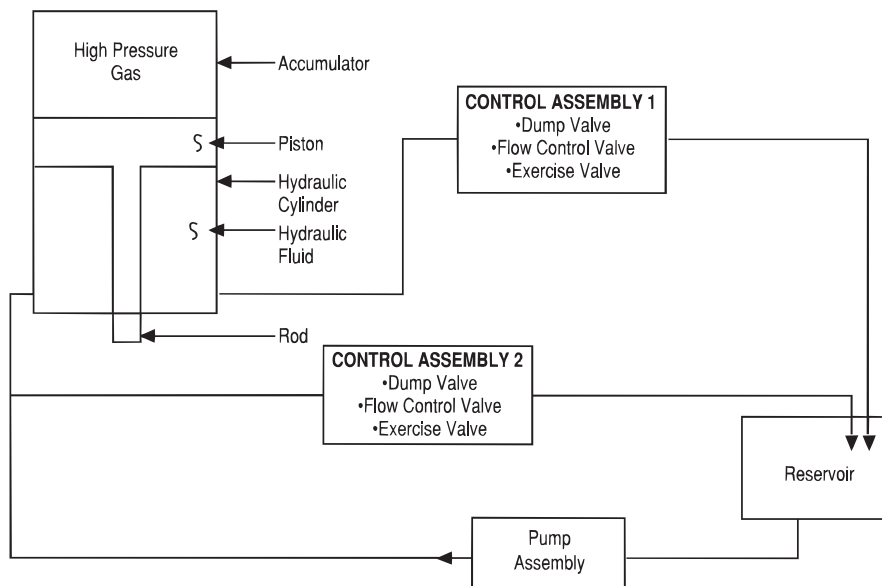

### 1.1.5 Stop Valve Applications Chart

Type	Advantages	Disadvantages	Applications	Limitations
<b>Globe 90° Bonnet</b>	<ul style="list-style-type: none"> <li>• Compact</li> <li>• Easy access to handwheel or actuator</li> <li>• Fast response</li> </ul>	<ul style="list-style-type: none"> <li>• High pressure drop</li> <li>• High torque</li> <li>• Heavy in large sizes</li> </ul>	<ul style="list-style-type: none"> <li>• Class 300-2500 steam and water</li> <li>• Other gasses and liquids</li> <li>• Usable for throttling</li> </ul>	<ul style="list-style-type: none"> <li>• Not for stem-down installations</li> <li>• Sizes ¼" through 24"</li> </ul>
<b>Angle</b>	<ul style="list-style-type: none"> <li>• Same as globe</li> <li>• Replaces an elbow</li> <li>• Lower pressure drop than globe</li> </ul>	<ul style="list-style-type: none"> <li>• High torque</li> <li>• Heavy in large sizes</li> </ul>	<ul style="list-style-type: none"> <li>• Same as globe</li> </ul>	<ul style="list-style-type: none"> <li>• Same as globe</li> </ul>
<b>Globe Inclined Bonnet</b>	<ul style="list-style-type: none"> <li>• Lower pressure drop than globe or angle</li> <li>• May permit smaller size than globe</li> </ul>	<ul style="list-style-type: none"> <li>• Same as angle</li> <li>• Longest end-to-end length</li> <li>• Handwheel or actuator on an angle</li> <li>• Long stem travel slows response</li> </ul>	<ul style="list-style-type: none"> <li>• Class 600-4500 through size 4</li> <li>• Class 300-2500 through size 24</li> <li>• Otherwise, same as globe</li> </ul>	<ul style="list-style-type: none"> <li>• Same as globe</li> </ul>
<b>Equiwedge® Gate</b>	<ul style="list-style-type: none"> <li>• Lowest pressure drop</li> <li>• Lowest torque</li> <li>• May permit smallest size</li> </ul>	<ul style="list-style-type: none"> <li>• Not recommended for throttling</li> <li>• Long stem travel slows response with manual actuation</li> </ul>	<ul style="list-style-type: none"> <li>• Class 600-2500 steam and water</li> <li>• Other gasses and liquids</li> <li>• Main steam isolation</li> </ul>	<ul style="list-style-type: none"> <li>• Possibility of pressure binding</li> <li>• Sizes 2½" through 32"</li> </ul>
<b>Flex Wedge Gate</b>	<ul style="list-style-type: none"> <li>• Lowest pressure drop</li> <li>• Lowest torque</li> <li>• May permit smallest size</li> <li>• Best general purpose gate valve</li> </ul>	<ul style="list-style-type: none"> <li>• Not recommended for throttling</li> <li>• Long stem travel slows response with manual actuation</li> <li>• Not suited for severe service</li> </ul>	<ul style="list-style-type: none"> <li>• Class 150-2500 steam and water</li> <li>• Other gases and liquids</li> </ul>	<ul style="list-style-type: none"> <li>• Possibility of pressure binding</li> <li>• Possibility of thermal binding</li> <li>• Sizes 2½" through 32"</li> </ul>
<b>Double-Disc Gate</b>	<ul style="list-style-type: none"> <li>• Lowest pressure drop</li> <li>• Tightest sealing</li> <li>• Immune to thermal binding</li> </ul>	<ul style="list-style-type: none"> <li>• Not quoted for turbulent flow or severe service</li> </ul>	<ul style="list-style-type: none"> <li>• Class 150-2500 steam and water</li> <li>• Other gases and liquids</li> <li>• Main steam isolation</li> </ul>	<ul style="list-style-type: none"> <li>• Possibility of pressure binding</li> <li>• Sizes ½" through 32"</li> </ul>

## 1.2 Check Valve Applications Guide

### Foreword

Check valves are used in fluid circuits in applications similar to those in which diodes are used in electrical circuits. Reduced to simplest terms, the duty of most check valves is to allow flow in one direction and to prevent flow in the reverse direction. The ideal check would have zero resistance to flow in the normal flow direction and infinite resistance to flow (leakage) in the reverse direction. Of course, the ideal check valve should also be perfectly reliable and should require no maintenance.

There are many different types of check valves, and most do their duty well, giving long, trouble-free service. However, in the real world, no single type of check valve achieves the ideal performance characteristics users sometimes expect. In a very few cases, mismatching of check valves to the needs of fluid circuits has produced serious problems (noise, vibration, severe pressure surges and check-element failures with attendant gross leakage and consequential damage to other equipment). While it is not necessary for every application to be ideal, knowledge of the characteristics of each type of check valve should help system designers and valve users to select the best type and size intelligently. This knowledge should also help in ensuring that serious problems are avoided.

Most check valves seem deceptively simple, with only one moving part—a poppet or flapper that appears capable of allowing flow in only one direction. However, this single mechanical part cannot be expected to take the place of a sophisticated control system that senses flow (direction, quantity, rate of change) and provides output to (1) open the valve fully when flow is in one direction and yet (2) close the valve to prevent flow and leakage in the reverse direction. Each type of check valve has features that enable it to perform one or more of its duties well, but each type also has weaknesses. The relative importance of these strengths and weaknesses is highly dependent on the requirements of individual applications.

The goal of this guide is to provide application engineers and users with practical advice on check valve selection and sizing, location in piping systems, preventive maintenance and repairs. Emphasis will be on Flowserve Edward Valves products, but

comparisons will be provided in some cases with other types of check valves.

This guide is based on extensive testing of Edward check valves in sizes from NPS ½ through 18 as well as a reasonable sampling of other types. Since complete performance testing of every valve type, size and pressure class is not practical, predictions of the performance of some valves are based on mathematical models. However, the models are based on substantial test data and are believed to be reasonably accurate or conservative. The laboratory test files cover over 40 years. Perhaps even more important, the files include feedback from substantial field experience—in fossil and nuclear-fueled power plants, refineries, chemical plants, oil fields and in countless other applications. It is hoped that this test and field experience will help others avoid problems and pitfalls in the application and use of check valves.

### Introduction

This guide has been prepared to aid fluid-system designers in sizing and selecting check valves for industrial and power-piping systems. Guidance is also provided on valve orientation (inclination from horizontal, etc.) and on location of check valves with respect to other flow disturbances. In addition, this guide should aid users in planning preventive maintenance programs, performing maintenance and repairs when necessary, and in evaluating and correcting problems.

Emphasis in this guide is on selection and application of forged- and cast-steel Edward Valves products, but comparisons with other types of check valves are given where this can be done based on valid information.

The Flow Performance section of this catalog provides equations and coefficients for the calculation of pressure drop and the flow required to ensure full valve opening. In addition, that section provides most of the necessary supplemental data required for routine calculations, such as water and steam density.

This guide also provides caution notes relative to system-related problems to be avoided (such as piping vibration, flow instability, waterhammer). Some of these guidelines are qualitative and could involve further analysis. However, attention to these notes should help to avoid problems.

Finally, this guide addresses check valve maintenance. History indicates that preventive maintenance of check valves is often

neglected, and this can lead to serious valve failures which may damage other equipment. The guidelines provided on periodic inspection and preventive maintenance should pay off in terms of reduced overall plant maintenance and repair costs.

### 1.2.1 Check Valve Types and Typical Uses

While other types are sometimes encountered in power hydraulics and other specialized applications, four basic types of check valves are commonly used in industrial and power piping applications.

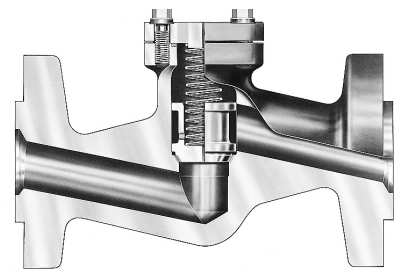

#### 1-Lift Check Valves

The closure element is a poppet or disc that is lifted open by flow and which seats, usually on a mating conical surface in the valve body, under no-flow conditions.

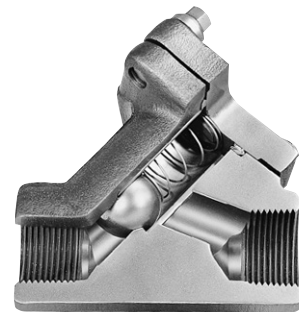

#### 2-Ball Check Valves

A lift check valve in which the closure element is a ball.

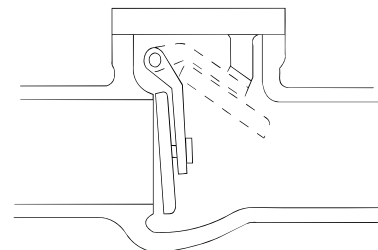

### 3-Swing Check Valves

The closure element is a pivoted flapper that is swung open by flow and which seats, generally against a mating flat surface in the valve body, under no-flow conditions.

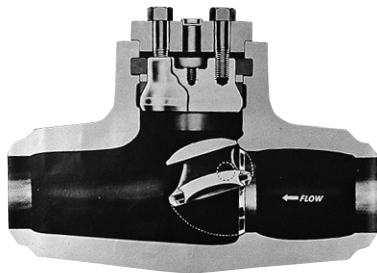

### 4-Tilting-Disc Check Valve

The closure element is a pivoted disc or flapper, somewhat like that in a swing check valve but with a pivot axis close to the center of the flow stream. It is swung open by flow and seats against a mating conical surface in the valve body under no-flow conditions.

There are many variations among these four basic types of check valves. For example, springs may be included to assist closure and counteract gravitational forces, and accessories may be provided for exercising or position indication. All Edward lift check valves employ body-guided discs with a piston-like extension to provide good guidance and resistance to wear. Accordingly, they are referred to in this guide as piston-lift check valves. In addition, Flowserve manufactures Edward stop-check valves that are piston-lift check valves that allow positive closure for isolation, just like globe stop valves.

Illustrations of the Edward valve types manufactured by Flowserve are provided in this catalog, and brief notes on advantages, disadvantages, applications, and limitations are provided in the Check Valve Applications Chart (section 1.2.2). Some further highlights of the features of these valves are provided in the following paragraphs.

### Edward Piston-Lift Check Valves

In both small forged-steel and large cast-steel Edward lines, three distinctly different valve body styles appear in the illustrations – inclined-bonnet globe valve style, angle valve style, and 90° bonnet globe valve style.

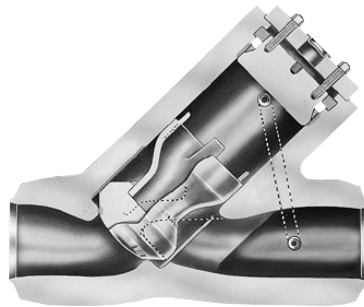

With respect to check valve function, these valves are all similar, with only slightly different orientation limits as discussed in the Valve-Installation Guidelines section (1.3). The main difference between these systems is in flow performance:

- Inclined-bonnet piston-lift check valves produce low pressure drop due to flow when fully open. They have flow coefficients comparable to those of tilting-disc check valves and only slightly lower than provided by many swing check valves.
- In most cases, angle piston-lift check valves have lower flow coefficients and thus produce more pressure drop than inclined-bonnet valves, but they are superior to 90° bonnet valves. Where a piping system requires a bend and a valve, use of an angle piston-lift check valve eliminates the cost and pressure drop of an elbow and the cost of associated piping welds or flanged connections.
- 90° bonnet piston-lift check valves have the lowest flow coefficients and produce pressure drops comparable to 90° bonnet globe valves. They are sometimes preferred in systems where pressure drop is not critical or where space requirements dictate a minimum size and easy access to a handwheel or actuator (on a stop-check valve).

Piston-lift check valves are generally the most practical type for small sizes, and they generally provide the best seat tightness. Small forged-steel piston-lift check valves normally include a disc-return spring, but may be ordered without springs. The Flow Performance section of this catalog and section 1.3 on page 250 address such valves, both with and without springs. Cast-steel piston-lift check valves have equalizer tubes which connect the volume above the piston with a relatively low-pressure region near the valve outlet. This feature allows a much larger valve opening (and higher flow coefficient) than would be possible otherwise, and

it allows the valve to open fully at a relatively low flow.

The body-guided feature of Edward piston-lift check valves is an advantage in most services, because it ensures good alignment of the disc with the valve seat and minimizes lateral vibration and wear. However, this feature may lead to sticking problems due to foreign-material entrapment in unusually dirty systems. Another inherent characteristic is that large piston-lift check valves may not respond rapidly to flow reversals and may cause waterhammer problems in systems where the flow reverses quickly [see the Pressure Surge and Waterhammer section (1.4.2)]. Since smaller valves display inherently faster response, historic files have shown no waterhammer problems with small forged-steel check valves.

### Edward Stop-Check Valves

Stop-check valves offer the same tight sealing performance as a globe stop valve and at the same time give piston-lift check valve protection in the event of backflow. A stop-check valve is nearly identical to a stop valve, but the valve stem is not connected to the disc. When the stem is in the “open” position, the disc is free to open and close in response to flow, just as in a piston-lift check valve. When serving as a check valve, stop-check valves display the same advantages and disadvantages as discussed above for piston-lift check valves. Small forged-steel stop-check valves, except the Univalve stop-check valves, employ a disc-return spring, and cast-steel stop-check valves have equalizer tubes that function in the same manner as those on comparable piston-lift check valves.



The stem in the stop-check valve may be driven either by a handwheel or an actuator, and it may be used either to (1) prevent flow in the normal direction when necessary for isolation or (2) supplement line pressure to

enhance seat tightness in applications with pressure from the downstream side. Some users automate stop-check valves to give extra system protection against reverse flow and leakage. For example, an actuator may be signaled to close the valve when a pump is shut off; the disc closes quickly by normal check valve action, and the stem follows to seat the valve firmly a short time later.

### Edward Ball Check Valves

Ball check valves are offered only in small forged-steel configurations (size 2 and smaller) with inclined-bonnet bodies and ball-return springs. These valves are recommended over piston check valves, for service with viscous fluids or where there is scale or sediment in the system. The bolted-bonnet versions offer flow performance that is generally similar to that of equivalent piston-lift check valves, and they are the preferred ball check valves for most industrial and power-piping applications.

The threaded-bonnet hydraulic ball check valves are used primarily in very high-pressure, low-flow applications with viscous fluids. They have lower flow coefficients that have proven acceptable for those services. These valves sometimes exhibit chattering tendencies when handling water, so they are not recommended for low-viscosity fluids.

A unique feature of the ball check valve is that the ball closure element is free to rotate during operation, allowing the ball and seat to wear relatively evenly. This feature, combined with the standard return spring, helps to promote positive seating even with heavy, viscous fluids.

### Edward Tilting-Disc Check Valves

Tilting-disc check valves are particularly well-suited to applications where rapid response and freedom from sticking are essential. Fully open valves of this type also exhibit low pressure drop. They have flow coefficients comparable to those of Edward inclined-bonnet piston-lift (Flite-Flow) check valves and only slightly lower than provided by many swing check valves.

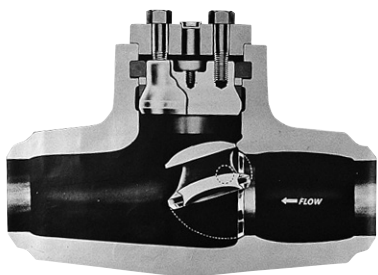

Tilting-disc check valves provide rapid response, because the center of mass of the disc is close to the pivot axis. Just as in a pendulum, this characteristic promotes rapid motion of the disc toward its natural (closed) position whenever the force holding it open is removed. This response can be valuable in applications where relatively rapid flow reversals may occur, such as in pump-discharge service where multiple pumps discharge into a common manifold. In such cases, the flow may reverse quickly, and the rapid response of the tilting-disc check valve minimizes the magnitude of the reverse velocity and the resulting waterhammer pressure surge. This characteristic also minimizes impact stresses on the disc and body seats. However, an extremely rapid flow reversal, as might be produced by an upstream pipe rupture, could cause a problem. See the Pressure Surge and Waterhammer section (1.4.2) for further discussion.

Size 6 and larger tilting-disc check valves have totally enclosed torsion springs in their hinge pins to help initiate the closing motion, but the disc is counterweighted to fully close without the springs. With the free pivoting action of the disc, this type of valve is highly immune to sticking due to debris in the system.

Tilting-disc check valves are superficially similar to swing check valves in that both operate on a pivoting-disc principle. However, the pivot axis in a swing check valve is much farther from the disc's center of mass, and this increases the "pendulum period" and hence the time required for closure in services with flow reversal. In addition, the one-piece disc in the tilting-disc check valve avoids the necessity of internal fasteners and locking devices, which are required to secure discs to pivot arms in most swing check valves. However, like swing check valves, tilting-disc check valves have hinge pins and bearings that are subject to wear due to disc flutter if the valve is not fully open and/or there are flow disturbances or instabilities. Such wear may produce eccentricity of the disc and seat when the valve closes, leading to a degradation of seat tightness (particularly at low differential pressures). Applications involving severely unstable flow or prolonged service without preventive maintenance can lead to failures in which the disc separates completely from the hinge pins and will not close. Other sections of this guide address the flow conditions which may lead to problems as well as maintenance recommendations.

### Edward Elbow-Down Check and Stop-Check Valves

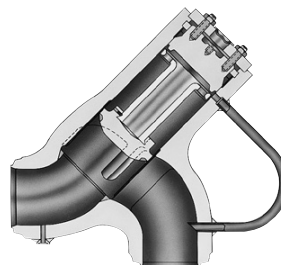

Elbow-down piston-lift check and stop-check valves are similar to Flite-Flow valves except that the valve outlet is in the form of an elbow to direct the flow downward. These valves were designed specifically for applications in controlled-circulation power plants, and they have special clearances and other design features. Because of these special features, the sizing and pressure-drop calculation methods given in the Flow Performance section of this catalog do not apply. However, special elbow-down valves can be furnished with conventional check valve design features for applications where this valve-body geometry is desirable.



### Edward Combinations of Check and Stop-Check Valves

As noted in the Foreword to this section (1.2), no single type of check valve achieves ideal performance characteristics. The advantages and disadvantages noted in the Check Valve Applications Chart (section 1.2.2) and other information in this catalog should assist in selection of the best valve size and type for any specific application. However, the selection of any single valve may require undesirable compromises.

Some system designers and users specify two check valves in series for critical applications, and this does give some insurance



### 1.2.2 Check Valve Applications Chart

Type	Advantages	Disadvantages	Applications	Limitations
<b>Piston Lift Check</b>	<ul style="list-style-type: none"> <li>• Very low pressure drop in inclined bonnet valves</li> <li>• Relatively low pressure drop in angle valves</li> <li>• Larger valves incorporate an external equalizer</li> <li>• Minimum chatter due to flow disturbances</li> <li>• Good seat tightness</li> <li>• Forged steel valves with spring can be mounted in any orientation</li> </ul>	<ul style="list-style-type: none"> <li>• Relatively high pressure drop in 90° bonnet valves</li> <li>• Subject to “sticking” in very dirty systems</li> </ul>	<ul style="list-style-type: none"> <li>• Class 300-4500 service</li> <li>• High temperature steam and water</li> <li>• Refining, petrochemical, chemical, etc.</li> <li>• Oilfield production</li> <li>• Can be used in series with Tilting-Disc Check to provide maximum line protection (advantages of both types)</li> </ul>	<ul style="list-style-type: none"> <li>• Sizes ¼" through 24"</li> <li>• For orientation limits, see valve installation guidelines</li> <li>• For flow limits, see Flow Performance section of this catalog</li> </ul>
<b>Ball Check</b>	<ul style="list-style-type: none"> <li>• Wear on body seat and check element evenly distributed</li> <li>• Long service life</li> <li>• Forged steel valves with spring can be mounted in any orientation</li> <li>• Available with either integral or threaded seat for hydraulic valve</li> <li>• Low cost</li> </ul>	<ul style="list-style-type: none"> <li>• High pressure drop</li> <li>• Available only in small sizes</li> </ul>	<ul style="list-style-type: none"> <li>• Class 600 and Series 1500 service</li> <li>• Water, steam, refining, petrochemical, chemical, etc.</li> <li>• Service where scale and sediment exist</li> <li>• Viscous fluids</li> </ul>	<ul style="list-style-type: none"> <li>• Sizes ¼" through 2"</li> <li>• For orientation limits see valve installation guidelines</li> <li>• Not recommended for gas service at low flow rates</li> <li>• For flow limits, see Flow Performance section of this catalog</li> </ul>
<b>Tilting-Disc Check</b>	<ul style="list-style-type: none"> <li>• Very low pressure drop</li> <li>• Straight through body design</li> <li>• Very fast closing</li> <li>• Minimizes disc slamming and waterhammer pressure surges</li> <li>• Will not “stick” in dirty systems</li> </ul>	<ul style="list-style-type: none"> <li>• Not recommended for service with rapidly fluctuating flow</li> <li>• Seat tightness may deteriorate at low differential pressure</li> </ul>	<ul style="list-style-type: none"> <li>• Class 600-4500 service</li> <li>• High temperature steam and water</li> <li>• Refining, petrochemical, chemical, etc.</li> <li>• Oilfield production</li> <li>• Can be used in series with Piston Lift check or Stop-Check to provide maximum line protection (advantages of both types)</li> </ul>	<ul style="list-style-type: none"> <li>• Sizes 2½" through 24"</li> <li>• For orientation limits, see valve installation guidelines</li> <li>• For flow limits, see Flow Performance section of this catalog</li> </ul>
<b>Stop Check</b>	<ul style="list-style-type: none"> <li>• See Piston Lift Check above</li> <li>• Can be used for Stop valve service</li> <li>• Stem can be lowered onto disc to prevent chatter at low flow</li> <li>• Stem force can overcome “sticking”</li> </ul>	<ul style="list-style-type: none"> <li>• See Piston Lift Check valve above</li> </ul>	<ul style="list-style-type: none"> <li>• See Piston Lift Check above</li> </ul>	<ul style="list-style-type: none"> <li>• See Piston Lift Check above</li> </ul>
<b>Swing Check</b>	<ul style="list-style-type: none"> <li>• Best general service check valve</li> <li>• Tight sealing</li> <li>• Lowest pressure drop</li> </ul>	<ul style="list-style-type: none"> <li>• Not good for low or pulsating flows</li> <li>• Slower response to reverse flow</li> <li>• Susceptible to causing waterhammer</li> </ul>	<ul style="list-style-type: none"> <li>• Class 150-2500 service</li> <li>• High temperature steam and water including containment isolation</li> </ul>	<ul style="list-style-type: none"> <li>• Sizes 2½" through 24"</li> </ul>

that at least one valve will close even if the other valve fails. However, if two identical valves are used, a system characteristic that is troublesome to one valve could produce problems with both. In such cases, use of two valves does not ensure double safety or double life. Sometimes it is worth considering the selection of two different types of check valve, each with advantages to offset disadvantages of the other.

One specific check valve combination has been used in applications of Flowserve Edward valves to provide advantages that no single valve can offer. A tilting-disc check valve in series with a piston-lift check valve offers minimum waterhammer and freedom from sticking (from the tilting disc) and good seat tightness (from the piston-lift check). The disadvantage is added pressure drop and cost, but the pressure-drop penalty is minor if the Flite-Flow inclined-bonnet piston-lift check valve is used. Even the cost penalty may be offset if a stop-check valve is used, because it may be able to take the place of a stop valve that would be required otherwise for isolation.

### 1.3 Check and Stop-Check Valve Installation Guidelines

Unlike stop valves, which can be installed in any position with little or no effect on performance, most check and stop-check valves have limitations as to their installed orientation. Although the normal installation is in a horizontal or vertical line (depending on valve type), check and stop-check valves can be installed in other orientations. It should be noted, however, that valves installed in other than the normal positions may exhibit a degradation of performance, service life and resistance to sticking, depending on the flow conditions and cleanliness of the line fluid. For maximum reliability, it is recommended that piston-lift check valves and stop-check valves be installed with flow axis horizontal (vertical inlet and horizontal outlet for angle valves) with the bonnet above the valve in a vertical plane. Following are maximum out-of-position orientations that may be used for less critical applications and which should never be exceeded.

- All Edward forged-steel check and stop-check valves (except Univalve stop-check valves) are normally furnished with spring-loaded discs and may be installed in any position. The spring-loaded disc enables positive closure regardless of valve position.

**Figure 1**  
45° Inclined Bonnet Piston Lift Check Valves  
Maximum Check Valve Orientation Limits

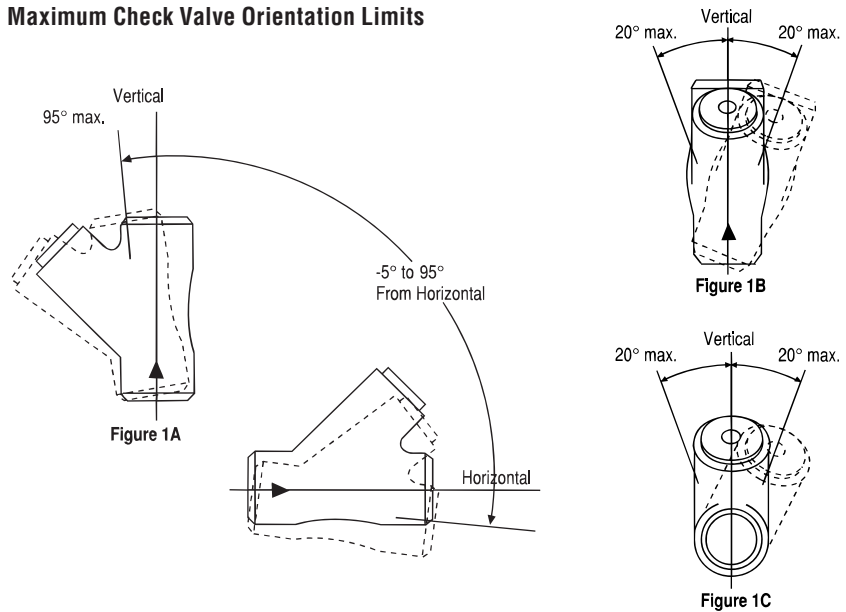

**Figure 2**  
90° Bonnet Piston Lift Check Valves  
Maximum Valve Orientation Limits

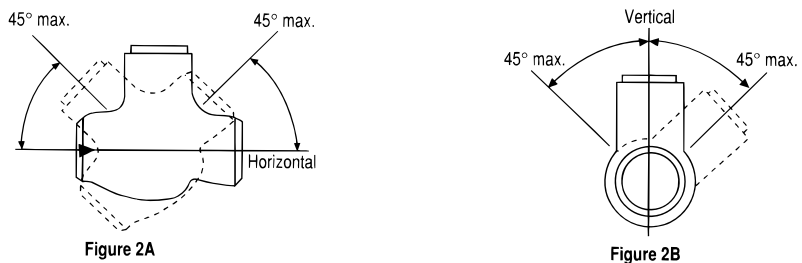

*Note: For piston lift check valves, any installation resulting in combined out-of-position orientation, such as a valve in an inclined line with a rollover angle as well, should limit the angle of the bonnet to the following:*

- 45° from vertical for angle and 90° bonnet valves.
- 50° from vertical for inclined bonnet valves.

However, installed positions in which dirt or scale can accumulate in the valve neck should be avoided. An example of this would be an inclined-bonnet valve installed in a vertical pipeline with downward flow. If forged-steel valves are ordered without springs, the limitations below should be observed.

- Edward cast-steel Flite-Flow, forged-steel Univalve, and inclined-bonnet check and stop-check valves without springs, when installed in vertical or near vertical lines,

should be oriented such that the fluid flow is upward and the angle of incline of the line is not more than 5° past the vertical in the direction of the bonnet. When installed in horizontal or near horizontal lines, the valve bonnet should be up and the angle of incline of the line should be not more than 5° below the horizontal. See Figure 1A. Also, the roll angle of the valve bonnet should not be more than 20° from side to side for either vertical or horizontal installations. See Figures

**Figure 3**  
Angle Piston Lift Check Valves  
Orientation Limits

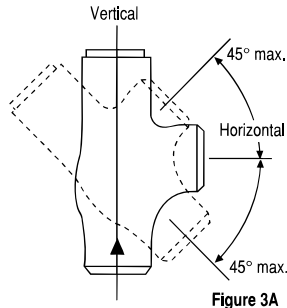

Figure 3A

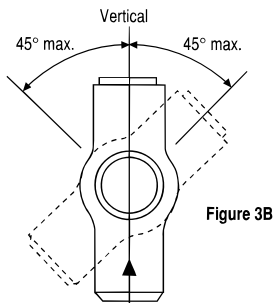

Figure 3B

**Figure 4**  
Tilting-Disc Check Valves  
Orientation Limits

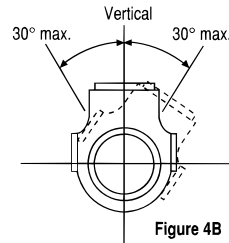

Figure 4B

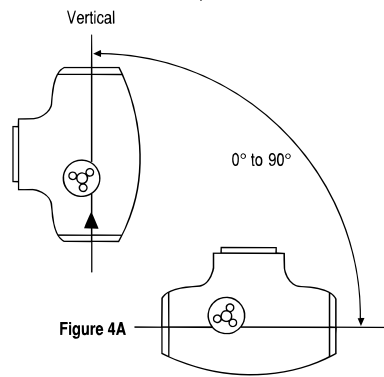

Figure 4A

1B and 1C. Consult your Flowserve Edward Valves representative concerning installation limits of bolted-bonnet forged-steel check valves without springs.

- Edward cast-steel and forge-steel 90° bonnet check and stop-check valves without springs should be installed with the bonnet up, and the angle of incline of the line should not be more than 45° from the horizontal. Also, the roll angle of the valve bonnet should not be more than 45° from side to side. See Figures 2A and 2B.

- Edward cast-steel and forged-steel angle check and stop-check valves without springs should be oriented such that the incoming flow is upward, and the angle of incline of the line should not be more than 45° in either direction. See Figures 3A and 3B.

- Edward tilting-disc check valves may be installed in horizontal lines and vertical lines and at any incline angle in between. When the incline angle is not horizontal, flow should always be up. The roll angle of the valve should not be more than 30° from side to side. See Figures 4A and 4B. Also, when installed in other than vertical lines, the bonnet should always be oriented up.

**Figure 5**  
Pipe fittings near valves may produce instability because of velocity profile distortion

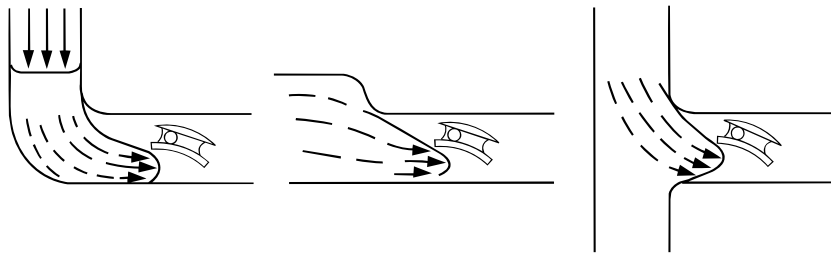

**Figure 6**  
Non-uniform velocity profile at blower or pump discharge can affect stability.

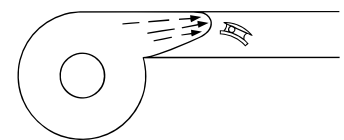

In each case described above, the limitations given for line inclination and bonnet roll angle should not be combined.

It should be understood that the information given in the section of this catalog titled Flow Performance is based on traditional horizontal orientations. For other orientations, the pressure drop and flow required for full lift may be affected. In addition, seat tightness, particularly at low differential pressures, may be adversely affected.

Orientation restrictions may also exist for power-actuated stop-check valves. Most linear valve actuators are designed to be mounted upright and nearly vertical, although they can usually be modified for mounting in any position. When selecting a stop-check valve and power actuator, be sure to specify the mounting position desired if not vertical and upright.

**Figure 7**  
Elbows in two places cause swirl, which can promote instability.

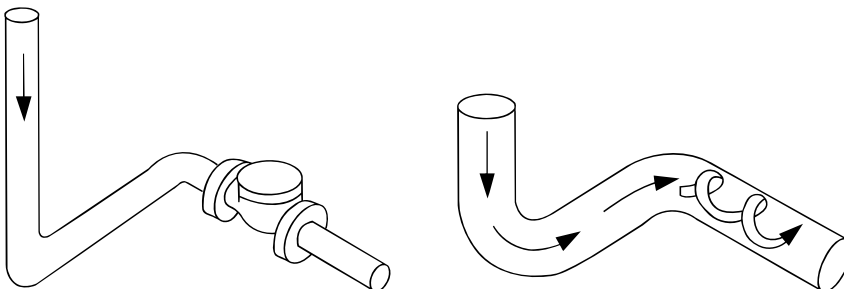

### 1.3.1 Adjacent Flow Disturbances

Check valves, like other valve types, are generally tested for performance and flow capacity in long, straight-pipe runs. Flow coefficients obtained from these tests are then used to predict the flow rate or pressure drop that will be experienced in actual applications. The ideal installation of a check valve in a plant would be in a long run of straight pipe so that performance would correspond to the test conditions. Since space limitations involved with many installations preclude such ideal straight-pipe runs, the effects of adjacent pipe fittings, control valves, pumps and other flow disturbances must be considered.

Previously published data have indicated that flow disturbances, particularly upstream disturbances, may significantly affect check valve performance. It has been reported that valve flow capacity may be significantly reduced as compared to that measured in straight-pipe tests, and there have been strong suggestions that such disturbances aggravate check valve flutter and vibration. Since these conditions could degrade valve performance and contribute to rapid wear and premature valve failure, they are important factors in evaluating check valve applications. Figure 5 illustrates how upstream pipe fittings may alter the flow profile entering a check valve, crowding it to one side or the other. A similar distortion occurs in a valve located near the discharge of a centrifugal pump or blower, as shown in Figure 6. Elbows in two planes cause a flow stream to swirl, which might produce unusual effects on a check valve installed as shown in Figure 7.

Since there was no known way to predict the effects of flow disturbances on check valves by mathematical models, Flowserve conducted extensive testing of size 2, 4, 8 and 10 check valves in straight-pipe runs and in piping with upstream flow disturbances. Figures 8 and 9 illustrate typical flow-test setups.

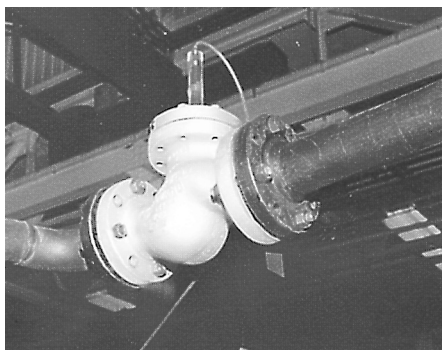

**Figure 8**  
Size 4 Class 600 90° bonnet piston lift check valve with two upstream elbows (out of plane). This arrangement produces swirl as shown in Figure 7.

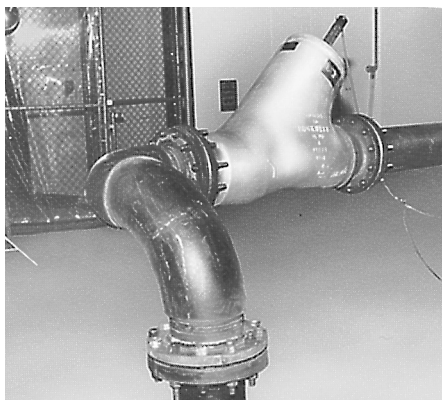

**Figure 9**  
Size 10 Class 1500 Flite-Flow inclined bonnet piston lift check valve with two upstream elbows. Test loop capacity permitted tests with line velocity over 20 ft/s (6 m/s).

In most tests, room-temperature water was the flow medium, but limited straight-pipe testing was performed with air. The valves tested included Edward piston-lift check (inclined-bonnet, angle and 90° bonnet), tilting-disc check valves and a size 4 swing check valve manufactured by another company. The tests were designed to evaluate the effects of flow disturbances on (1) valve stability, particularly when partially open; (2) flow rate required to open the valve fully; and (3) the flow coefficient ( $C_v$ ) of the valve. The flow disturbances evaluated included single and double (out of plane) 90° elbows in various orientations immediately upstream of the check valves. In addition, the effects of a throttled, upstream control valve were simulated with an offset-disc butterfly valve (at various throttle positions) mounted immedi-

ately upstream, as well as at five and 11 pipe diameters upstream, of the check valves.

With few exceptions, tests with 10 or more diameters of straight pipe upstream of check valves produced little cause for concern. In water flow tests, visual position indicators usually showed only minor disc “wobble” or very small open-close flutter (e.g., less than 1° total rotation of a tilting disc), even at very low flows and small valve openings. The only conditions that produced severe instability were those involving air flow at very low pressures (below 50 psi or 3.4 bar) and valve openings less than 20%. Such conditions produced significant cyclic motion, with discs bouncing on and off the body seats. In view of the many uncertainties in applying laboratory test results to service conditions, it is considered prudent to avoid operating conditions which produce check valve openings of less than 25%, even in ideal straight-pipe applications.

Highlights of the results of the Flowserve tests with flow disturbances are given in the Check Valve Applications Chart (1.2.2) on page 249. The test program clearly showed that upstream flow disturbances do affect check valve performance, but the effect is not always predictable. The magnitude of the effect can vary, depending on the type and even the size of the valve. In some cases, even the direction of the effect (improvement or degradation) varies from valve to valve. Nevertheless, some general observations on the results of these tests are:

- Single and double upstream elbows produced less severe effects on check valve performance than had been expected, and some valves displayed no discernible effects. For example, Edward angle piston-lift check valves exhibited the same stability, lift and flow coefficients ( $C_v$ ) with upstream elbows as with straight pipe. In tests of other types of valves, upstream elbows produced both beneficial and adverse effect to various degrees.
- In each case where a check valve was tested with a throttled butterfly valve immediately upstream, there were significant effects on performance. The effects included increased disc flutter and reduced valve opening at a given flow, as compared to straight-pipe performance. In some cases, full check valve opening could not be achieved at any flow within the capabilities of the test loop.

Even where full opening was obtained, some valves continued to flutter on and off their

stops. These effects were worst when the butterfly valve was most severely throttled (smallest opening and highest pressure drop). In the worst cases, the butterfly valve exhibited audible cavitation, but it is not clear whether the adverse effects resulted from simple flow distortion or the two-phase flow stream from the cavitating butterfly valve.

In similar tests with the butterfly valve moved 5 diameters upstream of the check valve (but with similar throttling), the adverse performance effects were decreased significantly but not eliminated. When the butterfly valve was moved 11 diameters upstream of the check valve, normal check valve performance was restored.

The results of these tests were enlightening, but they must be combined with observations based on field experience. For example, while upstream elbows produced less severe effects than expected, there were still adverse effects on some valves. It is difficult to extrapolate a laboratory test to years of service in a plant installation, but Flowserve service files include an interesting and relevant incident. Two size-12 tilting-disc check valves in one plant had hinge-pin failures over a time period of several months after 25 years

of service. While this incident might best be cited as a case for more inspection and preventive maintenance, the details of the installation were investigated. It was determined that the flow rates were in a range that should have ensured full disc opening, but the valves were installed close to upstream elbows.

Users of this catalog may wish to refer to EPRI Report No. NP 5479 (see the Sources for Additional Information section of this catalog) for further data on the performance of swing check valves in tests similar to those conducted by Flowserve. The size 4 swing check valve used in the Flowserve test program had a stop positioned to restrict the disc-opening angle to about 38°. This valve opened fully at a relatively low flow and exhibited reasonably stable performance. The tests sponsored by EPRI showed that other swing check valves (with less restrictive stops) exhibited larger amplitudes of flutter than were observed in comparable Flowserve tests.

The following guidelines are based on Flowserve tests and field experience, combined with other published information:

- If possible, check valves near flow disturbances should be sized to be fully open, preferably by a good margin, even at the lowest sustained flow rate anticipated for each application. The Flow Performance section of this catalog provides methods for sizing Edward check valves for new installations or for evaluating existing applications. When flow-induced forces load a valve closure element firmly against a stop, it is less likely to flutter and suffer from rapid wear.

Full opening does not guarantee freedom from problems if the margin is not sufficient to provide a firm load against the stop. Equalizers on Edward cast-steel piston-lift check and stop-check valves enhance this margin and provide good stop loading, but flow disturbances may cause other valve discs to bounce on and off their stops. This “tapping” phenomenon may cause faster wear than flutter about a partially open position. For this reason, the minimum sustained flow rate through a tilting-disc check valve near flow disturbances should be about 20% greater than the flow rate required to just achieve full opening.

If it is not possible to ensure full opening of a check valve at minimum flow conditions,

**Table A – Effects of Upstream Flow Disturbances on Check Valve Performance**

Valve Size and Type	Single Elbow at Valve Inlet <sup>1</sup>	Double Elbows (Out of Plane) at Valve Inlet	Throttled Butterfly Valve		
			At Valve Inlet	5 Diam. Upstream	11 Diam. Upstream
Size 2, Inclined-Bonnet, Piston-Lift Check	Higher Lift for Same Flow; Disc Flutter at Lower Lifts <sup>2</sup>	Higher Lift for Same Flow	NA	NA	NA
Size 4, Angle, Piston-Lift Check	No Effect	No Effect	NA	NA	NA
Size 4, 90° Bonnet, Piston-Lift Check	Same, Lower or Higher Flow for Full Lift	No Effect	Disc Flutter and Chatter: Failure to Achieve Full Open	NA	NA
Size 4, Swing Check	Smaller Opening for Same Flow	Smaller Opening for Same Flow	Larger Opening for Same Flow; Disc Flutter	NA	NA
Size 8, Angle, Piston-Lift Check	No Effect	NA	NA	NA	NA
Size 8, 90° Bonnet, Piston-Lift Check	Disc Flutter at Partial Lift	NA	NA	NA	NA
Size 10, Inclined-Bonnet, Piston-Lift Check	Same or Lower Lift for Same Flow; Slight Disc Wobble	No Effect	Failure to Achieve Full Open; Disc Flutter and Chatter	Failure to Achieve Full Open	No Effect
Size 10, Tilting-Disc Check	No Effect	Minor Flutter	Same, Lower or Higher Lift for Same Flow; Disc Flutter and Chatter	Minor Flutter	No Effect

1: Tests were conducted with single 90° elbows in the horizontal plane and in the vertical plane (with flow both from above and below).

2: One size 2 valve exhibited flutter at lower lifts; another was stable.

at least 25% opening should be ensured. Valves operating at partial opening for significant periods of time should be monitored regularly to determine if there is instability or wear.

- In view of uncertainties associated with long-term effects of flow disturbances, it is recommended that a minimum of 10 diameters of straight pipe be provided between the inlet of a check valve and any upstream flow disturbance (fittings, pumps, control valves, etc.), particularly if calculations indicate that the check valve will not be fully open for a substantial portion of the valve service life. There should be a minimum of 1 to 2 diameters of pipe between the check valve and the nearest downstream flow disturbance.

- In the specific case of upstream elbows, reasonably successful performance should be attainable with 5 diameters of straight pipe between an upstream elbow and a check valve if the valve will not be partially open for a significant portion of its service life. Tests described in EPRI Report No. NP 5479 indicate that elbows installed 5 diameters or more upstream had a negligible effect on swing check valves, and this is expected to be true for other check valve types. Even less straight pipe may be satisfactory, but such close spacing should be reserved for applications with very tight space constraints. More frequent inspection and preventive maintenance should be planned for valves in such installations.

- In the specific case of throttled upstream control valves, the minimum requirement of 10 upstream pipe diameters should be adhered to rigidly. Calculations indicating full valve opening based on straight-pipe tests cannot be trusted to prevent problems, because severe flow disturbances may prevent full opening. Even greater lengths of straight pipe should be considered if the control valve operates with very high pressure drop or significant cavitation.

- Users with existing check valve installations that do not meet these guidelines should plan more frequent inspection and preventive maintenance for such valves. If a check valve is installed close to an upstream control valve that operates with a high-pressure drop, considerations should be given to a change in piping or valve arrangements.

### 1.3.2 Other Problem Sources

In addition to the fundamentals of check valve selection, sizing and installation, several other potential sources of check valve

problems should be considered in applications engineering or, if necessary, in solving problems with existing installations:

#### • Piping-System Vibration

In other sections of this guide, it has been noted that check valve damage or performance problems may result from flow-induced flutter or vibration of the closure element. Very similar damage may result from piping-system vibration. Such vibration may originate at pumps, cavitating control valves or other equipment. Check and stop-check valves are susceptible to vibration damage, because the check element is “free floating” when partially open, with only the forces due to fluid flow to balance the moving weight. Impact damage and internal wear may result if the valve body vibrates while internal parts attempt to remain stationary. This condition may be avoided by adequately supporting the piping system near the check valve or by damping vibration at its source. Of course, it is helpful to ensure that the check element opens fully, because flow forces at the disc-stop help to inhibit relative motion.

#### • Debris in Line Fluid

Debris in the flow stream can cause damage and performance problems in check and stop-check valves. Debris entrapped between the disc and seat may prevent full closure and lead directly to seat leakage. If hard particles or chips are in the debris, they may damage the seating surfaces and contribute to seat leakage even after they are flushed away. Debris caught between the disc and the body bore of a piston-lift check valve can cause the disc to jam and prevent full opening or closing. To ensure best check valve performance and seat tightness, line fluids should be kept as clean as practical. As noted before, tilting-disc check valves are particularly resistant to sticking or jamming, but they are no more resistant to seat damage than other types.

#### • Unsteady (Pulsating) Flow

An unsteady flow rate can lead to rapid check valve damage, particularly if the minimum flow during a cycle is not sufficient to hold the valve fully open. The valve may be damaged just because it does what a check valve is designed to do – open and close in response to changes in flow. As an example, a check valve installed too close to the outlet of a positive displacement pump may attempt to respond to the discharge of each cylinder. If the mean flow during a cycle is low, the disc may bounce off the seat repeatedly in a chattering action. If the mean flow is higher,

the disc may bounce on and off the full-open stop. Such pulsating flows may be difficult to predict. For example, a steam leak past the seat of an upstream stop valve may produce a “percolating” action in a line filled with condensate and cause a check valve to cycle. Such problems may only be discovered by preventive maintenance inspections.

#### • Vapor Pockets in Liquid Piping Systems

Unusual phenomena are sometimes observed in piping systems containing hot water that partially vaporizes downstream of a closed check valve. Vapor pockets at high points may collapse suddenly when the check valve opens (due to the start-up of a pump, for example). This collapse may be remote from the check valve and have no effect on the check valve performance. However, if a vapor pocket exists in the upper part of a piston-lift check or stop-check valve body (above the disc), the collapse may generate unbalanced forces in the direction of disc opening. Since the vapor offers little fluid resistance, rapid acceleration of the disc toward the fully open position may occur. In extreme cases, the disc or bonnet stops may be damaged due to impact. Such thermodynamic quirks are difficult to anticipate when designing a piping system and are sometimes as difficult to diagnose if they occur in an existing installation. Changes in piping arrangements or operating procedures may be necessary if severe problems occur. It is possible that similar problems may occur during low-pressure start-up operations in unvented liquid-piping systems.

## 1.4 Check Valve Performance

### 1.4.1 Check Valve Seat Tightness

Edward check valves are factory-tested with water in accordance with MSS SP-61 (Manufacturers Standardization Society of the Valve and Fittings Industry, Inc.) at an overseat pressure of 1.1 times the pressure ratings of the valve. While check valves are allowed leakage rates up to 40 ml/hr per unit of nominal valve size by MSS SP-61, Flowserve allows no more than 5% of this leakage for cast-steel valves and no visible leakage for forged-steel valves. Tilting-disc and forged-steel check valves are then tested again at a reduced pressure with allowable leakage rates which are less than the MSS SP-61 requirements.

Closed check valve closure elements (disc, ball, flapper, etc.) are acted on by a combination of forces produced by gravity, springs

(where applicable) and reversed differential pressure. While gravity and spring forces help to position the closure element into the substantially closed position, metal-to-metal seating check valves typically rely on pressure forces to produce the seating loads necessary for good seat tightness.

Some metal-seated check valves do not produce good seat tightness at low differential pressures, particularly when the pressure increases from zero. A threshold level of differential pressure is required to produce uniform metal-to-metal contact and restrict leakage to a reasonable rate. An even higher level is required to ensure that a valve meets leakage-rate criteria like those in MSS SP-61. Unfortunately, these levels of differential pressure are difficult to predict; they vary with valve type, condition and orientation (and with cleanliness of line fluid).

Tests of new valves in horizontal lines show that cast-steel inclined-bonnet and 90° bonnet piston-lift check and tilting-disc check valves seal off reasonably well at under 50 psi (3.4 bar) when differential pressure increases from zero. Small forged-steel ball and piston-lift check valves are less consistent, sometimes seating at less than 50 psi (3.4 bar) and sometimes requiring 250 psi (17 bar) or more. This “seating” action often occurs suddenly when the pressure forces shift the closure element into good metal-to-metal contact with the body seat, and leakage generally continues to decrease as the pressure is increased. Once seated, most valves seal well if pressure is reduced below the threshold required for initial seating, but the seat tightness with reducing pressure is also difficult to predict.

Some of the Edward check valves described in this catalog have been manufactured with “soft seats” to provide improved seat tightness at low differential pressures. This design feature includes an elastomeric or plastic sealing member on the valve closure element to supplement the basic metal-to-metal seating function. Since the design and material selection for these sealing members are very sensitive to pressure, temperature and compatibility with the line fluid, there are no standard, general-purpose, soft-seated valves. Consult Flowserve for further information about specific applications.

Foreign material in the flow medium is a major source of leakage problems in many valves. Because of the limited seating forces in check valves, dirt has a far greater effect on the tightness of these valves than other

types. Attention to cleanliness of the fluid is necessary where good check valve seat tightness is desired.

Incorrect sizing or misapplication of a check valve can also lead to leakage problems. Chattering of the closure element on its seat due to insufficient flow or pressure can cause damage to the seat or closure element and result in leakage.

In applications where check valve leakage is a problem, a stop-check valve may offer the solution. Stem load from a handwheel or actuator can provide the necessary seating force independent of pressure. Of course, the stem must be returned to the “open” position to allow flow in the normal direction. Consult Flowserve about applications that are usually sensitive to leakage.

A complete treatment of the subject of pressure surge and waterhammer is beyond the scope of this catalog, but some discussion is provided so that application engineers may appreciate the significance of the problem as it relates to check valves.

#### 1.4.2 Pressure Surge and Waterhammer

One part of the problem is that the terminology or jargon is not consistently used. For example, “waterhammer” or “steam hammer” is sometimes used to describe the implosion that occurs when water enters a hot, low-pressure region and causes a steam void to collapse. This has occurred in systems with a failed check valve, where the water came back from a large reverse flow through the check valve. However, the more common “waterhammer” problem associated with check valves occurs as a result of the check valve closing and suddenly terminating a significant reversed flow velocity. This problem is generally associated with valves handling water or other liquids. A similar pressure-surge phenomenon may be encountered with steam or gas, but it is generally much less serious with a compressible flow medium.

Waterhammer is a pressure surge produced by the deceleration of a liquid column, and it involves pressure waves that travel at close to the velocity of sound through the fluid. It is commonly illustrated in texts by an example involving rapid closure of a valve in a long pipe. For such a case, it can be shown that instantaneous closure of a valve in a room-temperature water line will produce an increase in pressure of about 50 psi (3.4 bar) above the steady-state pressure for every 1

ft/sec (0.30 m/sec) decrease in water velocity. Even if the valve does not close instantaneously, the same pressure increase would develop if the upstream pipe is long enough to prevent reflected pressure waves from reaching the valve before it closes. The waves of increasing pressure that are generated by the closing valve “reflect” from a constant-pressure reservoir or vessel, if present in the system, and return to the valve as inverted waves that decrease pressure. A solution to the “textbook problem” is to slow down the valve closure so that the reflected pressure waves attenuate the surge. However, this is not necessarily the best approach in the case of a check valve.

In a check valve, the fluid velocity is forward before the valve starts to close, but it reduces due to some system action (e.g., a pump is shut off). If the velocity reverses before the valve closes, a waterhammer surge will be produced by a conventional check valve that is nearly proportional to the magnitude of the maximum reversed velocity. Figure 10 provides curves illustrating flow transients associated with different types of systems and flow interruptions. The graphs illustrate velocity in the pipe, forward and reverse, versus time on arbitrary scales. The following discussions describe each of the curves:

- **Curve A** illustrates flow coast-down in a simple circulating loop, such as a cooling system, following switch-off of pump power. The momentum of the pump impeller and the fluid keeps the fluid going forward until it is decelerated and finally stopped by friction. There would be no need for a check valve to prevent reverse flow in this system, but one might be included to permit pump maintenance without draining other equipment. In normal operation of this system, the check valve could produce no waterhammer.

- **Curve B** illustrates an application with a pump feeding a high-pressure system with a fairly large volume. It might represent a boiler feed system of a pump feeding a high reservoir. In this case, assuming similar momentum in the pump and fluid, forward flow continues for a while after the pump is switched off, but the downstream pressure decelerates the flow more rapidly and then reverses its direction. Without a check valve, the reverse flow would increase and stabilize at some value, unless the downstream system pressure declined. In the illustration, the magnitude of the maximum reverse velocity is drawn less than the initial forward velocity, but it might be higher in some systems.

**Figure 10 - Flow Reversal Transients**

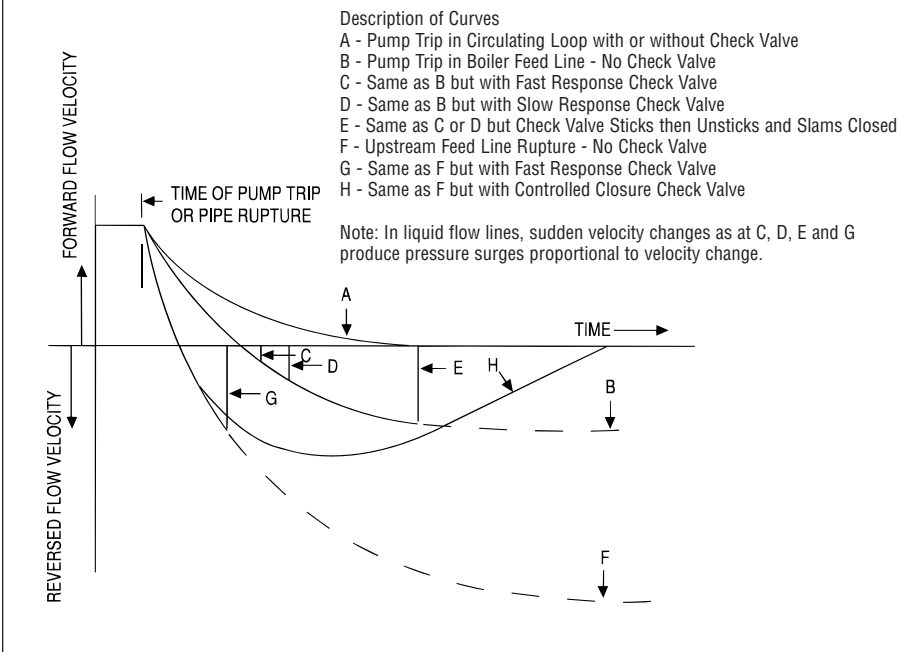

analyses and tests have shown that even the most rapid-responding conventional check valve could produce unacceptable waterhammer surges. This led to the development of the special controlled-closure check valve (CCCV—see Figure 11). Since high reverse velocities are inevitable, the CCCV solves the problem the way the “textbook problem” discussed above is solved—by closing slowly. The CCCV is a piston-lift check valve, but it has an internal dashpot that slows the closing speed of the valve. Closing speed depends on the rate at which water is squeezed out of the dashpot chamber, through flow paths that are sized for each application.

- **Curve H** illustrates the velocity variation in the pipe-rupture situation described for Curve F, but with a CCCV in the line. In this case, the maximum reverse velocity might even be higher than in Curve G, but it is decelerated back to zero slowly, allowing reflected reducing-pressure waves to minimize the resulting waterhammer surge. Figure 12 provides a comparison between a conventional check valve and a CCCV for a specific pipe-rupture situation. Note that the conventional check valve closes in 0.07 seconds as compared to 1.0 seconds for CCCV. As a result, the conventional check valve produced a surge of 3000 psi (207 bar) while the CCCV limits the surge to 600 psi (41 bar). These characteristics have been demonstrated in tests and can be duplicated in computer-based dynamic analysis simulations of specific valves and systems.

While the CCCV solves a special problem, even this sophisticated product does not fulfill the definition of an ideal check valve. By closing slowly, it allows significant reverse flow before it seats. This characteristic might be undesirable in common pump-discharge applications, because the reverse flow might have adverse effects on pumps or other equipment. Studies of systems designs sometimes show that fast-response check valves, such as the tilting-disc type, should be retained at pump discharge points where an upstream pipe rupture is unlikely, with CCCVs applied at locations where an upstream pipe rupture could cause serious consequences (e.g., in feedwater lines inside the containment vessel of a nuclear power plant).

In Curves C, D, E, and G of Figure 10, it may be noted that the final terminations of reverse velocity are shown as substantially vertical lines. This does not imply that the valve closes instantaneously. However, tests of

**Figure 11 - Controlled Closure Check Valve (CCCV)**

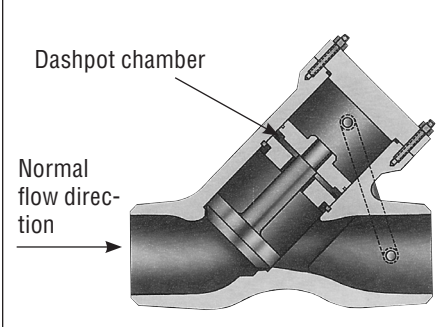

verse velocity (and a corresponding increase in waterhammer surge pressure).

- **Curve E** illustrates an accidental situation that might develop with a severely worn valve or a dirty system. If a check valve in the system described above should stick open, it might allow the reverse velocity to build up so as to approach that which would occur without a check valve. If the reverse flow forces should then overcome the forces that caused the sticking, the resulting valve stem could cause a damaging waterhammer surge.

- **Curve F** illustrates what might happen in the system described for Curve B if there were a major pipe rupture just upstream of the check valve. With free discharge through the open end, the flow would decelerate much more rapidly and, without a check valve, reach a much higher reverse velocity.

- **Curve G** shows the response of the system in Curve F if even a fast-response conventional check valve were to be used. With a flow deceleration this rapid, even a small lag may result in a very high reverse velocity to be arrested and a correspondingly high waterhammer surge.

Fortunately, it is not necessary to design every piping system with a check valve to cope with a pipe rupture. However, this requirement has emerged in some power-plant feedwater piping systems. Flowserve

- **Curve C** illustrates what would happen in the system described for Curve B with a fast-response check valve (e.g., a tilting-disc type) installed. As discussed in the Foreword to this guide, an “ideal” check valve would allow no reverse flow and would close exactly at the time the velocity curve passes through zero; there would be no waterhammer. A “real” check valve starts closing while the flow is still forward, but it lags the velocity curve. With fast response, it closes before a high reverse velocity develops, thus minimizing the waterhammer surge.

- **Curve D** illustrates the same system with a check valve that responds just a bit slower. It shows that just a small increase in check valve lag may allow a large increase in re-



**Figure 12 - Example Comparison of Closure Time and Surge Pressure Conventional vs Controlled Closure Check Valves**

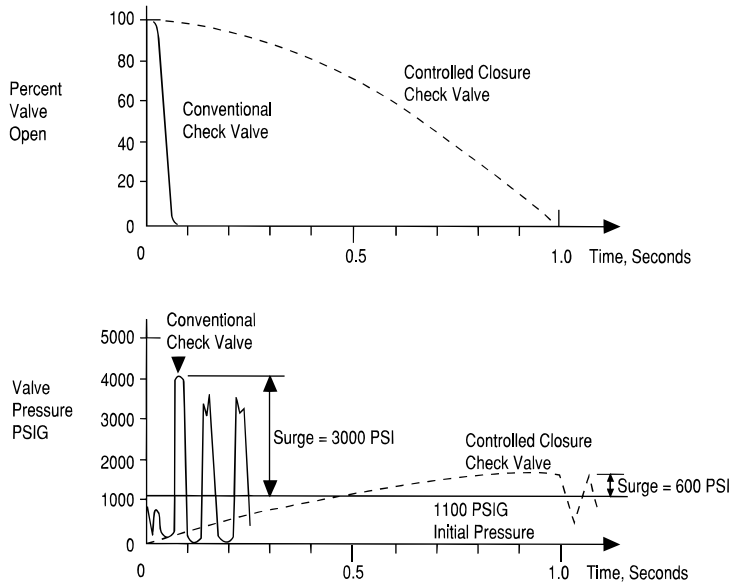

surge tends to be relatively insensitive to system pipe lengths.

In some check valve applications, problems have been observed due to a phenomenon that is related to waterhammer but not as widely recognized. When a high-pressure wave is produced on the downstream side of a check valve at closure, a reverse low-pressure wave is produced on the upstream side. If this low-pressure wave reduces the fluid pressure to below the saturation pressure of the fluid, a vapor pocket can form. This can be compared to a tensile failure of the flow stream, and it is sometimes referred to as column separation or column rupture. This vapor pocket is unstable and will collapse quickly, with an implosion that produces a high-pressure “spike.” It is possible for this pressure surge to exceed the one initially produced on the downstream of the check valve. Instrumented laboratory tests have shown that the upstream pressure spike sometimes causes the disc to reopen slightly and “bounce” off its seat once or twice. In very rare occasions, sometimes involving systems with multiple check valves, this characteristic has been known to amplify, leading to damaging pipe vibrations.

**Figure 13 - Reverse Flow in Conventional Swing Check Valve - Just Before Closing**

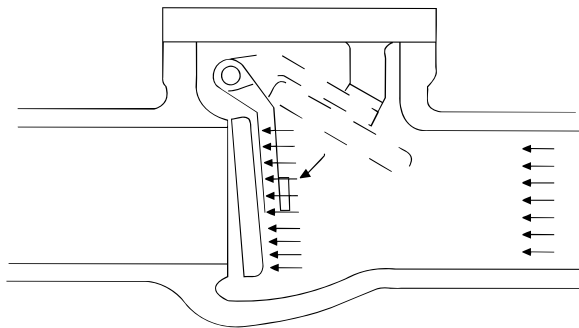

conventional check valves show that the reverse velocity in the pipe containing the valve does terminate almost instantaneously. This apparent contradiction may be understood by referring to Figure 13, which illustrates a check valve approaching the closed position with reverse flow (while the illustration depicts a swing check valve, the flow condition discussed here would be much the same with a poppet or disc in a conventional lift check or piston-lift check valve).

The key observation from Figure 13 is that a column of fluid follows the closure element at roughly the same velocity that the closure element has as it approaches its seating

surface in the valve body. While the valve may start to close while the flow velocity is still forward (see Figure 10), an undamped check valve has little effect on pipe flow during closure, and the disc velocity is about the same as the reverse flow velocity in the pipe at the instant just before closure. Since the disc is stopped substantially instantaneously when it makes metal-to-metal contact with the body seat, the reverse flow velocity in the pipe must also be arrested instantaneously. Because of this characteristic, the surge produced by the slam of a conventional check valve cannot be attenuated significantly by reflected reducing-pressure waves, and the

In summary, waterhammer can produce complex problems in check valve applications. Numerical solutions to these problems require sophisticated computer-based dynamic analyses of both the check valve and the fluid in the piping system. This catalog does not provide the methods for making such analyses; instead, the information in this section is intended to assist fluid-system designers in avoiding the problem.

Users who already have check valves in liquid flow lines that emit loud “slams” when they close should be aware that the noise is probably associated with pressure surges that could lead to fatigue problems in the valve, piping or other components. Where the existing check valve is a piston-lift check or stop-check valve, the solution could be to add a tilting-disc check valve in series with the existing check valve to gain the advantages of both valve types. Where the existing valve is a swing check valve, replacement by a tilting-disc check valve might be considered. See the section of this catalog titled Check Valve Types and Typical Uses (1.2.1) for a discussion of the strengths and weaknesses of the various valve types.

### 1.4.3 Check Valve Accessories and Special Features

Edward check valves can be provided with various accessories that are used to induce check-element motion (exercise) or indicate check-element position. Some of the features available are as follows:

- Visual disc-position indicator for tilting-disc check valve
- Electrical open/close position indicator for tilting-disc or cast-steel piston-lift check valve
- Manual or pneumatic actuator to partially open tilting-disc check valve under zero differential pressure
- CCCVs can be furnished with an injection port that allows the valve disc to be exercised by injecting water into the dashpot chamber when the valve is under a zero differential pressure.

### 1.4.4 Check/Stop-Check Valve Periodic Inspection and Preventive Maintenance

Periodic inspection and preventive maintenance of check and stop-check valves should be performed to ensure that the valves are operating properly. Bonnet-joint leakage and packing leakage on stop-check valves are easy to detect. Seat leakage of a check or

stop-check valve might be indicated by one of the following: a definite pressure loss on the high-pressure side of the valve; continued flow through an inspection drain on the low-pressure side; or, in hot water or steam lines, a downstream pipe that remains hot beyond the usual length of time after valve closure. Leakage of steam through a valve that is badly steam-cut has a whistling or sonorous sound. If the valve is only slightly steam-cut, however, leakage is identified by subdued gurgling or weak popping sounds. These sounds can often be heard through a stethoscope.

Excessive vibration, noise or humming coming from within a piston-lift check or stop-check valve indicates the possibility that the disc-piston assembly is wedged inside the body. Such sticking may be caused by uneven body-guide rib wear on the downstream side. Sticking rarely occurs with tilting-disc check valves.

“Tapping,” “thumping” or “rattling” noises detected from or near a check valve may indicate disc instability or cavitation. Instability could lead to rapid wear and possible valve failure. Audible cavitation is also detrimental. It may produce damage to the valve or the downstream piping. While the noise symptoms may be transmitted through the pipe from other equipment, prompt investigation is required if the check valve’s performance is critical to plant reliability.

No specific inspection/preventive maintenance schedule can be given to cover all check valves. It is suggested that small valves be sampled by size and type (there may be hundreds in a large installation). Schedules for audit of larger valves should consider the criticality of the valve service. It is wise to open some critical valves for internal inspection at intervals even if no suspicious noises are detected.

Where check valves are installed close to pumps, control valves, pipe fittings or other flow disturbances, they should have more frequent inspection [see the section of this catalog titled Adjacent Flow Disturbances (1.3.1)]. In addition, attention should be given to valves in installations with significant pipe vibration.

Users of this guide may wish to consider non-intrusive check valve monitoring methods as a supplement to periodic visual inspection and measurement of check valve internals. Noise and vibration, acoustic emission, ultrasonic and radiographic methods have been studied and demonstrated. EPRI Report No. NP 5479 provides an evaluation of the state of the art, but users are advised to obtain the most current information available on these emerging technologies.

If problems are found through any of the inspections discussed above, refer to section J: Maintenance.

## 2. Flow Performance

### 2.1 Choose the Best Valve Size for Your Service Conditions

The most economical valve is the valve correctly sized for the service flow conditions. Too small a valve will have a high-pressure drop and will incur expensive energy costs in service. Too large a valve wastes money at the time of purchase, and it may require excessive effort or an excessively large and expensive actuator for operation.

Piping-system designers sometimes optimize the size of valves and piping systems to minimize the sum of investment costs and the present value of pumping power costs. While this may not be practical for selection of every valve, it is a goal that should be kept in mind. This catalog provides information necessary to evaluate the various types and sizes of Edward valves for stop (isolation), stop-check and check valve applications.

In the case of stop-check and check valves, another consideration is that an oversized valve may not open completely. Obviously, if a valve is not fully open, the pressure drop will be increased. Also, if the disc operates too close to the seat, unsteady flow may cause flutter that may damage valve seats, discs or guides.

System designers should also address “turndown” if service conditions involve a broad range of flow rates (e.g., high flow in normal operation but low flow during start-up and standby conditions). For these reasons,

selection of check valves requires extra steps and care in calculations.

This section includes equations for the calculation of pressure drop, required flow coefficient, flow rate or inlet flow velocity. Procedures are also provided to check and correct for cavitation and flow choking. The equations in this section assume that the fluid is a liquid, a gas or steam. Two-component flow (e.g., slurries, oil-gas mixtures) is not covered by the equations. Consult FlowsERVE for assistance in evaluating such applications.

Tables in this section contain performance data for all Edward stop, stop-check and check valves. Flow coefficients and cavitation/choked-flow coefficients are given for all fully open Edward valves. In addition, for check and stop-check valves, the tables provide minimum pressure drop for full lift, crack-open pressure drop, and a novel “sizing parameter” that is helpful in selecting the proper valve size for each application.

**Caution:** Pressure drop, flow rate and check valve lift estimates provided by Edward calculation methods are “best estimate” values. Calculations are based on standard equations of the Instrument Society of America (ISA), flow rate and fluid data provided by the user, and valve flow coefficients provided by FlowsERVE.

Flow rate and fluid data are often design or best-estimate values. Actual values may differ from original estimates. Flow and check valve lift coefficients are based on laboratory testing. Valves of each specific type are tested, and results are extended to sizes not tested using model theory. This approach

is fundamentally correct, but there is some uncertainty because of geometric variations between valves.

These uncertainties prevent a guarantee with respect to valve pressure drop, flow rate and lift performance, but we expect results of calculations using FlowsERVE methods to be at least as accurate as comparable calculations involving flow and pressure drop of other piping system components.

#### 2.1.1 Pressure Drop, Sizing and Flow Rate Calculations – Fully Open Valves – All Types

This section is divided into two parts. The Basic Calculations section (2.2) covers most applications where pressure drops are not excessive. This is generally the case in most Edward valve applications, and the simple equations in this section are usually sufficient for most problems.

When the pressure drop across a valve is large compared to the inlet pressure, refer to the Corrections Required with Large Pressure Drops section (2.3). Various fluid effects must be considered to avoid errors due to choked flow of steam or gas—or flashing or cavitation of liquids. While use of these more detailed calculations is not usually required, it is recommended that the simple checks in that section always be made to determine if correction of the results of the Basic Calculations is necessary. With experience, these checks can often be made at a glance.

**Note:** In preliminary calculations using the following equations, a piping geometry factor,  $F_p = 1.0$ , may be used, assuming that the valve size is the same as the nominal pipe size. However, if an application involves installing a valve in a larger-sized piping system (or piping with a lower pressure rating than the valve, which will have a larger inside diameter), determine  $F_p$  from the Pipe Reducer Coefficients section when final calculations are made.

## 2.2 Basic Calculations

The following equations apply to FULLY OPEN gate and globe valves of all types. They also apply to stop-check and check valves if the flow is sufficient to open the disc completely. The Check Valve Sizing section (2.4) must be used to determine if a check valve is fully open and to make corrections if it is not.

The following simple methods may be used to calculate pressure drop, required flow coefficient, flow rate or inlet flow velocity for fully open Edward valves in the majority of applications. Always check Basic Calculations against the  $\Delta P/p_1$  criteria in Figure 14 to see if corrections are required. This check is automatically made when using the Proprietary Edward Valves Sizing Computer Program.

### 2.2.1 Pressure Drop

#### KNOWN:

Flow rate ( $w$  or  $q$ )

Fluid specific gravity ( $G$ ) or

Density ( $\rho$ )

For water, steam or air, see Figures 21-23

**FIND:** Valve flow coefficient ( $C_v$ ) from appropriate table

**CALCULATE:** Pressure drop ( $\Delta P$ )

When flow rate and fluid properties are known, determine required coefficients for a specific valve and calculate the pressure drop from the appropriate equation (see Nomenclature table for definition of terms and symbols):

#### Equation 1a (U.S.)

$$\Delta P = G \left( \frac{q}{F_p C_v} \right)^2$$

#### Equation 1b (metric)

$$\Delta P = G \left( \frac{q}{0.865 F_p C_v} \right)^2$$

#### Equation 1c (U.S.)

$$\Delta P = \frac{1}{\rho} \left( \frac{W}{63.3 F_p C_v} \right)^2$$

#### Equation 1d (metric)

$$\Delta P = \frac{1}{\rho} \left( \frac{W}{27.3 F_p C_v} \right)^2$$

If the resulting pressure drop is higher than desired, try a larger valve or a different type with a higher  $C_v$ . If the pressure drop is lower than necessary for the application, a smaller and more economical valve may be tried.

### 2.2.2 Required Flow Coefficient

#### KNOWN:

Flow rate ( $w$  or  $q$ )

Allowable pressure drop ( $\Delta P$ )

Fluid specific gravity ( $G$ ) or density ( $\rho$ )

For water, steam or air, see Figures 21-23

**CALCULATE:** Minimum required valve flow coefficient ( $C_v$ )

When the flow, fluid properties and an allowable pressure drop are known, calculate the required valve flow coefficient from the appropriate equation:

#### Equation 2a (metric)

$$C_v = \frac{q}{F_p} \sqrt{\frac{G}{\Delta P}}$$

#### Equation 2b (metric)

$$C_v = \frac{q}{0.865 F_p} \sqrt{\frac{G}{\Delta P}}$$

#### Equation 2c (U.S.)

$$C_v = \frac{W}{63.3 F_p \sqrt{\Delta P \rho}}$$

#### Equation 2d (metric)

$$C_v = \frac{W}{27.3 F_p \sqrt{\Delta P \rho}}$$

Results of these calculations may be used to select a valve with a valve flow coefficient that meets the required flow and pressure-drop criteria. Of course, valve selection also required prior determination of the right valve type and pressure class, using other sections of this catalog. The tabulated  $C_v$  of the selected valve should then be used in the appropriate pressure drop or flow-rate equation to evaluate actual valve performance. At this stage, the checks described in section

### Nomenclature (metric units in parentheses)

$C_v$	Valve flow coefficient
$d$	Valve inlet diameter, inches (mm)
$F_L$	Liquid pressure recovery coefficient, dimensionless
$F_p$	Piping geometry factor, dimensionless
$G$	Liquid specific gravity, dimensionless
$G_v$	Gas compressibility coefficient, dimensionless
$k$	Ratio of specific heats, dimensionless
$K_i$	Incipient cavitation coefficient, dimensionless
$\Delta P$	Valve pressure drop, psi (bar)
$\Delta P_{CO}$	Valve crack-open pressure drop, psi (bar)
$\Delta P_{FL}$	Minimum valve pressure drop for full lift-psi (bar)
$p_1$	Valve inlet pressure, psia (bar, abs)
$p_v$	Liquid vapor pressure at valve inlet temperature-psia (bar, abs)
$q$	Volumetric flow rate, U.S. gpm (m <sup>3</sup> /hr)

$R_F$	Ratio of sizing parameter to sizing parameter for full lift
$R_p$	Ratio of valve pressure drop to minimum pressure drop for full lift
$R_1$	Pressure drop ratio (gas or steam)
$R_2$	Pressure drop ratio (liquids)
SP	Valve sizing parameter
SP <sub>FL</sub>	Valve sizing parameter for full lift
$V$	Fluid velocity at valve inlet, ft/sec (m/sec)
$w$	Weight flow rate-lb/hr (kg/hr)
$x_t$	Terminal value of $\Delta P/p_1$ for choked gas or steam flow, dimensionless
$Y$	Gas expansion factor, dimensionless
$\rho$	Weight density of fluid at valve inlet conditions, lb/ft <sup>3</sup> (kg/m <sup>3</sup> )

Conversion factors are provided in the Conversion Factors section at the end of this catalog.

2.2 should be made to correct for effects of large pressure drops if required.

As discussed below under flow-rate calculations, the flow-coefficient equations assume that the allowable pressure drop is available for the valve. Piping pressure drop should be addressed separately.

**Caution:** In applications of stop-check or check valves, the results of these equations will apply only if the valve is fully open. Always use the methods given in the Check Valve Sizing section (2.4) to ensure that the valve will be fully open or to make appropriate corrections.

### 2.2.3 Flow Rate

**KNOWN:**

Pressure drop ( $\Delta P$ )  
 Fluid specific gravity (G) or density ( $\rho$ )  
 For water, steam or air, see Figures 21-23

**FIND:** Valve flow coefficient ( $C_v$ ) from appropriate table

**CALCULATE:** Flow rate (w or q)

When the fluid properties and an allowable pressure drop are known, determine required coefficients for a specific valve and calculate the flow rate from the appropriate equation:

**Equation 3a (U.S.)**

$$q = F_p C_v \sqrt{\frac{\Delta P}{G}}$$

**Equation 3b (metric)**

$$q = 0.865 F_p C_v \sqrt{\frac{\Delta P}{\rho}}$$

**Equation 3c (U.S.)**

$$w = 63.3 F_p C_v \sqrt{\Delta P \rho}$$

**Equation 3d (metric)**

$$w = 27.3 F_p C_v \sqrt{\Delta P \rho}$$

### 2.2.4 Inlet Flow Velocity

**KNOWN:**

Flow rate (w or q)  
 Fluid specific gravity (G) or density ( $\rho$ )  
 For water, steam or air, see Figures 21-23

**FIND:** Valve inlet diameter (d) from appropriate table

**CALCULATE:** Fluid velocity at valve inlet (V)

While not normally required for valve sizing and selection, the fluid velocity at the valve inlet may be calculated from the appropriate equation:

**Equation 4a (U.S.)**

$$V = \frac{0.409q}{d^2}$$

**Equation 4b (metric)**

$$V = \frac{354q}{d^2}$$

**Equation 4c (U.S.)**

$$V = \frac{0.0509w}{\rho d^2}$$

**Equation 4d (metric)**

$$V = \frac{354w}{\rho d^2}$$

These valve flow-rate calculations are used less frequently than pressure drop and flow-coefficient calculations, but they are useful in some cases.

**Caution:** These equations assume that the pressure drop used for the calculation is available for the valve. In many piping systems with Edward Valves, flow is limited by pressure drop in pipe and fittings, so these equations should not be used as a substitute for piping calculations.

Use of these flow-rate equations for stop-check and check valves is not recommended unless the allowable pressure drop is relatively high (e.g., over about 10 psi or 0.7 bar). At lower values of  $\Delta P$ , two or more different flow rates might exist, depending on whether or not the disc is fully open. Flow would vary depending on whether the pressure drop increased or decreased to reach the specified value.

*Note: If a specific pipe inside diameter is known, that diameter may be used as the "d" value in the equation above to calculate the fluid velocity in the upstream pipe.*

## 2.3 Corrections Required with Large Pressure Drops

While most Edward valves are used in relatively high-pressure systems and are usually sized to produce low-pressure drop at normal

flow rates, care is necessary to avoid errors (which may be serious in some cases) due to flow "choking" (or near-choking). Problems arise most often at off-design flow conditions that exist only during plant start-up, shutdown or standby operation.

Since steam and gas are compressible fluids, choking (or near-choking) may occur due to fluid expansion, which causes the fluid velocity to approach or reach the speed of sound in reduced-area regions. While liquids are normally considered to be incompressible fluids, choking may also occur with liquid flow due to cavitation or flashing. In each case, simple calculations can be made to determine if a problem exists. Relatively simple calculations are required to correct for these effects. In some cases, these calculations may require a change in the size of type of valve required for a specific application.

The flow parameters  $K_v$ ,  $F_p$  and  $x_p$  in the valve data tables assume that the valve is installed in pipe of the same nominal size. This is a fairly good assumption for preliminary calculations, but refer to the Pipe Reducer Coefficients section if there is a mismatch between valve and pipe diameters (also see instructions relative to  $F_p$  calculations in section 2.2) and make the appropriate corrections when final calculations are made.

*Note: Because large pressure drop problems are not encountered frequently, equations are presented in terms of weight flow rate (w) and density ( $\rho$ ) only. See the Conversion of Measurement Units section for converting other units of flow rate to weight flow rate.*

### 2.3.1 Gas and Steam Flow

#### 2.3.1.1 Pressure Drop

To determine if corrections are needed for compressible flow effects, use the data from the Basic Calculations to determine the ratio of the calculated pressure drop to the absolute upstream pressure:

**Equation 5**

$$R_1 = \frac{\Delta P}{p_1}$$

If the ratio  $R_1$  is less than the values in Figure 14, the results of the Basic Calculations will usually be sufficiently accurate, and further calculations are unnecessary.

**Figure 14 – Maximum  $\Delta P/P_1$  for use of Basic Calculations Without Correction**

Valve Type	Max. $\Delta P/P_1$
Gate	0.01
Inclined Bonnet Globe Angle Tilting-Disc Check	0.02
90° Bonnet Globe	0.05

If the pressure-drop ratio  $R_1$  exceeds that tabulated for the valve type under evaluation, the procedure described below should be used to check and correct for possible flow choking or near-choking.

(1) Calculate the gas compressibility coefficient:

**Equation 6 (U.S. or metric)**

$$G_y = \frac{0.467}{kX_T} \left( \frac{\Delta P}{p_1} \right)$$

Note: The  $\Delta P$  in this equation is the uncorrected value from the Basic Calculations. Values of  $x_T$  are given in valve data tables, and values of  $k$  are given in Figure 21.

(2) The next step depends on the value of  $G_y$  determined in equation 6:

• If  $G_y < 0.148$ , the flow is not fully choked. Read the value of  $Y$  from Figure 15 and calculate the corrected pressure drop:

**Equation 7 (U.S. or metric)**

$$\Delta P_c = \frac{\Delta P}{Y^2}$$

• If  $G_y \geq 0.148$ , the flow is choked. The desired flow cannot be achieved at the specified upstream pressure and will be limited to the choked flow rate given by:

**Equation 8a (U.S.)**

$$W_{\text{choked}} = 35.67 F_P C_V \sqrt{kX_T p_1 \rho}$$

**Equation 8b (metric)**

$$W_{\text{choked}} = 15.4 F_P C_V \sqrt{kX_T p_1 \rho}$$

• When flow is choked, the actual pressure drop cannot be calculated using valve flow calculations alone. It can be any valve greater than the following minimum value for choked flow:

**Equation 9 (U.S. or metric)**

$$\Delta P_{\text{min. choked}} \geq 0.714 kX_T p_1$$

• The only way to determine the pressure downstream of a valve with choked flow is to calculate the pressure required to force the choked flow rate through the downstream piping. This may be done with piping calculations (not covered by this catalog).

### 2.3.1.2 Flow Rate

When calculating the flow rate through a valve, the actual pressure drop is known, but the flow may be reduced by choking or near-choking.

To check for high pressure-drop effects, calculate  $R_1$ , the ratio of pressure drop to absolute upstream pressure (see equation 5 on previous page) noting that the pressure drop in this case is the known value.

(1) Flow rates determined using the Basic Calculations are sufficiently accurate if  $R_1$  is less than about twice the value tabulated in Figure 14 for the applicable valve type (higher because actual pressure drop is used in the ratio). In this case, no correction is necessary.

(2) When corrections for higher values of  $R_1$  are required, calculate the gas expansion factor directly from:

**Equation 10 (U.S. or metric)**

$$Y = 1 - 0.467 \left( \frac{\Delta P/p_1}{kX_T} \right)$$

(3) The calculation method to determine the flow rate depends on the calculated value of  $Y$  from equation (10):

• If  $Y$  is greater than 0.667 (but less than 1), the flow is not fully choked. Calculate the corrected flow rate as follows:

**Equation 11 (U.S. or metric)**

$$W_c = YW$$

• If  $Y$  is equal to or less than 0.667, the valve flow is choked, and the results of the Basic Calculations are invalid. The actual flow rate may be calculated from the equation for  $W_{\text{choked}}$  [(8a) or (8b)] above.

**Caution:** Choked or near-choked flow conditions may produce significant flow-induced noise and vibration. Prolonged operation with flow rates in this region may also cause erosion damage within a valve or in downstream piping, particularly if the flow condition involve “wet” steam. Edward valves tolerate these conditions well in services involving limited time periods during plant start-up, shutdown, etc., but consult Flowserve about applications involving long exposure to such conditions.

### 2.3.2 Liquid Flow – Cavitation and Flashing

The fluid pressure in high-velocity regions within a valve may be much lower than either

**Figure 15**

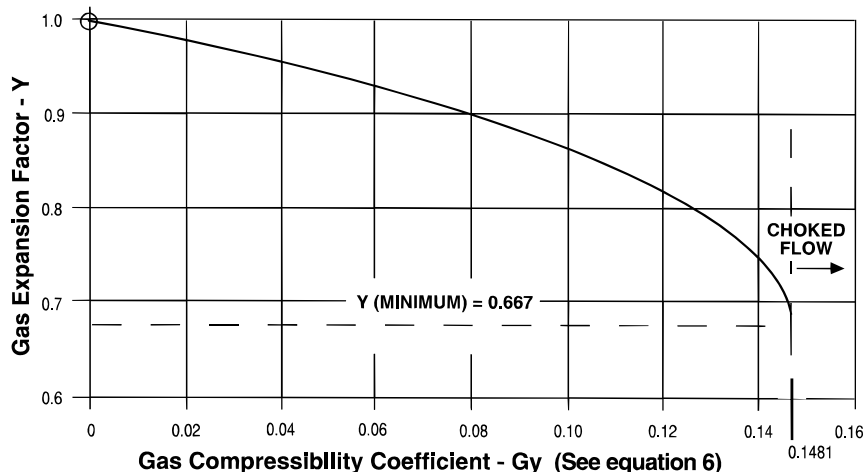

the upstream pressure or the downstream pressure. If the pressure within a valve falls below the vapor pressure ( $p_v$ ) of the liquid, vapor bubbles or cavities may form in the flow stream. Cavitation, flashing and choking may occur. Use the equations and procedures in this section to evaluate these phenomena.

Cavitation and flashing are closely related, and they may be evaluated by calculating a pressure-drop ratio that is slightly different from that used for gas or steam:

**Equation 12**

$$R_1 = \frac{\Delta P}{(p_1 - p_v)}$$

To evaluate a particular valve and application, find values of  $K_i$  and  $F_L$  from the appropriate valve-data table, find  $\dot{P}_v$  values for common liquids given in Figure 25, calculate  $R_2$ , and perform the following checks:

**(1) Cavitation** – the sudden and sometimes violent coalescence of the cavities back to the liquid state occurs when the downstream pressure (within the valve or in the downstream pipe) recovers to above the vapor pressure.

- If  $R_2 < K_i$ , there should be no significant cavitation or effect on flow or pressure drop. Results of the Basic Calculations require no correction.

- If  $R_2 > K_i$ , cavitation begins. If the ratio is only slightly greater than  $K_i$ , it may be detected as an intermittent “ticking” noise near the valve outlet, although pipe insulation may muffle this sound. This stage of cavitation is usually related to tiny vapor cavities that form near the center of vortices in the flow stream, and it generally produces neither damage nor effects on flow characteristics. However, as the pressure drop ratio  $R_2$  increases, the noise progresses to a “shh,” then a “roar.”

- If  $R_2 > (K_i + FL_2)/2$ , approximately, larger vapor cavities develop and the risk of cavitation damage (pitting) in the valve or downstream pipe may be a concern if this flow condition is sustained for significant periods of time. Noise may also pose a problem. Still, at this stage, there is usually no significant effect on valve flow characteristics. Results of the Basic Calculations require no correction.

As the pressure-drop ratio increases beyond this point, some valves suffer slight reductions in their  $C_v$  values, but there is no practical way of correcting pressure drop or flow calculations for this effect. Vibration

and noise increase, ultimately sounding like “rocks and gravel” bouncing in the pipe at about the point where flow becomes choked.

**(2) Flashing** – the persistence of vapor cavities downstream of the valve occurs when the pressure downstream of the valve remains below the vapor pressure.

- If  $R_2 > 1$ , flashing occurs, and the flow is choked due to vapor cavities in the flow stream.

**(3) Liquid choking** – A slightly different ratio may be used to predict the minimum pressure drop at choked flow conditions. Choking occurs due to vapor cavities near the minimum-area region in the flow stream when:

**Equation 13**

$$\frac{\Delta P}{(p_1 - 0.7p_v)} \geq F_L^2$$

Thus, the minimum pressure drop that will produce choked liquid flow is given by:

**Equation 14**

$$\Delta P \geq F_L^2 (p_1 - 0.7p_v)$$

Note that flow may be choked by either severe cavitation or flashing.

**2.3.2.1 Predicting Choked Flow Rate**

If the result of a Basic Calculation to determine pressure drop exceeds the value determined from equation (13), the Basic Calculation is invalid. The flow used for input cannot be obtained at the specified upstream pressure and temperature. In such a case, of if it is necessary to calculate liquid flow rate through a valve with high-pressure drop, the choked flow rate at specified conditions may be calculated from:

**Equation 15a (U.S.)**

$$W_{\text{choked}} = 63.3F_P C_v F_L \sqrt{\rho(p_1 - 0.7p_v)}$$

**Equation 15b (metric)**

$$W_{\text{choked}} = 27.3F_P C_v F_L \sqrt{\rho(p_1 - 0.7p_v)}$$

When flow is choked due to either cavitating or flashing flow, the actual pressure drop cannot be determined from valve calculations. It may be any value greater than the minimum value for choked flow [equation (14)]. As in the case of choked gas or steam flow, the pressure downstream of a valve

must be determined by calculating the pressure required to force the choked flow through the downstream piping. This may be done with piping calculations (not covered by this catalog).

- If the pressure drop from a Basic Calculation was used to determine flow rate, and the pressure drop exceeds the pressure drop of choked flow, the result is invalid. The corrected flow rate may be calculated from equation (15a) or (15b) above.

**2.4 Check Valve Sizing**

The most important difference between check (including stop-check) valves and stop valves, from a flow performance standpoint, is that the check valve disc is opened only by dynamic forces due to fluid flow. The preceding calculation methods for flow and pressure drop are valid only if it can be shown that the valve is fully open.

The primary purpose of this section is to provide methods to predict check valve disc opening and to make corrections to pressure-drop calculations if the valve is not fully open. These methods are particularly applicable to sizing valves for new installations, but they are also useful for evaluation of performance of existing valves.

In selecting a stop-check or check valve for a new installation, the first steps require selecting a proper type and pressure class. The Stop and Check Valve Applications Guide section of this catalog should be reviewed carefully when the type is selected, noting advantages and disadvantages of each type and considering how they relate to the requirements of the installation. Other sections of this catalog provide pressure ratings to permit selection of the required pressure class.

**2.4.1 Sizing Parameter**

The first step in evaluating a stop-check or check valve application is to determine the Sizing Parameter based on the system flow rate and fluid properties:

**Equation 16 (U.S. or metric)**

$$SP = \frac{W}{\sqrt{\rho}}$$

Tables in this section provide a Sizing Parameter for full lift ( $SP_{FL}$ ) for each Edward stop-check and check valve. The amount of opening of any check valve and its effect

on pressure drop can be checked simply as follows:

- If  $SP_{FL} < SP$ , the valve is fully open. Pressure drop may be calculated using the equations given previously for fully open valves (including corrections for large pressure drops if required).

- If  $SP_{FL} > SP$ , the valve is not fully open. A smaller size valve or another type should be selected if possible to ensure full opening. If that is not feasible, three additional steps are required to evaluate the opening and pressure drop of the valve under the specified service conditions.

*Note: EPRI Report No. NP 5479 (Application Guideline 2.1) uses a "C" factor to calculate the minimum flow velocity required to fully open a check valve. The sizing procedures in this catalog do not employ the "C" factor, but values are given in the valve data tables for readers who prefer to use the EPRI methods. Since the EPRI methods are based on velocity, a flow area is required as a basis. Valve Inlet Diameters presented in data tables are the basis for correlation between flow rate and velocity.*

### 2.4.2 Calculations for Check Valves Less Than Fully Open

If the preceding evaluation revealed an incompletely open check valve, perform the following additional calculations:

#### Calculate the flow-rate ratio:

##### Equation 17 (U.S. or metric)

$$R_F = \frac{SP}{SP_{FL}}$$

#### Determine the disc operating position:

Using the  $R_F$  value calculated above, determine the valve operating position from Figure 15 (forged-steel valves) or Figures 16-19 (cast-steel valves). Performance curve numbers for individual cast-steel stop-check and check valves are given in the tabulations with other coefficients. Evaluate the acceptability of the operating position based on recommendations in the Check Valve Applications Guide and in the specific sizing guidelines below.

#### Calculate the pressure drop:

Again using the  $R_F$  value calculated above, determine the pressure drop ratio  $R_P$  from Figures 15-19, and calculate the valve pressure drop at the partially open position:

##### Equation 18 (U.S. or metric)

$$\Delta P = R_P \Delta P_{FL}$$

Values for  $\Delta P_{FL}$  for all stop-check and check valves are given in Valve Tables 1 to 5 with other coefficients.

*Note: The values of the various valve coefficients given in the tabulations are based on testing of a substantial number of valves. Most are applicable to any line fluid, but those involving check valve lift are influenced by buoyancy. Tabulated values are based on reference test conditions with room-temperature water.  $SP_{FL}$  and  $\Delta P_{FL}$  are slightly higher in applications involving lower-density line fluids. Considering the expected accuracy of these calculations, the following corrections may be considered:*

- For water at any temperature and other common liquids – No correction required.
- For steam, air and other common gases at normal operating pressures and temperatures – Increase  $SP_{FL}$  by 7% and increase  $\Delta P_{FL}$  by 14%.

### 2.4.3 Sizing Guidelines

Considering the recommendations in the Check Valve Applications Guide section of this catalog and the calculation methods described above, the following specific steps are recommended for sizing check valves for optimum performance and service life (it is assumed that the check valve type and pressure class have already been selected before starting this procedure):

**(1) Constant flow rate** – If the application involves a substantially constant flow rate during all operating conditions, the check valve should be sized to be fully open. This may be accomplished by the following procedure:

- Calculate the check valve sizing parameter (SP) for the application from equation (15). Values of density for water, steam, and air are available in Figures 21-23.

If the flow rate is not given in lb/hr (or kg/hr), refer to the Conversion of Measurement Units section of this catalog to make the necessary calculation.

- Select the valve size with the next smaller  $SP_{FL}$  value from valve data tables (Tables 1-5). Make note of the  $C_v$ ,  $\Delta P_{CO}$ ,  $\Delta P_{FL}$ ,  $K_v$ ,  $F_L$  and  $x_1$  values for use in later calculations.

*Note: Preferably, there should be a good margin between SP and  $SP_{FL}$  to be sure the valve will be fully open. In the specific case of tilting-disc check valves, it is recommended that  $SP_{FL}$  be less than 0.83 (SP) to be sure that the disc is fully loaded against its stop (particularly if it is close to a flow disturbance).*

- Calculate the pressure drop using the Basic Calculation method in equation (1) and the  $C_{xx}$  value of the valve size selected above. Make the simple checks described above in section 2.2 (Corrections Required With Large Pressure Drops), and make appropriate corrections in necessary (this is rarely needed

for a valve sized for constant flow rate, but the check is desirable).

- Evaluate the pressure drop. If it is too high, a larger size or another check valve type should be tried. If it is lower than necessary for the application, a smaller and more economical valve (with a lower  $SP_{FL}$ ) may be evaluated with assurance that it would also be fully open.

- Evaluate the crack-open pressure drop ( $\Delta P_{CO}$ ) to be certain that the system head available at the initiation of flow will initiate valve opening. Note that, for some valves, the crack-open pressure drop exceeds the pressure drop for full lift. Preceding calculations might indicate no problem, but it is possible that a valve might not open at all in a low-head application (e.g., gravity flow).

**(2) Variable flow rate** – If the application involves check valve operation over a range of flow rates, additional calculations are necessary to ensure satisfactory, stable performance at the lowest flow rate without causing excessive pressure drop at the maximum flow condition. This required careful evaluation of specific system operating conditions (e.g., are the minimum and maximum flow rates normal operating conditions or infrequent conditions that occur only during start-up or emergency conditions?).

The following options should be considered in selecting the best stop-check or check valve size for variable flow applications:

- The best method, if practical, is to size the valve to be fully open at the minimum flow condition. This may be done by following the first two steps listed above for the constant flow-rate case, but using the minimum flow rate in the sizing parameter (SP) calculation.

The only difference is that the pressure-drop calculations and evaluations in the third and fourth steps must be repeated at normal and maximum flow rates. If the selected valve size is fully open at the minimum flow rate and has an acceptable pressure drop at the maximum flow condition, it should give good overall performance.

- Sometimes a change in valve type provides the best cost-effective solution for variable-flow applications (e.g., use a smaller Flite-Flow stop-check or check valve instead of a 90° bonnet type to provide full lift at the minimum flow condition, but a high  $C_v$  for low pressure drop at maximum flow).
- Operation at less than full lift may have to be considered.



**(3) Operation at less than full lift** – “High Turndown” applications sometimes exist on boilers and other process systems that must swing through periodic flow changes from start-up, to standby, to maximum, and back again. In such cases, calculations may not reveal any single valve that will offer a satisfactory compromise ensuring full lift and an acceptable pressure drop at both minimum and maximum flow conditions.

It may be acceptable to permit a check valve to operate at less than fully open at the minimum flow condition if such operation is infrequent or not expected to be sustained continuously for long periods. A valve may be sized by following the methods above using the lowest expected normal sustained flow rate in the sizing parameter (SP) calculation. Pressure drop at normal and maximum flow rates should then be calculated and evaluated.

The acceptability of valve operation at the minimum flow condition should be evaluated as follows:

- Calculate the sizing parameter (SP) at the minimum flow rate and the flow-rate ratio  $R_F$  from equation (17). The valve operating position (% open) should be determined from the proper performance curve (Figures 15-19).

**Caution:** Check valve operation at less than 25% opening is not recommended. Any check valve that operates for sustained periods at partial openings should be monitored or inspected periodically for evidence of instability or wear.

- If the minimum operating position is considered satisfactory, the pressure drop at the minimum flow condition may be calculated from equation (18), using the pressure-drop ratio ( $R_p$ ) determined from the proper performance curve.

**(4) Alternatives for high turndown applications** – If the preceding steps show that the range of flow rates is too large for any single standard check valve, consult Flowserve. Several alternatives may be considered:

- Either 90° bonnet or angle-type stop-check or piston-lift check valves may be furnished with a special disc with an extended “skirt” as illustrated in Figure 15A. This skirt increases flow resistance at low flow rates, producing additional lifting force to help prevent operation at small openings.

Of course, the skirt also reduces the  $C_v$  of the valve somewhat when it is fully open and increases pressure drop at maximum

flow. Nevertheless, a special disc sometimes solves difficult high turndown problems. A special disc also permits solution of some problems with existing valves that are “oversized.”

- A stop-check valve may be used with the stem lifted just enough to provide a positive stop for the disc at very low flows (e.g., short-term start-up conditions). The stem should be lifted with increasing flow rate to maintain the disc-stopping action while preventing excessive pressure drop. At normal flow rates, the stem can be lifted to its fully open position, permitting normal check valve function. The stem may be actuated manually for infrequent start-up operations, or a motor actuator may be furnished for convenience if large flow rate variations are expected to be frequent.

**Caution:** This arrangement could produce cavitation or flow-choking problems if the flow rate is increased substantially without lifting the valve stem to compensate.

- A small check or stop-check valve may be installed in parallel with a larger stop-check valve. The smaller valve may be sized for the minimum flow condition, and the larger stop-check may be held closed with the stem until the flow is sufficient to ensure adequate lift. If necessary, the stem on the larger valve may be opened gradually with increasing flow to maintain disc-stopping action as in the example above. The smaller valve may be allowed to remain open at higher flow rates or, if a stop-check type is used, it may be closed if preferred. Either or both valves may be manually actuated or furnished with a motor actuator for convenience.

## 2.5 Pipe Reducer Coefficient

The equations in the Flow Performance section of this catalog use a piping geometry factor,  $F_p$ , to account for the effect of pipe reducers attached directly to the valve. This permits the valve and pipe reducers to be treated as an assembly, i.e.,  $F_p C_v$  is the flow coefficient of the valve/pipe reducer combination. Then, the pressure drop in the flow equations is the pressure drop of the assembly.

This method is also applicable when valves are furnished with oversized ends to fit larger diameter pipe. It should also be used to evaluate line-size valves used in pipe with a lower pressure rating than the valve, because such pipe may have less wall thickness and a larger inside diameter than the valve inlet diameter given in the valve data tabulations.

This section provides equations for calculation of the piping geometry factor,  $F_p$ , which should be used even in Basic Calculations when there is a significant difference between the pipe diameter and valve inlet diameter (d).

In addition, other coefficients ( $K$ ,  $F_L$ ,  $X_T$ ) are affected by the presence of pipe reducers. Equations are also provided for correction of these terms, which are required only when evaluating significant valve-to-pipe diameter mismatch.

*Note: These equations apply only where the valve diameter is less than the connecting pipe diameter.*

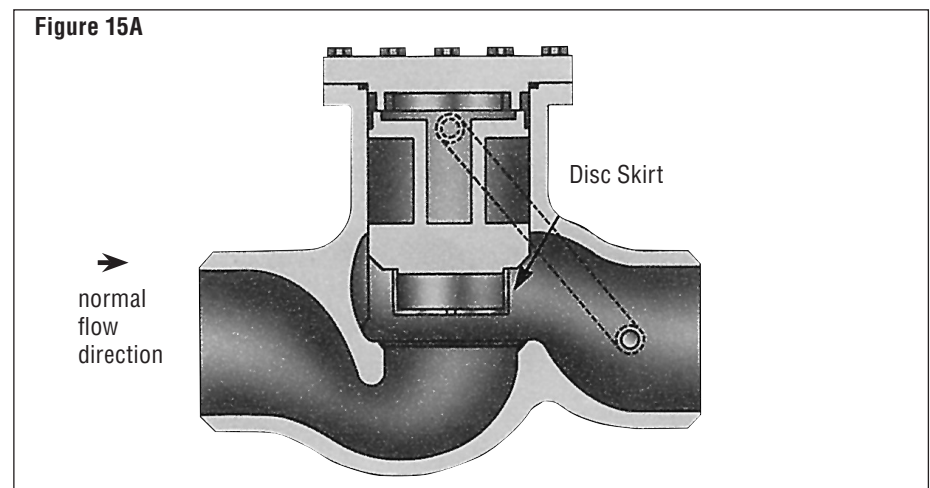

### 2.5.1 Pipe Geometry Factor

Calculate upstream loss coefficient:

**Equation 1-1 (U.S. or metric)**

$$K_1 = 0.5 \left[ 1 - \left( \frac{d}{D_1} \right)^2 \right]^2$$

Calculate downstream loss coefficient:

**Equation 1-2 (U.S. or metric)**

$$K_2 = \left[ 1 - \left( \frac{d}{D_2} \right)^2 \right]^2$$

Summation:

**Equation 1-3 (U.S. or metric)**

$$\sum K = K_1 + K_2$$

**Equation 1-4a (U.S.)**

$$F_p = \sqrt{\frac{1}{1 + \frac{\sum K}{890} \left( \frac{C_v}{d^2} \right)^2}}$$

**Equation 1-4b (metric)**

$$F_p = \sqrt{\frac{1}{1 + 486 \sum K \left( \frac{C_v}{d^2} \right)^2}}$$

*Note: If  $D_1$  and  $D_2$  are not the same, use of  $F_p$  calculated in this manner accounts for energy losses associated with flow contraction and expansion, and the pressure drop calculated using this factor represents energy loss. Bernoulli effects may cause a different static pressure change between upstream and downstream pipes.*

### 2.5.2 Other Coefficients

Correction of values of  $K_i$ ,  $F_L$  and  $x_T$  requires an initial calculation of a Bernoulli coefficient to account for static pressure change in the inlet reducer:

**Equation 1-5 (U.S. or metric)**

$$K_{B1} = 1 - \left( \frac{d}{D_1} \right)^4$$

Then, corrected values of each coefficient may be calculated, using the corresponding value from valve data tables as input:

**Equation 1-6a (U.S.)**

$$K_{ii} = \frac{1}{F_p^2 \left[ \frac{1}{K_i} + \left( \frac{K_1 + K_{B1}}{890} \right) \left( \frac{C_v}{d^2} \right)^2 \right]}$$

**Equation 1-6b (metric)**

$$K_{ii} = \frac{1}{F_p^2 \left[ \frac{1}{K_i} + 468 (K_1 + K_{B1}) \left( \frac{C_v}{d^2} \right)^2 \right]}$$

**Equation 1-7a (U.S.)**

$$F_{LL} = \frac{1}{F_p \sqrt{\frac{1}{F_L^2} + \left( \frac{K_1 + K_{B1}}{890} \right) \left( \frac{C_v}{d^2} \right)^2}}$$

**Equation 1-7b (metric)**

$$F_{LL} = \frac{1}{F_p \sqrt{\frac{1}{F_L^2} + 468 (K_1 + K_{B1}) \left( \frac{C_v}{d^2} \right)^2}}$$

**Equation 1-8a (U.S.)**

$$x_{TT} = \frac{x_T}{F_p^2 \left[ 1 + \frac{x_T (K_1 + K_{B1})}{1000} \left( \frac{C_v}{d^2} \right)^2 \right]}$$

**Equation 1-8b (metric)**

$$x_{TT} = \frac{x_T}{F_p^2 \left[ 1 + 416 x_T (K_1 + K_{B1}) \left( \frac{C_v}{d^2} \right)^2 \right]}$$

where:  $K_i$ ,  $F_L$  and  $x_T$  are values from valve data tables;  $K_{ii}$ ,  $F_{LL}$  and  $x_{TT}$  are corrected values for valve/reducer assembly.

### Nomenclature

$C_v$	valve flow coefficient. See Valve Reference Data.
$d$	valve-end inside diameter, inches, (mm). See Valve Reference Data.
$D_1$	inside diameter of upstream pipe, inches, (mm). See Pipe Data Section.
$D_2$	inside diameter of downstream pipe, inches, (mm). See Pipe Data Section.
$F_L$	liquid-pressure recovery coefficient, dimensionless*
$F_p$	piping-geometry factor, dimensionless
$K_1$	pressure-loss coefficient for inlet reducer, dimensionless
$K_2$	pressure-loss coefficient for outlet reducer, dimensionless
$K_{B1}$	pressure change (Bernoulli) coefficient for inlet reducer, dimensionless
$\sum K$	$K_1 + K_2$ , dimensionless
$K_i$	incipient-cavitation coefficient, dimensionless*
$x_T$	terminal value of $\Delta P/p_1$ for choked gas or steam flow, dimensionless

\*Double subscripts (e.g.  $K_{ii}$ ) represent values corrected for effects of pipe reducers.

**Table 1 – Edward Cast Steel Globe  
Flow Coefficients**

Black numerals are in U.S. customary units or dimensionless  
Colored numerals are in metric units

Size		Stop and Check Valves					Check Valve Coefficients					Perf. Curves Fig. 17			
NPS	DN	C <sub>v</sub>	F <sub>L</sub>	x <sub>T</sub>	K <sub>i</sub>	d	ΔP <sub>co</sub>	ΔP <sub>FL</sub>	SP <sub>FL</sub>	C					
<b>Class 900 (PN 150)</b> Figure No. 4016/4016Y, 4316Y Stop valves, 4006/4006Y, 4306Y Stop-Check valves, 4094/4094Y, 4394Y Check valves															
3	80	110	0.96	0.60	0.10	2.87	72.9	0.92	0.063	1.5	0.10	8510	964	53	4
4	100	200	0.97	0.60		3.87	98.2	1.3	0.090	2.3	0.16	19,500	2210	66	5
5	125	305	0.97	0.61		4.75	121	1.3	0.092	2.5	0.18	30,600	3470	69	4
6	150	530	0.81	0.42	0.07	5.75	146	1.2	0.085	1.5	0.10	41,500	4700	64	3
8	200	910	0.81	0.42		7.50	191	1.3	0.093	1.5	0.10	69,500	7870	63	2
10	250	1400	0.81	0.42		9.37	238	1.6	0.11	1.8	0.12	119,000	13,500	69	1
12	300	2000	0.81	0.42		11.12	282	1.8	0.12	2.1	0.14	182,000	20,600	75	2
14	350	2400	0.81	0.42		12.25	311	1.6	0.11	1.9	0.13	211,000	23,900	72	2
<b>Class 1500 (PN 260)</b> Figure No. 2016, 7516/7516Y Stop valves, 2006Y, 7506/7506Y Stop-Check valves, 2094Y, 7594/7594Y Check valves															
2.5	65	72	0.92	0.54	0.08	2.25	57.2	0.76	0.052	1.3	0.091	5230	592	53	5
3	80	110	0.89	0.51		2.75	69.9	0.92	0.063	1.5	0.10	8510	964	57	4
4	100	200	0.85	0.47		3.62	91.9	1.3	0.088	2.3	0.16	19,300	2190	75	5
5	125	300	0.83	0.44	0.07	4.37	111	1.2	0.080	2.2	0.15	28,600	3240	76	4
6	150	465	0.80	0.42		5.37	136	1.4	0.094	1.4	0.096	35,000	3960	62	2
8	200	790	0.81	0.42		7.00	178	1.6	0.11	1.4	0.097	59,300	6720	62	1
10	250	1250	0.81	0.42		8.75	222	1.5	0.10	1.4	0.100	93,900	10,600	63	1
12	300	1750	0.81	0.42		10.37	263	1.5	0.11	1.8	0.12	147,000	16,600	70	3
14	350	2100	0.81	0.42	11.37	289	1.7	0.12	2.1	0.14	190,000	21,500	75	3	

See note following section 2.4.1 for discussion of C factor.

## Figure 16 – Edward Cast Steel Globe Piston Lift Check Valve Performance Curves

Figure 16A

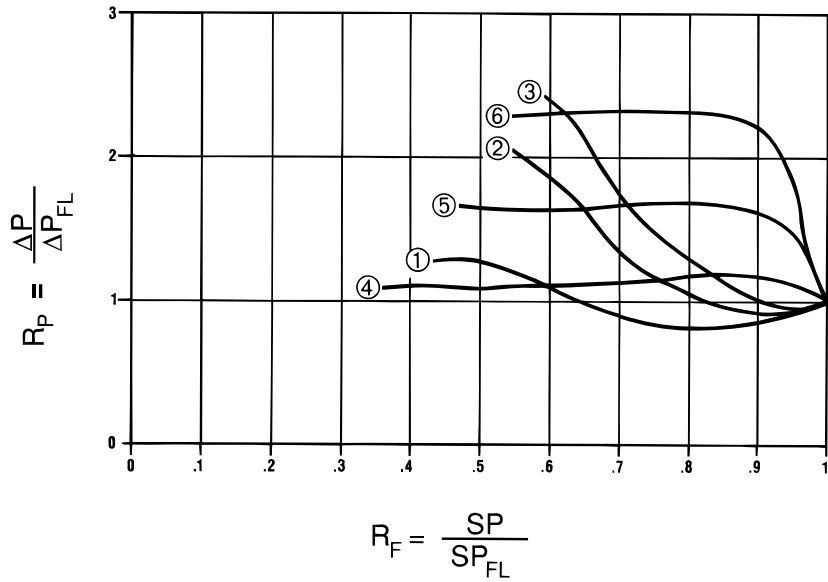
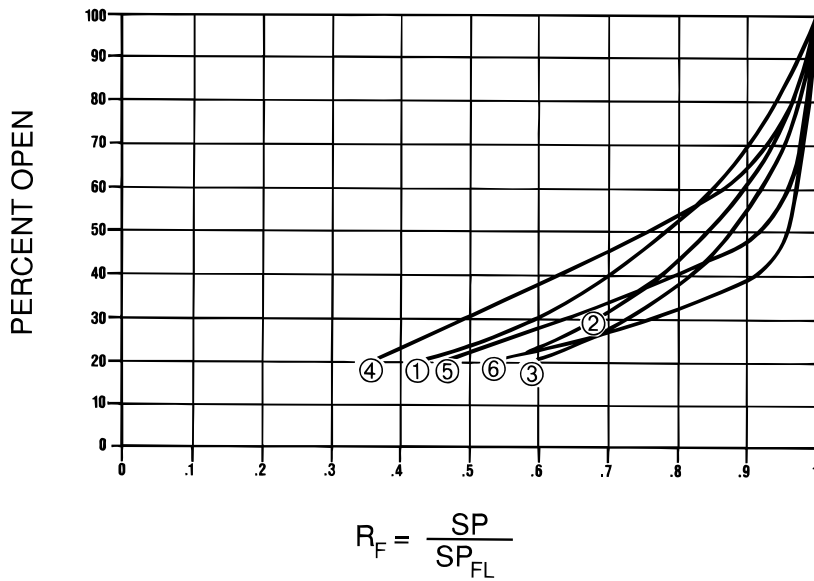

Figure 16B



**Table 2 – Edward Cast Steel Angle Valve Flow Coefficients**

Black numerals are in U.S. customary units or dimensionless  
Colored numerals are in metric units

Size		Stop and Check Valves					Check Valve Coefficient					Perf. Curves Fig. 17				
NPS	DN	C <sub>v</sub>	F <sub>L</sub>	x <sub>T</sub>	K <sub>i</sub>	d	ΔP <sub>co</sub>	ΔP <sub>FL</sub>	SP <sub>FL</sub>	C						
<b>Class 900 (PN 150)</b> Figure No. 4017/4017Y, 4317Y Stop valves, 4007/4007Y, 4307Y Stop-Check valves, 4095/4095Y, 4395Y Check valves																
3	80	180	0.62	0.24	0.08	2.87	72.9	0.92	0.063	0.64	0.044	8980	1020	56	5	
4	100	325	0.62	0.25		3.87	98.2	1.5	0.10	1.2	0.081	22,200	2510	75	5	
5	125	485	0.63	0.25		4.75	121	1.2	0.083	1.0	0.072	31,200	3530	70	5	
6	150	790	0.63	0.25		5.75	146	1.3	0.092	1.0	0.071	50,900	5770	78	3	
8	200	1350	0.63	0.25		7.50	190	1.4	0.099	1.0	0.071	86,600	9810	78	3	
10	250	2100	0.63	0.25		9.37	238	1.7	0.12	1.3	0.090	152,000	17,200	88	3	
12	300	2950	0.63	0.25		11.12	282	1.8	0.13	1.4	0.093	218,000	24,700	90	2	
14	350	3600	0.63	0.25		12.25	311	1.5	0.10	1.3	0.091	261,000	29,600	89	2	
16	400	6450	0.56	0.19		0.06	14.00	356	1.9	0.13	0.74	0.051	350,000	39,700	91	2
18	450	*	*	*			15.75	400	*	*	*	*	*	*	*	*
20	500	10,000	0.56	0.19	17.50		444	1.7	0.11	0.76	0.052	553,000	62,600	92	3	
24	600	14,500	0.56	0.19	21.00		533	2.6	0.18	1.1	0.073	940,000	106,000	109	3	

<b>Class 1500 (PN 260)</b> Figure No. 2017Y, 7517/7517Y Stop valves, 2007Y, 7507/7507Y Stop-Check valves, 2095Y, 7595/7595Y Check valves															
2.5	65	115	0.59	0.22	0.06	2.25	57.2	0.75	0.052	0.58	0.040	5560	630	56	6
3	80	180	0.57	0.21		2.75	69.9	0.92	0.063	0.64	0.044	8980	1020	60	5
4	100	320	0.55	0.19		3.62	91.9	1.50	0.10	1.20	0.081	22,000	2490	86	5
5	125	475	0.54	0.18		4.37	111	1.30	0.093	1.20	0.083	33,000	3740	88	5
6	150	690	0.63	0.25	0.08	5.37	136	1.50	0.10	1.00	0.069	43,800	4970	77	3
8	200	1150	0.63	0.25		7.00	178	1.60	0.11	0.99	0.068	73,900	8370	77	3
10	250	1850	0.63	0.25		8.75	222	1.60	0.11	1.20	0.083	127,000	14,400	85	3
12	300	2550	0.63	0.25		10.37	263	1.80	0.13	1.40	0.094	190,000	21,500	90	3
14	350	3100	0.63	0.25	0.06	11.37	289	1.70	0.12	1.30	0.091	225,000	25,500	89	3
16	400	5550	0.56	0.19		13.00	330	2.00	0.14	0.79	0.055	313,000	35,400	94	3
18	450	5350	0.54	0.19		14.62	371	2.00	0.14	0.86	0.059	313,000	35,400	75	3
20	500	*	*	*		*	16.37	416	*	*	*	*	*	*	*
24	600	*	*	*	*	19.62	498	*	*	*	*	*	*	*	*

See note following section 2.4.1 for discussion of C factor.

\* Consult Flowserve Edward Valves Sales Representative

**Figure 17 – Edward Cast Steel Angle Piston Lift Check Valve Performance Curves**

**Figure 17A**

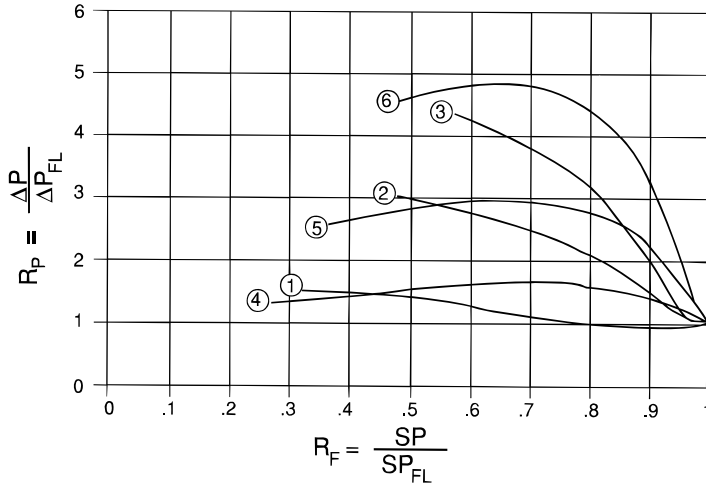

**Figure 17B**

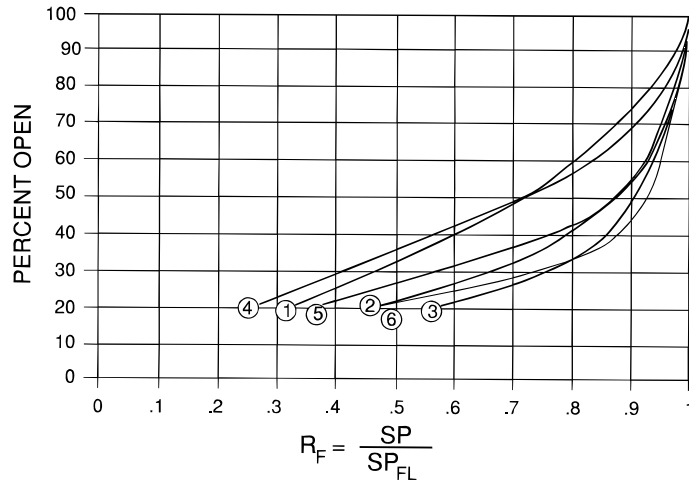

**Table 3 – Edward Cast Steel Flite-Flow® Stop and Stop-Check Valve Flow Coefficients**

Black numerals are in U.S. customary units or dimensionless  
Colored numerals are in metric units

Size		Stop and Check Valves						Check Valve Coefficients					Perf. Curves Fig. 17		
NPS	DN	C <sub>v</sub>	F <sub>L</sub>	x <sub>T</sub>	K <sub>i</sub>	d		ΔP <sub>co</sub>	ΔP <sub>FL</sub>	SP <sub>FL</sub>	C				
<b>Class 600 (PN 110)</b> Figure No. 614, 614Y, 714Y Stop valves; 602, 602Y, 702Y Stop-Check valves; 692, 692Y, 792Y Piston Lift Check valves															
3	80	295	0.52	0.20	0.08	3.00	76.2	0.8	0.06	0.44	0.030	12,400	1,400	70	4, 4
4	100	525	0.52	0.20	0.08	4.00	102	0.8	0.06	0.47	0.032	22,900	2,590	73	4, 4
6	150	1,200	0.52	0.20	0.08	6.00	152	0.7	0.05	0.53	0.037	54,500	6,170	77	4, 4
8	200	2,050	0.52	0.20	0.08	7.87	200	0.9	0.06	0.68	0.047	106,000	12,000	87	4, 4
10	250	3,100	0.52	0.20	0.08	9.75	248	1.0	0.07	0.85	0.059	182,000	20,600	98	4, 4
12	300	4,550	0.52	0.20	0.08	11.75	298	1.1	0.08	0.96	0.066	281,000	31,800	104	4, 4
14	350	4,550	0.52	0.20	0.08	11.75	298	1.1	0.08	0.96	0.066	281,000	31,800	104	4, 4
16	400	7,150	0.56	0.19	0.04	14.75	375	1.5	0.10	1.05	0.072	463,000	52,400	108	4, 4
20	500	11,000	0.52	0.20	0.08	18.25	484	1.4	0.10	0.96	0.066	677,000	76,700	104	1, 1
24	600	16,000	0.56	0.19	0.04	22.00	558	1.2	0.08	0.86	0.076	935,000	106,000	98	1, 2
<b>Class 900 (PN 150)</b> Figure No. 4014, 4014Y, 4314Y Stop valves; 4002, 4002Y, 4302Y Stop-Check valves; 4092, 4092Y, 4392Y Piston Lift Check valves															
3	80	270	0.52	0.02	0.08	2.87	72.9	0.9	0.06	0.52	0.036	12,400	1,400	77	4, 4
4	100	490	0.52	0.02	0.08	3.87	98.2	0.9	0.06	0.53	0.037	22,600	2,550	77	4, 4
6	150	1,100	0.52	0.02	0.08	5.75	146	0.7	0.05	0.50	0.034	48,500	5,490	75	4, 4
8	200	1,850	0.52	0.02	0.08	7.50	191	0.8	0.06	0.65	0.045	94,200	10,700	85	4, 4
10	250	2,900	0.52	0.02	0.08	9.37	238	1.0	0.07	0.84	0.058	167,000	18,900	97	4, 4
12	300	4,050	0.52	0.02	0.08	11.12	282	1.1	0.08	0.93	0.064	248,000	28,100	102	4, 4
14	350	4,050	0.52	0.02	0.08	11.12	282	1.1	0.08	0.93	0.064	248,000	28,100	102	4, 4
16	400	6,450	0.52	0.02	0.08	14.00	356	1.3	0.09	1.09	0.075	426,000	48,200	111	4, 4
<b>Class 1500 (PN 260)</b> Figure No. 2014Y, 7514Y Stop valves; 2002Y, 7502Y Stop-Check valves; 2092Y, 7592Y Check valves															
3	80	270	0.52	0.20	0.08	2.87	72.9	1.0	0.07	0.51	0.035	12,200	1,380	75	4, 4
4	100	425	0.52	0.20		3.62	91.9	1.0	0.07	0.62	0.043	21,200	2,400	82	4, 4
6	150	950	0.61	0.23		5.37	136	1.3	0.09	0.73	0.050	51,200	5,800	90	1, 3
8	200	1,600	0.61	0.23		7.00	178	1.5	0.10	0.74	0.051	87,800	9,940	91	1, 2
10	250	2,500	0.61	0.23		8.75	222	1.5	0.10	0.89	0.061	150,000	17,000	100	1, 2
12	300	3,550	0.61	0.23	0.05	10.37	263	1.7	0.12	1.01	0.070	225,000	25,500	107	1, 2
14	350	3,550	0.59	0.22		10.37	263	1.7	0.12	1.01	0.070	225,000	25,500	106	1, 2
16	400	5,550	0.61	0.23		13.00	330	1.8	0.12	1.09	0.075	366,000	41,500	110	1, 2
18	450	5,550	0.59	0.22		13.00	330	1.8	0.12	1.09	0.075	366,000	41,500	110	1, 2
20	500	8,800	0.61	0.23		16.37	416	2.2	0.15	1.46	0.101	673,000	76,200	128	1, 2
24	600	8,800	0.59	0.23	0.06	16.37	416	2.3	0.16	*	*	*	*	*	*

See note following section 2.4.1 for discussion of C factor.

\* Consult Flowserve Edward Valves Sales Representative.

**Figure 18 – Cast Steel Flite-Flow® Piston Lift Check Valve Performance Curves**

**Figure 18A**

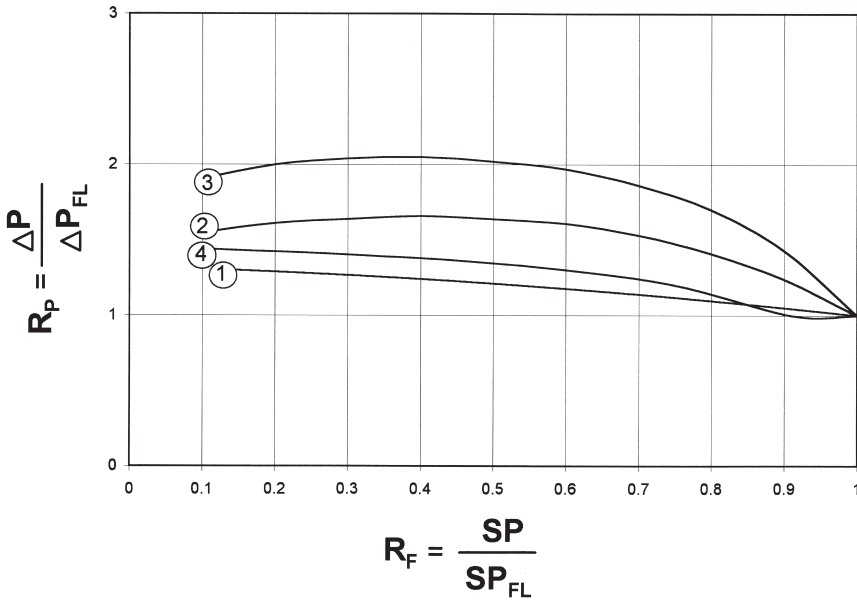

**Figure 18B**

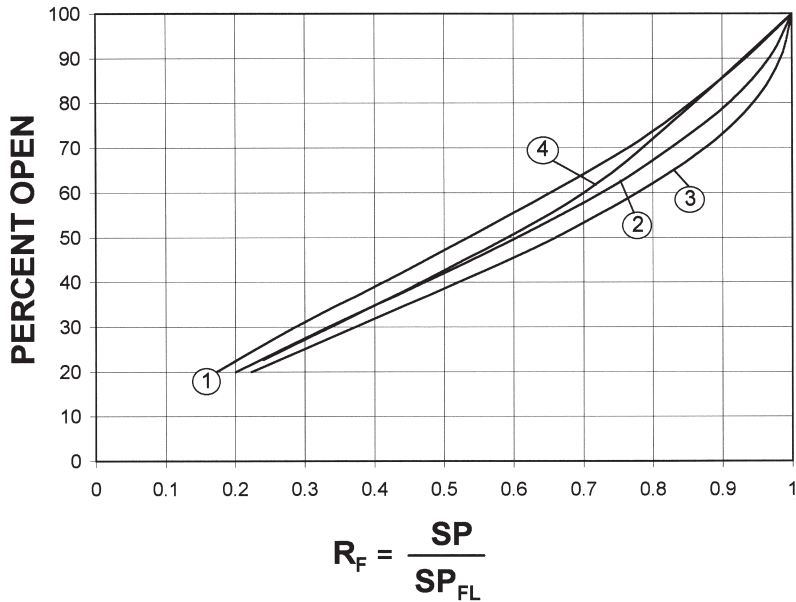



**Table 4 – Edward Cast Steel Tilting-Disc check Valve Flow Coefficients<sup>1</sup>**

Black numerals are in U.S. customary units or dimensionless  
Colored numerals are in metric units

Size		Check Valve Flow Coefficients					Check Valve Coefficients					Perf. Curves Fig. 20
NPS	DN	C <sub>v</sub>	F <sub>L</sub>	x <sub>T</sub>	K <sub>i</sub>	d	ΔP <sub>FL</sub>	SP <sub>FL</sub>	C			

**Class 600 (PN 110) Figure No. 670Y, 770Y**

6	150	1110	0.57	0.20	0.05	6.00	152	0.80	0.055	62,300	7,060	88	1
8	200	1850	0.57	0.20		7.87	200	1.0	0.069	115,000	13,000	95	1
10	250	2850	0.57	0.20		9.75	248	1.1	0.076	187,000	21,200	100	1
12	300	4100	0.57	0.20		11.75	298	1.2	0.083	285,000	32,300	105	1
14	350	4050	0.56	0.20		12.87	327	1.2	0.083	285,000	32,300	88	1
16	400	6500	0.57	0.20		14.75	375	1.4	0.097	481,000	54,500	113	1
18	450	8100	0.57	0.20		16.50	419	1.5	0.10	622,000	70,500	116	1
20	500	9950	0.57	0.20		18.25	464	1.6	0.11	786,000	89,000	120	1

**Class 900 (PN 150) Figure No. 970Y, 4370Y**

2.5	65	195	0.44	0.12	0.02	2.25	57.2	1.0	0.069	12,200	1,380	123	1
3	80	245	0.57	0.20	0.05	2.87	72.9	0.60	0.041	12,200	1,380	75	1
4	100	215	0.59	0.23		3.87	98.2	0.80	0.055	12,200	1,380	41	1
6	150	990	0.57	0.20		5.75	146	0.80	0.055	56,800	6,430	87	1
8	200	1700	0.57	0.20		7.50	190	0.80	0.055	97,000	11,000	88	2
10	250	2400	0.56	0.20		9.37	238	0.90	0.062	145,000	16,400	84	2
12	300	3450	0.56	0.20		11.12	282	1.1	0.076	233,000	26,400	96	1
14	350	3300	0.56	0.20		12.25	311	1.3	0.090	233,000	26,400	79	1
16	400	4950	0.56	0.20		14.00	356	1.3	0.090	360,000	40,800	94	1
18	450	4700	0.57	0.21	15.75	400	1.5	0.10	360,000	40,800	74	1	
20	500	9150	0.57	0.20	17.50	444	1.2	0.083	713,000	80,800	119	1	

**Class 1500 (PN 260) Figure No. 1570Y, 2070Y**

2.5	65	195	0.44	0.12	0.02	2.25	57.2	1.0	0.069	12,200	1,380	123	1
3	80	245	0.52	0.17	0.05	2.75	69.9	0.60	0.041	12,200	1,380	82	1
4	100	225	0.57	0.22		3.62	91.9	0.70	0.048	12,200	1,380	47	1
6	150	970	0.51	0.16		5.37	136	0.90	0.062	56,800	6,430	100	1
8	200	1650	0.51	0.16		7.00	178	0.90	0.062	97,000	11,000	101	2
10	250	2400	0.54	0.18		8.75	222	0.90	0.062	145,000	16,400	96	2
12	300	3450	0.53	0.17		10.37	263	1.1	0.076	233,000	26,400	110	1
14	350	3400	0.56	0.20		11.37	289	1.2	0.083	233,000	26,400	92	1
16	400	5050	0.57	0.20		13.00	330	1.3	0.090	360,000	40,800	108	1
18	450	4900	0.56	0.20	14.62	371	1.4	0.097	360,000	40,800	86	1	
24	600	10,500	0.56	0.20	19.62	498	1.5	0.10	824,000	93,400	109	1	

See note following section 2.4.1 for discussion of C factor.

<sup>1</sup> Crack open pressure drop ΔP<sub>co</sub> values are generally less than 0.25 psi (0.01 bar).

**Figure 19 – Tilting-Disc Check Valve Performance Curves**

**Figure 19A**

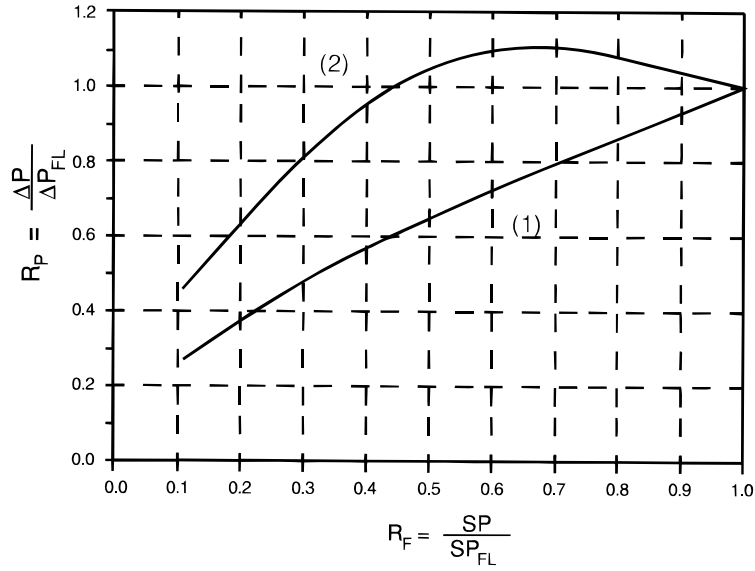

**Figure 19B**

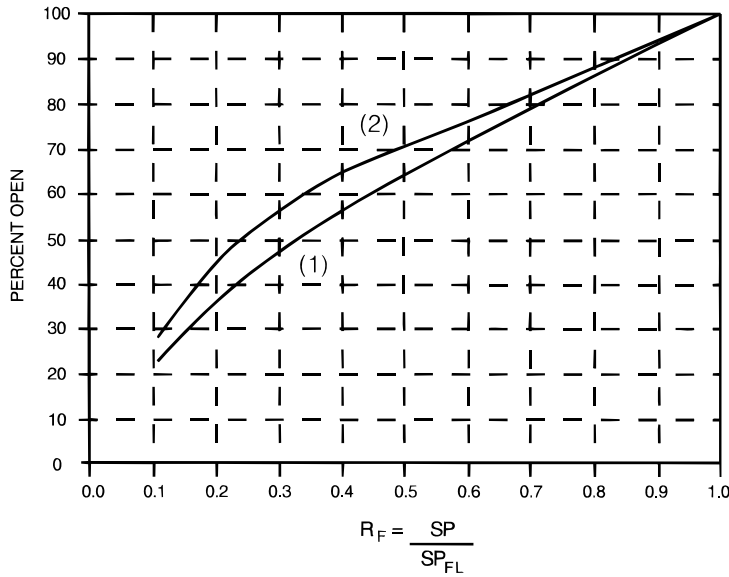

**Table 5 – Edward Cast Steel Equiwedge® Gate Valve Flow Coefficients**

Black numerals are in U.S. customary units or dimensionless  
Colored numerals are in metric units

Regular Port Gate Valves							
Size		C <sub>V</sub>	F <sub>L</sub>	X <sub>T</sub>	K <sub>i</sub>	d	
NPS	DN						

**Class 600 (PN 110) Figure No. 1611/ 1611Y, 1711Y Stop valves**

2.5	65	380	0.77	0.25	0.02	2.50	63.5
3.0	80	610	0.44	0.10	0.02	3.00	76.2
4.0	100	1250	0.41	0.08	0.03	4.00	102
6.0	150	3250	0.40	0.07	0.02	6.00	152
8.0	200	5300	0.35	0.06	0.02	7.87	200
10.0	250	8550	0.34	0.06	0.01	9.75	248
12.0	300	12,000	0.31	0.05	0.01	11.75	298
14.0	350	14,000	0.32	0.05	0.01	12.87	327
16.0	400	18,500	0.32	0.05	0.01	14.75	375
18.0	450	25,500	0.30	0.05	0.01	16.50	419
20.0	500	30,500	0.31	0.05	0.01	18.25	464
22.0	550	36,500	0.30	0.05	0.01	20.12	511
24.0	600	46,500	0.30	0.05	0.01	22.00	559
26.0	650	53,500	0.30	0.05	0.01	23.75	603
28.0	700	62,500	0.29	0.04	0.01	25.50	648
—	—	—	—	—	—	—	—
—	—	—	—	—	—	—	—

Venturi Port Gate Valves							
Size		C <sub>V</sub>	F <sub>L</sub>	X <sub>T</sub>	K <sub>i</sub>	d	
NPS	DN						

**Class 600 (PN 110) Figure No. 1611BY, 1711BY Stop valves**

—	—	—	—	—	—	—	—
—	—	—	—	—	—	—	—
—	—	—	—	—	—	—	—
—	—	—	—	—	—	—	—
8x6x8	200x150x200	2650	0.33	0.07	0.03	7.87	200
10x8x10	250x200x250	4500	0.32	0.07	0.02	9.75	248
12x10x12	300x250x300	7100	0.32	0.06	0.02	11.75	298
14x12x14	350x300x350	9900	0.32	0.06	0.02	12.87	327
16x14x16	400x350x400	12,000	0.31	0.06	0.02	14.75	375
18x16x18	450x400x450	17,500	0.29	0.05	0.01	16.50	419
20x18x20	500x450x500	22,000	0.30	0.06	0.02	18.25	464
22x20x22	550x500x550	29,000	0.28	0.05	0.01	20.12	511
24x20x24	600x500x600	24,500	0.30	0.06	0.02	22.00	559
26x22x26	650x550x650	30,000	0.30	0.06	0.02	23.75	603
28x24x28	700x600x700	40,500	0.29	0.05	0.01	25.50	648
30x26x30	750x650x750	46,500	0.29	0.05	0.01	27.37	695
32x28x32	800x700x800	52,000	0.30	0.05	0.01	29.25	743

**Table 5 (continued) – Edward Cast Steel Equiwedge® Gate Valve Flow Coefficients**

Black numerals are in U.S. customary units or dimensionless  
Colored numerals are in metric units

Regular Port Gate Valves						
Size		C <sub>V</sub>	F <sub>L</sub>	X <sub>T</sub>	K <sub>i</sub>	d
NPS	DN					

**Class 900 (PN 150) Figure No. 1911/ 1911Y, 14311Y Stop valves**

2.5	65	380	0.63	0.17	0.02	2.25	57.2
3.0	80	455	0.44	0.11	0.03	2.87	72.9
4.0	100	990	0.42	0.09	0.02	3.87	98.2
6.0	150	2350	0.41	0.09	0.02	5.75	146
8.0	200	4200	0.37	0.07	0.02	7.50	190
10.0	250	6250	0.40	0.08	0.02	9.37	238
12.0	300	9500	0.36	0.07	0.02	11.12	282
14.0	350	12,000	0.35	0.06	0.02	12.25	311
16.0	400	15,000	0.35	0.06	0.02	14.00	356
18.0	450	19,500	0.33	0.06	0.02	15.75	400
20.0	500	26,000	0.35	0.06	0.02	17.50	444
22.0	550	28,000	0.38	0.07	0.02	19.25	489
24.0	600	38,000	0.32	0.05	0.01	21.00	533
26.0	650	45,000	0.32	0.05	0.01	22.75	578
28.0	700	52,500	0.31	0.05	0.01	24.50	622
—	—	—	—	—	—	—	—
—	—	—	—	—	—	—	—

**Class 1500 (PN 260) Figure No. 11511/11511Y, 12011Y Stop valves**

2.5	65	305	0.78	0.26	0.02	2.25	57.2
3.0	80	420	0.52	0.14	0.03	2.75	69.9
4.0	100	760	0.47	0.12	0.03	3.62	91.9
6.0	150	1650	0.54	0.15	0.04	5.37	136
8.0	200	3150	0.48	0.12	0.03	7.00	178
10.0	250	5500	0.40	0.08	0.02	8.75	222
12.0	300	6850	0.42	0.09	0.02	10.37	263
14.0	350	9700	0.40	0.08	0.02	11.37	289
16.0	400	12,000	0.39	0.08	0.02	13.00	330
18.0	450	15,000	0.37	0.07	0.02	14.62	371
20.0	500	18,500	0.37	0.07	0.02	16.37	416
22.0	550	23,000	0.37	0.07	0.02	18.00	457
24.0	600	27,000	0.37	0.08	0.02	19.62	498
—	—	—	—	—	—	—	—
—	—	—	—	—	—	—	—

Venturi Port Gate Valves						
Size		C <sub>V</sub>	F <sub>L</sub>	X <sub>T</sub>	K <sub>i</sub>	d
NPS	DN					

**Class 900 (PN 150) Figure No. 1911BY, 14311BY Stop valves**

—	—	—	—	—	—	—	—
—	—	—	—	—	—	—	—
—	—	—	—	—	—	—	—
—	—	—	—	—	—	—	—
8x6x8	200x150x200	2000	0.37	0.09	0.03	7.50	190
10x8x10	250x200x250	3500	0.35	0.08	0.02	9.37	238
12x10x12	300x250x300	5950	0.35	0.08	0.02	11.12	282
14x12x14	350x300x350	7700	0.39	0.09	0.03	12.25	311
16x14x16	400x350x400	10,000	0.35	0.07	0.02	14.00	356
18x16x18	450x400x450	14,000	0.32	0.06	0.02	15.75	400
20x18x20	500x450x500	18,000	0.32	0.06	0.02	17.50	444
22x20x22	550x500x550	25,000	0.31	0.06	0.02	19.25	489
24x20x24	600x500x600	23,000	0.31	0.06	0.02	21.00	533
26x22x26	650x550x650	28,000	0.31	0.06	0.02	22.75	578
28x24x28	700x600x700	33,500	0.31	0.06	0.02	24.50	622
30x26x30	750x650x750	38,000	0.32	0.06	0.02	26.25	667
32x28x32	800x700x800	48,000	0.29	0.05	0.01	28.00	711

**Class 1500 (PN 260) Figure No. 11511BY, 12011BY Stop valves**

—	—	—	—	—	—	—	—
—	—	—	—	—	—	—	—
—	—	—	—	—	—	—	—
—	—	—	—	—	—	—	—
8x6x8	200x150x200	1650	0.43	0.12	0.04	7.00	178
10x8x10	250x200x250	2950	0.41	0.11	0.03	8.75	222
12x10x12	300x250x300	4500	0.40	0.10	0.03	10.37	263
14x12x14	350x300x350	7050	0.37	0.08	0.02	11.37	289
16x14x16	400x350x400	8700	0.37	0.08	0.02	13.00	330
18x16x18	450x400x450	11,000	0.37	0.08	0.02	14.62	371
20x18x20	500x450x500	13,500	0.36	0.08	0.02	16.37	416
22x20x22	550x500x550	18,000	0.34	0.07	0.02	18.00	457
24x20x24	600x500x600	17,000	0.35	0.07	0.02	19.62	498
26x22x26	650x550x650	20,500	0.35	0.07	0.02	21.25	540
28x24x28	700x600x700	24,000	0.36	0.08	0.02	23.00	584

**Table 6 – Edward Forged Steel Hermavalve® Flow Coefficients**

Black numerals are in U.S. customary units or dimensionless  
Colored numerals are in metric units

NPS	DN	Regular Port Hermavalves Fig. No. 15004/15104, 15008/15108, 16004, 16008				Reduced Port Hermavalves Fig. No. 15014/15114, 15018/15118, 16014, 16018				d	
		C <sub>v</sub>	F <sub>L</sub>	X <sub>T</sub>	K <sub>i</sub>	C <sub>v</sub>	F <sub>L</sub>	X <sub>T</sub>	K <sub>i</sub>		
0.05	15	4.9	0.46	0.31	0.07	—	—	—	—	0.464	11.8
0.75	20	6.1	0.52	0.36	0.09	—	—	—	—	0.612	15.5
1.00	25	11	0.55	0.38	0.10	6.1	0.51	0.36	0.09	0.815	20.7
1.50	40	32	0.62	0.39	0.13	11	0.53	0.37	0.09	1.338	34.0
2.00	50	50	0.68	0.40	0.15	32	0.57	0.37	0.11	1.687	42.8
2.50	65	—	—	—	—	50	0.59	0.37	0.12	2.125	54.0

**Table 7 – Forged Steel Univalve®  
Flow Coefficients**

Black numerals are in U.S. customary units or dimensionless  
Colored numerals are in metric units

Size		Stop and Check Valves					Check Valves* with Springs (Std.)			Check Valves* without Springs							
NPS	DN	C <sub>v</sub>	F <sub>L</sub>	x <sub>T</sub>	K <sub>i</sub>	d	ΔP <sub>FL</sub>	SP <sub>FL</sub>	C	ΔP <sub>FL</sub>	SP <sub>FL</sub>	C					
<b>Class 1500 (PN 260)</b> All Stop valves, all Stop-Check valves, all Piston Check valves																	
0.50	15	7.0	0.66	0.27	0.16	0.464	11.8	4.0	0.28	886	100	210	1.0	0.069	443	50.2	105
0.75	20	12				0.612	15.5			1520	172	207			760	86.0	103
1.00	25	12				0.815	20.7			1520	172	117			760	86.0	58
1.25	32	42				1.160	29.5			5320	602	201			2660	301	101
1.50	40	40				1.338	34.0			5060	574	144			2530	287	72
2.00	50	68				1.687	42.8			8610	975	154			4300	488	77
2.50	65	110				2.125	54.0			13,900	1580	157			6960	789	79
3.00	80	100				2.624	66.6			12,700	1430	94			6330	717	47
4.00	100	85				3.438	87.3			10,800	1220	46			5380	609	23

**Class 2500 (PN 420)** All Stop valves, all Stop-Check valves, all Piston Check valves

0.50	15	7.0	0.63	0.24	0.15	0.464	11.8	4.0	0.28	886	100	210	1.0	0.069	443	50.2	105
0.75	20	12				0.612	15.5			760	86.0	103			380	43.0	52
1.00	25	11				0.599	15.2			1390	158	198			696	78.9	99
1.25	32	30				0.896	22.8			3800	430	241			1900	215	121
1.50	40	28				1.100	28.0			3540	401	149			1770	201	75
2.00	50	70				1.503	38.2			8860	1000	200			4430	502	100
2.50	65	100				1.771	45.0			12,700	1430	206			6330	717	103
3.00	80	100				2.300	58.4			12,700	1430	122			6330	717	61
4.00	100	90				3.152	80.1			11,400	1290	58			5700	645	29

NOTES: See Table 9 for ΔP<sub>co</sub>. See notes following section 2.4.1 for discussion of C factor.

\* Stop-check valves are only furnished without springs.

**Table 8 – Forged Steel Inclined  
Bonnet Valve Flow Coefficients**

Black numerals are in U.S. customary units or dimensionless  
Colored numerals are in metric units

Size		Stop and Check Valves					Check Valves* with Springs (Std.)			Check Valves* without Springs							
NPS	DN	C <sub>v</sub>	F <sub>L</sub>	x <sub>T</sub>	K <sub>i</sub>	d	ΔP <sub>FL</sub>	SP <sub>FL</sub>	C	ΔP <sub>FL</sub>	SP <sub>FL</sub>	C					
<b>Class 600 (PN 110)</b> Figure No. 848/848Y Stop valve, 868/868Y Stop-Check valve, 838/838Y Piston Check valve																	
0.25	8	1.4	0.72	0.30	0.20	0.364	9.2	5.0	0.34	198	22.4	76	0.6	0.041	68.6	7.77	26
0.38	10	3.3				0.493	12.5			467	52.9	98			162	18.3	34
0.50	15	3.3				0.546	13.9			467	52.9	80			162	18.3	28
0.75	20	5.7				0.742	18.8			722	81.8	67			250	28.3	23
1.00	25	13.5				0.957	24.3			1910	216	106			662	75.0	37
1.25	32	23.5				1.278	32.5			3330	377	104			1150	131	36
1.50	40	37.5				1.500	38.1			5290	600	120			1830	208	42
2.00	50	48.5				1.939	49.3			6860	778	93			2380	269	32

NOTES: See Table 9 for ΔP<sub>co</sub>. See note following section 2.4.1 for discussion of C factor.

**Table 9 – Crack-Open  $\Delta P$  for Edward Forged Steel Check Valves,  $\Delta P_{CO}$  – PSI (BAR)**

Black numerals are in U.S. customary units or dimensionless  
Colored numerals are in metric units

Valve Type	Installation Orientation		Valves with Springs (Std.)		Valves without Springs	
Inclined, Bolted Bonnet, Piston Lift	Horizontal	Bonnet up	0.7 – 0.9	0.05 – 0.06	0.1 – 0.5	0.007 – 0.03
		Bonnet sideways*	0.3 – 0.8	0.02 – 0.06	—	—
		Bonnet down*	0.05 – 0.7	0.003 – 0.05	—	—
	Vertical	Bonnet up	0.7 – 1.0	0.05 – 0.07	0.1 – 0.3	0.007 – 0.02
		Bonnet down*	0.05 – 0.7	0.003 – 0.05	—	—
Inclined, Univalve®, Piston Lift	Horizontal	Bonnet up	1.0 – 1.5	0.07 – 0.10	0.4 – 0.8	0.03 – 0.06
		Bonnet sideways*	0.5 – 1.2	0.03 – 0.08	—	—
		Bonnet down*	0.05 – 1.1	0.003 – 0.08	—	—
	Vertical	Bonnet up	1.0 – 1.5	0.07 – 0.10	0.4 – 0.8	0.03 – 0.06
		Bonnet down*	0.05 – 1.1	0.003 – 0.08	—	—

\* Not recommended because of possible accumulation of debris in valve neck.

**Figure 20 – Ratio of Specific heats (k) for some gasses**

<b>k = 1.3</b>	Ammonia	Carbon Dioxide	Dry Steam	Methane	Natural Gas
<b>k = 1.4</b>	Air	Carbon Monoxide	Hydrogen	Nitrogen	Oxygen

**Figure 21A – Saturated Water - Temperature, Pressure & Density (U.S. Units)**

<b>Water Temp. °F</b>	32	70	100	200	300	400	500	550	600	650	700	705
<b>Vapor Pressure, <math>p_v</math></b>	0.09	0.36	0.95	11.5	67	247	681	1045	1543	2208	3094	3206
<b>Water Density, <math>\rho</math></b>	62.4	62.3	62.0	60.1	57.3	53.7	49.0	46.0	42.3	37.4	27.3	19.7

*P = Pressure in psia,  $\rho$  = Density in lb./ft<sup>3</sup>*

**Figure 21B – Saturated Water - Temperature, Pressure & Density (Metric)**

<b>Water Temp. °C</b>	0	25	50	100	150	200	250	300	350	370	374
<b>Vapor Pressure, <math>p_v</math></b>	.006	.032	.123	1.01	4.76	15.6	39.8	85.9	165.4	211	221
<b>Water Density, <math>\rho</math></b>	1000	997	988	958	917	865	799	712	574	452	315

*P = Pressure in Bar Absolute,  $\rho$  = Density in Kg/m<sup>3</sup>*



Figure 22 – Density of Steam

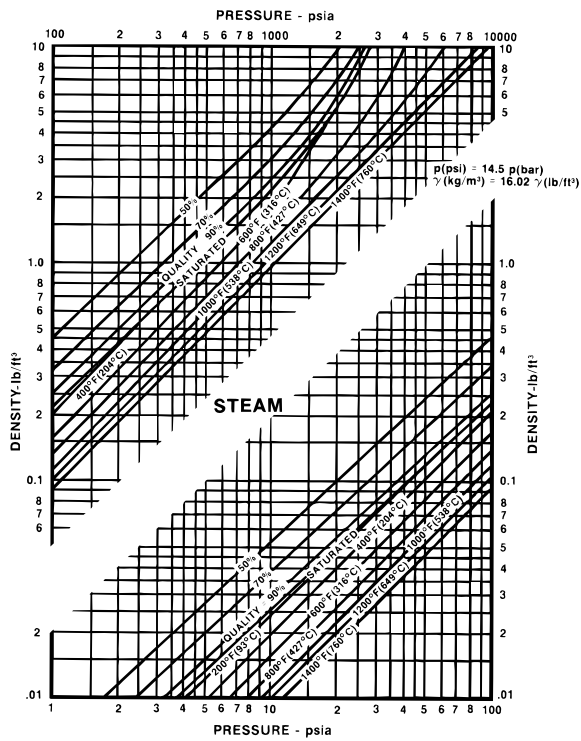

Figure 23 – Density of Air

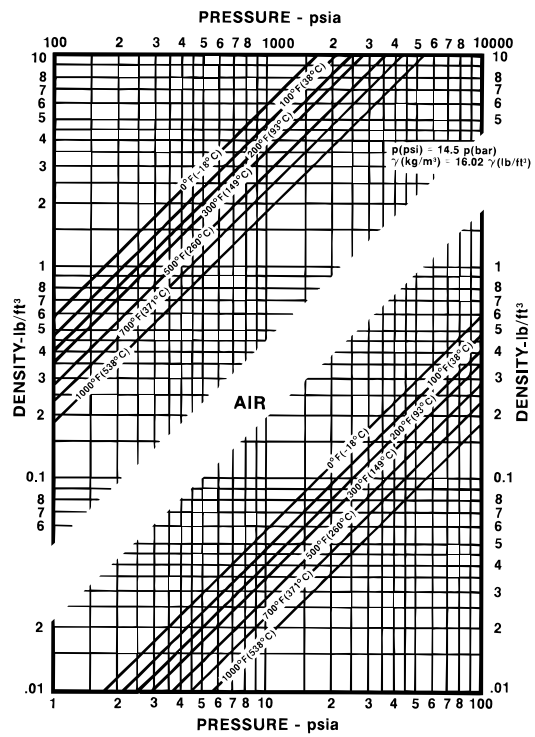
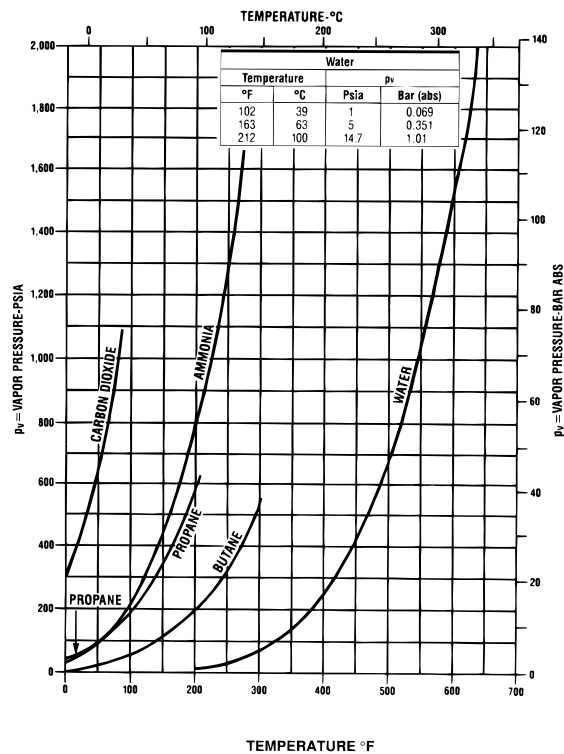

Figure 24 – Vapor Pressure of Liquid



# Conversion of Measurement Units

## Length

1 in. = 25.4 mm	1 mile = 5280 ft
1 in. = 2.54 cm	1 mile = 1.609 km
1 in. = 0.0254 m	1 km = 3281 ft
1 ft = 0.3048 m	1 m = 39.37 in.

## Area

1 in. <sup>2</sup> = 645.2 mm <sup>2</sup>	1 m <sup>2</sup> = 10.76 ft <sup>2</sup>
1 in. <sup>2</sup> = 6.452 cm <sup>2</sup>	1 m <sup>2</sup> = 1550 in. <sup>2</sup>
1 ft <sup>2</sup> = 144 in. <sup>2</sup>	

## Volume

1 in. <sup>3</sup> = 16.39 cm <sup>3</sup>	1 m <sup>3</sup> = 35.31 ft <sup>3</sup>
1 ft <sup>3</sup> = 1728 in. <sup>3</sup>	1 m <sup>3</sup> = 264.2 U.S. gal.
1 U.S. gal. = 231 in. <sup>3</sup>	1 m <sup>3</sup> = 220 Imp. gal.
1 U.S. gal. = 0.1337 ft <sup>3</sup>	1 m <sup>3</sup> = 1000 liters
1 U.S. gal. = 0.8327 Imp. gal.	1 liter = 61.02 in. <sup>3</sup>
1 U.S. gal. = 3.7854 liters	1 liter = 1000 cm <sup>3</sup>
1 ft <sup>3</sup> = 28.32 liters	1 ml = 1 cm <sup>3</sup>

## Density

1 lb/ft <sup>3</sup> = 16.02 kg/m <sup>3</sup>
1 lb/ft <sup>3</sup> = 0.01602 g/cm <sup>3</sup>
1 lb/in <sup>3</sup> = 1728 lb/ft <sup>3</sup>
density = specific gravity x reference density
density = 1/specific volume

## Specific Volume

specific volume = 1/density

## Temperature

T(°C) = T(°F - 32) / 1.8
T(°F) = 1.8 T(°C) + 32
T(°R) = T(°F) + 460
T(°K) = T(°C) + 273
T(°R) = 1.8 T(°K)

where:

°C = degrees Celsius
°F = degrees Fahrenheit
°K = degrees Kelvin (absolute temperature)
°R = degrees Rankine (absolute temperature)

## Specific Gravity – Liquids

$$G_l = \frac{\text{density of liquid}}{\text{density of water at reference condition}}$$

Commonly used relations are:

$$G_l = \frac{\text{density of liquid}}{\text{density of water at 60°F and atmospheric pressure}}$$

$$G_l = \frac{\rho \text{ (lb/ft}^3\text{)}}{62.38 \text{ (lb/ft}^3\text{)}}$$

$$G_l = \frac{\text{density of liquid}}{\text{density of water at 4°C and atmospheric pressure}}$$

$$G_l = \frac{\rho \text{ (kg/m}^3\text{)}}{1000 \text{ (kg/m}^3\text{)}}$$

282

For practical purposes, these specific gravities may be used interchangeably, as the reference densities are nearly equivalent.

Specific gravities are sometimes given with two temperatures indicated, e.g.,

$$G_l \frac{60^\circ\text{F}}{60^\circ\text{F}}, G_l \frac{15.5^\circ\text{C}}{4^\circ\text{C}}, G_l \frac{60^\circ\text{F}}{60^\circ\text{F}}$$

The upper temperature is that of the liquid whose specific gravity is given, and the lower value indicates the water temperature of the reference density. If no temperatures are shown, assume that the commonly used relations apply.

For petroleum liquids having an “API degrees” specification:

$$G_l \frac{60^\circ\text{F}}{60^\circ\text{F}} = \frac{141.5}{131.5 + \text{API degrees}}$$

## Pressure

1 Mpa = 145 psi	1 psi = 6895 Pa
1 pond = 1 gf	1 psi = 6895 N/m <sup>2</sup>
1 std atm = 14.696 psi	1 Pa = 1 N/m <sup>2</sup>
1 std atm = 1.0133 bar	1 bar = 14.50 psi
1 std atm = 1.0133 x 10 <sup>5</sup> N/m <sup>2</sup>	1 bar = 100,000 N/m <sup>2</sup>
1 kgf/cm <sup>2</sup> = 14.22 psi	
1 std atm =	

760 torr absolute pressure =  
gage pressure + atmospheric pressure

## Specific Gravity – Gases

$$G_g = \frac{\text{density of gas (at pressure and temperature of interest)}}{\text{density of air (at same pressure and temperature)}}$$

Because the relation between density, pressure and temperature does not always behave in an ideal way (i.e., ideally, density is proportional to pressure divided by temperature, in absolute units), use of the above relation requires that the pressure and temperature of interest be specified. This means that the specific gravity of a gas as defined may vary with pressure and temperature (due to “compressibility” effects).

Frequently, specific gravity is defined using:

$$G_g = \frac{\text{molecular weight of gas}}{\text{molecular weight of air}} = \frac{M_w}{28.96}$$

If this relation is used to calculate density, one must be careful to consider “compressibility” effects.

When the pressure and temperature of interest are at or near “standard” conditions (14.73 psia, 60°F) or “normal” conditions (1.0135 bar abs, 0°C), specific gravities calculated from either of the above relations are essentially equal.

## Pressure Head

1 foot of water at 60°F = 0.4332 psi

$$p \text{ (psi)} = \frac{\rho \text{ (lb/ft}^3\text{)} \times h \text{ (feet of liquid)}}{144}$$

$$p \text{ (N/m}^2\text{)} = \frac{\rho \text{ (kg/m}^3\text{)} \times h \text{ (meters of liquid)}}{0.1020}$$

$$p \text{ (bar)} = \frac{\rho \text{ (kg/m}^3\text{)} \times h \text{ (meters of liquid)}}{10200}$$

1 meter of water at 20°C = 9.790 kN/m <sup>2</sup>
1 meter of water at 20°C = 97.90 mbar
1 meter of water at 20°C = 1.420 psi

## Flow Rate

• mass units  
1 lb/hr = 0.4536 kg/hr  
1 metric tonne/hr = 2205 lb/hr

• liquid volume units  
1 U.S. gpm = 34.28 BOPD  
BOPD = barrels oil per day  
1 U.S. gpm = 0.8327 Imp. gpm  
1 U.S. gpm = 0.2273 m<sup>3</sup>/hr  
1 U.S. gpm = 3.785 liters/min  
1 m<sup>3</sup>/hr = 16.68 liters/min  
1 ft<sup>3</sup>/s = 448.8 U.S. gpm

• mixed units  
w(lb/hr) = 8.021 q(U.S. gpm) x ρ(lb/ft<sup>3</sup>)  
w(lb/hr) = 500 q(U.S. gpm of water at 70°F or less)

In the following:

STP (standard conditions) refers to 60°F, 14.73 psia  
NTP (normal conditions) refers to 0°C, 1.0135 bar abs

$$G_g = \frac{\text{molecular weight of gas}}{\text{molecular weight of air}} = \frac{M_w}{28.96}$$

w(lb/hr) = 60 q(scfm of gas) x ρ(lb/ft<sup>3</sup>) at STP  
w(lb/hr) = q(scfm of gas) x ρ(lb/ft<sup>3</sup>) at STP  
w(lb/hr) = 4.588 q(scfm of gas) x G<sub>g</sub>  
w(lb/hr) = 0.07646 q(scfm of gas) x G<sub>g</sub>  
w(lb/hr) = 3186 q(MMscfd of gas) x G<sub>g</sub>  
MMscfd = millions of standard cubic feet per day  
w(kg/hr) = q(normal m<sup>3</sup>/hr of gas) x ρ(kg/m<sup>3</sup> at NTP)  
w(kg/hr) = 1.294 q(normal m<sup>3</sup>/hr of gas) x G<sub>g</sub>

### 3. Flowserve Valve Design Standards and Features

Engineering and research efforts—both analytical and experimental—have contributed to innovative leadership by Flowserve Valves through the introduction or practical development of some major industrial valving features:

- Integral hardfaced seats in globe and angle valves to permit compact valve designs and to resist erosion and wear.
- Impactor handwheels and handles to permit tight shutoff of manually operated globe, angle valves and gate valves.
- Body-guided globe and angle valve discs to minimize wear and ensure alignment with seats for tight sealing.
- Inclined-bonnet globe valves with streamlined flow passages to minimize pressure drop due to flow.
- Equalizers for large piston (lift) check and stop-check valves to ensure full lift at moderate flow rates and to prevent damage due to instability.
- Compact pressure-seal bonnet joints to eliminate massive bolted flanges on large high-pressure valves:
  - First with wedge-shaped metal gaskets with soft coatings, optimized over more than four decades to provide tight sealing in most services.
  - Now, for the severest services, with composite gaskets using flexible graphite and special anti-extrusion rings to ensure tight sealing, even with severe temperature transients—overcomes need for field re-tightening and eases disassembly for maintenance.
- Optimized stem-packing chambers and packing-material combinations to ensure tight stem sealing:
  - First with asbestos-based materials and then with asbestos-free materials.
- Hermetically sealed globe valves with seal-welded diaphragm or bellows stem seals to prevent stem leakage in critical applications, including nuclear.
- Gate valves with flexible double-wedge and double-disc construction to ensure tight sealing at both low and high pressures and to prevent sticking difficulties when opening.

- Qualified stored-energy actuators for quick-closing valves in safety-related nuclear-plant applications—and qualified valve-actuator combinations that are used in main-steam isolation service throughout the world.

Flowserve valve expertise, acquired over more than 110 years, is shared with national and international codes-and-standards committees and other technical societies and groups whose activities influence industrial valves. This cooperation has included participation in the development of every issue of ASME/ANSI B16.34 as well as most issues of ASME/ANSI B16.5 (Pipe Flanges and Flanged Fittings), which applied to steel valves before ASME/ANSI B16.34 was first issued in 1973. Flowserve representatives have also been active in preparation of ISO (International Standards Organization) standards. In addition, Flowserve representatives have participated where appropriate with trade organizations such as EPRI, INPO and various nuclear power-plant owners' groups in addressing valve issues.

#### 3.1 Codes and Standards

Flowserve Edward valves are designed, rated, manufactured and tested in accordance with the following standards where applicable:

- ASME B16.34-2004 – Valves: flanged, threaded and welding end.
- ASME/ANSI B16.10-2000– Face-to-face and end-to-end dimensions of valves.
- ASME B16.11 – Forged Fittings, Socket-welding and Threaded.
- ASME Boiler and Pressure-Vessel Code – Applicable sections including Nuclear Section III.
- ASME and ASTM Material Specifications – Applicable sections.
- MSS Standard Practices – Where appropriate: Edward sealability acceptance criteria are equal to or better than those in MSS SP-61.

Users should note that ASME/ANSI B16.34-2004 has a much broader scope than the previous editions. While this standard previously covered only flanged-end and butt welding-end valves, the 1988 edition covered socket welding-end and threaded-end valves as well. With this revision, the standard now addresses practically all types, materials and

end configurations of valves commonly used in pressure-piping systems. Edward valves in this catalog with a listed class number (e.g., Class 1500) comply with ASME B16.34.

In addition to the standards listed, special requirements such as those of API and NACE are considered on application.

#### 3.2 Pressure Ratings

Flowserve Edward valve-pressure ratings are tabulated in pressure-versus-temperature format. The temperatures range from -20°F (-29°C) to the maximum temperature permitted for each specific design and pressure-boundary material. Typically, pressure ratings decrease with increasing temperature, approximately in proportion to decreases in material strength.

Valves in this catalog with a listed class number are rated in accordance with ASME B16.34-2004. This standard establishes allowable working pressure ratings for each class number and material. These ratings also vary with class definitions as described below.

**Standard Class** (Ref: Paragraph 2.1.2 of ASME B16.34-2004) – These lowest ratings apply to flanged-end valves as well as any threaded-end or welding-end valves that do not meet the requirements for other classes. Typically, ratings for these valves are consistent with ratings listed for flanges and flanged fittings of similar materials in ASME/ANSI B16.5-2003.

**Special Class** (Ref: Paragraph 2.1.3 of ASME B16.34-2004) – These ratings apply to threaded-end or welding-end valves which meet all requirements for a Standard Class rating and in addition meet special nondestructive examination (NDE) requirements. Valve bodies and bonnets are examined by volumetric and surface examination methods and upgraded as required. Pressure ratings for Special Class valves are higher than those for Standard Class valves (particularly at elevated temperatures) because of the improved assurance of soundness of pressure boundaries and because they are not subject to the limitations of flanged and gasketed end joints.

### Series or CWP

A few valves in this catalog with “Series” or “CWP” designations are designed, rated, manufactured and tested to Flowserve Edward Valves proprietary standards. These valve designs, qualified by decades of successful field performance, will provide safe and reliable service in applications where an ASME/ANSI rating is not required by a piping code or other specifications.

These valve designs and ratings are generally, but not completely, in conformance with recognized national standards (e.g., some employ high-strength materials not listed in standards). These valves have a history of excellent performance and safety, and they may be applied with confidence in applications where ASME/ANSI ratings are not required.

### Notes:

1. While Edward cast-steel valves described in this catalog have even listed ratings (e.g., 1500), many designs provide more wall thickness than required in critical areas. Accordingly, welding-end valves can often be offered with intermediate ratings (ref: Paragraph 6.1.4 of ASME B16.34-2004) moderately higher than the nominal class ratings. With appropriate revisions to testing procedures, this can allow somewhat higher pressure ratings than those listed in the tabulations. Consult Edward Valves and provide information on specific required design pressure and temperature conditions.
2. Pressure ratings for carbon steel (A105 and A216 WCB) valves are tabulated for temperatures through 1000°F (538°C), which is consistent with ASME B16.34-2004. As noted in that standard, these materials are permissible but not recommended for prolonged usage at above about 800°F (427°C). This precaution is related to the possibility that carbides in carbon steel may be converted to graphite.

3. Other codes or standards applicable to piping systems may be more restrictive than ASME B16.34-2004 in limiting allowable pressures for valves. For example, ASME B31.1-1995 (Power Piping) does not permit use of carbon steel (A105 and A216 WCB) at design temperatures above 800°F (427°C). Users must consider codes or regulations applicable to their systems in selecting Edward Valves.

4. The maximum tabulated temperatures at which pressure ratings are given for Edward valves are in some cases less than the maximum temperatures given in ASME B16.34-2004 for valves of the same material. The maximum tabulated temperatures in this catalog may reflect limitations of materials used for other valve parts (e.g., stems). Use of Edward valves at temperatures above the maximum tabulated values may result in degradation and is not recommended.

### 3.3 Pressure-Seal Construction

The time-proven Edward pressure-seal bonnet seals more effectively as pressure increases, because the pressure forces the sealing elements into closer contact. Metal pressure-seal gaskets with soft plating employ optimum contact angles and materials for each applicable valve type, size and pressure-class rating. The gaskets yield initially under bolting load and then under pressure, to provide excellent sealing contact.

New designs for highest pressure/temperature services employ improved composite pressure-seal gaskets with flexible graphite rings. Flowserve leadership in proof-testing of Edward Valves flexible graphite stem packings clearly showed the superior sealing characteristics of this material, and continued research led to the development of a test-proven bonnet closure that provides highest sealing integrity. The composite pressure-seal provides excellent sealing at low and high pressures, even under severe pressure/temperature transients. It provides easier disassembly for maintenance, seals over minor scratches and does not depend on retightening under pressure after reassembly.

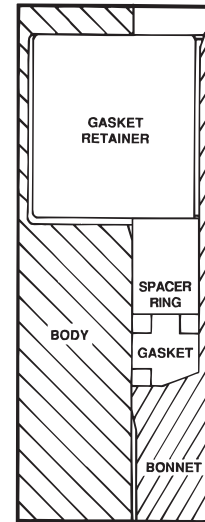

Composite Pressure-Seal Construction

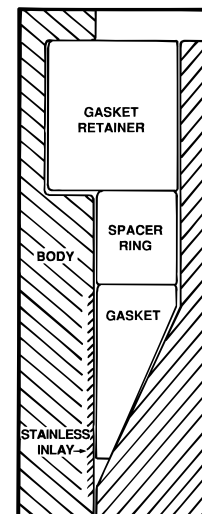

Typical Pressure-Seal Construction

### 3.4 Hardfacing

Integrity of seating surfaces on bodies, wedges and discs in gate, globe and check valves is essential for tight shutoff. Valve body seats must be hardfaced, and wedges and discs must either be hardfaced or made from an equivalent base material.

The standard seating material for most Edward valves is cobalt-based Stellite 21<sup>®</sup>, which has excellent mechanical properties and an exceptional performance history. As compared to Stellite 6<sup>®</sup>, which was used in many early Edward valves and is still used in many competitive valves, Stellite 21<sup>®</sup> is more ductile and impact resistant. These properties provide superior resistance to cracking of valve seating surfaces in service.

Stellite 21 is used either as a complete part made from a casting (as in Univalve discs and small Equiwedge gate valve wedges) or as a welded hardsurfacing deposit. Depending on valve size and type, hardsurfacing material is applied by a process that ensures highest integrity (PTA, MIG, etc.).

While the as-deposited (or as-cast) hardness of Stellite 21 is somewhat lower than that of Stellite 6, Stellite 21 has a work-hardening coefficient that is five times that of Stellite 6. This provides essentially equivalent hardness after machining, grinding, and exposure to initial seating stresses. In addition, low friction coefficients attainable with Stellite 21 provide valuable margins in assuring valve operation with reasonable effort or actuator sizing.

The properties of Stellite 21 also provide an advantage to the user long after a valve leaves the Edward plant. If a large valve seat is severely damaged in a localized area, as may occur due to closing on foreign objects, the seat may be repaired locally and refinished, in such cases, where a valve cannot be adequately preheated before welding, a Stellite 6 seat may crack during the repair process – requiring either removal of the valve from the line or in situ removal replacement of the complete seat.

Some Edward valves have used solid discs made of hardened ASTM A-565 Grade 616 or 615 stainless steel. This corrosion-resistant alloy has been proven in seating and erosion tests and in service. This material can be furnished in certain valves for nuclear-plant services where reduced cobalt is desirable. Similar iron-base trim materials are used in production of certain standard valves. Extensive research on other cobalt-free valve

trim materials has also identified other alloys which provide good performance under many service conditions. Consult Flowserve about any special trim requirements.

### 3.5 Valve-Stem Packing

Stem sealing is an extremely important valve performance feature, since seal leakage can represent energy loss, a loss of product and a potential environmental or safety hazard. Consequently, Edward stop and stop-check valves employ stem packings that have been qualified by extensive testing.

The search for improved sealing performance was a primary reason for seeking out new stem-packing materials to replace asbestos-based packings. The demand of many valve users to discontinue use of asbestos due to health risks was an important secondary reason. Since there are no simple laboratory tests that will predict sealing performance based on measurable properties of packing materials, hundreds of tests have been necessary with various packings in valves or valve mockups.

Some packings required frequent adjustments due to wear, extrusion or breakdown, and some could not be made to seal at all after relatively brief testing. All standard Edward stop and stop-check valves now employ flexible graphite packing which provides excellent stem sealing. However, the key to its success involves retaining the graphitic material with special, braided end rings to prevent extrusion. Various end rings are used, depending on the valve pressure class and expected service-temperature range. All Edward valves assembled since January 1986 have been asbestos-free.

See V-REP 86-2 for more information.

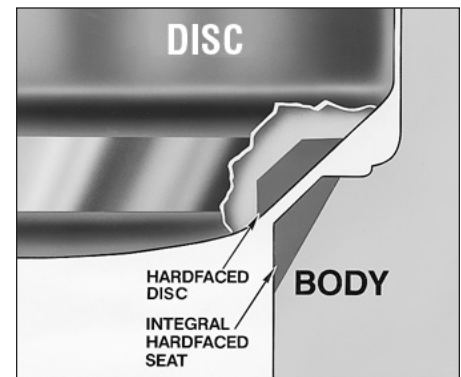



## **Maintenance**

### **FLOWSERVE EDWARD VALVES ON-SITE FIELD SERVICE REPAIR CAPABILITIES**

Flowserve is totally committed to customer service satisfaction. Our entire manufacturing operation guarantees we will stand behind our field service repair work to maximize customer support.

#### **OUR FACILITY OFFERS**

- Mobile machine shop trailer for on-site repairs
- After-hours, plant-based service team for around-the-clock coverage
- Expertly trained field service personnel capable of handling any size of field service job
- Special equipment for seat refinishing, body boring, welding and stress relieving
- In-house valve repair and return remanufacturing to original specifications with new valve warranty
- Experience in turnkey jobs to help the customer with one-stop shopping
- 180 000-sq.-ft. manufacturing facility with state-of-the-art machining and engineering capability and ISO 9001 certification
- Flowserve Raleigh is ISO 9001 certified and approved by Hartford Steam Boiler Global Standards (HSBGS) Quality Assurance

**Phone Toll-Free  
24 Hours a Day  
365 Days a Year  
(Day) 1-800-225-6989  
(Night) 1-800-543-3927**

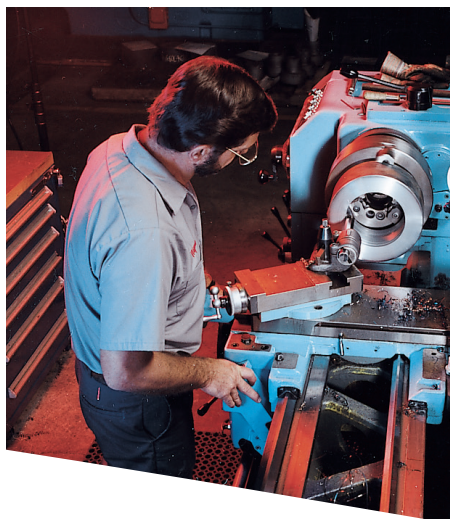

## STAYING ON-LINE WITH FLOWSERVE

We design and manufacture our valves for 40 years' life in the field. That means not just building a reliable product, but one that is easy to maintain and service. It also means providing a team of experienced, dedicated professionals to keep your Flowserve valves operating at peak performance.

### Highly Experienced Technicians

Flowserve brings unmatched experience to the field. Our service technicians have an average 20 years in the industry, and 15 years with Flowserve. Each has special skills, such as welding and machining, that we can target for the needs of the individual job.

### Comprehensive Record-keeping

Our files include original specifications for every Flowserve valve sold since 1908. All valves are coded for easy identification. On new and replacement orders, Flowserve stands ready to provide the complete lot-traceability required for nuclear and other critical services.

### In-line Service

We are dedicated to on-site service whenever possible. To this end, we not only provide highly experienced, expert personnel—but we also support those technicians with field equipment, including portable boring, lapping, welding and weld-cutting machines. Major parts, such as discs or bonnets, can be air-shipped back to the factory for service and repaired while service personnel perform other tasks.

### Parts Replacement

Our comprehensive record-keeping system also facilitates replacement of parts. Our computer database can quickly show us if we have the part in stock or on order, or how we can best coordinate raw materials and factory resources for the quickest possible turnaround time.

### New 90-day Warranty

On all valves repaired to Flowserve's standards, we will issue a new 90-day warranty.

### Factory Repair & Upgrading

Our After-Hours Coverage Team (AHCT) specialists are on-call around the clock, seven days a week, to deliver on our commitment to provide immediate response to our customers' requirements. Whether your requirements are for a planned outage, preventive maintenance or an emergency demand, Flowserve will remanufacture or upgrade valves to the original or most current specification. Our in-house engineering and quality assurance support is committed to meet the required turnaround time.

### Planned & Emergency Outages

Our service managers will coordinate scheduled maintenance, and also get technical assistance to your facility quickly for emergency needs.



**United States**  
Flowserve Corporation  
Flow Control  
1900 South Saunders Street  
Raleigh, NC 27603  
Telephone: +1 919 832 0525  
Telefax: +1 919 831 3369

FCD EVENCT0004-03 Printed in USA.

***To find your local Flowserve representative:***

For more information about Flowserve Corporation, visit  
[www.flowserve.com](http://www.flowserve.com) or call USA 1 800 225 6989

Flowserve Corporation has established industry leadership in the design and manufacture of its products. When properly selected, this Flowserve product is designed to perform its intended function safely during its useful life. However, the purchaser or user of Flowserve products should be aware that Flowserve products might be used in numerous applications under a wide variety of industrial service conditions. Although Flowserve can (and often does) provide general guidelines, it cannot provide specific data and warnings for all possible applications. The purchaser/user must therefore assume the ultimate responsibility for the proper sizing and selection, installation, operation and maintenance of Flowserve products. The purchaser/user should read and understand the Installation Operation Maintenance (IOM) instructions included with the product, and train its employees and contractors in the safe use of Flowserve products in connection with the specific application.

While the information and specifications contained in this literature are believed to be accurate, they are supplied for informative purposes only and should not be considered certified or as a guarantee of satisfactory results by reliance thereon. Nothing contained herein is to be construed as a warranty or guarantee, express or implied, regarding any matter with respect to this product. Because Flowserve is continually improving and upgrading its product design, the specifications, dimensions and information contained herein are subject to change without notice. Should any question arise concerning these provisions, the purchaser/user should contact Flowserve Corporation at any one of its worldwide operations or offices.

© 2015 Flowserve Corporation, Irving, Texas, USA. Flowserve is a registered trademark of Flowserve Corporation.