

***Durco<sup>®</sup>  
Mark 3<sup>™</sup>  
In-Line  
ASME (ANSI)  
B73.2 Vertical  
In-Line Chemical  
Process Pumps***

## Pump Supplier To The World

*Flowserve is the driving force in the global industrial pump marketplace. No other pump company in the world has the depth or breadth of expertise in the successful application of pre-engineered, engineered, and special purpose pumps and systems.*

### Pumping Solutions

Flowserve is providing pumping solutions that permit customers to continuously improve productivity, profitability and pumping system reliability.

### Market-Focused Customer Support

Product and industry specialists develop effective proposals and solutions directed toward market and customer preferences. They offer technical advice and assistance throughout each stage of the product life cycle, beginning with the inquiry.



### Dynamic Technologies

Flowserve is without peer in the development and application of pump technology, including:

- Hydraulic engineering
- Mechanical design
- Materials science
- Intelligent pumping
- Manufacturing technology

### Broad Product Lines

Flowserve offers a wide range of complementary pump types, from pre-engineered process pumps, to highly engineered and special purpose pumps and systems. Pumps are built to recognized global standards and customer specifications.

Pump designs include:

- Single-stage process
- Between bearing single-stage
- Between bearing multistage
- Vertical
- Submersible motor
- Positive displacement
- Nuclear
- Specialty

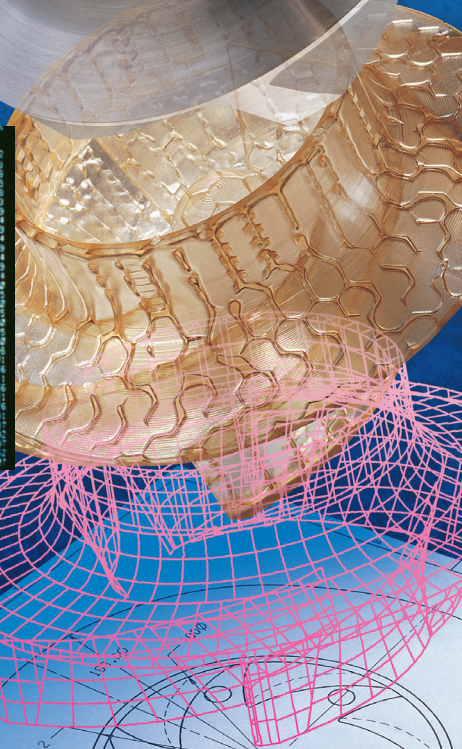
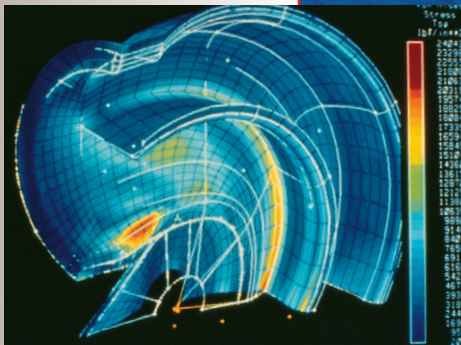
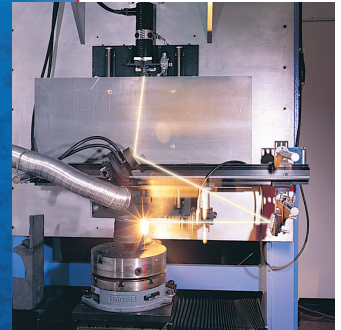
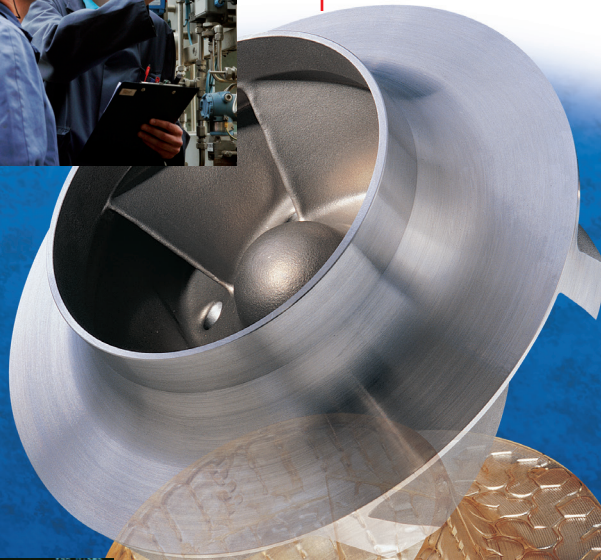

**Mark 3 In-Line  
ASME (ANSI)  
B73.2 Vertical  
In-Line Chemical  
Process Pumps**

**Without Equal**

Designed to exceed ASME (ANSI) B73.2 criteria, the Durco Mark 3 In-Line is more than a space-saving chemical process pump. It offers improved pump reliability and extended mean time between planned maintenance (MTBPM) through these exclusive features:

- Standard Mark 3A power frame with micrometer impeller adjustment
- Optional ANSI 3A™ power frame with three-year MTBPM guarantee

- The unique reverse vane impeller with consistent, repeatable performance
- SealSentry™ seal chambers including models with flow modifiers
- The unique C-Plus precision motor and pump shaft alignment system
- Broad parts interchangeability with standard Mark 3 horizontal pumps
- Complete menu of mechanical seal options, including advanced gas seal technology, to best meet application needs
- A wide array of options and accessories for extended MTBPM and improved safety

**Primary Industries Served**

- Chemical processing
- Hydrocarbon processing
- General industry

**Complementary Pump Designs**

Depending upon application requirements, Flowserve can also provide these pump designs:

- HW ISO 13709/API 610 compliant in-line
- MSP low flow, high head in-line with variable frequency drive
- Mark 3 ASME (ANSI) horizontal standard
- CPX ISO horizontal standard
- PVML ISO 13709/API 610 compliant, in-line with multi-channel diffuser

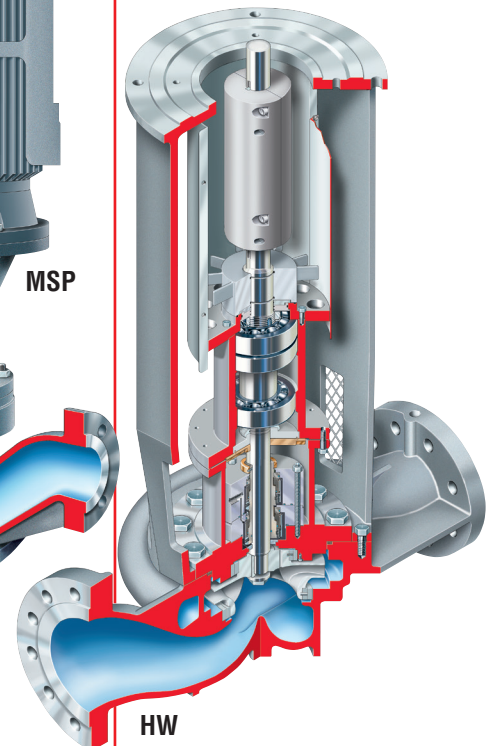
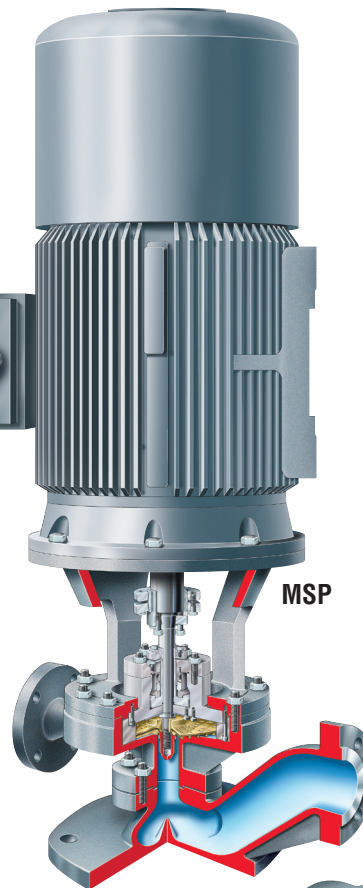
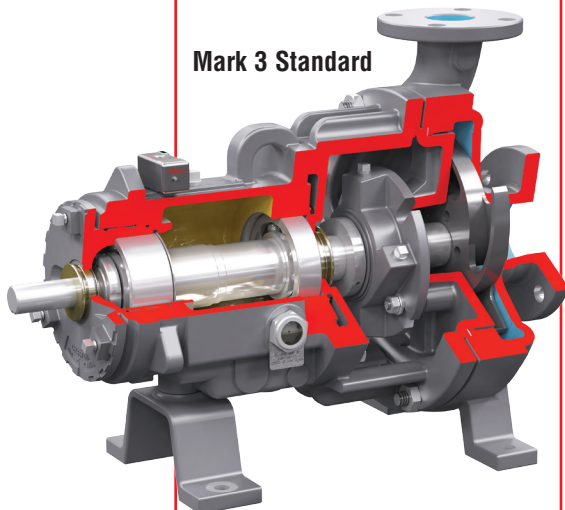
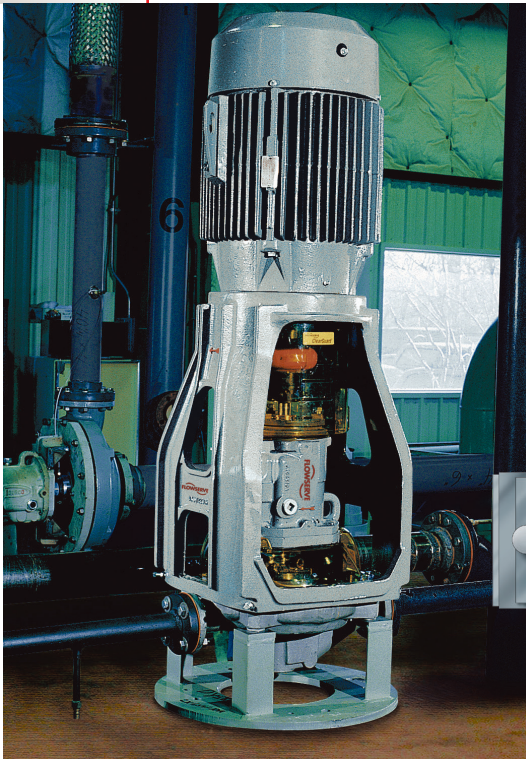

**Mark 3 In-Line  
ASME (ANSI)  
B73.2 Vertical  
In-Line Chemical  
Process Pumps**

The Durco Mark 3 In-Line ASME (ANSI) process pump delivers extended pump life, ease of maintenance and safety in addition to reliable, efficient performance. This space-saving pump has broad application in chemical and hydrocarbon processing as well as in general industry for services including:

- Chemical transfer
- Heat transfer
- Liquid gases
- Storage
- Water

- Washdown and cleaning
- Condensate return
- Light slurries

**Operating Parameters**

- Flows to 370 m<sup>3</sup>/h (1630 gpm)
- Heads to 230 m (755 ft)
- Pressures to 24 bar (350 psi)
- Temperatures to 370°C (700°F)
- Motor sizes to 110 kW (150 hp)

***C-Flange Adapter** is precision machined to provide fixed motor to pump angular shaft alignment within 0.001 mm/mm (0.001 in/in).*

***Adjustable Parallel Alignment** of motor to pump shaft to within 0.05 mm (0.002 in) reduces coupling loads to improve pump, seal, motor and coupling life.*

***Broad Choice of Coupling Designs** due to precisely adjustable parallel and fixed angular motor to pump shaft alignment. Conventional spacer coupling type is standard.*

***Open Motor Adapter** permits ready access to seals and seal flush connections for reduced maintenance time.*

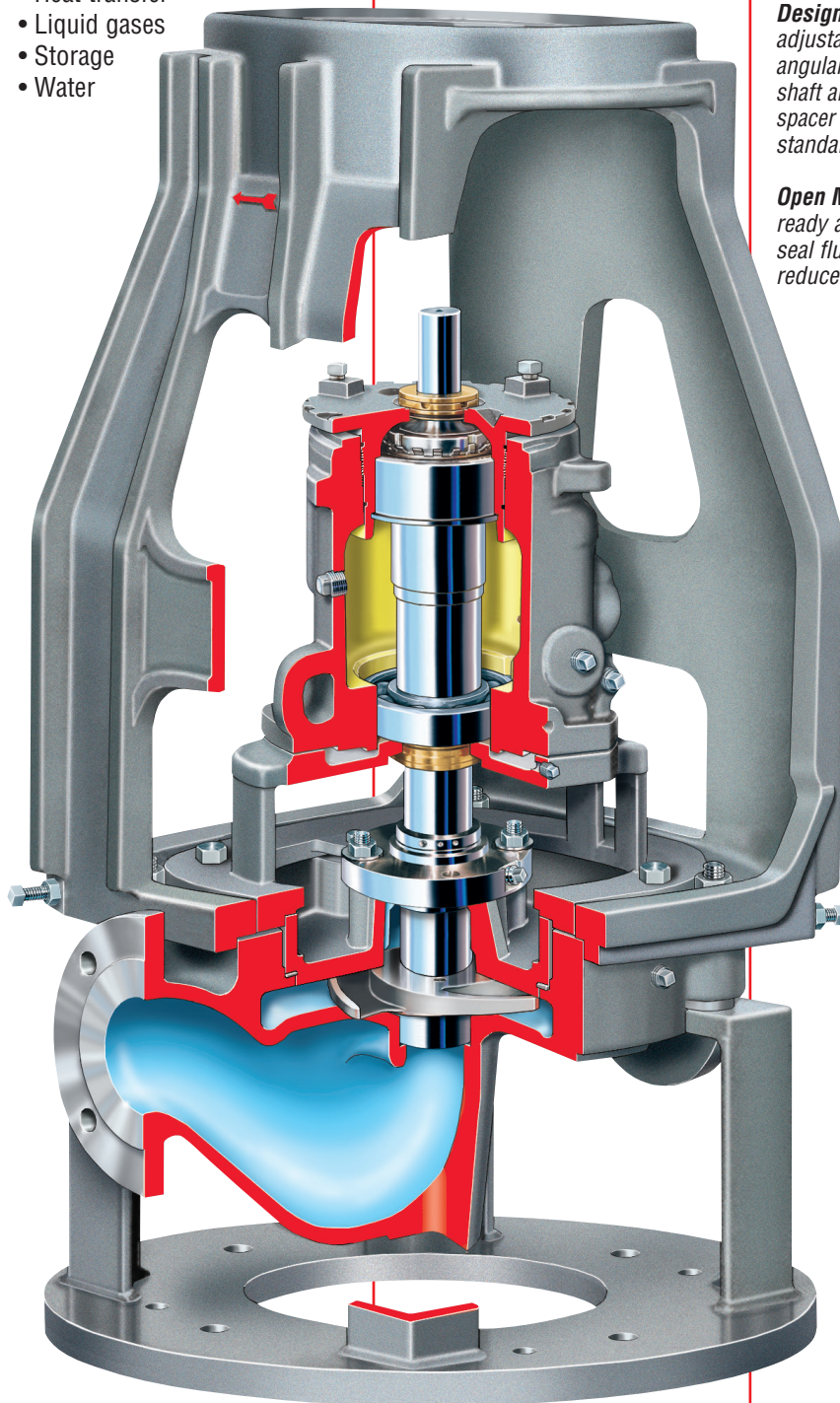

**Mark 3 Power Ends** are completely interchangeable with Mark 3 standard pumps and offer:

- Double-row angular-contact outboard and single-row deep-groove inboard bearings for excellent axial and radial load support
- Double-lip oil seals
- Micrometer shaft adjustment for precisely accurate impeller-to-seal chamber setting and reduced maintenance time

**Reduced Parts Inventory** due to interchangeability with horizontal Mark 3

- Standard power ends
- Standard adapters
- Standard shafts
- Standard seals
- Standard hardware and fasteners

**Superior Pipe Load Capacity** as loads are transferred through the casing, eliminating misalignment of the pump and motor.

**Streamlined Suction Nozzle** eliminates turbulence for low NPSH requirements.

**Flange Connections** are available in ASME Class 150 or Class 300 with flat or raised faces.

**Pump Bearings** carry impeller loads — not the motor. With the largest shaft and bearing components available in standard ASME (ANSI) pumps, the Mark 3 offers greater load-handling ratings and deflection comparisons (< 0.05 mm [0.002 in] deflection at seal faces) for extended MTBPM. Regreasable bearing lubrication is standard.

**Coupling Guards** are available in steel, aluminum or polycarbonate materials to ASME B15.1 requirements.

### Design Features



#### Micrometer Impeller Adjustment

- Impeller clearance setting to rear cover in 20 seconds
- No shims or wear rings
- In-shop or in-field adjustment

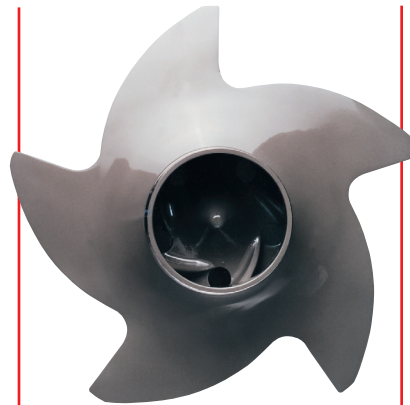

#### Reverse Vane Impeller

- Low, predictable seal chamber pressure and thrust loads for longer seal and bearings life
- Lowest overall NPSH required of any standard pump
- Rear cover plate wear surface instead of the more expensive casing
- In-shop or field impeller and mechanical seal setting
- Repeatable performance assurance

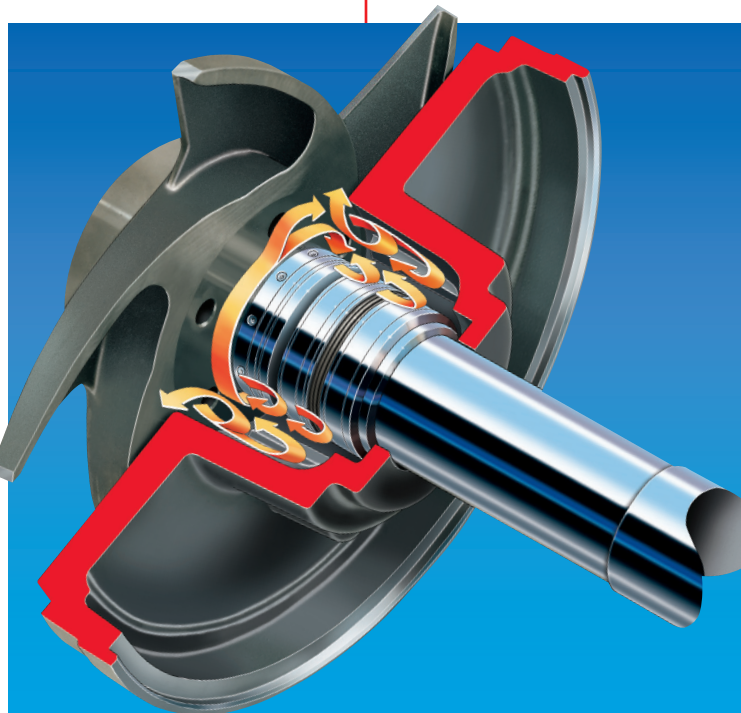

### Advanced Mark 3 Seal Sentry Design Technology

- Extend seal life
  - Self-flushing
  - Self-venting
  - Self-draining
- Reduce maintenance and repair costs
- Permit use of less expensive seals and flush plans
  - Flush plans 11, 32, 52, 53, etc. can be eliminated
- Increase MTBPM
- Provide a safer environment for personnel
- Available in multiple designs to precisely match application needs
  - Tapered bore
    - FML (large gland bolt circles)
    - FMS (small gland bolt circles)
    - FMI (integral gland)
  - Cylindrical bore
    - CBL (large gland bolt circles)
    - CBS (small gland bolt circles)

### Flow Modifiers Extend Mechanical Seal MTBPM

- Flow modifiers redirect flow from circumferential to axial
- Balanced flow with low pressure drop in the chamber helps keep solids in suspension, minimizing erosive characteristics of the process
- A mechanical seal creates a centrifuging action away from its parts and into the returning flow path of the process liquid
- Solids and slurry merge in the returning flow path and are flushed out of the seal chamber

## Technical Data and Options

### The Heart of the Pump: Shaft and Bearing Design

Flowserve offers the largest shaft and bearing components available in standard ASME (ANSI) pumps. A comparison of the Mark 3 Group 2 power end with that of a major competitor demonstrates the benefits of heavy-duty design.

#### Standard Mark 3 Power End

- Lubrication options
  - Regreasable bearings
  - Oil mist
  - Permanently lubricated bearings
- Bearing isolators
  - Inpro Seal's non-contact Vapor Block

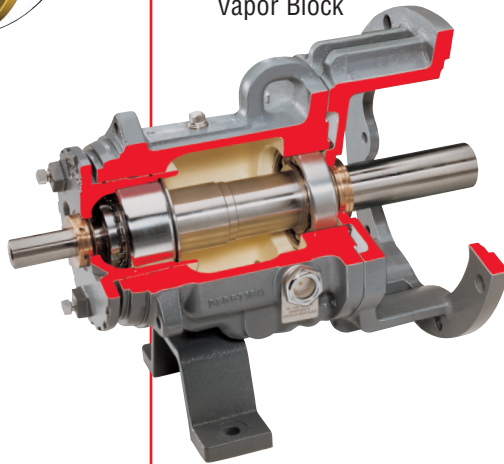
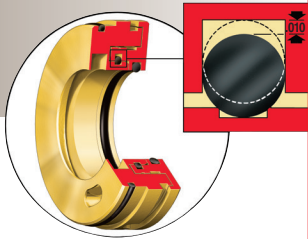

**Mark 3 In-Line Range Chart**

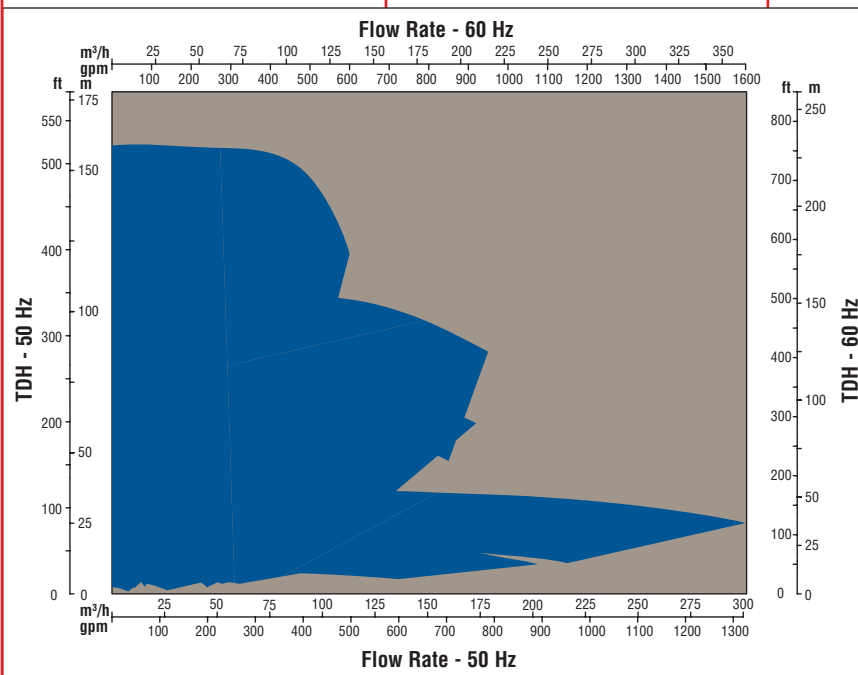

\* Note: Adherence to proper installation, operation and maintenance procedures is necessary for Lifetime warranty. Contact your Flowserve representative for detailed terms and conditions.

**Table 1  
Bearing Comparison**

Group 2	I.B. Bearing	Dynamic Load Rating	O.B. Bearing	Dynamic Load Rating
<b>Flowserve</b>	6310 (13 400 lb)	6078 kg (19 200 lb)	5310	8709 kg
<b>Major Competitor</b>	6309 (11 900 lb)	5398 kg (16 400 lb)	5309	7439 kg

Mark 3 bearings last up to 61% longer.

**Table 2  
Deflection Comparison**

Group 2	Overhang Length	Solid Shaft Diameter	Deflection Index	Shaft Dia. w/sleeve	Deflection Index
<b>Flowserve</b>	189 mm (7.687 in)	48 mm (1.875 in)	37	38 mm (1.5 in)	90
<b>Major Competitor</b>	213 mm (8.375 in)	45 mm (1.75 in)	63	38 mm (1.5 in)	116

Mark 3 shafts are 43–252% more stiff.

#### Optional ANSI 3A Power End

- Lifetime warranty\*
- Certified clean room assembly

#### Pump Stand

- Large footprint for stability
- Permits fixed mounting of pump unit
- Reduced installation costs

#### Additional Options

- Jacketed seal chamber
- DurcoShield™ splash and shaft guard
- ClearGuard™ non-metallic coupling guard



**Global Engineered Services and Support**

- Total Cost Reduction*
- Asset Management*
- Product Life Cycle*
- Performance Re-rates*
- Site Diagnostics*
- Repair Services*
- Energy Management*
- Spare Parts*
- Maintenance Contracts*
- Materials Upgrades*
- Turnkey Services*
- Field Repairs*
- Installation*
- Project Supervision*
- Commissioning*
- Equipment Upgrades*
- Condition Monitoring*
- Systems Analysis*
- Field Machining*

**Service Dedication**

Flowserve Engineered Services is focused on providing customers with uncompromising service and support, where and when needed. Dedicated to delivering the highest quality support, Engineered Services integrates its extensive pump and materials engineering knowledge with creative service solutions. Engineered Services fully understands the business challenges facing customers and is prepared to manage solutions to succeed as a team.

A worldwide network of service and repair centers staffed by highly skilled engineers and technicians is available around the clock, seven days a week to respond to customer queries, to evaluate and troubleshoot problems and to provide reliable solutions.



**Strength of Experience, Commitment to Excellence**

Flowserve has long served industries requiring superior equipment performance and service life.

- Oil and gas production
- Hydrocarbon processing
- Chemical processing
- Water resources
- Power generation
- Nuclear
- Mining and mineral processing
- Pulp and paper
- General industry

Engineered Services is dedicated to maximizing equipment performance and providing reliability-centered maintenance programs for pumps and related equipment, regardless of manufacturer. Using the FlowStar™ asset management software, Engineered Services tracks performance and supports improvement programs using a service life cycle cost business approach. The results are improved reliability and increased profitability.

**Business Partner**

Flowserve partners with customers to respond to the dynamic business conditions that affect them. Flowserve will work with customers to drive efficiency, maximize throughput and control process quality. Whether user needs involve on-site technical assistance or broader project planning with full turnkey responsibility, Flowserve Engineered Services will deliver professional, reliable results.

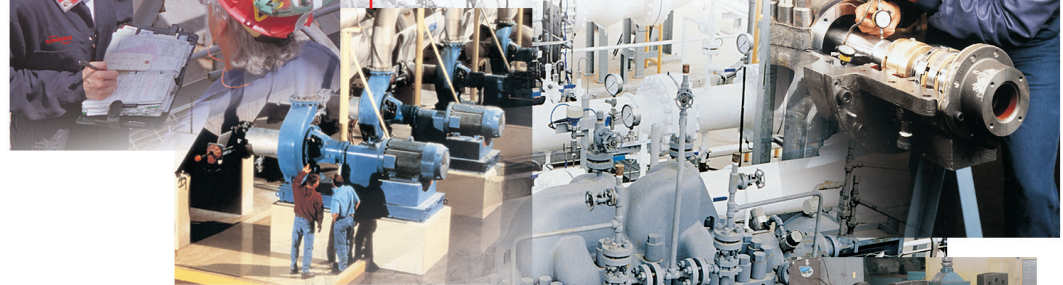

**Low Frequency Pressure Pulsation**

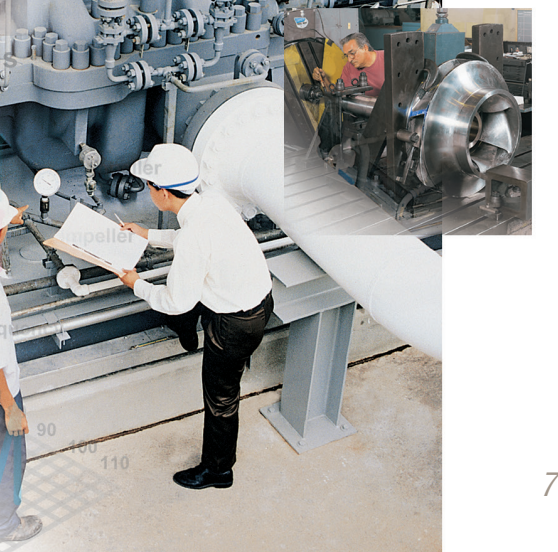
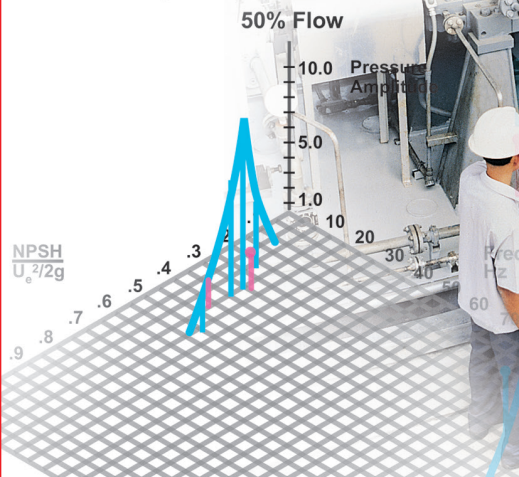

**Flowserve... Supporting Our Customers  
With The World's Leading  
Pump Brands**



**USA and Canada**

Flowserve Corporation  
5215 North O'Connor Blvd.  
Suite 2300  
Irving, Texas 75039-5421 USA  
Telephone: +1 937 890 5839

**Europe, Middle East, Africa**

Flowserve Corporation  
Parallelweg 13  
4878 AH Etten-Leur  
The Netherlands  
Telephone: +31 76 502 8100



**Latin America**

Flowserve Corporation  
Martín Rodríguez 4460  
B1644CGN-Victoria-San Fernando  
Buenos Aires, Argentina  
Telephone: +54 11 4006 8700  
Telefax: +54 11 4714 1610

**Asia Pacific**

Flowserve Pte. Ltd.  
10 Tuas Loop  
Singapore 637345  
Telephone: +65 6771 0600  
Telefax: +65 6862 2329

*Your local Flowserve representative:*

**To find your local Flowserve representative,  
please use the Sales Support Locator System  
found at [www.flowserve.com](http://www.flowserve.com)  
or call: +1 937 890 5839.**