



TECHNICAL BULLETIN

Argus™ -C

FK 79C

FCD ARENTB0012-US-00-A4 8/16

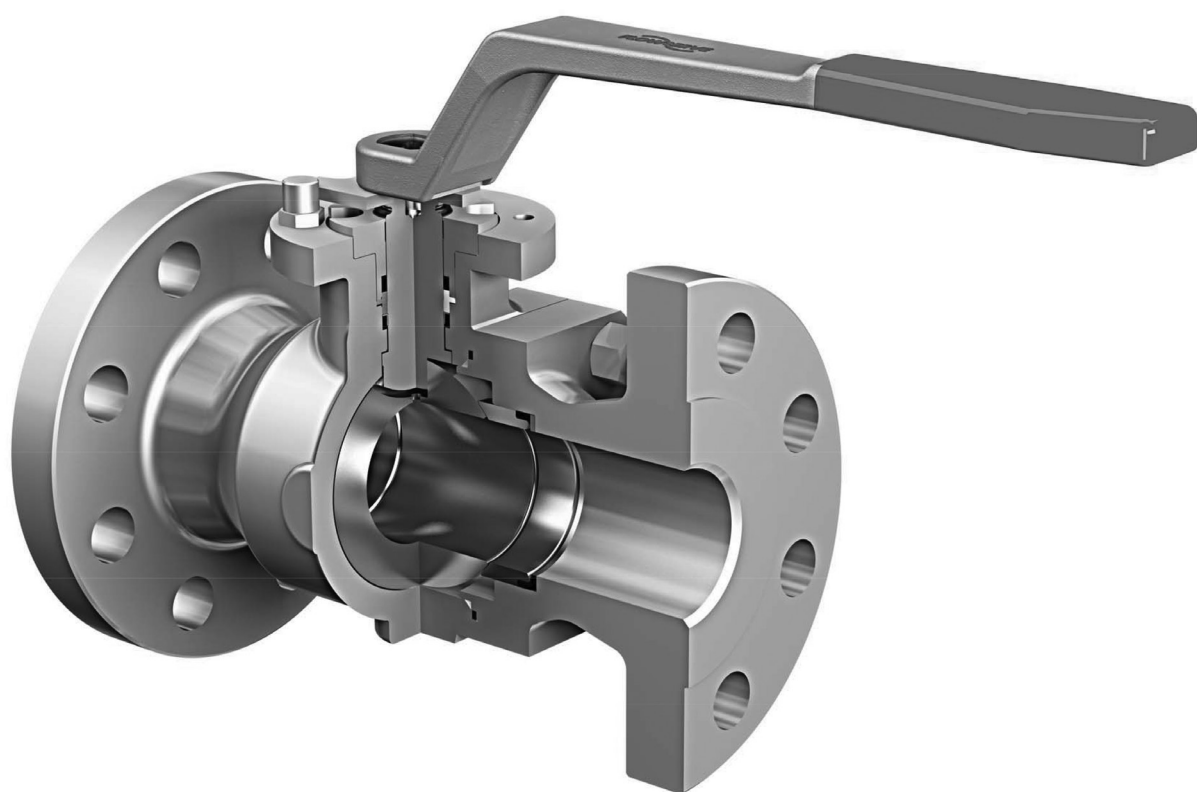

Ball Valve FK 79FC

Designed to meet ASME B16.34 (PED 97/23/EC optional) requirements, the FK 79FC ball valve represents the highest standards in valve technology. Its superfine finished seat-supported ball is just one of its many innovative design features.

Sizes

Sizes	DN½” – DN2”
ASME pressure classes	Class 150 – 300
Ends	RF

Technical Design Features

Designed to meet ASME B16.34 (PED 97/23/EC optional)

Materials: ASME Section II; Pressure / Temperature rating: ASME B16.34 / B16.15; Wall thickness:

ASME B16.34; Face to face dimensions: ASME B16.10; Flange connection ASME B16.5;

Split body, floating ball design, full bore, ends ASME B16.5

- Fire-safe according to ISO 10497
- Bi-directional, metal to metal sealing, ANSI B16.104 FCI 70-2 class VI
- Anti-blow out stem, long life double-stem seal system and stem supported in bearings to ensure seals are free from operation loads
- Stem sealing system according to EN ISO 15848
- Anti-static design according to DIN EN ISO 17292, chapter 5.2.7

Materials

Description	ASTM Material	Material DIN EN
Body	A352LCB	LCS Casting ADIN EN 1.6220
	A351 Gr.CF8M	SS DIN EN 1.4408
Ball	ASTM A182 F51 Crabide HVOF	Duplex DIN 1.4462 Crabide HVOF
Stem	A182 F51	Duplex DIN EN 1.4462
Stem seals		PTFE ; Graphite
Ball seats	ASTM A182 F51 Crabide HVOF	Duplex DIN 1.4462 Crabide HVOF
Body seals		PTFE ; Graphite
Bolts	A193 Gr. B7; A193 Gr. 8M	
Nuts	A194 Gr 4; A194 Gr. 8M	

Materials note: Crabide HVOF coating to perform ANSI B16.104 VCI 70-2 Class VI (high demand)

Crabide (ball and ball seats)

Crabide is a hard metal alloy based on chromium-carbide and nickel/chromium.

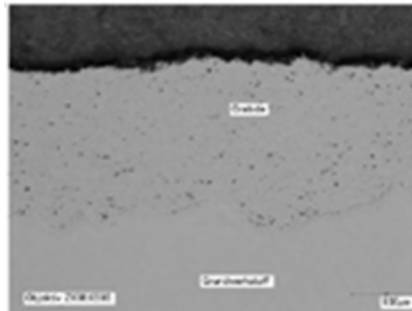

Composition	Cr ₂ C ₂ /Ni-Cr 75/25
Hardness	900 – 1100 HV _{0.3} (>67 HRC)
Temperature limit	Max. 970° (depending on base material and process conditions)
Thickness	200 – 300 µm (usual)
Chemical properties	Resistance versus media in the range of pH 5 and pH 12, as well under high temperature conditions
Mechanical properties	High resistance, especially against abrasion and adhesive wear and sliding abrasion

Sectional Drawing Serial FK 79FC

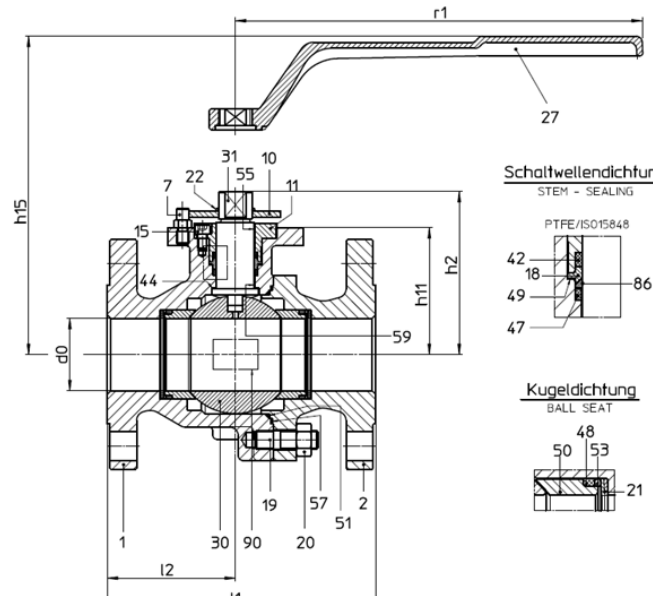

Dimensions

FK 79FC ASME Class 150

Investment casting

Inch	Flange	l1*	l2*	h2*	h11*	h15*	r1*	d0	Topwork DIN/ISO 5211
1/2	RF	108	49	65,5	45	117	220	15	F05
3/4	RF	117,5	54,5	66,5	46	118	220	20	F05
1	RF	127	57	67,5	47	119	220	25	F05
1 1/2	RF	165,1	75	101	76,5	150	270	38	F07
2	RF	177,8	85	108,5	84	157,5	270	48	F07

Note: * in mm

FK 79FC ASME Class 300

Investment casting

Inch	Flange	l1*	l2*	h2*	h11*	h15*	Sr1*	d0*	Topwork DIN/ISO 5211
1/2	RF	139,7	58	65,5	45	117	220	15	F05
3/4	RF	152,4	66	66,5	46	118	220	20	F05
1	RF	165,1	75	67,5	47	119	220	25	F05
1 1/2	RF	190,5	85	101	76,5	150	270	38	F07
2	RF	215,9	105	108,5	84	157,5	270	48	F07

Note: * in mm

Pressure / Temperature Rating

ARGUS Ball valve types: FK 79 FC

Body material:	Low temperature carbon steel			Stainless steel		
	DIN 1.6220	ASTM A 352 LCB		DIN 1.4408	ASTM A351 Gr. CF8M	
Seat design:	metal to metal resp. Graphite					
Temperature in °C	Max. operation pressure in barG					
	Class 150	Class 300	Class 600	Class 150	Class 300	Class 600
-29 * / 38 (remark)	18,4	48	96,0	19	49,6	99,3
50	18,2	47,5	94,9	18,4	48,1	96,2
100	17,4	45,3	90,7	16,2	42,2	84,4
150	15,8	43,9	87,9	14,8	38,5	77,0
200	13,8	42,5	85,1	13,7	35,7	71,3
Pressure /Temperature rating of our ball valve design is based on ASME B16.34 / 16.5						

Type/Drawings/Part Numbers

Class VI LOW DEMAND Chrome/Crabide

Type	DN	Class	Ends	Body	Material code	Sectional	Assembly	Topwork	DIN ISO	Order number
FK 79FC	15	150	RF	CS	1BDBD2D552	4M0905	4L3286	3Z0422	F05	795535
FK 79FC	20	150	RF	CS	1BDBD2D552	4M0906	4L3320	3Z0422	F05	795539
FK 79FC	25	150	RF	CS	1BDBD2D552	4M0784	4L3331	3Z0422	F05	795543
FK 79FC	40	150	RF	CS	1BDBD2D552	4M0785	4L3335	3Z0423	F07	795547
FK 79FC	50	150	RF	CS	1BDBD2D552	4M0785	4L3337	3Z0423	F07	795551
FK 79FC	15	150	RF	SS	1BDBD2D552	4M0905	4L3286	3Z0422	F05	795537
FK 79FC	20	150	RF	SS	1BDBD2D552	4M0906	4L3320	3Z0422	F05	795541
FK 79FC	25	150	RF	SS	1BDBD2D552	4M0784	4L3331	3Z0422	F05	795545
FK 79FC	40	150	RF	SS	1BDBD2D552	4M0785	4L3335	3Z0423	F07	795549
FK 79FC	50	150	RF	SS	1BDBD2D552	4M0785	4L3337	3Z0423	F07	795552
FK 79FC	15	300	RF	CS	1BDBD2D552	4M0790	4L3287	3Z0422	F05	795536
FK 79FC	20	300	RF	CS	1BDBD2D552	4M0789	4L3321	3Z0422	F05	795540
FK 79FC	25	300	RF	CS	1BDBD2D552	4M0788	4L3332	3Z0422	F05	795544
FK 79FC	40	300	RF	CS	1BDBD2D552	4M0796	4L3336	3Z0423	F07	795548
FK 79FC	50	300	RF	CS	1BDBD2D552	4M0797	4L3338	3Z0423	F07	795552
FK 79FC	15	300	RF	SS	1BDBD2D552	4M0790	4L3287	3Z0422	F05	795538
FK 79FC	20	300	RF	SS	1BDBD2D552	4M0789	4L3321	3Z0422	F05	795542
FK 79FC	25	300	RF	SS	1BDBD2D552	4M0788	4L3332	3Z0422	F05	795546
FK 79FC	40	300	RF	SS	1BDBD2D552	4M0796	4L3336	3Z0423	F07	795550
FK 79FC	50	300	RF	SS	1BDBD2D552	4M0797	4L3338	3Z0423	F07	795554

Standard Topwork Drawings

FK 79FC serial index AE DN 15 + 20; serial index AB DN 25 + 32 (3Z0422)

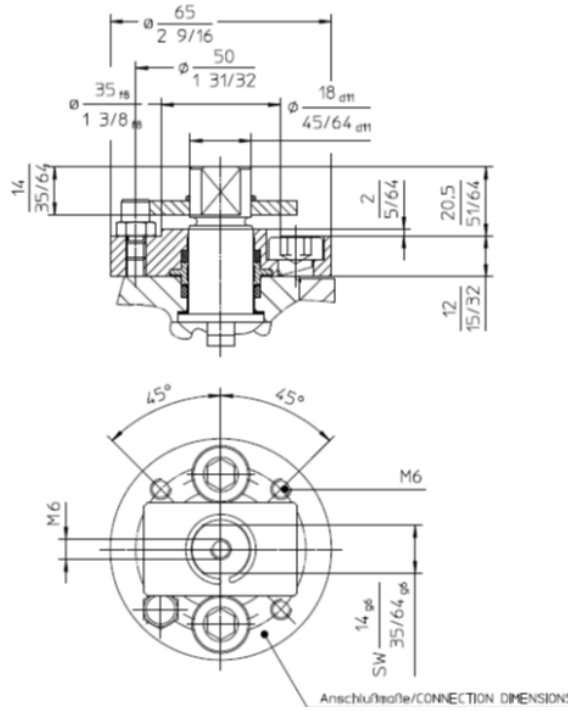

FK 79FC serial index AB DN 40 + 50 (3Z0443)

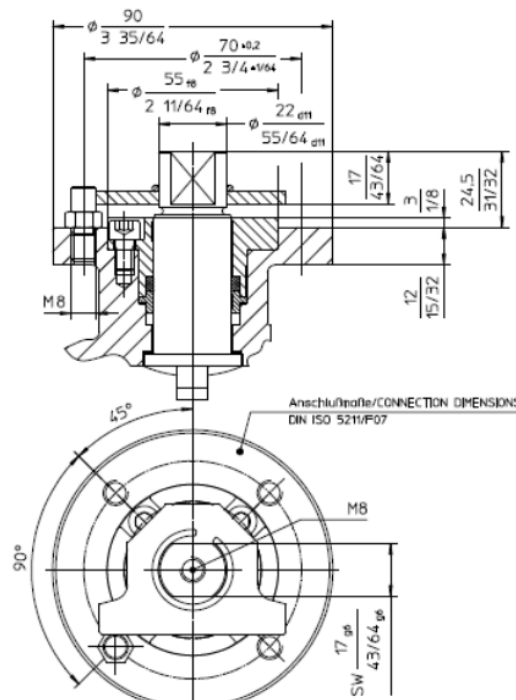

Torque Tables

Pressure Class: #150		
Seat system: bidirectional "M"		
Pressure (bar)	DN15 (Nm)	DN20 (Nm)
8	22	31
10	23	32
12,5	24	33
16	25	35
20	27	38

Pressure Class: #150 and #300					
Seat system: bidirectional "N" (*not available in pressure class #150)					
Pressure (bar)	DN15* (Nm)	DN20* (Nm)	DN25 (Nm)	DN40 (Nm)	DN50 (Nm)
8	18	25	30	51	82
10	18	26	31	52	84
12,5	18	26	32	55	87
16	18	27	33	57	91
20	19	27	35	61	96
25	19	28	37	65	102
32	20	29	39	71	110
40	20	30	42	78	120
50	21	32	46	86	132

Values Included

Metal seated: Chrome / Crabide

Stem sealing system: ISO15848

Additional Multiplication Factors

Application

Daily operation: 1,0

Operation after longer periods of disuse (≥ 2 days): 1,1

Operation after longer periods of disuse (≥ 5 days): 1,2

Media

Lubricating: 1,0

Non-lubricating: 1,3

Example:

DN25 / differential pressure 32 bar / operation every 3 days / lubricating media

$Md = 39 \text{ Nm} \times 1,1 \times 1,0 = 43 \text{ Nm}$



Flowserve Flow Control
Rudolf-Plank-Straße 2 D-76275
Ettlingen, Germany
T: +49 7243 103-0

Flowserve Corporation
3993 W. Sam Houston
Parkway North
Suite 100
Houston, TX 77043
Tel: +1 281 469 4166

FCD ARENTB0012-US-00-A4 Printed in the USA. August 2016

To find your local Flowserve representative

or for more information about Flowserve Corporation,
visit www.flowserve.com or call USA 1 800 225 6989

Flowserve Corporation has established industry leadership in the design and manufacture of its products. When properly selected, this Flowserve product is designed to perform its intended function safely during its useful life. However, the purchaser or user of Flowserve products should be aware that Flowserve products might be used in numerous applications under a wide variety of industrial service conditions. Although Flowserve can (and often does) provide general guidelines, it cannot provide specific data and warnings for all possible applications. The purchaser/user must therefore assume the ultimate responsibility for the proper sizing and selection, installation, operation, and maintenance of Flowserve products. The purchaser/user should read and understand the Installation Operation Maintenance (IOM) instructions included with the product, and train its employees and contractors in the safe use of Flowserve products in connection with the specific application.

While the information and specifications contained in this literature are believed to be accurate, they are supplied for informative purposes only and should not be considered certified or as a guarantee of satisfactory results by reliance thereon. Nothing contained herein is to be construed as a warranty or guarantee, express or implied, regarding any matter with respect to this product. Because Flowserve is continually improving and upgrading its product design, the specifications, dimensions and information contained herein are subject to change without notice. Should any question arise concerning these provisions, the purchaser/user should contact Flowserve Corporation at any one of its worldwide operations or offices.

© 2016 Flowserve Corporation, Irving, Texas, USA. Flowserve is a registered trademark of Flowserve Corporation.