

Limitorque™
LDG Direct Gas Heavy-Duty Actuator Series

FCD LFENTB0005-00-AQ - 06/16

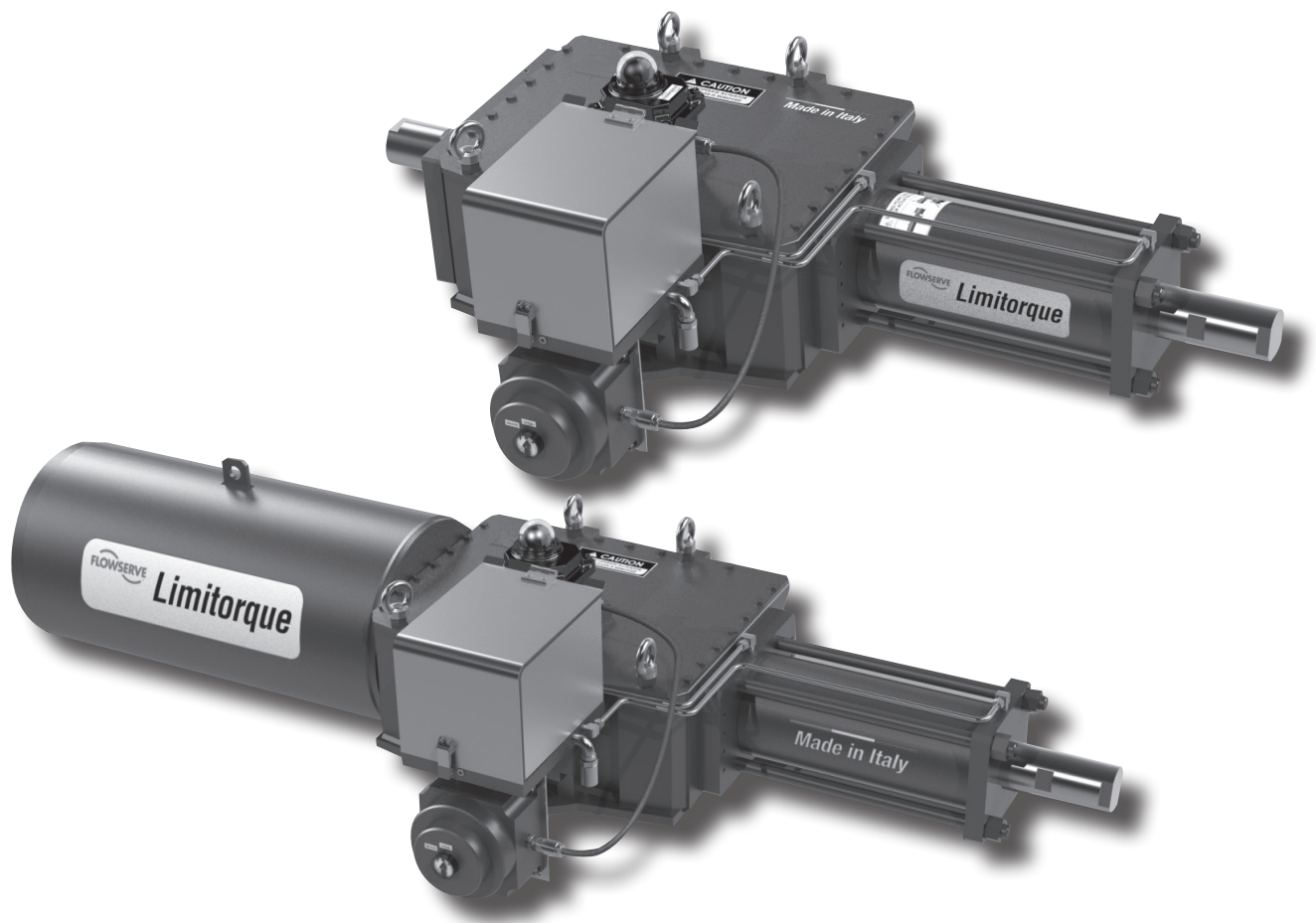

Contents

LDG Series Hydraulic Heavy-Duty Actuator Specifications.....	4
Actuator Selection Table	6
Actuator Selection Guidance.....	6
1 Scope.....	6
2 General Definitions/Terms Used	6
3 Inputs for Sizing Hydraulic Scotch Yoke Actuators	7
4 Manual Overrides.....	9
5 Single Action and Double Action Configurations	10
6 Dimensions.....	11
7 Disclaimer.....	11
Dimensional Data and Weights – Single Acting.....	12
Dimensional Data and Weights – Double Acting.....	24
MHPC - Dimensions	25
Mounting Interface Dimensions.....	87
Service Kits.....	29

LDG Series Direct Gas Heavy-Duty Actuator Specifications

1. The LDG range of Limitorque Direct Gas Actuators is a robust, modular scotch yoke design, available in both spring return and double acting configurations. It is suitable for actuating ball, butterfly and plug valves or any other quarter-turn application.
2. LDG Direct Gas actuators deliver up to 300 kNm* (221 000 ft-lb) of precisely controlled torque. LDG Limitorque Direct Gas Actuator is part of Limitorque Fluid Power Systems family of heavy-duty scotch yoke actuators. The same design philosophy introduced on heavy-duty LPS actuators has been adopted for the LDG range, bringing enhanced performance and reliability.
3. To complete the actuation package, LDG actuators are supplied with the on board Medium-High Pressure Control Group (MHPC) including both local and remote operation configurations and multiple optional functionalities are available to meet all pipeline applications. The Limitorque engineering team can also design custom solutions for the most complex customer requirements.
4. Limitorque provides engineering design services for mounting hardware, ensuring that your actuation solution is ready to handle the toughest challenges.
5. The LDG actuator is designed to provide a 25-year design life, depending on service conditions, proper installation, operation and maintenance. In order to achieve this industry-leading design life, in-field maintenance is prescribed to be performed every 6 years of operation. For high-cycle applications, more frequent maintenance of replaceable wear surfaces, as outlined in EN 15714, may be required.
6. Suitable for use in on/off, modulating and isolating valve application in general service, protective service and safety applications such as ESD or HIPPS.
7. Available valve interface in compliance with **ISO 5211** or **MSS SP-101**, upon request as an option.
8. Manufactured and tested in compliance with **EN 15714-3** and **ISO 12490**.
9. Spring components are designed in compliance with **EN 13906-1**.
10. Surface coating and corrosion protection in compliance with **ISO 12944-2** up to and including **C5-M** if requested.
11. Environmental resistance has been certified to meet or exceed the requirements of **IEC 60529** up to and including **1P66/66M and IP67/67M**.
12. The LDG actuator is suitable for use in Safety Integrated Systems in accordance with **IEC 61508** up to and including **SIL Level 3**.
13. The actuators in the LDG series meet the requirements of **ISO 5599-2**.
14. LDG actuators are available in accordance with **ATEX 94/9/EC Ex II 2GD c IIC T6**, as it relates to mechanical actuators.
15. Actuators are available in compliance with **NACE** specification **MR0175** for sour gas applications
16. Shaft-driven accessories/devices are directly mounted to **VDE VDI 3845 NAMUR** compliant mounting locations.
17. The actuator is manufactured and tested in compliance with an **ISO 9001** Quality Assurance Program.
18. Integral travel stops provide **90°±5°** of stroke adjustment and are designed for the MAWP of the actuator, up to 105 barg (1500 psig)
19. The materials of construction and seals of the LDG family of actuators are available for a wide range of service temperatures, including **Tropical, Arid, Temperate, Cold and Polar** regions in accordance with **IEC 60721**.
20. The high pressure pneumatic cylinder design features proven and reliable external tie rods suitable for continuous duty service at the maximum rated pressure. Wear and corrosion protection of all components is ensured with suitable treatments and coatings. **ENP** (electro less nickel plating) is the standard for the internal surface of the high pressure pneumatic cylinder to ensure complete sealing and superior corrosion resistance. Other coatings for the internal surface of the cylinder are available upon request.
21. Pressure modules are available in compliance with:
 - a. Pressure Equipment Directive 97/23/EC**
 - b. ASME BPVC Sec. VIII, Div. 1**
 - c. EN 13445-3, Part 3 for Unfired Pressure Vessels**
22. All actuators and modules meet acceptance criteria defined by Flowserve test specifications. High pressure pneumatic cylinder cylinders can be tested as stand-alone modules prior to assembly or in case of stocking or retrofitting.

* Contact factory for larger sizes and higher output torques.

23. The actuator is provided with two full-length key slots in the yoke suitable for mounting in alternate orientations (horizontally or vertically – parallel or perpendicular to the piping system).
24. The LDG is available with either a symmetric or canted scotch yoke. Scotch yoke cants are available from 1° to 15° upon request, pending on application.
25. All modules align and mate with close-tolerance machined flanges with no exposed threaded connections.
26. The high-strength, heat-treated alloy steel guide bar is hard chrome plated for wear and corrosion protection.
27. Piston rods are designed to handle lateral loads to effectively minimize deflection. The piston rod is detachable from the torque module without special tools and does not require module disassembly.
28. Pressure seals utilize O-rings, quad-rings or V-rings as appropriate to eliminate environmental ingress. No gaskets are used in pressurized regions of the actuator.
29. The push-to-compress springs are safely enclosed and welded and are positively retained on the torque module under all load conditions. No external tie rods/braces are required to contain the springs. Springs are designed in accordance with **EN 13906-1** and combined and positioned to eliminate potential contact with the container or each other in the case of multiple springs. Springs are shot peened for maximum life and are painted and permanently lubricated coated prior to assembly to eliminate corrosion.
30. The spring and spring guide are self-centered and bearing guided within the spring module. The spring rod is guided in a self-lubricating bearing and connected to the torque module through a large pinned connection designed for safe operation at all load conditions. Installation and removal of the spring module does not require special tools.
31. Maintenance-free, self-lubricating bearings are used to minimize friction of the yoke, yoke-pins and slider blocks in the yoke slots for low friction and to minimize contact stresses in order to provide the longest possible service life.
32. Retention of the yoke pin is by a single plate to permit easy removal of the yoke pin and slider blocks while the actuator is mounted in the valve. No specialized tools are required.
33. LDG Medium-High Pressure Control group (MHPC) is mounted on-board the actuator within a dedicated enclosure in 316 stainless steel.
34. MHPC group includes an integral terminal board and piping manifold simplifying piping and wiring assembly and minimising leak paths in gas control circuit.
35. Main control components, terminal box and manifold build is anodized aluminium
36. Control components include solenoid and/or manually operated valves (depending on specific customer requirement) for on-off local or remote operation, shuttle valve allowing pressure uptake upstream or downstream of valve, and compact LFPS design dehydrating filter.
37. Control components are all rated for full system pressure of up to 105 barg/1500 psig. Full pressure rating of controls and actuator power cylinder eliminates need for pressure reducer, reducing system complexity, eliminating risks of gas condensation and freezing, allowing higher torque output with smaller overall dimensions and reducing gas use and exhaust
38. Control group is certified IP66, Atex II GD, Ex-d-IIC T6, IECex.

Actuator Selection Table

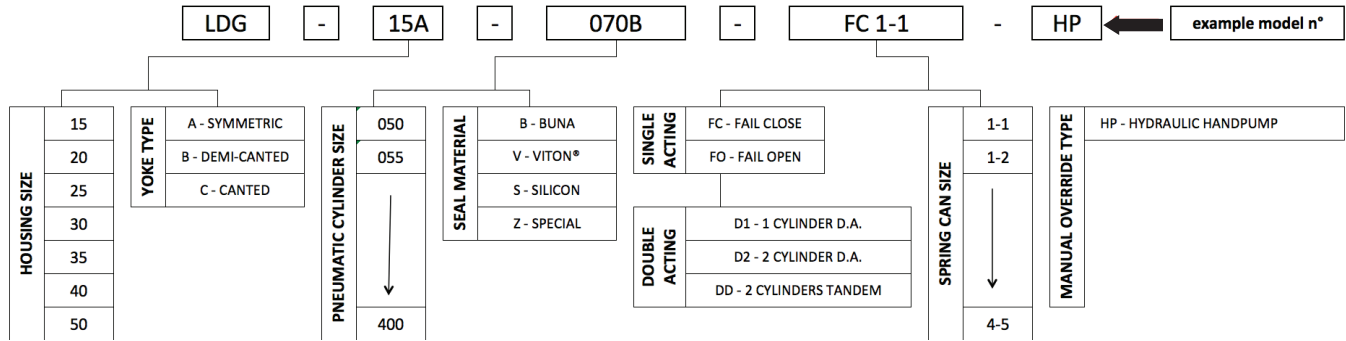

Seals Material

Code	Material	Temperature Range	Climate Classification according to IEC60721
B	Buna	Std Temp: -29°C to +100°C (-20°F to 212°F)	Tropical & Arid
V	Viton®	Hi Temp: up to +160°C (320°F)	Tropical & Arid
S	Silicon	Low Temp: down to -40°C (-40°F)	Temperate
Z	Other	Special Applications: Consult Factory	Cold & Polar

Actuator Selection Guidance

1. Scope

This section provides guidance for the selection of the proper LDG actuator to suit specific operational requirements. A basic understanding of scotch yoke actuators and the typical applications in which they are used is provided in order to assist in selection of the most suitable actuator. While the selection procedures and product data contained herein cover many applications, due to the

wide range of applications in which the LDG actuators can be used, this information will not cover every set of operational requirements. The Limitorque applications team is always available to assess specific applications and help with selection of the appropriate LDG actuators. Please contact your local office for assistance.

2. General Definitions/Terms Used

Quarter-turn	A device that rotates by a nominal 90°. LDG series actuators rotate $\pm 5^\circ$ more than the nominal 90°.
Position	The degree of rotation describing an actuator's current location, the zero being referred from complete counter-clockwise position of the yoke. The mid-position of the actuator is at 45° and 90° being the end of clockwise stroke.
CW	Clockwise rotation.
CCW	Counter-clockwise rotation.
Stroke	A continuous, 90° rotation of a quarter-turn actuator.
Cycle	Two strokes, one clockwise (CW) rotation and other counter-clockwise (CCW) rotation, constitute one cycle of operation of the actuator.

*Viton is a registered trademark of E. I. du Pont de Nemours.

Safety Factor	A factor multiplied by the valve's basic required torque value to increase the amount of torque required to meet safety requirements in a given application. When the valve's torque requirements are not known with certainty, or due to other application demands, use of a safety factor is required in the selection process in order to meet the worst-case torque requirements.
Pneumatic Break Torque	Output torque when the actuator is in the position to start the pressure stroke. [The torque required to initiate the pressure stroke.]
Pneumatic End Torque	Output torque at the end limit of the pressure stroke. [The torque required to seat the valve at the end of the pressure stroke.]
Run Torque	The output torque recorded while the actuator is in the mid-position of the pressure stroke (45°). For symmetrical yoke double-acting actuators, this is the minimum torque output obtained during the complete stroke.
Spring Break Torque	The output torque when the actuator is in the position to start the spring stroke. [The torque required to initiate the spring stroke.] The spring is fully compressed at this position and generates the maximum spring force.
Spring End Torque	The output torque when the actuator has reached the end limit of spring stroke. [The torque required to seat the valve at the end of the spring stroke.] The spring is fully extended at this position and generates the minimum spring force.
Minimum Torque	The output torque at an intermediate position of the spring stroke, where the output torque of the actuator is at its lowest value.
MOP	Maximum operating pressure of an actuator

3. Inputs for Sizing Gas Powered Scotch Yoke Actuators

Due to the scotch yoke mechanism, LDG actuators have a particular U-shaped output torque curve whether powered by a fixed supply pressure or the spring.

In sizing of actuators powered directly by pipeline gas, care must be taken to evaluate the valve torque requirements against the actuator output torques at the varying pressures in the actual pipeline.

For a proper actuator model selection, the safety factors between actuator output torque and valve torque requirement shall be calculated at least in six points along the valve stroke, and as minimum, at the minimum and maximum pipeline normal operating pressures.

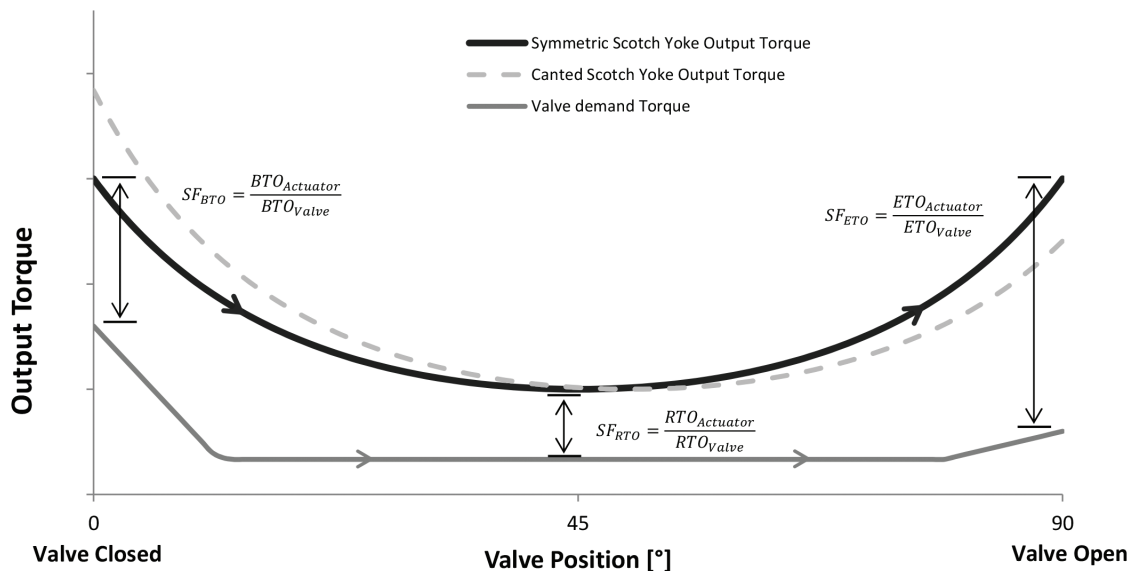

Figure 1: Actuator OPEN (by fluid) Torque Curve: Single Acting Spring Return – Fail Close (CW)

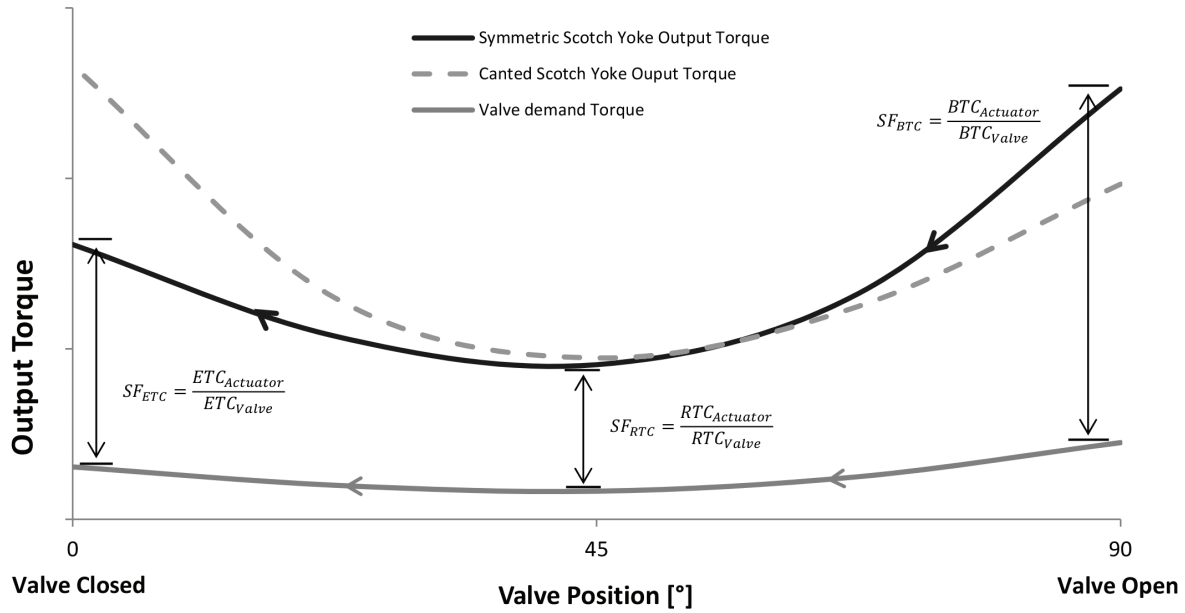

Figure 2: Actuator CLOSE (by spring) Torque Curve: Single Acting Spring Return – Fail Close (CW)

The minimum set of parameters and features necessary for an optimal actuator selection:

- Valve torques at minimum and maximum pipeline pressure, including MAST
- Type of actuator:
 - Single Acting/Spring Return: Fail Safe Close (CW) or Fail Safe Open (CCW)
 - Double Acting configuration for Fail Last or Fail As Is
- Minimum and Maximum gas supply pressure to the actuator
- Gas composition (H2S content) in case of sour gas applications
- Safety Factors requested by the project or by a specific application
- Working Temperature range
- Open/Close stroking times
- Additional options (manual override, limit switches, specific functional requirements such as line-break, low or high pressure trip, etc, others as applicable)

Definitions:

- BTO = Break to Open torque
- BTC = Break to Close torque
- RTO = Running to Open torque
- RTC = Running to Close torque
- ETO = End to Open torque
- ETC = End to Close torque
- MAST = Maximum Allowable Stem Torque
- SF = Safety Factor

4. LDG Manual Overrides

Manual overrides are necessary to allow operation of the valve actuators whenever motive pressure and/or electrical power are not available. All LDG models can be fitted with an optional manual override system through a hydraulic handpump. Limitorque hydraulic manual overrides are designed in accordance with EN 12570 and are available for both single acting (spring-return) and double acting actuator versions.

The hydraulic chamber of the handpump is completely segregated from the gas cylinder of the actuator to avoid any possibility of fluid contamination and frothing phenomenon

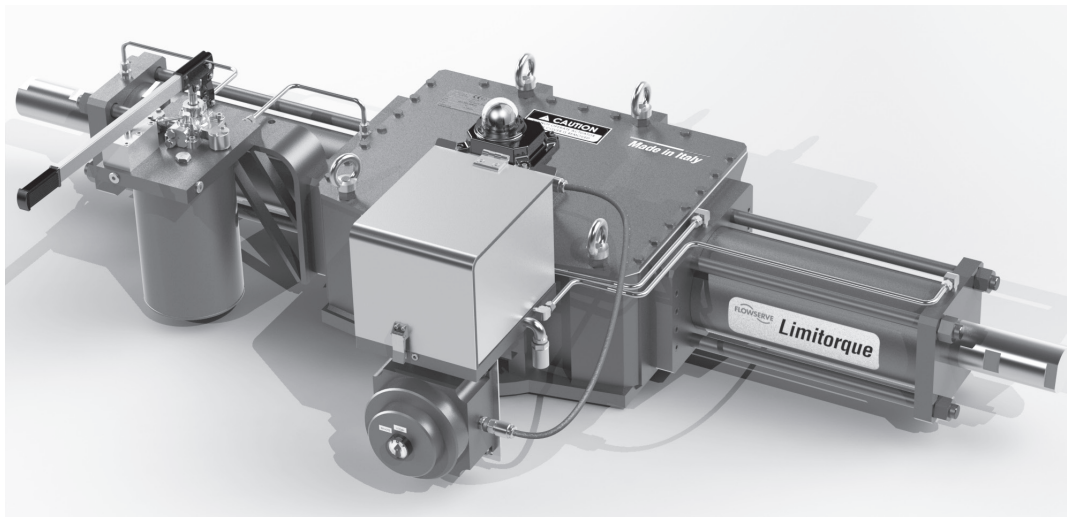

Figure 3: Manual Overrides

5. Single Action and Double Action Configurations

The LDG actuator is designed for work in both single acting (fail open and fail close) and double acting configurations:

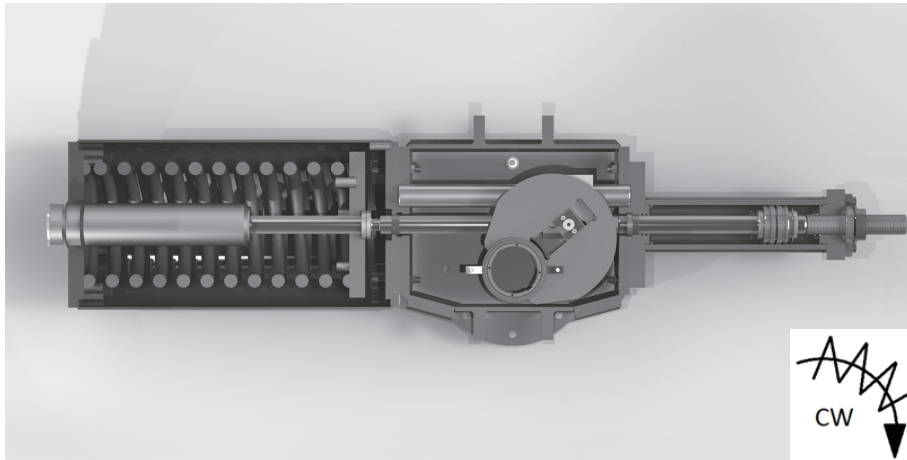

Figure 4: Single Acting Actuator Configuration: Fail Close – Fail Clockwise

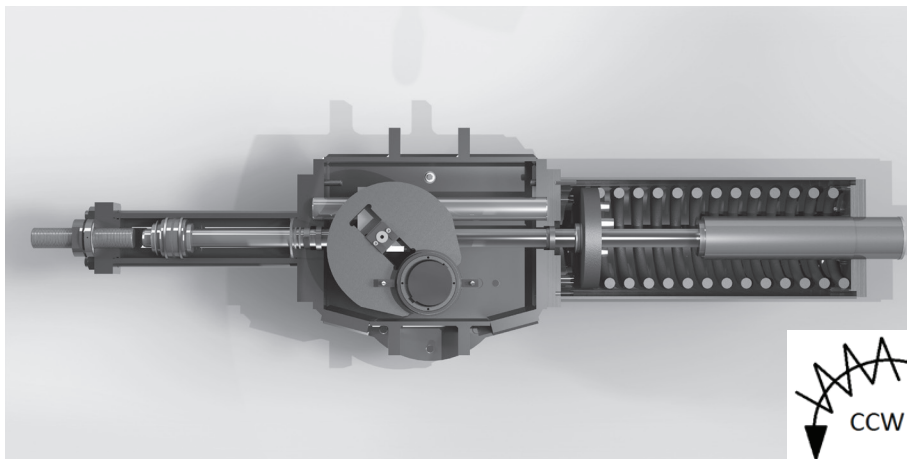

Figure 5: Single Acting Actuator Configuration: Fail Open – Fail Counterclockwise

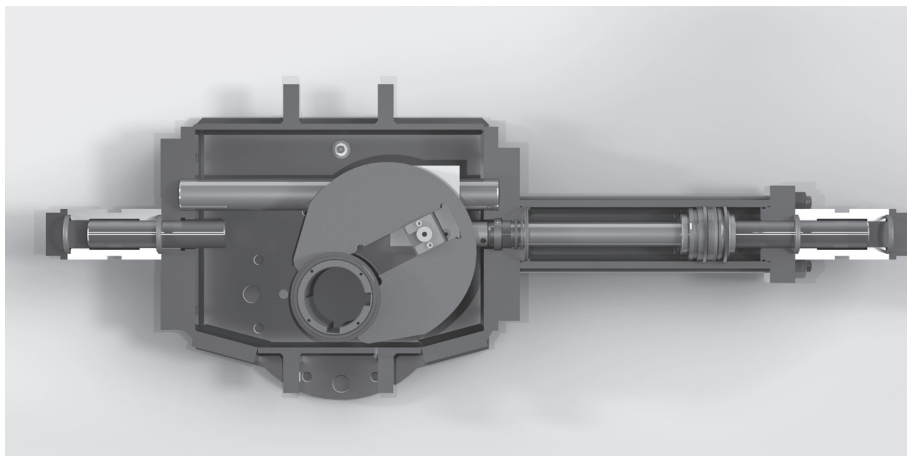

Figure 6: Double Acting Actuator Configuration – Close Position

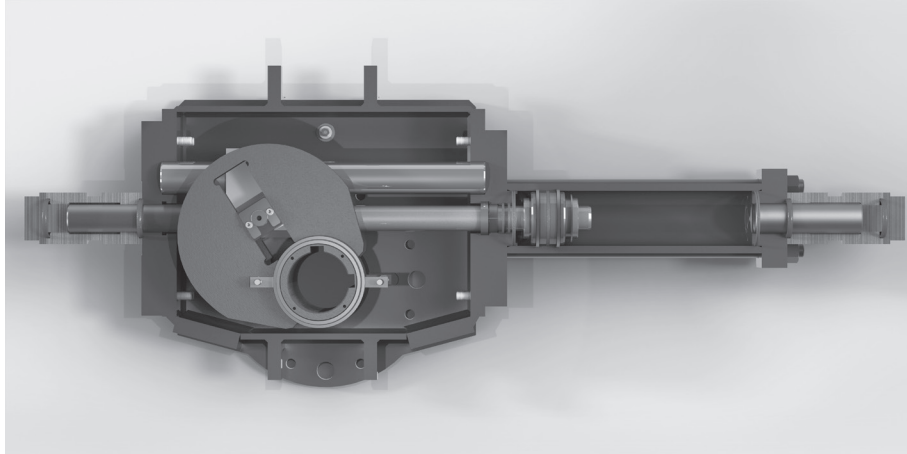

Figure 7: Double Acting Actuator Configuration – Open Position

6. Dimensions

The following Dimensions & Weight tables include main external dimensions referred to the relevant pictures included in each section. The overall lengths, the weights, the mounting dimension details, the interface dimensions and the tolerances are included as a guide for actuator selection.

The stated dimensions and weights include the actuators only, without any optional features, like the spool pieces, manual overrides etc.

The weight of MHPC group is given separately, in the base versions for single and double acting actuators. Weights and dimensions of MHPC may vary depending on functions requested.

Note: Performance data for LDG actuators is available upon request. For correct selection of LDG actuators, consult Limitorque Flowserve Application Engineers or local Sales Support.

7. Disclaimer

This publication is presented for information purposes only, with an effort to ensure the accuracy, the contents are not to be construed as warranties or guarantees, expressed or implied, regarding the products or services described herein or their use or applicability. The right to modify or improve the designs or specifications of our products at any time without notice is reserved.

LDG Dimensional Data and Weights – Single Acting

Figure 8: Dimensional Data – Single Acting – Sym/Cant – Fail Close

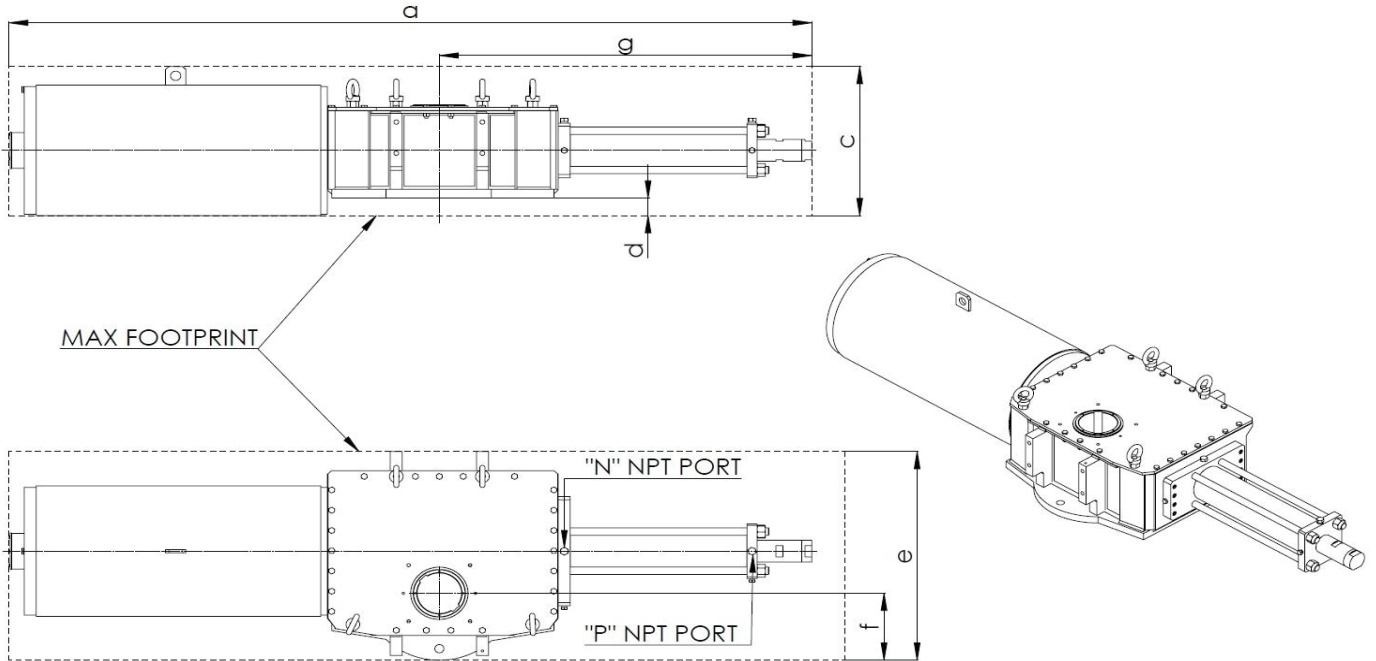
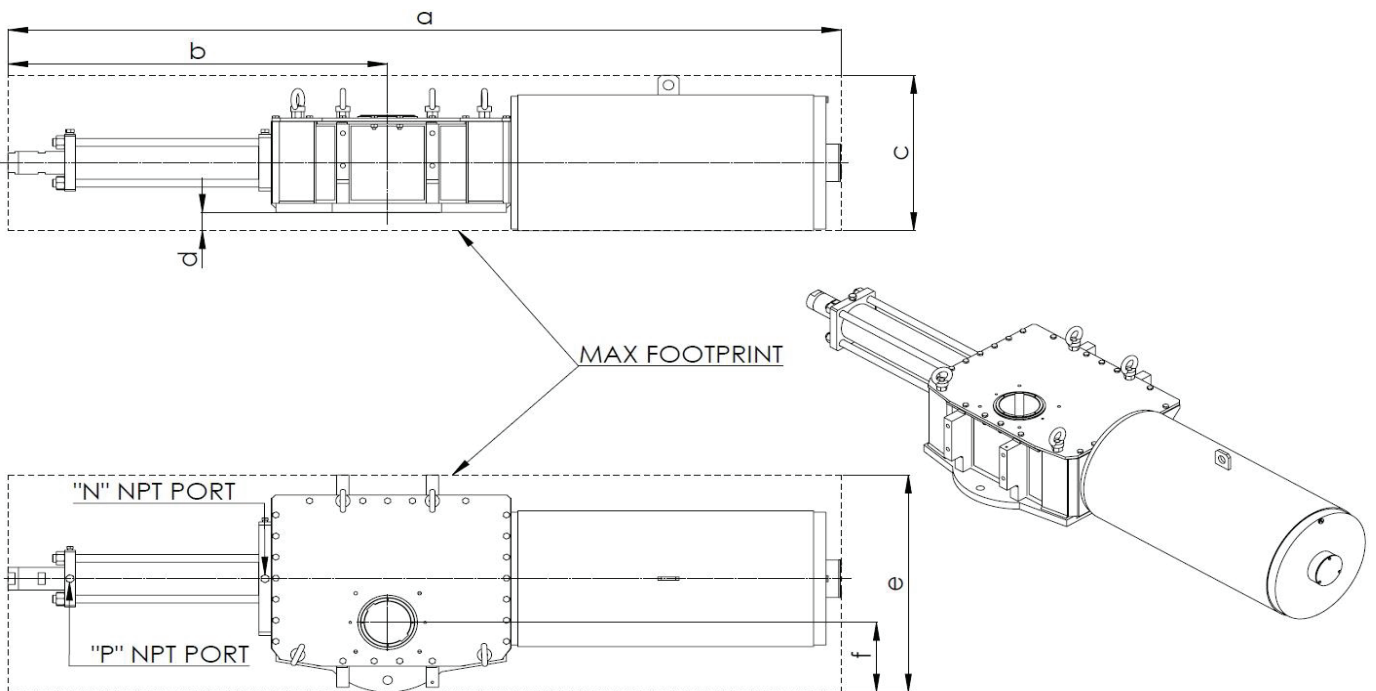

Figure 9: Dimensional Data – Single Acting – Sym/Cant – Fail Open





Limitorque™ LDG Direct Gas Heavy-Duty Actuator Series FCD LFENTB0005-00-AQ - 06/16

LDG Single Acting - Dimensions: mm (in) - Weights: Kg (lbs) - Swept Volumes: l (cu in) - MOT: Nm (ft-lb)													
Model		a	b	c	d	e	f	g	"P" NPT PORT	"N" NPT PORT	Weight	Swept Volume*	MOT
LDG-15X-050Y-FC1-2	LDG-15X-050Y-FO1-2	1176	470	289	23	352	120	480	2 x 1/2"	2 x 1/2"	126	0,3	6000
		46,3	18,5	11,4	0,9	13,9	4,7	18,9			277	18	4425
LDG-15X-060Y-FC1-2	LDG-15X-060Y-FO1-2	1176	470	289	23	352	120	480	2 x 1/2"	2 x 1/2"	128	0,4	6000
		46,3	18,5	11,4	0,9	13,9	4,7	18,9			282	24	4425
LDG-15X-070Y-FC1-2	LDG-15X-070Y-FO1-2	1176	470	289	23	352	120	480	2 x 1/2"	2 x 1/2"	131	0,5	6000
		46,3	18,5	11,4	0,9	13,9	4,7	18,9			288	31	4425
LDG-15X-080Y-FC1-2	LDG-15X-080Y-FO1-2	1176	470	289	23	352	120	480	2 x 1/2"	2 x 1/2"	133	0,7	6000
		46,3	18,5	11,4	0,9	13,9	4,7	18,9			293	43	4425
LDG-15X-090Y-FC1-2	LDG-15X-090Y-FO1-2	1176	470	289	23	352	120	480	2 x 1/2"	2 x 1/2"	138	0,9	6000
		46,3	18,5	11,4	0,9	13,9	4,7	18,9			303	55	4425
LDG-15X-100Y-FC1-2	LDG-15X-100Y-FO1-2	1176	470	289	23	352	120	480	2 x 1/2"	2 x 1/2"	140	1,1	6000
		46,3	18,5	11,4	0,9	13,9	4,7	18,9			309	67	4425
LDG-15X-110Y-FC1-2	LDG-15X-110Y-FO1-2	1209	503	289	23	352	120	513	2 x 1/2"	2 x 1/2"	143	1,3	6000
		47,6	19,8	11,4	0,9	13,9	4,7	20,2			314	79	4425
LDG-15X-120Y-FC1-2	LDG-15X-120Y-FO1-2	1214	508	289	23	352	120	518	2 x 1/2"	2 x 1/2"	145	1,5	6000
		47,8	20,0	11,4	0,9	13,9	4,7	20,4			320	92	4425
LDG-15X-050Y-FC1-3	LDG-15X-050Y-FO1-3	1176	470	289	23	352	120	480	2 x 1/2"	2 x 1/2"	126	0,3	6000
		46,3	18,5	11,4	0,9	13,9	4,7	18,9			277	18	4425
LDG-15X-060Y-FC1-3	LDG-15X-060Y-FO1-3	1176	470	289	23	352	120	480	2 x 1/2"	2 x 1/2"	128	0,4	6000
		46,3	18,5	11,4	0,9	13,9	4,7	18,9			282	24	4425
LDG-15X-070Y-FC1-3	LDG-15X-070Y-FO1-3	1176	470	289	23	352	120	480	2 x 1/2"	2 x 1/2"	131	0,5	6000
		46,3	18,5	11,4	0,9	13,9	4,7	18,9			288	31	4425
LDG-15X-080Y-FC1-3	LDG-15X-080Y-FO1-3	1176	470	289	23	352	120	480	2 x 1/2"	2 x 1/2"	133	0,7	6000
		46,3	18,5	11,4	0,9	13,9	4,7	18,9			293	43	4425
LDG-15X-090Y-FC1-3	LDG-15X-090Y-FO1-3	1176	470	289	23	352	120	480	2 x 1/2"	2 x 1/2"	138	0,9	6000
		46,3	18,5	11,4	0,9	13,9	4,7	18,9			303	55	4425
LDG-15X-100Y-FC1-3	LDG-15X-100Y-FO1-3	1176	470	289	23	352	120	480	2 x 1/2"	2 x 1/2"	140	1,1	6000
		46,3	18,5	11,4	0,9	13,9	4,7	18,9			309	67	4425
LDG-15X-110Y-FC1-3	LDG-15X-110Y-FO1-3	1209	503	289	23	352	120	513	2 x 1/2"	2 x 1/2"	143	1,3	6000
		47,6	19,8	11,4	0,9	13,9	4,7	20,2			314	79	4425
LDG-15X-120Y-FC1-3	LDG-15X-120Y-FO1-3	1214	508	289	23	352	120	518	2 x 1/2"	2 x 1/2"	145	1,5	6000
		47,8	20,0	11,4	0,9	13,9	4,7	20,4			320	92	4425
LDG-15X-060Y-FC2-1	LDG-15X-060Y-FO2-1	1176	470	384	71	352	120	480	2 x 1/2"	2 x 1/2"	162	0,4	6000
		46,3	18,5	15,1	2,8	13,9	4,7	18,9			357	24	4425
LDG-15X-070Y-FC2-1	LDG-15X-070Y-FO2-1	1176	470	384	71	352	120	480	2 x 1/2"	2 x 1/2"	165	0,5	6000
		46,3	18,5	15,1	2,8	13,9	4,7	18,9			363	31	4425
LDG-15X-080Y-FC2-1	LDG-15X-080Y-FO2-1	1176	470	384	71	352	120	480	2 x 1/2"	2 x 1/2"	167	0,7	6000
		46,3	18,5	15,1	2,8	13,9	4,7	18,9			368	43	4425
LDG-15X-090Y-FC2-1	LDG-15X-090Y-FO2-1	1176	470	384	71	352	120	480	2 x 1/2"	2 x 1/2"	172	0,9	6000
		46,3	18,5	15,1	2,8	13,9	4,7	18,9			378	55	4425
LDG-15X-100Y-FC2-1	LDG-15X-100Y-FO2-1	1176	470	384	71	352	120	480	2 x 1/2"	2 x 1/2"	174	1,1	6000
		46,3	18,5	15,1	2,8	13,9	4,7	18,9			384	67	4425
LDG-15X-110Y-FC2-1	LDG-15X-110Y-FO2-1	1209	503	384	71	352	120	513	2 x 1/2"	2 x 1/2"	177	1,3	6000
		47,6	19,8	15,1	2,8	13,9	4,7	20,2			389	79	4425
LDG-15X-120Y-FC2-1	LDG-15X-120Y-FO2-1	1214	508	384	71	352	120	518	2 x 1/2"	2 x 1/2"	179	1,5	6000
		47,8	20,0	15,1	2,8	13,9	4,7	20,4			395	92	4425
LDG-15X-070Y-FC2-2	LDG-15X-070Y-FO2-2	1176	470	384	71	352	120	480	2 x 1/2"	2 x 1/2"	180	0,5	6000
		46,3	18,5	15,1	2,8	13,9	4,7	18,9			396	31	4425
LDG-15X-080Y-FC2-2	LDG-15X-080Y-FO2-2	1176	470	384	71	352	120	480	2 x 1/2"	2 x 1/2"	182	0,7	6000
		46,3	18,5	15,1	2,8	13,9	4,7	18,9			401	43	4425
LDG-15X-090Y-FC2-2	LDG-15X-090Y-FO2-2	1176	470	384	71	352	120	480	2 x 1/2"	2 x 1/2"	187	0,9	6000
		46,3	18,5	15,1	2,8	13,9	4,7	18,9			411	55	4425
LDG-15X-100Y-FC2-2	LDG-15X-100Y-FO2-2	1176	470	384	71	352	120	480	2 x 1/2"	2 x 1/2"	189	1,1	6000
		46,3	18,5	15,1	2,8	13,9	4,7	18,9			417	67	4425
LDG-15X-110Y-FC2-2	LDG-15X-110Y-FO2-2	1209	503	384	71	352	120	513	2 x 1/2"	2 x 1/2"	192	1,3	6000
		47,6	19,8	15,1	2,8	13,9	4,7	20,2			422	79	4425
LDG-15X-120Y-FC2-2	LDG-15X-120Y-FO2-2	1214	508	384	71	352	120	518	2 x 1/2"	2 x 1/2"	194	1,5	6000
		47,8	20,0	15,1	2,8	13,9	4,7	20,4			428	92	4425
LDG-15X-070Y-FC2-3	LDG-15X-070Y-FO2-3	1176	470	384	71	352	120	480	2 x 1/2"	2 x 1/2"	180	0,5	6000
		46,3	18,5	15,1	2,8	13,9	4,7	18,9			396	31	4425
LDG-15X-080Y-FC2-3	LDG-15X-080Y-FO2-3	1176	470	384	71	352	120	480	2 x 1/2"	2 x 1/2"	182	0,7	6000
		46,3	18,5	15,1	2,8	13,9	4,7	18,9			401	43	4425
LDG-15X-090Y-FC2-3	LDG-15X-090Y-FO2-3	1176	470	384	71	352	120	480	2 x 1/2"	2 x 1/2"	187	0,9	6000
		46,3	18,5	15,1	2,8	13,9	4,7	18,9			411	55	4425
LDG-15X-100Y-FC2-3	LDG-15X-100Y-FO2-3	1176	470	384	71	352	120	480	2 x 1/2"	2 x 1/2"	189	1,1	6000
		46,3	18,5	15,1	2,8	13,9	4,7	18,9			417	67	4425
LDG-15X-110Y-FC2-3	LDG-15X-110Y-FO2-3	1209	503	384	71	352	120	513	2 x 1/2"	2 x 1/2"	192	1,3	6000
		47,6	19,8	15,1	2,8	13,9	4,7	20,2			422	79	4425
LDG-15X-120Y-FC2-3	LDG-15X-120Y-FO2-3	1214	508	384	71	352	120	518	2 x 1/2"	2 x 1/2"	194	1,5	6000
		47,8	20,0	15,1	2,8	13,9	4,7	20,4			428	92	4425
LDG-15X-070Y-FC3-1	LDG-15X-070Y-FO3-1	1176	470	384	71	352	120	480	2 x 1/2"	2 x 1/2"	166	0,5	6000
		46,3	18,5	15,1	2,8	13,9	4,7	18,9			365	31	4425
LDG-15X-080Y-FC3-1	LDG-15X-080Y-FO3-1	1176	470	384	71	352	120	480	2 x 1/2"	2 x 1/2"	168	0,7	6000
		46,3	18,5	15,1	2,8	13,9	4,7	18,9			370	43	4425
LDG-15X-090Y-FC3-1	LDG-15X-090Y-FO3-1	1176	470	384	71	352	120	480	2 x 1/2"	2 x 1/2"	173	0,9	6000
		46,3	18,5	15,1	2,8	13,9	4,7	18,9			380	55	4425
LDG-15X-100Y-FC3-1	LDG-15X-100Y-FO3-1	1176	470	384	71	352	120	480	2 x 1/2"	2 x 1/2"	175	1,1	6000
		46,3	18,5	15,1	2,8	13,9	4,7	18,9			386	67	4425
LDG-15X-110Y-FC3-1	LDG-15X-110Y-FO3-1	1209	503	384	71	352	120	513	2 x 1/2"	2 x 1/2"	178	1,3	6000
		47,6	19,8	15,1	2,8	13,9	4,7	20,2			391	79	4425
LDG-15X-120Y-FC3-1	LDG-15X-120Y-FO3-1	1214	508	384	71	352	120	518	2 x 1/2"	2 x 1/2"	180	1,5	6000
		47,8	20,0	15,1	2,8	13,9	4,7	20,4			397	92	4425
LDG-15X-080Y-FC3-2	LDG-15X-080Y-FO3-2	1176	470	384	71	352	120	480	2 x 1/2"	2 x 1/2"	182	0,7	6000
		46,3	18,5	15,1	2,8	13,9	4,7	18,9			401	43	4425
LDG-15X-090Y-FC3-2	LDG-15X-090Y-FO3-2	1176	470	384	71	352	120	480	2 x 1/2"	2 x 1/2"	187	0,9	6000
		46,3	18,5	15,1	2,8	13,9	4,7	18,9			411	55	4425
LDG-15X-100Y-FC3-2													



Limitorque™ LDG Direct Gas Heavy-Duty Actuator Series FCD LFENTB0005-00-AQ - 06/16

LDG Single Acting - Dimensions: mm (in) - Weights: Kg (lbs) - Swept Volumes: l (cu in) - MOT: Nm (ft-lb)													
Model	a	b	c	d	e	f	g	P ¹ NPT PORT	N ¹ NPT PORT	Weight	Swept Volume*	MOT	
LDG-20X-070Y-FC1-1	LDG-20X-070Y-FO1-1	1471	579	305	27	444	150	582	2 x 1/2"	2 x 1/2"	214	0.7	12000
		57.9	22.8	12.0	1.1	17.5	5.9	22.9			473	43	8851
LDG-20X-080Y-FC1-1	LDG-20X-080Y-FO1-1	1471	579	305	27	444	150	582	2 x 1/2"	2 x 1/2"	217	0.9	12000
		57.9	22.8	12.0	1.1	17.5	5.9	22.9			478	55	8851
LDG-20X-090Y-FC1-1	LDG-20X-090Y-FO1-1	1471	579	305	27	444	150	582	2 x 1/2"	2 x 1/2"	222	1.1	12000
		57.9	22.8	12.0	1.1	17.5	5.9	22.9			489	67	8851
LDG-20X-100Y-FC1-1	LDG-20X-100Y-FO1-1	1471	579	305	27	444	150	582	2 x 1/2"	2 x 1/2"	224	1.4	12000
		57.9	22.8	12.0	1.1	17.5	5.9	22.9			495	85	8851
LDG-20X-110Y-FC1-1	LDG-20X-110Y-FO1-1	1471	579	305	27	444	150	582	2 x 1/2"	2 x 1/2"	227	1.7	12000
		57.9	22.8	12.0	1.1	17.5	5.9	22.9			500	104	8851
LDG-20X-120Y-FC1-1	LDG-20X-120Y-FO1-1	1519	627	305	27	444	150	630	2 x 1/2"	2 x 1/2"	230	2.0	12000
		59.8	24.7	12.0	1.1	17.5	5.9	24.8			506	122	8851
LDG-20X-140Y-FC1-1	LDG-20X-140Y-FO1-1	1519	627	305	27	444	150	630	2 x 1/2"	2 x 1/2"	235	2.7	12000
		59.8	24.7	12.0	1.1	17.5	5.9	24.8			518	165	8851
LDG-20X-070Y-FC2-1	LDG-20X-070Y-FO2-1	1471	579	384	59	444	150	582	2 x 1/2"	2 x 1/2"	228	0.7	12000
		57.9	22.8	15.1	2.3	17.5	5.9	22.9			503	43	8851
LDG-20X-080Y-FC2-1	LDG-20X-080Y-FO2-1	1471	579	384	59	444	150	582	2 x 1/2"	2 x 1/2"	231	0.9	12000
		57.9	22.8	15.1	2.3	17.5	5.9	22.9			509	55	8851
LDG-20X-090Y-FC2-1	LDG-20X-090Y-FO2-1	1471	579	384	59	444	150	582	2 x 1/2"	2 x 1/2"	236	1.1	12000
		57.9	22.8	15.1	2.3	17.5	5.9	22.9			520	67	8851
LDG-20X-100Y-FC2-1	LDG-20X-100Y-FO2-1	1471	579	384	59	444	150	582	2 x 1/2"	2 x 1/2"	238	1.4	12000
		57.9	22.8	15.1	2.3	17.5	5.9	22.9			525	85	8851
LDG-20X-110Y-FC2-1	LDG-20X-110Y-FO2-1	1471	579	384	59	444	150	582	2 x 1/2"	2 x 1/2"	241	1.7	12000
		57.9	22.8	15.1	2.3	17.5	5.9	22.9			531	104	8851
LDG-20X-120Y-FC2-1	LDG-20X-120Y-FO2-1	1519	627	384	59	444	150	630	2 x 1/2"	2 x 1/2"	244	2.0	12000
		59.8	24.7	15.1	2.3	17.5	5.9	24.8			537	122	8851
LDG-20X-140Y-FC2-1	LDG-20X-140Y-FO2-1	1519	627	384	59	444	150	630	2 x 1/2"	2 x 1/2"	249	2.7	12000
		59.8	24.7	15.1	2.3	17.5	5.9	24.8			549	165	8851
LDG-20X-080Y-FC2-2	LDG-20X-080Y-FO2-2	1471	579	384	59	444	150	582	2 x 1/2"	2 x 1/2"	234	0.9	12000
		57.9	22.8	15.1	2.3	17.5	5.9	22.9			516	55	8851
LDG-20X-090Y-FC2-2	LDG-20X-090Y-FO2-2	1471	579	384	59	444	150	582	2 x 1/2"	2 x 1/2"	239	1.1	12000
		57.9	22.8	15.1	2.3	17.5	5.9	22.9			526	67	8851
LDG-20X-100Y-FC2-2	LDG-20X-100Y-FO2-2	1471	579	384	59	444	150	582	2 x 1/2"	2 x 1/2"	241	1.4	12000
		57.9	22.8	15.1	2.3	17.5	5.9	22.9			532	85	8851
LDG-20X-110Y-FC2-2	LDG-20X-110Y-FO2-2	1471	579	384	59	444	150	582	2 x 1/2"	2 x 1/2"	244	1.7	12000
		57.9	22.8	15.1	2.3	17.5	5.9	22.9			538	104	8851
LDG-20X-120Y-FC2-2	LDG-20X-120Y-FO2-2	1519	627	384	59	444	150	630	2 x 1/2"	2 x 1/2"	247	2.0	12000
		59.8	24.7	15.1	2.3	17.5	5.9	24.8			544	122	8851
LDG-20X-140Y-FC2-2	LDG-20X-140Y-FO2-2	1519	627	384	59	444	150	630	2 x 1/2"	2 x 1/2"	252	2.7	12000
		59.8	24.7	15.1	2.3	17.5	5.9	24.8			556	165	8851
LDG-20X-090Y-FC2-3	LDG-20X-090Y-FO2-3	1471	579	384	59	444	150	582	2 x 1/2"	2 x 1/2"	254	1.1	12000
		57.9	22.8	15.1	2.3	17.5	5.9	22.9			559	67	8851
LDG-20X-100Y-FC2-3	LDG-20X-100Y-FO2-3	1471	579	384	59	444	150	582	2 x 1/2"	2 x 1/2"	256	1.4	12000
		57.9	22.8	15.1	2.3	17.5	5.9	22.9			565	85	8851
LDG-20X-110Y-FC2-3	LDG-20X-110Y-FO2-3	1471	579	384	59	444	150	582	2 x 1/2"	2 x 1/2"	259	1.7	12000
		57.9	22.8	15.1	2.3	17.5	5.9	22.9			571	104	8851
LDG-20X-120Y-FC2-3	LDG-20X-120Y-FO2-3	1519	627	384	59	444	150	630	2 x 1/2"	2 x 1/2"	262	2.0	12000
		59.8	24.7	15.1	2.3	17.5	5.9	24.8			577	122	8851
LDG-20X-140Y-FC2-3	LDG-20X-140Y-FO2-3	1519	627	384	59	444	150	630	2 x 1/2"	2 x 1/2"	267	2.7	12000
		59.8	24.7	15.1	2.3	17.5	5.9	24.8			589	165	8851
LDG-20X-090Y-FC3-1	LDG-20X-090Y-FO3-1	1481	579	442	88	444	150	582	2 x 1/2"	2 x 1/2"	286	1.1	12000
		58.3	22.8	17.4	3.4	17.5	5.9	22.9			630	67	8851
LDG-20X-100Y-FC3-1	LDG-20X-100Y-FO3-1	1481	579	442	88	444	150	582	2 x 1/2"	2 x 1/2"	288	1.4	12000
		58.3	22.8	17.4	3.4	17.5	5.9	22.9			636	85	8851
LDG-20X-110Y-FC3-1	LDG-20X-110Y-FO3-1	1481	579	442	88	444	150	582	2 x 1/2"	2 x 1/2"	291	1.7	12000
		58.3	22.8	17.4	3.4	17.5	5.9	22.9			642	104	8851
LDG-20X-120Y-FC3-1	LDG-20X-120Y-FO3-1	1529	627	442	88	444	150	630	2 x 1/2"	2 x 1/2"	294	2.0	12000
		60.2	24.7	17.4	3.4	17.5	5.9	24.8			647	122	8851
LDG-20X-140Y-FC3-1	LDG-20X-140Y-FO3-1	1529	627	442	88	444	150	630	2 x 1/2"	2 x 1/2"	299	2.7	12000
		60.2	24.7	17.4	3.4	17.5	5.9	24.8			659	165	8851
LDG-20X-100Y-FC3-2	LDG-20X-100Y-FO3-2	1481	579	442	88	444	150	582	2 x 1/2"	2 x 1/2"	305	1.4	12000
		58.3	22.8	17.4	3.4	17.5	5.9	22.9			673	85	8851
LDG-20X-110Y-FC3-2	LDG-20X-110Y-FO3-2	1481	579	442	88	444	150	582	2 x 1/2"	2 x 1/2"	308	1.7	12000
		58.3	22.8	17.4	3.4	17.5	5.9	22.9			679	104	8851
LDG-20X-120Y-FC3-2	LDG-20X-120Y-FO3-2	1529	627	442	88	444	150	630	2 x 1/2"	2 x 1/2"	311	2.0	12000
		60.2	24.7	17.4	3.4	17.5	5.9	24.8			685	122	8851
LDG-20X-140Y-FC3-2	LDG-20X-140Y-FO3-2	1529	627	442	88	444	150	630	2 x 1/2"	2 x 1/2"	316	2.7	12000
		60.2	24.7	17.4	3.4	17.5	5.9	24.8			697	165	8851
LDG-20X-110Y-FC3-3	LDG-20X-110Y-FO3-3	1481	579	442	88	444	150	582	2 x 1/2"	2 x 1/2"	313	1.7	12000
		58.3	22.8	17.4	3.4	17.5	5.9	22.9			690	104	8851
LDG-20X-120Y-FC3-3	LDG-20X-120Y-FO3-3	1529	627	442	88	444	150	630	2 x 1/2"	2 x 1/2"	316	2.0	12000
		60.2	24.7	17.4	3.4	17.5	5.9	24.8			696	122	8851
LDG-20X-140Y-FC3-3	LDG-20X-140Y-FO3-3	1529	627	442	88	444	150	630	2 x 1/2"	2 x 1/2"	321	2.7	12000
		60.2	24.7	17.4	3.4	17.5	5.9	24.8			708	165	8851
LDG-20X-100Y-FC4-1	LDG-20X-100Y-FO4-1	1584	579	506	120	458	150	582	2 x 1/2"	2 x 1/2"	392	1.4	12000
		62.3	22.8	19.9	4.7	18.0	5.9	22.9			865	85	8851
LDG-20X-110Y-FC4-1	LDG-20X-110Y-FO4-1	1584	579	506	120	458	150	582	2 x 1/2"	2 x 1/2"	395	1.7	12000
		62.3	22.8	19.9	4.7	18.0	5.9	22.9			871	104	8851
LDG-20X-120Y-FC4-1	LDG-20X-120Y-FO4-1	1632	627	506	120	458	150	630	2 x 1/2"	2 x 1/2"	398	2.0	12000
		64.2	24.7	19.9	4.7	18.0	5.9	24.8			877	122	8851
LDG-20X-140Y-FC4-1	LDG-20X-140Y-FO4-1	1632	627	506	120	458	150	630	2 x 1/2"	2 x 1/2"	403	2.7	12000
		64.2	24.7	19.9	4.7	18.0	5.9	24.8			888	165	8851
LDG-20X-110Y-FC4-2	LDG-20X-110Y-FO4-2	1584	579	506	120	458	150	582	2 x 1/2"	2 x 1/2"	395	1.7	12000
		62.3	22.8	19.9	4.7	18.0	5.9	22.9			871	104	8851
LDG-20X-120Y-FC4-2	LDG-20X-120Y-FO4-2	1632											



Limitorque™ LDG Direct Gas Heavy-Duty Actuator Series FCD LFENTB0005-00-AQ - 06/16

LDG Single Acting - Dimensions: mm (in) - Weights: Kg (lbs) - Swept Volumes: l (cu in) - MOT: Nm (ft-lb)													
Model	a	b	c	d	e	f	g	"P" NPT PORT	"N" NPT PORT	Weight	Swept Volume*	MOT	
LDG-25X-180Y-FC1-1	LDG-25X-180Y-FO1-1	1774	742	384	44	534	188	760	2 x 3/4"	2 x 3/4"	343	5,6	21000
		69,8	29,2	15,1	1,7	21,0	7,4	29,9			755	342	15489
LDG-25X-080Y-FC1-2	LDG-25X-080Y-FO1-2	1713	681	384	44	534	188	699	2 x 1/2"	2 x 1/2"	308	1,1	21000
		67,4	26,8	15,1	1,7	21,0	7,4	27,5			679	67	15489
LDG-25X-090Y-FC1-2	LDG-25X-090Y-FO1-2	1713	681	384	44	534	188	699	2 x 1/2"	2 x 1/2"	314	1,4	21000
		67,4	26,8	15,1	1,7	21,0	7,4	27,5			693	85	15489
LDG-25X-100Y-FC1-2	LDG-25X-100Y-FO1-2	1713	681	384	44	534	188	699	2 x 1/2"	2 x 1/2"	318	1,7	21000
		67,4	26,8	15,1	1,7	21,0	7,4	27,5			702	104	15489
LDG-25X-110Y-FC1-2	LDG-25X-110Y-FO1-2	1713	681	384	44	534	188	699	2 x 1/2"	2 x 1/2"	323	2,1	21000
		67,4	26,8	15,1	1,7	21,0	7,4	27,5			711	128	15489
LDG-25X-120Y-FC1-2	LDG-25X-120Y-FO1-2	1718	686	384	44	534	188	704	2 x 1/2"	2 x 1/2"	327	2,5	21000
		67,6	27,0	15,1	1,7	21,0	7,4	27,7			720	153	15489
LDG-25X-140Y-FC1-2	LDG-25X-140Y-FO1-2	1718	686	384	44	534	188	704	2 x 1/2"	2 x 1/2"	335	3,4	21000
		67,6	27,0	15,1	1,7	21,0	7,4	27,7			739	207	15489
LDG-25X-160Y-FC1-2	LDG-25X-160Y-FO1-2	1769	737	384	44	534	188	755	2 x 1/2"	2 x 1/2"	343	4,4	21000
		69,6	29,0	15,1	1,7	21,0	7,4	29,7			757	269	15489
LDG-25X-180Y-FC1-2	LDG-25X-180Y-FO1-2	1774	742	384	44	534	188	760	2 x 3/4"	2 x 3/4"	352	5,6	21000
		69,8	29,2	15,1	1,7	21,0	7,4	29,9			775	342	15489
LDG-25X-090Y-FC1-3	LDG-25X-090Y-FO1-3	1713	681	384	44	534	188	699	2 x 1/2"	2 x 1/2"	328	1,4	21000
		67,4	26,8	15,1	1,7	21,0	7,4	27,5			723	85	15489
LDG-25X-100Y-FC1-3	LDG-25X-100Y-FO1-3	1713	681	384	44	534	188	699	2 x 1/2"	2 x 1/2"	332	1,7	21000
		67,4	26,8	15,1	1,7	21,0	7,4	27,5			733	104	15489
LDG-25X-110Y-FC1-3	LDG-25X-110Y-FO1-3	1713	681	384	44	534	188	699	2 x 1/2"	2 x 1/2"	337	2,1	21000
		67,4	26,8	15,1	1,7	21,0	7,4	27,5			742	128	15489
LDG-25X-120Y-FC1-3	LDG-25X-120Y-FO1-3	1718	686	384	44	534	188	704	2 x 1/2"	2 x 1/2"	341	2,5	21000
		67,6	27,0	15,1	1,7	21,0	7,4	27,7			751	153	15489
LDG-25X-140Y-FC1-3	LDG-25X-140Y-FO1-3	1718	686	384	44	534	188	704	2 x 1/2"	2 x 1/2"	349	3,4	21000
		67,6	27,0	15,1	1,7	21,0	7,4	27,7			769	207	15489
LDG-25X-160Y-FC1-3	LDG-25X-160Y-FO1-3	1769	737	384	44	534	188	755	2 x 1/2"	2 x 1/2"	357	4,4	21000
		69,6	29,0	15,1	1,7	21,0	7,4	29,7			788	269	15489
LDG-25X-180Y-FC1-3	LDG-25X-180Y-FO1-3	1774	742	384	44	534	188	760	2 x 3/4"	2 x 3/4"	366	5,6	21000
		69,8	29,2	15,1	1,7	21,0	7,4	29,9			806	342	15489
LDG-25X-100Y-FC2-1	LDG-25X-100Y-FO2-1	1713	681	442	73	534	188	699	2 x 1/2"	2 x 1/2"	368	1,7	21000
		67,4	26,8	17,4	2,9	21,0	7,4	27,5			812	104	15489
LDG-25X-110Y-FC2-1	LDG-25X-110Y-FO2-1	1713	681	442	73	534	188	699	2 x 1/2"	2 x 1/2"	373	2,1	21000
		67,4	26,8	17,4	2,9	21,0	7,4	27,5			821	128	15489
LDG-25X-120Y-FC2-1	LDG-25X-120Y-FO2-1	1718	686	442	73	534	188	704	2 x 1/2"	2 x 1/2"	377	2,5	21000
		67,6	27,0	17,4	2,9	21,0	7,4	27,7			830	153	15489
LDG-25X-140Y-FC2-1	LDG-25X-140Y-FO2-1	1718	686	442	73	534	188	704	2 x 1/2"	2 x 1/2"	385	3,4	21000
		67,6	27,0	17,4	2,9	21,0	7,4	27,7			849	207	15489
LDG-25X-160Y-FC2-1	LDG-25X-160Y-FO2-1	1769	737	442	73	534	188	755	2 x 1/2"	2 x 1/2"	393	4,4	21000
		69,6	29,0	17,4	2,9	21,0	7,4	29,7			867	269	15489
LDG-25X-180Y-FC2-1	LDG-25X-180Y-FO2-1	1774	742	442	73	534	188	760	2 x 3/4"	2 x 3/4"	402	5,6	21000
		69,8	29,2	17,4	2,9	21,0	7,4	29,9			886	342	15489
LDG-25X-100Y-FC2-2	LDG-25X-100Y-FO2-2	1713	681	442	73	534	188	699	2 x 1/2"	2 x 1/2"	385	1,7	21000
		67,4	26,8	17,4	2,9	21,0	7,4	27,5			850	104	15489
LDG-25X-110Y-FC2-2	LDG-25X-110Y-FO2-2	1713	681	442	73	534	188	699	2 x 1/2"	2 x 1/2"	390	2,1	21000
		67,4	26,8	17,4	2,9	21,0	7,4	27,5			859	128	15489
LDG-25X-120Y-FC2-2	LDG-25X-120Y-FO2-2	1718	686	442	73	534	188	704	2 x 1/2"	2 x 1/2"	394	2,5	21000
		67,6	27,0	17,4	2,9	21,0	7,4	27,7			868	153	15489
LDG-25X-140Y-FC2-2	LDG-25X-140Y-FO2-2	1718	686	442	73	534	188	704	2 x 1/2"	2 x 1/2"	402	3,4	21000
		67,6	27,0	17,4	2,9	21,0	7,4	27,7			886	207	15489
LDG-25X-160Y-FC2-2	LDG-25X-160Y-FO2-2	1769	737	442	73	534	188	755	2 x 1/2"	2 x 1/2"	410	4,4	21000
		69,6	29,0	17,4	2,9	21,0	7,4	29,7			905	269	15489
LDG-25X-180Y-FC2-2	LDG-25X-180Y-FO2-2	1774	742	442	73	534	188	760	2 x 3/4"	2 x 3/4"	419	5,6	21000
		69,8	29,2	17,4	2,9	21,0	7,4	29,9			923	342	15489
LDG-25X-110Y-FC2-3	LDG-25X-110Y-FO2-3	1713	681	442	73	534	188	699	2 x 1/2"	2 x 1/2"	395	2,1	21000
		67,4	26,8	17,4	2,9	21,0	7,4	27,5			870	128	15489
LDG-25X-120Y-FC2-3	LDG-25X-120Y-FO2-3	1718	686	442	73	534	188	704	2 x 1/2"	2 x 1/2"	399	2,5	21000
		67,6	27,0	17,4	2,9	21,0	7,4	27,7			879	153	15489
LDG-25X-140Y-FC2-3	LDG-25X-140Y-FO2-3	1718	686	442	73	534	188	704	2 x 1/2"	2 x 1/2"	407	3,4	21000
		67,6	27,0	17,4	2,9	21,0	7,4	27,7			897	207	15489
LDG-25X-160Y-FC2-3	LDG-25X-160Y-FO2-3	1769	737	442	73	534	188	755	2 x 1/2"	2 x 1/2"	415	4,4	21000
		69,6	29,0	17,4	2,9	21,0	7,4	29,7			916	269	15489
LDG-25X-180Y-FC2-3	LDG-25X-180Y-FO2-3	1774	742	442	73	534	188	760	2 x 3/4"	2 x 3/4"	424	5,6	21000
		69,8	29,2	17,4	2,9	21,0	7,4	29,9			934	342	15489
LDG-25X-080Y-FC3-1	LDG-25X-080Y-FO3-1	1752	681	442	73	534	188	699	2 x 1/2"	2 x 1/2"	357	1,1	21000
		69,0	26,8	17,4	2,9	21,0	7,4	27,5			787	67	15489
LDG-25X-090Y-FC3-1	LDG-25X-090Y-FO3-1	1752	681	442	73	534	188	699	2 x 1/2"	2 x 1/2"	363	1,4	21000
		69,0	26,8	17,4	2,9	21,0	7,4	27,5			801	85	15489
LDG-25X-100Y-FC3-1	LDG-25X-100Y-FO3-1	1752	681	442	73	534	188	699	2 x 1/2"	2 x 1/2"	367	1,7	21000
		69,0	26,8	17,4	2,9	21,0	7,4	27,5			810	104	15489
LDG-25X-110Y-FC3-1	LDG-25X-110Y-FO3-1	1752	681	442	73	534	188	699	2 x 1/2"	2 x 1/2"	372	2,1	21000
		69,0	26,8	17,4	2,9	21,0	7,4	27,5			819	128	15489
LDG-25X-120Y-FC3-1	LDG-25X-120Y-FO3-1	1757	686	442	73	534	188	704	2 x 1/2"	2 x 1/2"	376	2,5	21000
		69,2	27,0	17,4	2,9	21,0	7,4	27,7			828	153	15489
LDG-25X-140Y-FC3-1	LDG-25X-140Y-FO3-1	1757	686	442	73	534	188	704	2 x 1/2"	2 x 1/2"	384	3,4	21000
		69,2	27,0	17,4	2,9	21,0	7,4	27,7			847	207	15489
LDG-25X-160Y-FC3-1	LDG-25X-160Y-FO3-1	1808	737	442	73	534	188	755	2 x 1/2"	2 x 1/2"	392	4,4	21000
		71,2	29,0	17,4	2,9	21,0	7,4	29,7			865	269	15489
LDG-25X-180Y-FC3-1	LDG-25X-180Y-FO3-1	1813	742	442	73	534	188	760	2 x 3/4"	2 x 3/4"	401	5,6	21000
		71,4	29,2	17,4	2,9	21,0	7,4	29,9			883	342	15489
LDG-25X-090Y-FC3-2	LDG-25X-090Y-FO3-2	1752	681	442	73	534	188	699	2 x 1/2"	2 x 1/2"	385	1,4	21000
		69,0	26,8	17,4	2,9	21,0	7,4	27,5			849	85	15489
LDG-25X-100Y-FC3-2	LDG-25X-100Y-FO3-2	1752	681	442	73	534	188	699	2 x 1/2"	2 x 1/2"	389	1,7	21000
		69,0	26,8	17,4	2,9	21,0	7,4	27,5			858	104	15489
LDG-25X-110Y-FC3-2	LDG-25X-110Y-FO3-2	1752	681	442	73	534	188	699	2 x 1/2"	2 x 1/2"	394	2,1	21000
		69,0	26,8	17,4	2,9	21,0	7,4	27,5			868	128	15489
LDG-25X-120Y-FC3-2	LDG-25X-120Y-FO3-2	1757	686	442	73	534	188	704	2 x 1/2"	2 x 1/2"	398	2,5	21000
		69,2	27,0	17,4	2,9	21,0	7,4	27,7			877	153	15489
LDG-25X-140Y-FC3-2	LDG-25X-140Y-FO3-2	1757	686	442	73	534	188	704	2 x 1/2"	2 x 1/2"	406	3,4	



Limitorque™ LDG Direct Gas Heavy-Duty Actuator Series FCD LFENTB0005-00-AQ - 06/16

LDG Single Acting - Dimensions: mm (in) - Weights: Kg (lbs) - Swept Volumes: l (cu in) - MOT: Nm (ft-lb)													
Model		a	b	c	d	e	f	g	"P" NPT PORT	"N" NPT PORT	Weight	Swept Volume*	MOT
LDG-25X-160Y-FC3-3	LDG-25X-160Y-FO3-3	1808	737	442	73	534	188	755	2 x 1/2"	2 x 1/2"	437	4,4	21000
		71,2	29,0	17,4	2,9	21,0	7,4	29,7			964	269	15489
LDG-25X-180Y-FC3-3	LDG-25X-180Y-FO3-3	1813	742	442	73	534	188	760	2 x 3/4"	2 x 3/4"	446	5,6	21000
		71,4	29,2	17,4	2,9	21,0	7,4	29,9			983	342	15489
LDG-25X-110Y-FC3-4	LDG-25X-110Y-FO3-4	1752	681	442	73	534	188	699	2 x 1/2"	2 x 1/2"	427	2,1	21000
		69,0	26,8	17,4	2,9	21,0	7,4	27,5			940	128	15489
LDG-25X-120Y-FC3-4	LDG-25X-120Y-FO3-4	1757	686	442	73	534	188	704	2 x 1/2"	2 x 1/2"	431	2,5	21000
		69,2	27,0	17,4	2,9	21,0	7,4	27,7			949	153	15489
LDG-25X-140Y-FC3-4	LDG-25X-140Y-FO3-4	1757	686	442	73	534	188	704	2 x 1/2"	2 x 1/2"	439	3,4	21000
		69,2	27,0	17,4	2,9	21,0	7,4	27,7			968	207	15489
LDG-25X-160Y-FC3-4	LDG-25X-160Y-FO3-4	1808	737	442	73	534	188	755	2 x 1/2"	2 x 1/2"	447	4,4	21000
		71,2	29,0	17,4	2,9	21,0	7,4	29,7			986	269	15489
LDG-25X-180Y-FC3-4	LDG-25X-180Y-FO3-4	1813	742	442	73	534	188	760	2 x 3/4"	2 x 3/4"	456	5,6	21000
		71,4	29,2	17,4	2,9	21,0	7,4	29,9			1005	342	15489
LDG-25X-110Y-FC4-1	LDG-25X-110Y-FO4-1	1782	681	480	92	534	188	699	2 x 1/2"	2 x 1/2"	443	2,1	21000
		70,2	26,8	18,9	3,6	21,0	7,4	27,5			976	128	15489
LDG-25X-120Y-FC4-1	LDG-25X-120Y-FO4-1	1787	686	480	92	534	188	704	2 x 1/2"	2 x 1/2"	447	2,5	21000
		70,4	27,0	18,9	3,6	21,0	7,4	27,7			985	153	15489
LDG-25X-140Y-FC4-1	LDG-25X-140Y-FO4-1	1787	686	480	92	534	188	704	2 x 1/2"	2 x 1/2"	455	3,4	21000
		70,4	27,0	18,9	3,6	21,0	7,4	27,7			1003	207	15489
LDG-25X-160Y-FC4-1	LDG-25X-160Y-FO4-1	1838	737	480	92	534	188	755	2 x 1/2"	2 x 1/2"	463	4,4	21000
		72,4	29,0	18,9	3,6	21,0	7,4	29,7			1021	269	15489
LDG-25X-180Y-FC4-1	LDG-25X-180Y-FO4-1	1843	742	480	92	534	188	760	2 x 3/4"	2 x 3/4"	472	5,6	21000
		72,6	29,2	18,9	3,6	21,0	7,4	29,9			1040	342	15489
LDG-25X-120Y-FC4-2	LDG-25X-120Y-FO4-2	1787	686	480	92	534	188	704	2 x 1/2"	2 x 1/2"	473	2,5	21000
		70,4	27,0	18,9	3,6	21,0	7,4	27,7			1042	153	15489
LDG-25X-140Y-FC4-2	LDG-25X-140Y-FO4-2	1787	686	480	92	534	188	704	2 x 1/2"	2 x 1/2"	481	3,4	21000
		70,4	27,0	18,9	3,6	21,0	7,4	27,7			1060	207	15489
LDG-25X-160Y-FC4-2	LDG-25X-160Y-FO4-2	1838	737	480	92	534	188	755	2 x 1/2"	2 x 1/2"	489	4,4	21000
		72,4	29,0	18,9	3,6	21,0	7,4	29,7			1079	269	15489
LDG-25X-180Y-FC4-2	LDG-25X-180Y-FO4-2	1843	742	480	92	534	188	760	2 x 3/4"	2 x 3/4"	498	5,6	21000
		72,6	29,2	18,9	3,6	21,0	7,4	29,9			1097	342	15489
LDG-25X-120Y-FC4-3	LDG-25X-120Y-FO4-3	1787	686	480	92	534	188	704	2 x 1/2"	2 x 1/2"	486	2,5	21000
		70,4	27,0	18,9	3,6	21,0	7,4	27,7			1071	153	15489
LDG-25X-140Y-FC4-3	LDG-25X-140Y-FO4-3	1787	686	480	92	534	188	704	2 x 1/2"	2 x 1/2"	494	3,4	21000
		70,4	27,0	18,9	3,6	21,0	7,4	27,7			1089	207	15489
LDG-25X-160Y-FC4-3	LDG-25X-160Y-FO4-3	1838	737	480	92	534	188	755	2 x 1/2"	2 x 1/2"	502	4,4	21000
		72,4	29,0	18,9	3,6	21,0	7,4	29,7			1107	269	15489
LDG-25X-180Y-FC4-3	LDG-25X-180Y-FO4-3	1843	742	480	92	534	188	760	2 x 3/4"	2 x 3/4"	511	5,6	21000
		72,6	29,2	18,9	3,6	21,0	7,4	29,9			1126	342	15489
LDG-25X-140Y-FC5-1	LDG-25X-140Y-FO5-1	1841	686	485	137	548	188	704	2 x 1/2"	2 x 1/2"	597	3,4	21000
		72,5	27,0	19,1	5,4	21,6	7,4	27,7			1316	207	15489
LDG-25X-160Y-FC5-1	LDG-25X-160Y-FO5-1	1892	737	485	137	548	188	755	2 x 1/2"	2 x 1/2"	605	4,4	21000
		74,5	29,0	19,1	5,4	21,6	7,4	29,7			1335	269	15489
LDG-25X-180Y-FC5-1	LDG-25X-180Y-FO5-1	1897	742	485	137	548	188	760	2 x 3/4"	2 x 3/4"	614	5,6	21000
		74,7	29,2	19,1	5,4	21,6	7,4	29,9			1353	342	15489
LDG-25X-070Y-FC5-2	LDG-25X-070Y-FO5-2	1836	681	485	137	548	188	699	2 x 1/2"	2 x 1/2"	576	0,8	21000
		72,3	26,8	19,1	5,4	21,6	7,4	27,5			1269	49	15489
LDG-25X-140Y-FC5-2	LDG-25X-140Y-FO5-2	1841	686	485	137	548	188	704	2 x 1/2"	2 x 1/2"	607	3,4	21000
		72,5	27,0	19,1	5,4	21,6	7,4	27,7			1338	207	15489
LDG-25X-160Y-FC5-2	LDG-25X-160Y-FO5-2	1892	737	485	137	548	188	755	2 x 1/2"	2 x 1/2"	615	4,4	21000
		74,5	29,0	19,1	5,4	21,6	7,4	29,7			1357	269	15489
LDG-25X-180Y-FC5-2	LDG-25X-180Y-FO5-2	1897	742	485	137	548	188	760	2 x 3/4"	2 x 3/4"	624	5,6	21000
		74,7	29,2	19,1	5,4	21,6	7,4	29,9			1375	342	15489
LDG-30X-100Y-FC1-1	LDG-30X-100Y-FO1-1	2115	837	446	42	670	215	857	2 x 1/2"	2 x 1/2"	581	2,2	40500
		83,3	33,0	17,6	1,7	26,4	8,5	33,7			1281	134	29871
LDG-30X-110Y-FC1-1	LDG-30X-110Y-FO1-1	2120	842	446	42	670	215	862	2 x 1/2"	2 x 1/2"	587	2,7	40500
		83,5	33,1	17,6	1,7	26,4	8,5	33,9			1294	165	29871
LDG-30X-120Y-FC1-1	LDG-30X-120Y-FO1-1	2125	847	446	42	670	215	867	2 x 1/2"	2 x 1/2"	593	3,2	40500
		83,7	33,3	17,6	1,7	26,4	8,5	34,1			1307	195	29871
LDG-30X-140Y-FC1-1	LDG-30X-140Y-FO1-1	2130	852	446	42	670	215	872	2 x 1/2"	2 x 1/2"	605	4,4	40500
		83,9	33,5	17,6	1,7	26,4	8,5	34,3			1334	269	29871
LDG-30X-160Y-FC1-1	LDG-30X-160Y-FO1-1	2135	857	446	42	670	215	877	2 x 1/2"	2 x 1/2"	617	5,7	40500
		84,1	33,7	17,6	1,7	26,4	8,5	34,5			1360	348	29871
LDG-30X-180Y-FC1-1	LDG-30X-180Y-FO1-1	2140	862	446	42	670	215	882	2 x 3/4"	2 x 3/4"	629	7,2	40500
		84,2	33,9	17,6	1,7	26,4	8,5	34,7			1387	439	29871
LDG-30X-200Y-FC1-1	LDG-30X-200Y-FO1-1	2214	936	446	42	670	215	956	2 x 3/4"	2 x 3/4"	645	8,9	40500
		87,1	36,8	17,6	1,7	26,4	8,5	37,6			1422	543	29871
LDG-30X-220Y-FC1-1	LDG-30X-220Y-FO1-1	2224	946	446	42	670	215	966	2 x 3/4"	2 x 3/4"	657	10,8	40500
		87,6	37,2	17,6	1,7	26,4	8,5	38,0			1448	659	29871
LDG-30X-110Y-FC1-2	LDG-30X-110Y-FO1-2	2123	842	446	42	670	215	862	2 x 1/2"	2 x 1/2"	611	2,7	40500
		83,6	33,1	17,6	1,7	26,4	8,5	33,9			1347	165	29871
LDG-30X-120Y-FC1-2	LDG-30X-120Y-FO1-2	2128	847	446	42	670	215	867	2 x 1/2"	2 x 1/2"	617	3,2	40500
		83,8	33,3	17,6	1,7	26,4	8,5	34,1			1360	195	29871
LDG-30X-140Y-FC1-2	LDG-30X-140Y-FO1-2	2133	852	446	42	670	215	872	2 x 1/2"	2 x 1/2"	629	4,4	40500
		84,0	33,5	17,6	1,7	26,4	8,5	34,3			1387	269	29871
LDG-30X-160Y-FC1-2	LDG-30X-160Y-FO1-2	2138	857	446	42	670	215	877	2 x 1/2"	2 x 1/2"	641	5,7	40500
		84,2	33,7	17,6	1,7	26,4	8,5	34,5			1413	348	29871
LDG-30X-180Y-FC1-2	LDG-30X-180Y-FO1-2	2143	862	446	42	670	215	882	2 x 3/4"	2 x 3/4"	653	7,2	40500
		84,4	33,9	17,6	1,7	26,4	8,5	34,7			1440	439	29871
LDG-30X-200Y-FC1-2	LDG-30X-200Y-FO1-2	2217	936	446	42	670	215	956	2 x 3/4"	2 x 3/4"	669	8,9	40500
		87,3	36,8	17,6	1,7	26,4	8,5	37,6			1475	543	29871
LDG-30X-220Y-FC1-2	LDG-30X-220Y-FO1-2	2227	946	446	42	670	215	966	2 x 3/4"	2 x 3/4"	681	10,8	40500
		87,7	37,2	17,6	1,7	26,4	8,5	38,0			1501	659	29871
LDG-30X-110Y-FC1-3	LDG-30X-110Y-FO1-3	2123	842	446	42	670	215	862	2 x 1/2"	2 x 1/2"			



Limitorque™ LDG Direct Gas Heavy-Duty Actuator Series FCD LFENTB0005-00-AQ - 06/16

LDG Single Acting - Dimensions: mm (in) - Weights: Kg (lbs) - Swept Volumes: l (cu in) - MOT: Nm (ft-lb)													
Model	a	b	c	d	e	f	g	"P" NPT PORT	"N" NPT PORT	Weight	Swept Volume*	MOT	
LDG-30X-160Y-FC2-1	LDG-30X-160Y-FO2-1	2138	857	480	57	670	215	877	2 x 1/2"	2 x 1/2"	666	5,7	40500
		84,2	33,7	18,9	2,2	26,4	8,5	34,5			1468	348	29871
LDG-30X-180Y-FC2-1	LDG-30X-180Y-FO2-1	2143	862	480	57	670	215	882	2 x 3/4"	2 x 3/4"	678	7,2	40500
		84,4	33,9	18,9	2,2	26,4	8,5	34,7			1495	439	29871
LDG-30X-200Y-FC2-1	LDG-30X-200Y-FO2-1	2217	936	480	57	670	215	956	2 x 3/4"	2 x 3/4"	694	8,9	40500
		87,3	36,8	18,9	2,2	26,4	8,5	37,6			1530	543	29871
LDG-30X-220Y-FC2-1	LDG-30X-220Y-FO2-1	2227	946	480	57	670	215	966	2 x 3/4"	2 x 3/4"	706	10,8	40500
		87,7	37,2	18,9	2,2	26,4	8,5	38,0			1556	659	29871
LDG-30X-120Y-FC2-2	LDG-30X-120Y-FO2-2	2128	847	480	57	670	215	867	2 x 1/2"	2 x 1/2"	669	3,2	40500
		83,8	33,3	18,9	2,2	26,4	8,5	34,1			1475	195	29871
LDG-30X-140Y-FC2-2	LDG-30X-140Y-FO2-2	2133	852	480	57	670	215	872	2 x 1/2"	2 x 1/2"	681	4,4	40500
		84,0	33,5	18,9	2,2	26,4	8,5	34,3			1501	269	29871
LDG-30X-160Y-FC2-2	LDG-30X-160Y-FO2-2	2138	857	480	57	670	215	877	2 x 1/2"	2 x 1/2"	693	5,7	40500
		84,2	33,7	18,9	2,2	26,4	8,5	34,5			1528	348	29871
LDG-30X-180Y-FC2-2	LDG-30X-180Y-FO2-2	2143	862	480	57	670	215	882	2 x 3/4"	2 x 3/4"	705	7,2	40500
		84,4	33,9	18,9	2,2	26,4	8,5	34,7			1554	439	29871
LDG-30X-200Y-FC2-2	LDG-30X-200Y-FO2-2	2217	936	480	57	670	215	956	2 x 3/4"	2 x 3/4"	721	8,9	40500
		87,3	36,8	18,9	2,2	26,4	8,5	37,6			1590	543	29871
LDG-30X-220Y-FC2-2	LDG-30X-220Y-FO2-2	2227	946	480	57	670	215	966	2 x 3/4"	2 x 3/4"	733	10,8	40500
		87,7	37,2	18,9	2,2	26,4	8,5	38,0			1616	659	29871
LDG-30X-140Y-FC2-3	LDG-30X-140Y-FO2-3	2133	852	480	57	670	215	872	2 x 1/2"	2 x 1/2"	694	4,4	40500
		84,0	33,5	18,9	2,2	26,4	8,5	34,3			1530	269	29871
LDG-30X-160Y-FC2-3	LDG-30X-160Y-FO2-3	2138	857	480	57	670	215	877	2 x 1/2"	2 x 1/2"	706	5,7	40500
		84,2	33,7	18,9	2,2	26,4	8,5	34,5			1556	348	29871
LDG-30X-180Y-FC2-3	LDG-30X-180Y-FO2-3	2143	862	480	57	670	215	882	2 x 3/4"	2 x 3/4"	718	7,2	40500
		84,4	33,9	18,9	2,2	26,4	8,5	34,7			1583	439	29871
LDG-30X-200Y-FC2-3	LDG-30X-200Y-FO2-3	2217	936	480	57	670	215	956	2 x 3/4"	2 x 3/4"	734	8,9	40500
		87,3	36,8	18,9	2,2	26,4	8,5	37,6			1618	543	29871
LDG-30X-220Y-FC2-3	LDG-30X-220Y-FO2-3	2227	946	480	57	670	215	966	2 x 3/4"	2 x 3/4"	746	10,8	40500
		87,7	37,2	18,9	2,2	26,4	8,5	38,0			1645	659	29871
LDG-30X-110Y-FC3-1	LDG-30X-110Y-FO3-1	2144	842	506	70	670	215	862	2 x 1/2"	2 x 1/2"	665	2,7	40500
		84,4	33,1	19,9	2,7	26,4	8,5	33,9			1466	165	29871
LDG-30X-120Y-FC3-1	LDG-30X-120Y-FO3-1	2149	847	506	70	670	215	867	2 x 1/2"	2 x 1/2"	671	3,2	40500
		84,6	33,3	19,9	2,7	26,4	8,5	34,1			1479	195	29871
LDG-30X-140Y-FC3-1	LDG-30X-140Y-FO3-1	2154	852	506	70	670	215	872	2 x 1/2"	2 x 1/2"	683	4,4	40500
		84,8	33,5	19,9	2,7	26,4	8,5	34,3			1506	269	29871
LDG-30X-160Y-FC3-1	LDG-30X-160Y-FO3-1	2159	857	506	70	670	215	877	2 x 1/2"	2 x 1/2"	695	5,7	40500
		85,0	33,7	19,9	2,7	26,4	8,5	34,5			1532	348	29871
LDG-30X-180Y-FC3-1	LDG-30X-180Y-FO3-1	2164	862	506	70	670	215	882	2 x 3/4"	2 x 3/4"	707	7,2	40500
		85,2	33,9	19,9	2,7	26,4	8,5	34,7			1559	439	29871
LDG-30X-200Y-FC3-1	LDG-30X-200Y-FO3-1	2238	936	506	70	670	215	956	2 x 3/4"	2 x 3/4"	723	8,9	40500
		88,1	36,8	19,9	2,7	26,4	8,5	37,6			1594	543	29871
LDG-30X-220Y-FC3-1	LDG-30X-220Y-FO3-1	2248	946	506	70	670	215	966	2 x 3/4"	2 x 3/4"	735	10,8	40500
		88,5	37,2	19,9	2,7	26,4	8,5	38,0			1620	659	29871
LDG-30X-120Y-FC3-2	LDG-30X-120Y-FO3-2	2149	847	506	70	670	215	867	2 x 1/2"	2 x 1/2"	701	3,2	40500
		84,6	33,3	19,9	2,7	26,4	8,5	34,1			1545	195	29871
LDG-30X-140Y-FC3-2	LDG-30X-140Y-FO3-2	2154	852	506	70	670	215	872	2 x 1/2"	2 x 1/2"	713	4,4	40500
		84,8	33,5	19,9	2,7	26,4	8,5	34,3			1572	269	29871
LDG-30X-160Y-FC3-2	LDG-30X-160Y-FO3-2	2159	857	506	70	670	215	877	2 x 1/2"	2 x 1/2"	725	5,7	40500
		85,0	33,7	19,9	2,7	26,4	8,5	34,5			1598	348	29871
LDG-30X-180Y-FC3-2	LDG-30X-180Y-FO3-2	2164	862	506	70	670	215	882	2 x 3/4"	2 x 3/4"	737	7,2	40500
		85,2	33,9	19,9	2,7	26,4	8,5	34,7			1625	439	29871
LDG-30X-200Y-FC3-2	LDG-30X-200Y-FO3-2	2238	936	506	70	670	215	956	2 x 3/4"	2 x 3/4"	753	8,9	40500
		88,1	36,8	19,9	2,7	26,4	8,5	37,6			1660	543	29871
LDG-30X-220Y-FC3-2	LDG-30X-220Y-FO3-2	2248	946	506	70	670	215	966	2 x 3/4"	2 x 3/4"	765	10,8	40500
		88,5	37,2	19,9	2,7	26,4	8,5	38,0			1687	659	29871
LDG-30X-120Y-FC3-3	LDG-30X-120Y-FO3-3	2149	847	506	70	670	215	867	2 x 1/2"	2 x 1/2"	715	3,2	40500
		84,6	33,3	19,9	2,7	26,4	8,5	34,1			1576	195	29871
LDG-30X-140Y-FC3-3	LDG-30X-140Y-FO3-3	2154	852	506	70	670	215	872	2 x 1/2"	2 x 1/2"	727	4,4	40500
		84,8	33,5	19,9	2,7	26,4	8,5	34,3			1603	269	29871
LDG-30X-160Y-FC3-3	LDG-30X-160Y-FO3-3	2159	857	506	70	670	215	877	2 x 1/2"	2 x 1/2"	739	5,7	40500
		85,0	33,7	19,9	2,7	26,4	8,5	34,5			1629	348	29871
LDG-30X-180Y-FC3-3	LDG-30X-180Y-FO3-3	2164	862	506	70	670	215	882	2 x 3/4"	2 x 3/4"	751	7,2	40500
		85,2	33,9	19,9	2,7	26,4	8,5	34,7			1656	439	29871
LDG-30X-200Y-FC3-3	LDG-30X-200Y-FO3-3	2238	936	506	70	670	215	956	2 x 3/4"	2 x 3/4"	767	8,9	40500
		88,1	36,8	19,9	2,7	26,4	8,5	37,6			1691	543	29871
LDG-30X-220Y-FC3-3	LDG-30X-220Y-FO3-3	2248	946	506	70	670	215	966	2 x 3/4"	2 x 3/4"	779	10,8	40500
		88,5	37,2	19,9	2,7	26,4	8,5	38,0			1717	659	29871
LDG-30X-120Y-FC4-1	LDG-30X-120Y-FO4-1	2173	847	568	101	670	215	867	2 x 1/2"	2 x 1/2"	765	3,2	40500
		85,6	33,3	22,4	4,0	26,4	8,5	34,1			1687	195	29871
LDG-30X-140Y-FC4-1	LDG-30X-140Y-FO4-1	2178	852	568	101	670	215	872	2 x 1/2"	2 x 1/2"	777	4,4	40500
		85,7	33,5	22,4	4,0	26,4	8,5	34,3			1713	269	29871
LDG-30X-160Y-FC4-1	LDG-30X-160Y-FO4-1	2183	857	568	101	670	215	877	2 x 1/2"	2 x 1/2"	789	5,7	40500
		85,9	33,7	22,4	4,0	26,4	8,5	34,5			1739	348	29871
LDG-30X-180Y-FC4-1	LDG-30X-180Y-FO4-1	2188	862	568	101	670	215	882	2 x 3/4"	2 x 3/4"	801	7,2	40500
		86,1	33,9	22,4	4,0	26,4	8,5	34,7			1766	439	29871
LDG-30X-200Y-FC4-1	LDG-30X-200Y-FO4-1	2262	936	568	101	670	215	956	2 x 3/4"	2 x 3/4"	817	8,9	40500
		89,0	36,8	22,4	4,0	26,4	8,5	37,6			1801	543	29871
LDG-30X-220Y-FC4-1	LDG-30X-220Y-FO4-1	2272	946	568	101	670	215	966	2 x 3/4"	2 x 3/4"	829	10,8	40500
		89,4	37,2	22,4	4,0	26,4	8,5	38,0			1828	659	29871
LDG-30X-140Y-FC4-2	LDG-30X-140Y-FO4-2	2178	852	568	101	670	215	872	2 x 1/2"	2 x 1/2"	809	4,4	40500
		85,7	33,5	22,4	4,0	26,4	8,5	34,3			1784	269	29871
LDG-30X-160Y-FC4-2	LDG-30X-160Y-FO4-2	2183	857	568	101	670	215	877	2 x 1/2"	2 x 1/2"	821	5,7	40500
		85,9	33,7	22,4	4,0	26,4	8,5	34,5			1810	348	29871
LDG-30X-180Y-FC4-2	LDG-30X-180Y-FO4-2	2188	862	568	101	670	215	882	2 x 3/4"				



Limitorque™ LDG Direct Gas Heavy-Duty Actuator Series FCD LFENTB0005-00-AQ - 06/16

LDG Single Acting - Dimensions: mm (in) - Weights: Kg (lbs) - Swept Volumes: l (cu in) - MOT: Nm (ft-lb)													
Model		a	b	c	d	e	f	g	"P" NPT PORT	"N" NPT PORT	Weight	Swept Volume*	MOT
LDG-30X-180Y-FC4-4	LDG-30X-180Y-FO4-4	2188	862	568	101	670	215	882	2 x 3/4"	2 x 3/4"	848	7,2	40500
		86,1	33,9	22,4	4,0	26,4	8,5	34,7			1870	439	29871
LDG-30X-200Y-FC4-4	LDG-30X-200Y-FO4-4	2262	936	568	101	670	215	956	2 x 3/4"	2 x 3/4"	864	8,9	40500
		89,0	36,8	22,4	4,0	26,4	8,5	37,6			1905	543	29871
LDG-30X-220Y-FC4-4	LDG-30X-220Y-FO4-4	2272	946	568	101	670	215	966	2 x 3/4"	2 x 3/4"	876	10,8	40500
		89,4	37,2	22,4	4,0	26,4	8,5	38,0			1931	659	29871
LDG-30X-140Y-FC4-5	LDG-30X-140Y-FO4-5	2178	852	568	101	670	215	872	2 x 1/2"	2 x 1/2"	832	4,4	40500
		85,7	33,5	22,4	4,0	26,4	8,5	34,3			1834	269	29871
LDG-30X-160Y-FC4-5	LDG-30X-160Y-FO4-5	2183	857	568	101	670	215	877	2 x 1/2"	2 x 1/2"	844	5,7	40500
		85,9	33,7	22,4	4,0	26,4	8,5	34,5			1861	348	29871
LDG-30X-180Y-FC4-5	LDG-30X-180Y-FO4-5	2188	862	568	101	670	215	882	2 x 3/4"	2 x 3/4"	856	7,2	40500
		86,1	33,9	22,4	4,0	26,4	8,5	34,7			1887	439	29871
LDG-30X-200Y-FC4-5	LDG-30X-200Y-FO4-5	2262	936	568	101	670	215	956	2 x 3/4"	2 x 3/4"	872	8,9	40500
		89,0	36,8	22,4	4,0	26,4	8,5	37,6			1922	543	29871
LDG-30X-220Y-FC4-5	LDG-30X-220Y-FO4-5	2272	946	568	101	670	215	966	2 x 3/4"	2 x 3/4"	884	10,8	40500
		89,4	37,2	22,4	4,0	26,4	8,5	38,0			1949	659	29871
LDG-30X-140Y-FC5-1	LDG-30X-140Y-FO5-1	2675	852	644	139	670	215	872	2 x 1/2"	2 x 1/2"	1014	4,4	40500
		105,3	33,5	25,4	5,5	26,4	8,5	34,3			2235	269	29871
LDG-30X-160Y-FC5-1	LDG-30X-160Y-FO5-1	2680	857	644	139	670	215	877	2 x 1/2"	2 x 1/2"	1026	5,7	40500
		105,5	33,7	25,4	5,5	26,4	8,5	34,5			2262	348	29871
LDG-30X-180Y-FC5-1	LDG-30X-180Y-FO5-1	2685	862	644	139	670	215	882	2 x 3/4"	2 x 3/4"	1038	7,2	40500
		105,7	33,9	25,4	5,5	26,4	8,5	34,7			2288	439	29871
LDG-30X-200Y-FC5-1	LDG-30X-200Y-FO5-1	2759	936	644	139	670	215	956	2 x 3/4"	2 x 3/4"	1054	8,9	40500
		108,6	36,8	25,4	5,5	26,4	8,5	37,6			2324	543	29871
LDG-30X-220Y-FC5-1	LDG-30X-220Y-FO5-1	2769	946	644	139	670	215	966	2 x 3/4"	2 x 3/4"	1066	10,8	40500
		109,0	37,2	25,4	5,5	26,4	8,5	38,0			2350	659	29871
LDG-30X-140Y-FC5-2	LDG-30X-140Y-FO5-2	2675	852	644	139	670	215	872	2 x 1/2"	2 x 1/2"	1121	4,4	40500
		105,3	33,5	25,4	5,5	26,4	8,5	34,3			2471	269	29871
LDG-30X-160Y-FC5-2	LDG-30X-160Y-FO5-2	2680	857	644	139	670	215	877	2 x 1/2"	2 x 1/2"	1133	5,7	40500
		105,5	33,7	25,4	5,5	26,4	8,5	34,5			2498	348	29871
LDG-30X-180Y-FC5-2	LDG-30X-180Y-FO5-2	2685	862	644	139	670	215	882	2 x 3/4"	2 x 3/4"	1145	7,2	40500
		105,7	33,9	25,4	5,5	26,4	8,5	34,7			2524	439	29871
LDG-30X-200Y-FC5-2	LDG-30X-200Y-FO5-2	2759	936	644	139	670	215	956	2 x 3/4"	2 x 3/4"	1161	8,9	40500
		108,6	36,8	25,4	5,5	26,4	8,5	37,6			2560	543	29871
LDG-30X-220Y-FC5-2	LDG-30X-220Y-FO5-2	2769	946	644	139	670	215	966	2 x 3/4"	2 x 3/4"	1173	10,8	40500
		109,0	37,2	25,4	5,5	26,4	8,5	38,0			2586	659	29871
LDG-30X-160Y-FC5-3	LDG-30X-160Y-FO5-3	2680	857	644	139	670	215	877	2 x 1/2"	2 x 1/2"	1133	5,7	40500
		105,5	33,7	25,4	5,5	26,4	8,5	34,5			2498	348	29871
LDG-30X-180Y-FC5-3	LDG-30X-180Y-FO5-3	2685	862	644	139	670	215	882	2 x 3/4"	2 x 3/4"	1145	7,2	40500
		105,7	33,9	25,4	5,5	26,4	8,5	34,7			2524	439	29871
LDG-30X-200Y-FC5-3	LDG-30X-200Y-FO5-3	2759	936	644	139	670	215	956	2 x 3/4"	2 x 3/4"	1161	8,9	40500
		108,6	36,8	25,4	5,5	26,4	8,5	37,6			2560	543	29871
LDG-30X-220Y-FC5-3	LDG-30X-220Y-FO5-3	2769	946	644	139	670	215	966	2 x 3/4"	2 x 3/4"	1173	10,8	40500
		109,0	37,2	25,4	5,5	26,4	8,5	38,0			2586	659	29871
LDG-35X-100Y-FC1-2	LDG-35X-100Y-FO1-2	3000	1029	490	29	849	260	1049	2 x 1/2"	2 x 1/2"	1172	2,7	75000
		118,1	40,5	19,3	1,1	33,4	10,2	41,3			2583	165	51661
LDG-35X-110Y-FC1-2	LDG-35X-110Y-FO1-2	3005	1034	490	29	849	260	1054	2 x 1/2"	2 x 1/2"	1179	3,3	75000
		118,3	40,7	19,3	1,1	33,4	10,2	41,5			2599	201	51661
LDG-35X-120Y-FC1-2	LDG-35X-120Y-FO1-2	3010	1039	490	29	849	260	1059	2 x 1/2"	2 x 1/2"	1186	3,9	75000
		118,5	40,9	19,3	1,1	33,4	10,2	41,7			2615	238	51661
LDG-35X-140Y-FC1-2	LDG-35X-140Y-FO1-2	3015	1044	490	29	849	260	1064	2 x 1/2"	2 x 1/2"	1201	5,3	75000
		118,7	41,1	19,3	1,1	33,4	10,2	41,9			2647	323	51661
LDG-35X-160Y-FC1-2	LDG-35X-160Y-FO1-2	3020	1049	490	29	849	260	1069	2 x 1/2"	2 x 1/2"	1215	7,0	75000
		118,9	41,3	19,3	1,1	33,4	10,2	42,1			2679	427	51661
LDG-35X-180Y-FC1-2	LDG-35X-180Y-FO1-2	3025	1054	490	29	849	260	1074	2 x 3/4"	2 x 3/4"	1230	8,8	75000
		119,1	41,5	19,3	1,1	33,4	10,2	42,3			2711	537	51661
LDG-35X-200Y-FC1-2	LDG-35X-200Y-FO1-2	3028	1057	490	29	849	260	1077	2 x 3/4"	2 x 3/4"	1248	10,9	75000
		119,2	41,6	19,3	1,1	33,4	10,2	42,4			2751	665	51661
LDG-35X-220Y-FC1-2	LDG-35X-220Y-FO1-2	3140	1169	490	29	849	260	1189	2 x 3/4"	2 x 3/4"	1262	13,2	75000
		123,6	46,0	19,3	1,1	33,4	10,2	46,8			2783	806	51661
LDG-35X-240Y-FC1-2	LDG-35X-240Y-FO1-2	3140	1169	490	29	849	260	1189	2 x 3/4"	2 x 3/4"	1286	15,7	75000
		123,6	46,0	19,3	1,1	33,4	10,2	46,8			2835	958	51661
LDG-35X-260Y-FC1-2	LDG-35X-260Y-FO1-2	3145	1174	490	29	849	260	1194	2 x 3/4"	2 x 3/4"	1300	18,4	75000
		123,8	46,2	19,3	1,1	33,4	10,2	47,0			2867	1123	51661
LDG-35X-280Y-FC1-2	LDG-35X-280Y-FO1-2	3145	1174	490	29	849	260	1194	2 x 3/4"	2 x 3/4"	1315	21,3	75000
		123,8	46,2	19,3	1,1	33,4	10,2	47,0			2899	1300	51661
LDG-35X-110Y-FC1-3	LDG-35X-110Y-FO1-3	3005	1034	490	29	849	260	1054	2 x 1/2"	2 x 1/2"	1218	3,3	75000
		118,3	40,7	19,3	1,1	33,4	10,2	41,5			2685	201	51661
LDG-35X-120Y-FC1-3	LDG-35X-120Y-FO1-3	3010	1039	490	29	849	260	1059	2 x 1/2"	2 x 1/2"	1225	3,9	75000
		118,5	40,9	19,3	1,1	33,4	10,2	41,7			2701	238	51661
LDG-35X-140Y-FC1-3	LDG-35X-140Y-FO1-3	3015	1044	490	29	849	260	1064	2 x 1/2"	2 x 1/2"	1240	5,3	75000
		118,7	41,1	19,3	1,1	33,4	10,2	41,9			2733	323	51661
LDG-35X-160Y-FC1-3	LDG-35X-160Y-FO1-3	3020	1049	490	29	849	260	1069	2 x 1/2"	2 x 1/2"	1254	7,0	75000
		118,9	41,3	19,3	1,1	33,4	10,2	42,1			2765	427	51661
LDG-35X-180Y-FC1-3	LDG-35X-180Y-FO1-3	3025	1054	490	29	849	260	1074	2 x 3/4"	2 x 3/4"	1269	8,8	75000
		119,1	41,5	19,3	1,1	33,4	10,2	42,3			2797	537	51661
LDG-35X-200Y-FC1-3	LDG-35X-200Y-FO1-3	3028	1057	490	29	849	260	1077	2 x 3/4"	2 x 3/4"	1287	10,9	75000
		119,2	41,6	19,3	1,1	33,4	10,2	42,4			2837	665	51661
LDG-35X-220Y-FC1-3	LDG-35X-220Y-FO1-3	3140	1169	490	29	849	260	1189	2 x 3/4"	2 x 3/4"	1301	13,2	75000
		123,6	46,0	19,3	1,1	33,4	10,2	46,8			2869	806	51661
LDG-35X-240Y-FC1-3	LDG-35X-240Y-FO1-3	3140	1169	490	29	849	260	1189	2 x 3/4"	2 x 3/4"	1325	15,7	75000
		123,6	46,0	19,3	1,1	33,4	10,2	46,8			2921	958	51661
LDG-35X-260Y-FC1-3	LDG-35X-260Y-FO1-3	3145	1174	490	29	849	260	1194	2 x 3/4"	2 x 3/4"	1339	18,4	75000
		123,8	46,2	19,3	1,1	33,4	10,2	47,0			2953		



Limitorque™ LDG Direct Gas Heavy-Duty Actuator Series FCD LFENTB0005-00-AQ - 06/16

LDG Single Acting - Dimensions: mm (in) - Weights: Kg (lbs) - Swept Volumes: l (cu in) - MOT: Nm (ft-lb)													
Model		a	b	c	d	e	f	g	"P" NPT PORT	"N" NPT PORT	Weight	Swept Volume*	MOT
LDG-35X-140Y-FC1-5	LDG-35X-140Y-FO1-5	3015	1044	490	29	849	260	1064	2 x 1/2"	2 x 1/2"	1369	5.3	75000
		118.7	41.1	19.3	1.1	33.4	10.2	41.9			3017	323	51661
		3020	1049	490	29	849	260	1069			1383	7.0	75000
LDG-35X-160Y-FC1-5	LDG-35X-160Y-FO1-5	118.9	41.3	19.3	1.1	33.4	10.2	42.1	2 x 1/2"	2 x 1/2"	3049	427	51661
		3025	1054	490	29	849	260	1074			1398	8.8	75000
		119.1	41.5	19.3	1.1	33.4	10.2	42.3			3081	537	51661
LDG-35X-180Y-FC1-5	LDG-35X-180Y-FO1-5	3028	1057	490	29	849	260	1077	2 x 3/4"	2 x 3/4"	1416	10.9	75000
		119.2	41.6	19.3	1.1	33.4	10.2	42.4			3122	665	51661
		3140	1169	490	29	849	260	1189			1430	13.2	75000
LDG-35X-200Y-FC1-5	LDG-35X-200Y-FO1-5	123.6	46.0	19.3	1.1	33.4	10.2	46.8	2 x 3/4"	2 x 3/4"	3154	806	51661
		3140	1169	490	29	849	260	1189			1454	15.7	75000
		123.6	46.0	19.3	1.1	33.4	10.2	46.8			3205	958	51661
LDG-35X-240Y-FC1-5	LDG-35X-240Y-FO1-5	3145	1174	490	29	849	260	1194	2 x 3/4"	2 x 3/4"	1468	18.4	75000
		123.8	46.2	19.3	1.1	33.4	10.2	47.0			3237	1123	51661
		3145	1174	490	29	849	260	1194			1483	21.3	75000
LDG-35X-260Y-FC1-5	LDG-35X-260Y-FO1-5	123.8	46.2	19.3	1.1	33.4	10.2	47.0	2 x 3/4"	2 x 3/4"	3269	1300	51661
		3015	1044	490	29	849	260	1064			1462	5.3	75000
		123.8	46.2	19.3	1.1	33.4	10.2	47.0			3222	323	51661
LDG-35X-280Y-FC1-5	LDG-35X-280Y-FO1-5	3020	1049	490	29	849	260	1069	2 x 1/2"	2 x 1/2"	1476	7.0	75000
		118.9	41.3	19.3	1.1	33.4	10.2	42.1			3254	427	51661
		3025	1054	490	29	849	260	1074			1491	8.8	75000
LDG-35X-140Y-FC2-1	LDG-35X-140Y-FO2-1	119.1	41.5	25.4	4.2	33.4	10.2	42.3	2 x 3/4"	2 x 3/4"	3286	537	51661
		3028	1057	490	29	849	260	1077			1509	10.9	75000
		119.2	41.6	25.4	4.2	33.4	10.2	42.4			3327	665	51661
LDG-35X-160Y-FC2-1	LDG-35X-160Y-FO2-1	3140	1169	490	29	849	260	1189	2 x 3/4"	2 x 3/4"	1523	13.2	75000
		123.6	46.0	25.4	4.2	33.4	10.2	46.8			3359	806	51661
		3140	1169	490	29	849	260	1189			1547	15.7	75000
LDG-35X-180Y-FC2-1	LDG-35X-180Y-FO2-1	123.6	46.0	25.4	4.2	33.4	10.2	46.8	2 x 3/4"	2 x 3/4"	3410	958	51661
		3145	1174	490	29	849	260	1194			1561	18.4	75000
		123.8	46.2	25.4	4.2	33.4	10.2	47.0			3442	1123	51661
LDG-35X-200Y-FC2-1	LDG-35X-200Y-FO2-1	3145	1174	490	29	849	260	1194	2 x 3/4"	2 x 3/4"	1576	21.3	75000
		123.8	46.2	25.4	4.2	33.4	10.2	47.0			3474	1300	51661
		3015	1044	490	29	849	260	1064			1569	5.3	75000
LDG-35X-240Y-FC2-1	LDG-35X-240Y-FO2-1	118.7	41.1	25.4	4.2	33.4	10.2	41.9	2 x 1/2"	2 x 1/2"	3458	323	51661
		3020	1049	490	29	849	260	1069			1583	7.0	75000
		118.9	41.3	25.4	4.2	33.4	10.2	42.1			3490	427	51661
LDG-35X-260Y-FC2-1	LDG-35X-260Y-FO2-1	3025	1054	490	29	849	260	1074	2 x 3/4"	2 x 3/4"	1598	8.8	75000
		119.1	41.5	25.4	4.2	33.4	10.2	42.3			3522	537	51661
		3028	1057	490	29	849	260	1077			1616	10.9	75000
LDG-35X-280Y-FC2-1	LDG-35X-280Y-FO2-1	119.2	41.6	25.4	4.2	33.4	10.2	42.4	2 x 3/4"	2 x 3/4"	3563	665	51661
		3140	1169	490	29	849	260	1189			1630	13.2	75000
		123.6	46.0	25.4	4.2	33.4	10.2	46.8			3595	806	51661
LDG-35X-140Y-FC2-2	LDG-35X-140Y-FO2-2	3140	1169	490	29	849	260	1189	2 x 3/4"	2 x 3/4"	1654	15.7	75000
		123.6	46.0	25.4	4.2	33.4	10.2	46.8			3646	958	51661
		3145	1174	490	29	849	260	1194			1668	18.4	75000
LDG-35X-160Y-FC2-2	LDG-35X-160Y-FO2-2	123.8	46.2	25.4	4.2	33.4	10.2	47.0	2 x 3/4"	2 x 3/4"	3678	1123	51661
		3145	1174	490	29	849	260	1194			1683	21.3	75000
		123.8	46.2	25.4	4.2	33.4	10.2	47.0			3710	1300	51661
LDG-35X-180Y-FC2-2	LDG-35X-180Y-FO2-2	3020	1049	490	29	849	260	1069	2 x 1/2"	2 x 1/2"	1672	7.0	75000
		118.9	41.3	25.4	4.2	33.4	10.2	42.1			3686	427	51661
		3025	1054	490	29	849	260	1074			1687	8.8	75000
LDG-35X-200Y-FC2-2	LDG-35X-200Y-FO2-2	119.1	41.5	25.4	4.2	33.4	10.2	42.3	2 x 3/4"	2 x 3/4"	3718	537	51661
		3028	1057	490	29	849	260	1077			1705	10.9	75000
		119.2	41.6	25.4	4.2	33.4	10.2	42.4			3759	665	51661
LDG-35X-240Y-FC2-2	LDG-35X-240Y-FO2-2	3140	1169	490	29	849	260	1189	2 x 3/4"	2 x 3/4"	1719	13.2	75000
		123.6	46.0	25.4	4.2	33.4	10.2	46.8			3791	806	51661
		3140	1169	490	29	849	260	1189			1743	15.7	75000
LDG-35X-260Y-FC2-2	LDG-35X-260Y-FO2-2	123.6	46.0	25.4	4.2	33.4	10.2	46.8	2 x 3/4"	2 x 3/4"	3842	958	51661
		3145	1174	490	29	849	260	1194			1757	18.4	75000
		123.8	46.2	25.4	4.2	33.4	10.2	47.0			3874	1123	51661
LDG-35X-280Y-FC2-2	LDG-35X-280Y-FO2-2	3145	1174	490	29	849	260	1194	2 x 3/4"	2 x 3/4"	1772	21.3	75000
		123.8	46.2	25.4	4.2	33.4	10.2	47.0			3906	1300	51661
		3020	1049	490	29	849	260	1069			1774	7.0	75000
LDG-35X-160Y-FC3-1	LDG-35X-160Y-FO3-1	118.9	41.3	26.9	5.0	33.4	10.2	42.1	2 x 1/2"	2 x 1/2"	3911	427	51661
		3025	1054	490	29	849	260	1074			1789	8.8	75000
		119.1	41.5	26.9	5.0	33.4	10.2	42.3			3943	537	51661
LDG-35X-180Y-FC3-1	LDG-35X-180Y-FO3-1	3028	1057	490	29	849	260	1077	2 x 3/4"	2 x 3/4"	1807	10.9	75000
		119.2	41.6	26.9	5.0	33.4	10.2	42.4			3984	665	51661
		3140	1169	490	29	849	260	1189			1821	13.2	75000
LDG-35X-200Y-FC3-1	LDG-35X-200Y-FO3-1	123.6	46.0	26.9	5.0	33.4	10.2	46.8	2 x 3/4"	2 x 3/4"	4016	806	51661
		3140	1169	490	29	849	260	1189			1845	15.7	75000
		123.6	46.0	26.9	5.0	33.4	10.2	46.8			4067	958	51661
LDG-35X-240Y-FC3-1	LDG-35X-240Y-FO3-1	3145	1174	490	29	849	260	1194	2 x 3/4"	2 x 3/4"	1859	18.4	75000
		123.8	46.2	26.9	5.0	33.4	10.2	47.0			4099	1123	51661
		3145	1174	490	29	849	260	1194			1874	21.3	75000
LDG-35X-260Y-FC3-1	LDG-35X-260Y-FO3-1	123.8	46.2	26.9	5.0	33.4	10.2	47.0	2 x 3/4"	2 x 3/4"	4131	1300	51661
		3025	1054	490	29	849	260	1074			1973	8.8	75000
		119.1	41.5	26.9	5.0	33.4	10.2	42.3			4349	537	51661
LDG-35X-280Y-FC3-1	LDG-35X-280Y-FO3-1	3028	1057	490	29	849	260	1077	2 x 3/4"	2 x 3/4"	1991	10.9	75000
		119.2	41.6	26.9	5.0	33.4	10.2	42.4			4389	665	51661
		3140	1169	490	29	849	260	1189			2005	13.2	75000
LDG-35X-160Y-FC3-2	LDG-35X-160Y-FO3-2	123.6	46.0	26.9	5.0	33.4	10.2	46.8	2 x 3/4"	2 x 3/4"	4421	806	51661
		3140	1169	490	29	849	260	1189			2029	15.7	75000
		123.6	46.0	26.9	5.0	33.4	10.2	46.8			4473	958	51661
LDG-35X-180Y-FC3-2	LDG-35X-180Y-FO3-2	3145	1174	490	29	849	260	1194	2 x 3/4"	2 x 3/4"	2043	18.4	75000
		123.8	46.2	26.9	5.0	33.4	10.2	47.0			4505	1123	51661
		3145	1174	490	29	849	260	1194			2058	21.3	75000
LDG-35X-200Y-FC3-2	LDG-35X-200Y-FO3-2	123.8	46.2	26.9	5.0	33.4	10.2	47.0	2 x 3/4"	2 x 3/4"	4537	1300	51661
		3025	1054	490	29	849	260	1074			2033	8.8	75000
		119.1	41.5	26.9	5.0	33.4	10.2	42.3			4481	537	51661
LDG-35X-240Y-FC3-2	LDG-35X-240Y-FO3-2	3028	1057	490	29	849	260	1077	2 x 3/4"	2 x 3/4"	2051	10.9	75000
		119.2	41.6	26.9	5.0								



Limitorque™ LDG Direct Gas Heavy-Duty Actuator Series FCD LFENTB0005-00-AQ - 06/16

LDG Single Acting - Dimensions: mm (in) - Weights: Kg (lbs) - Swept Volumes: l (cu in) - MOT: Nm (ft-lb)													
Model	a	b	c	d	e	f	g	"P" NPT PORT	"N" NPT PORT	Weight	Swept Volume*	MOT	
LDG-35X-240Y-FC3-4	LDG-35X-240Y-FO3-4	3140	1169	684	126	849	260	1189	2 x 3/4"	2 x 3/4"	2074	15,7	75000
		123,6	46,0	26,9	5,0	33,4	10,2	46,8			4572	958	51661
LDG-35X-260Y-FC3-4	LDG-35X-260Y-FO3-4	3145	1174	684	126	849	260	1194	2 x 3/4"	2 x 3/4"	2088	18,4	75000
		123,8	46,2	26,9	5,0	33,4	10,2	47,0			4604	1123	51661
LDG-35X-280Y-FC3-4	LDG-35X-280Y-FO3-4	3145	1174	684	126	849	260	1194	2 x 3/4"	2 x 3/4"	2103	21,3	75000
		123,8	46,2	26,9	5,0	33,4	10,2	47,0			4636	1300	51661
LDG-40X-120Y-FC1-1	LDG-40X-120Y-FO1-1	3616	1261	494	7	953	290	1285	2 x 1/2"	2 x 1/2"	1756	4,7	150000
		142,4	49,6	19,4	0,3	37,5	11,4	50,6			3871	287	103321
LDG-40X-140Y-FC1-1	LDG-40X-140Y-FO1-1	3619	1264	494	7	953	290	1288	2 x 1/2"	2 x 1/2"	1773	6,5	150000
		142,5	49,8	19,4	0,3	37,5	11,4	50,7			3909	397	103321
LDG-40X-160Y-FC1-1	LDG-40X-160Y-FO1-1	3619	1264	494	7	953	290	1288	2 x 1/2"	2 x 1/2"	1790	8,4	150000
		142,5	49,8	19,4	0,3	37,5	11,4	50,7			3946	513	103321
LDG-40X-180Y-FC1-1	LDG-40X-180Y-FO1-1	3619	1264	494	7	953	290	1288	2 x 3/4"	2 x 3/4"	1807	10,7	150000
		142,5	49,8	19,4	0,3	37,5	11,4	50,7			3984	653	103321
LDG-40X-200Y-FC1-1	LDG-40X-200Y-FO1-1	3619	1264	494	7	953	290	1288	2 x 3/4"	2 x 3/4"	1828	13,2	150000
		142,5	49,8	19,4	0,3	37,5	11,4	50,7			4030	806	103321
LDG-40X-220Y-FC1-1	LDG-40X-220Y-FO1-1	3622	1267	494	7	953	290	1291	2 x 3/4"	2 x 3/4"	1845	16,0	150000
		142,6	49,9	19,4	0,3	37,5	11,4	50,8			4068	976	103321
LDG-40X-240Y-FC1-1	LDG-40X-240Y-FO1-1	3622	1267	494	7	953	290	1291	2 x 3/4"	2 x 3/4"	1871	19,0	150000
		142,6	49,9	19,4	0,3	37,5	11,4	50,8			4125	1159	103321
LDG-40X-260Y-FC1-1	LDG-40X-260Y-FO1-1	3808	1453	494	7	953	290	1477	2 x 3/4"	2 x 3/4"	1888	22,3	150000
		149,9	57,2	19,4	0,3	37,5	11,4	58,1			4163	1361	103321
LDG-40X-280Y-FC1-1	LDG-40X-280Y-FO1-1	3808	1453	494	7	953	290	1477	2 x 3/4"	2 x 3/4"	1905	25,8	150000
		149,9	57,2	19,4	0,3	37,5	11,4	58,1			4200	1574	103321
LDG-40X-300Y-FC1-1	LDG-40X-300Y-FO1-1	3813	1458	500	13	953	290	1482	2 x 3/4"	2 x 3/4"	1927	29,7	150000
		150,1	57,4	19,7	0,5	37,5	11,4	58,3			4249	1812	103321
LDG-40X-320Y-FC1-1	LDG-40X-320Y-FO1-1	3813	1458	505	18	953	290	1482	2 x 3/4"	2 x 3/4"	1944	33,8	150000
		150,1	57,4	19,9	0,7	37,5	11,4	58,3			4286	2063	103321
LDG-40X-340Y-FC1-1	LDG-40X-340Y-FO1-1	3813	1458	510	23	953	290	1482	2 x 3/4"	2 x 3/4"	1961	38,1	150000
		150,1	57,4	20,1	0,9	37,5	11,4	58,3			4324	2325	103321
LDG-40X-140Y-FC1-3	LDG-40X-140Y-FO1-3	3619	1264	494	7	953	290	1288	2 x 1/2"	2 x 1/2"	1884	6,5	150000
		142,5	49,8	19,4	0,3	37,5	11,4	50,7			4154	397	103321
LDG-40X-160Y-FC1-3	LDG-40X-160Y-FO1-3	3619	1264	494	7	953	290	1288	2 x 1/2"	2 x 1/2"	1901	8,4	150000
		142,5	49,8	19,4	0,3	37,5	11,4	50,7			4191	513	103321
LDG-40X-180Y-FC1-3	LDG-40X-180Y-FO1-3	3619	1264	494	7	953	290	1288	2 x 3/4"	2 x 3/4"	1918	10,7	150000
		142,5	49,8	19,4	0,3	37,5	11,4	50,7			4229	653	103321
LDG-40X-200Y-FC1-3	LDG-40X-200Y-FO1-3	3619	1264	494	7	953	290	1288	2 x 3/4"	2 x 3/4"	1939	13,2	150000
		142,5	49,8	19,4	0,3	37,5	11,4	50,7			4275	806	103321
LDG-40X-220Y-FC1-3	LDG-40X-220Y-FO1-3	3622	1267	494	7	953	290	1291	2 x 3/4"	2 x 3/4"	1956	16,0	150000
		142,6	49,9	19,4	0,3	37,5	11,4	50,8			4312	976	103321
LDG-40X-240Y-FC1-3	LDG-40X-240Y-FO1-3	3622	1267	494	7	953	290	1291	2 x 3/4"	2 x 3/4"	1982	19,0	150000
		142,6	49,9	19,4	0,3	37,5	11,4	50,8			4370	1159	103321
LDG-40X-260Y-FC1-3	LDG-40X-260Y-FO1-3	3808	1453	494	7	953	290	1477	2 x 3/4"	2 x 3/4"	1999	22,3	150000
		149,9	57,2	19,4	0,3	37,5	11,4	58,1			4407	1361	103321
LDG-40X-280Y-FC1-3	LDG-40X-280Y-FO1-3	3808	1453	494	7	953	290	1477	2 x 3/4"	2 x 3/4"	2016	25,8	150000
		149,9	57,2	19,4	0,3	37,5	11,4	58,1			4445	1574	103321
LDG-40X-300Y-FC1-3	LDG-40X-300Y-FO1-3	3813	1458	500	13	953	290	1482	2 x 3/4"	2 x 3/4"	2038	29,7	150000
		150,1	57,4	19,7	0,5	37,5	11,4	58,3			4493	1812	103321
LDG-40X-320Y-FC1-3	LDG-40X-320Y-FO1-3	3813	1458	505	18	953	290	1482	2 x 3/4"	2 x 3/4"	2055	33,8	150000
		150,1	57,4	19,9	0,7	37,5	11,4	58,3			4531	2063	103321
LDG-40X-340Y-FC1-3	LDG-40X-340Y-FO1-3	3813	1458	510	23	953	290	1482	2 x 3/4"	2 x 3/4"	2072	38,1	150000
		150,1	57,4	20,1	0,9	37,5	11,4	58,3			4569	2325	103321
LDG-40X-140Y-FC2-1	LDG-40X-140Y-FO2-1	3619	1264	654	91	953	290	1288	2 x 1/2"	2 x 1/2"	2061	6,5	150000
		142,5	49,8	25,7	3,6	37,5	11,4	50,7			4544	397	103321
LDG-40X-160Y-FC2-1	LDG-40X-160Y-FO2-1	3619	1264	654	91	953	290	1288	2 x 1/2"	2 x 1/2"	2078	8,4	150000
		142,5	49,8	25,7	3,6	37,5	11,4	50,7			4581	513	103321
LDG-40X-180Y-FC2-1	LDG-40X-180Y-FO2-1	3619	1264	654	91	953	290	1288	2 x 3/4"	2 x 3/4"	2095	10,7	150000
		142,5	49,8	25,7	3,6	37,5	11,4	50,7			4619	653	103321
LDG-40X-200Y-FC2-1	LDG-40X-200Y-FO2-1	3619	1264	654	91	953	290	1288	2 x 3/4"	2 x 3/4"	2116	13,2	150000
		142,5	49,8	25,7	3,6	37,5	11,4	50,7			4665	806	103321
LDG-40X-220Y-FC2-1	LDG-40X-220Y-FO2-1	3622	1267	654	91	953	290	1291	2 x 3/4"	2 x 3/4"	2133	16,0	150000
		142,6	49,9	25,7	3,6	37,5	11,4	50,8			4703	976	103321
LDG-40X-240Y-FC2-1	LDG-40X-240Y-FO2-1	3622	1267	654	91	953	290	1291	2 x 3/4"	2 x 3/4"	2159	19,0	150000
		142,6	49,9	25,7	3,6	37,5	11,4	50,8			4760	1159	103321
LDG-40X-260Y-FC2-1	LDG-40X-260Y-FO2-1	3808	1453	654	91	953	290	1477	2 x 3/4"	2 x 3/4"	2176	22,3	150000
		149,9	57,2	25,7	3,6	37,5	11,4	58,1			4798	1361	103321
LDG-40X-280Y-FC2-1	LDG-40X-280Y-FO2-1	3808	1453	654	91	953	290	1477	2 x 3/4"	2 x 3/4"	2193	25,8	150000
		149,9	57,2	25,7	3,6	37,5	11,4	58,1			4835	1574	103321
LDG-40X-300Y-FC2-1	LDG-40X-300Y-FO2-1	3813	1458	654	91	953	290	1482	2 x 3/4"	2 x 3/4"	2215	29,7	150000
		150,1	57,4	25,7	3,6	37,5	11,4	58,3			4884	1812	103321
LDG-40X-320Y-FC2-1	LDG-40X-320Y-FO2-1	3813	1458	654	91	953	290	1482	2 x 3/4"	2 x 3/4"	2232	33,8	150000
		150,1	57,4	25,7	3,6	37,5	11,4	58,3			4921	2063	103321
LDG-40X-340Y-FC2-1	LDG-40X-340Y-FO2-1	3813	1458	654	91	953	290	1482	2 x 3/4"	2 x 3/4"	2249	38,1	150000
		150,1	57,4	25,7	3,6	37,5	11,4	58,3			4959	2325	103321
LDG-40X-160Y-FC2-2	LDG-40X-160Y-FO2-2	3619	1264	654	91	953	290	1288	2 x 1/2"	2 x 1/2"	2180	8,4	150000
		142,5	49,8	25,7	3,6	37,5	11,4	50,7			4806	513	103321
LDG-40X-180Y-FC2-2	LDG-40X-180Y-FO2-2	3619	1264	654	91	953	290	1288	2 x 3/4"	2 x 3/4"	2197	10,7	150000
		142,5	49,8	25,7	3,6	37,5	11,4	50,7			4844	653	103321
LDG-40X-200Y-FC2-2	LDG-40X-200Y-FO2-2	3619	1264	654	91	953	290	1288	2 x 3/4"	2 x 3/4"	2218	13,2	150000
		142,5	49,8	25,7	3,6	37,5	11,4	50,7			4890	806	103321
LDG-40X-220Y-FC2-2	LDG-40X-220Y-FO2-2	3622	1267	654	91	953	290	1291	2 x 3/4"	2 x 3/4"	2235	16,0	150000
		142,6	49,9	25,7	3,6	37,5	11,4	50,8			4928	976	103321
LDG-40X-240Y-FC2-2	LDG-40X-240Y-FO2-2	3622	1267	654	91	953	290	1					



Limitorque™ LDG Direct Gas Heavy-Duty Actuator Series FCD LFENTB0005-00-AQ - 06/16

LDG Single Acting - Dimensions: mm (in) - Weights: Kg (lbs) - Swept Volumes: l (cu in) - MOT: Nm (ft-lb)													
Model	a	b	c	d	e	f	g	"P" NPT PORT	"N" NPT PORT	Weight	Swept Volume*	MOT	
LDG-40X-260Y-FC2-3	LDG-40X-260Y-FO2-3	3808	1453	654	91	953	290	1477	2 x 3/4"	2 x 3/4"	2362	22,3	150000
		149,9	57,2	25,7	3,6	37,5	11,4	58,1			5208	1361	103321
LDG-40X-280Y-FC2-3	LDG-40X-280Y-FO2-3	3808	1453	654	91	953	290	1477	2 x 3/4"	2 x 3/4"	2379	25,8	150000
		149,9	57,2	25,7	3,6	37,5	11,4	58,1			5245	1574	103321
LDG-40X-300Y-FC2-3	LDG-40X-300Y-FO2-3	3813	1458	654	91	953	290	1482	2 x 3/4"	2 x 3/4"	2401	29,7	150000
		150,1	57,4	25,7	3,6	37,5	11,4	58,3			5294	1812	103321
LDG-40X-320Y-FC2-3	LDG-40X-320Y-FO2-3	3813	1458	654	91	953	290	1482	2 x 3/4"	2 x 3/4"	2418	33,8	150000
		150,1	57,4	25,7	3,6	37,5	11,4	58,3			5331	2063	103321
LDG-40X-340Y-FC2-3	LDG-40X-340Y-FO2-3	3813	1458	654	91	953	290	1482	2 x 3/4"	2 x 3/4"	2435	38,1	150000
		150,1	57,4	25,7	3,6	37,5	11,4	58,3			5369	2325	103321
LDG-40X-160Y-FC3-1	LDG-40X-160Y-FO3-1	3619	1264	688	105	953	290	1288	2 x 1/2"	2 x 1/2"	2365	8,4	150000
		142,5	49,8	27,1	4,1	37,5	11,4	50,7			5214	513	103321
LDG-40X-180Y-FC3-1	LDG-40X-180Y-FO3-1	3619	1264	688	105	953	290	1288	2 x 3/4"	2 x 3/4"	2382	10,7	150000
		142,5	49,8	27,1	4,1	37,5	11,4	50,7			5252	653	103321
LDG-40X-200Y-FC3-1	LDG-40X-200Y-FO3-1	3619	1264	688	105	953	290	1288	2 x 3/4"	2 x 3/4"	2403	13,2	150000
		142,5	49,8	27,1	4,1	37,5	11,4	50,7			5298	806	103321
LDG-40X-220Y-FC3-1	LDG-40X-220Y-FO3-1	3622	1267	688	105	953	290	1291	2 x 3/4"	2 x 3/4"	2420	16,0	150000
		142,6	49,9	27,1	4,1	37,5	11,4	50,8			5335	976	103321
LDG-40X-240Y-FC3-1	LDG-40X-240Y-FO3-1	3622	1267	688	105	953	290	1291	2 x 3/4"	2 x 3/4"	2446	19,0	150000
		142,6	49,9	27,1	4,1	37,5	11,4	50,8			5393	1159	103321
LDG-40X-260Y-FC3-1	LDG-40X-260Y-FO3-1	3808	1453	688	105	953	290	1477	2 x 3/4"	2 x 3/4"	2463	22,3	150000
		149,9	57,2	27,1	4,1	37,5	11,4	58,1			5430	1361	103321
LDG-40X-280Y-FC3-1	LDG-40X-280Y-FO3-1	3808	1453	688	105	953	290	1477	2 x 3/4"	2 x 3/4"	2480	25,8	150000
		149,9	57,2	27,1	4,1	37,5	11,4	58,1			5468	1574	103321
LDG-40X-300Y-FC3-1	LDG-40X-300Y-FO3-1	3813	1458	688	105	953	290	1482	2 x 3/4"	2 x 3/4"	2502	29,7	150000
		150,1	57,4	27,1	4,1	37,5	11,4	58,3			5516	1812	103321
LDG-40X-320Y-FC3-1	LDG-40X-320Y-FO3-1	3813	1458	688	105	953	290	1482	2 x 3/4"	2 x 3/4"	2519	33,8	150000
		150,1	57,4	27,1	4,1	37,5	11,4	58,3			5554	2063	103321
LDG-40X-340Y-FC3-1	LDG-40X-340Y-FO3-1	3813	1458	688	105	953	290	1482	2 x 3/4"	2 x 3/4"	2536	38,1	150000
		150,1	57,4	27,1	4,1	37,5	11,4	58,3			5591	2325	103321
LDG-40X-180Y-FC3-2	LDG-40X-180Y-FO3-2	3619	1264	688	105	953	290	1288	2 x 3/4"	2 x 3/4"	2560	10,7	150000
		142,5	49,8	27,1	4,1	37,5	11,4	50,7			5644	653	103321
LDG-40X-200Y-FC3-2	LDG-40X-200Y-FO3-2	3619	1264	688	105	953	290	1288	2 x 3/4"	2 x 3/4"	2581	13,2	150000
		142,5	49,8	27,1	4,1	37,5	11,4	50,7			5690	806	103321
LDG-40X-220Y-FC3-2	LDG-40X-220Y-FO3-2	3622	1267	688	105	953	290	1291	2 x 3/4"	2 x 3/4"	2598	16,0	150000
		142,6	49,9	27,1	4,1	37,5	11,4	50,8			5728	976	103321
LDG-40X-240Y-FC3-2	LDG-40X-240Y-FO3-2	3622	1267	688	105	953	290	1291	2 x 3/4"	2 x 3/4"	2624	19,0	150000
		142,6	49,9	27,1	4,1	37,5	11,4	50,8			5785	1159	103321
LDG-40X-260Y-FC3-2	LDG-40X-260Y-FO3-2	3808	1453	688	105	953	290	1477	2 x 3/4"	2 x 3/4"	2641	22,3	150000
		149,9	57,2	27,1	4,1	37,5	11,4	58,1			5823	1361	103321
LDG-40X-280Y-FC3-2	LDG-40X-280Y-FO3-2	3808	1453	688	105	953	290	1477	2 x 3/4"	2 x 3/4"	2658	25,8	150000
		149,9	57,2	27,1	4,1	37,5	11,4	58,1			5860	1574	103321
LDG-40X-300Y-FC3-2	LDG-40X-300Y-FO3-2	3813	1458	688	105	953	290	1482	2 x 3/4"	2 x 3/4"	2680	29,7	150000
		150,1	57,4	27,1	4,1	37,5	11,4	58,3			5909	1812	103321
LDG-40X-320Y-FC3-2	LDG-40X-320Y-FO3-2	3813	1458	688	105	953	290	1482	2 x 3/4"	2 x 3/4"	2697	33,8	150000
		150,1	57,4	27,1	4,1	37,5	11,4	58,3			5946	2063	103321
LDG-40X-340Y-FC3-2	LDG-40X-340Y-FO3-2	3813	1458	688	105	953	290	1482	2 x 3/4"	2 x 3/4"	2714	38,1	150000
		150,1	57,4	27,1	4,1	37,5	11,4	58,3			5984	2325	103321
LDG-40X-180Y-FC3-3	LDG-40X-180Y-FO3-3	3619	1264	688	105	953	290	1288	2 x 3/4"	2 x 3/4"	2622	10,7	150000
		142,5	49,8	27,1	4,1	37,5	11,4	50,7			5781	653	103321
LDG-40X-200Y-FC3-3	LDG-40X-200Y-FO3-3	3619	1264	688	105	953	290	1288	2 x 3/4"	2 x 3/4"	2643	13,2	150000
		142,5	49,8	27,1	4,1	37,5	11,4	50,7			5827	806	103321
LDG-40X-220Y-FC3-3	LDG-40X-220Y-FO3-3	3622	1267	688	105	953	290	1291	2 x 3/4"	2 x 3/4"	2660	16,0	150000
		142,6	49,9	27,1	4,1	37,5	11,4	50,8			5865	976	103321
LDG-40X-240Y-FC3-3	LDG-40X-240Y-FO3-3	3622	1267	688	105	953	290	1291	2 x 3/4"	2 x 3/4"	2686	19,0	150000
		142,6	49,9	27,1	4,1	37,5	11,4	50,8			5922	1159	103321
LDG-40X-260Y-FC3-3	LDG-40X-260Y-FO3-3	3808	1453	688	105	953	290	1477	2 x 3/4"	2 x 3/4"	2703	22,3	150000
		149,9	57,2	27,1	4,1	37,5	11,4	58,1			5959	1361	103321
LDG-40X-280Y-FC3-3	LDG-40X-280Y-FO3-3	3808	1453	688	105	953	290	1477	2 x 3/4"	2 x 3/4"	2720	25,8	150000
		149,9	57,2	27,1	4,1	37,5	11,4	58,1			5997	1574	103321
LDG-40X-300Y-FC3-3	LDG-40X-300Y-FO3-3	3813	1458	688	105	953	290	1482	2 x 3/4"	2 x 3/4"	2742	29,7	150000
		150,1	57,4	27,1	4,1	37,5	11,4	58,3			6045	1812	103321
LDG-40X-320Y-FC3-3	LDG-40X-320Y-FO3-3	3813	1458	688	105	953	290	1482	2 x 3/4"	2 x 3/4"	2759	33,8	150000
		150,1	57,4	27,1	4,1	37,5	11,4	58,3			6083	2063	103321
LDG-40X-340Y-FC3-3	LDG-40X-340Y-FO3-3	3813	1458	688	105	953	290	1482	2 x 3/4"	2 x 3/4"	2776	38,1	150000
		150,1	57,4	27,1	4,1	37,5	11,4	58,3			6121	2325	103321
LDG-40X-200Y-FC3-4	LDG-40X-200Y-FO3-4	3619	1264	688	105	953	290	1288	2 x 3/4"	2 x 3/4"	2643	13,2	150000
		142,5	49,8	27,1	4,1	37,5	11,4	50,7			5827	806	103321
LDG-40X-220Y-FC3-4	LDG-40X-220Y-FO3-4	3622	1267	688	105	953	290	1291	2 x 3/4"	2 x 3/4"	2660	16,0	150000
		142,6	49,9	27,1	4,1	37,5	11,4	50,8			5865	976	103321
LDG-40X-240Y-FC3-4	LDG-40X-240Y-FO3-4	3622	1267	688	105	953	290	1291	2 x 3/4"	2 x 3/4"	2686	19,0	150000
		142,6	49,9	27,1	4,1	37,5	11,4	50,8			5922	1159	103321
LDG-40X-260Y-FC3-4	LDG-40X-260Y-FO3-4	3808	1453	688	105	953	290	1477	2 x 3/4"	2 x 3/4"	2703	22,3	150000
		149,9	57,2	27,1	4,1	37,5	11,4	58,1			5959	1361	103321
LDG-40X-280Y-FC3-4	LDG-40X-280Y-FO3-4	3808	1453	688	105	953	290	1477	2 x 3/4"	2 x 3/4"	2720	25,8	150000
		149,9	57,2	27,1	4,1	37,5	11,4	58,1			5997	1574	103321
LDG-40X-300Y-FC3-4	LDG-40X-300Y-FO3-4	3813	1458	688	105	953	290	1482	2 x 3/4"	2 x 3/4"	2742	29,7	150000
		150,1	57,4	27,1	4,1	37,5	11,4	58,3			6045	1812	103321
LDG-40X-320Y-FC3-4	LDG-40X-320Y-FO3-4	3813	1458	688	105	953	290	1482	2 x 3/4"	2 x 3/4"	2759	33,8	150000
		150,1	57,4	27,1	4,1	37,5	11,4	58,3			6083	2063	103321
LDG-40X-340Y-FC3-4	LDG-40X-340Y-FO3-4	3813	1458	688	105	953	290	1482	2 x 3/4"	2 x 3/4"	2776	38,1	150000



Limitorque™ LDG Direct Gas Heavy-Duty Actuator Series FCD LFENTB0005-00-AQ - 06/16

LDG Single Acting - Dimensions: mm (in) - Weights: Kg (lbs) - Swept Volumes: l (cu in) - MOT: Nm (ft-lb)													
Model		a	b	c	d	e	f	g	"P" NPT PORT	"N" NPT PORT	Weight	Swept Volume*	MOT
LDG-40X-300Y-FC4-2	LDG-40X-300Y-FO4-2	4044	1458	700	110	953	290	1482	2 x 3/4"	2 x 3/4"	2248	29,7	150000
		159,2	57,4	27,5	4,3	37,5	11,4	58,3			4956	1812	103321
LDG-40X-320Y-FC4-2	LDG-40X-320Y-FO4-2	4044	1458	700	110	953	290	1482	2 x 3/4"	2 x 3/4"	2265	33,8	150000
		159,2	57,4	27,5	4,3	37,5	11,4	58,3			4994	2063	103321
LDG-40X-340Y-FC4-2	LDG-40X-340Y-FO4-2	4044	1458	700	110	953	290	1482	2 x 3/4"	2 x 3/4"	2282	38,1	150000
		159,2	57,4	27,5	4,3	37,5	11,4	58,3			5031	2325	103321
LDG-40X-220Y-FC4-3	LDG-40X-220Y-FO4-3	3853	1267	700	110	953	290	1291	2 x 3/4"	2 x 3/4"	2510	16,0	150000
		151,7	49,9	27,5	4,3	37,5	11,4	50,8			5534	976	103321
LDG-40X-240Y-FC4-3	LDG-40X-240Y-FO4-3	3853	1267	700	110	953	290	1291	2 x 3/4"	2 x 3/4"	2536	19,0	150000
		151,7	49,9	27,5	4,3	37,5	11,4	50,8			5591	1159	103321
LDG-40X-260Y-FC4-3	LDG-40X-260Y-FO4-3	4039	1453	700	110	953	290	1477	2 x 3/4"	2 x 3/4"	2553	22,3	150000
		159,0	57,2	27,5	4,3	37,5	11,4	58,1			5629	1361	103321
LDG-40X-280Y-FC4-3	LDG-40X-280Y-FO4-3	4039	1453	700	110	953	290	1477	2 x 3/4"	2 x 3/4"	2570	25,8	150000
		159,0	57,2	27,5	4,3	37,5	11,4	58,1			5666	1574	103321
LDG-40X-300Y-FC4-3	LDG-40X-300Y-FO4-3	4044	1458	700	110	953	290	1482	2 x 3/4"	2 x 3/4"	2592	29,7	150000
		159,2	57,4	27,5	4,3	37,5	11,4	58,3			5715	1812	103321
LDG-40X-320Y-FC4-3	LDG-40X-320Y-FO4-3	4044	1458	700	110	953	290	1482	2 x 3/4"	2 x 3/4"	2609	33,8	150000
		159,2	57,4	27,5	4,3	37,5	11,4	58,3			5752	2063	103321
LDG-40X-340Y-FC4-3	LDG-40X-340Y-FO4-3	4044	1458	700	110	953	290	1482	2 x 3/4"	2 x 3/4"	2626	38,1	150000
		159,2	57,4	27,5	4,3	37,5	11,4	58,3			5790	2325	103321
LDG-40X-240Y-FC4-4	LDG-40X-240Y-FO4-4	3853	1267	700	110	953	290	1291	2 x 3/4"	2 x 3/4"	2681	19,0	150000
		151,7	49,9	27,5	4,3	37,5	11,4	50,8			5911	1159	103321
LDG-40X-260Y-FC4-4	LDG-40X-260Y-FO4-4	4039	1453	700	110	953	290	1477	2 x 3/4"	2 x 3/4"	2698	22,3	150000
		159,0	57,2	27,5	4,3	37,5	11,4	58,1			5948	1361	103321
LDG-40X-280Y-FC4-4	LDG-40X-280Y-FO4-4	4039	1453	700	110	953	290	1477	2 x 3/4"	2 x 3/4"	2715	25,8	150000
		159,0	57,2	27,5	4,3	37,5	11,4	58,1			5986	1574	103321
LDG-40X-300Y-FC4-4	LDG-40X-300Y-FO4-4	4044	1458	700	110	953	290	1482	2 x 3/4"	2 x 3/4"	2737	29,7	150000
		159,2	57,4	27,5	4,3	37,5	11,4	58,3			6034	1812	103321
LDG-40X-320Y-FC4-4	LDG-40X-320Y-FO4-4	4044	1458	700	110	953	290	1482	2 x 3/4"	2 x 3/4"	2754	33,8	150000
		159,2	57,4	27,5	4,3	37,5	11,4	58,3			6072	2063	103321
LDG-40X-340Y-FC4-4	LDG-40X-340Y-FO4-4	4044	1458	700	110	953	290	1482	2 x 3/4"	2 x 3/4"	2771	38,1	150000
		159,2	57,4	27,5	4,3	37,5	11,4	58,3			6110	2325	103321
LDG-40X-240Y-FC5-1	LDG-40X-240Y-FO5-1	4540	1267	818	160	953	290	1291	2 x 3/4"	2 x 3/4"	3233	19,0	150000
		178,7	49,9	32,2	6,3	37,5	11,4	50,8			7128	1159	103321
LDG-40X-260Y-FC5-1	LDG-40X-260Y-FO5-1	4726	1453	818	160	953	290	1477	2 x 3/4"	2 x 3/4"	3250	22,3	150000
		186,1	57,2	32,2	6,3	37,5	11,4	58,1			7165	1361	103321
LDG-40X-280Y-FC5-1	LDG-40X-280Y-FO5-1	4726	1453	818	160	953	290	1477	2 x 3/4"	2 x 3/4"	3267	25,8	150000
		186,1	57,2	32,2	6,3	37,5	11,4	58,1			7203	1574	103321
LDG-40X-300Y-FC5-1	LDG-40X-300Y-FO5-1	4731	1458	818	160	953	290	1482	2 x 3/4"	2 x 3/4"	3289	29,7	150000
		186,3	57,4	32,2	6,3	37,5	11,4	58,3			7251	1812	103321
LDG-40X-320Y-FC5-1	LDG-40X-320Y-FO5-1	4731	1458	818	160	953	290	1482	2 x 3/4"	2 x 3/4"	3306	33,8	150000
		186,3	57,4	32,2	6,3	37,5	11,4	58,3			7289	2063	103321
LDG-40X-340Y-FC5-1	LDG-40X-340Y-FO5-1	4731	1458	818	160	953	290	1482	2 x 3/4"	2 x 3/4"	3323	38,1	150000
		186,3	57,4	32,2	6,3	37,5	11,4	58,3			7326	2325	103321
LDG-40X-260Y-FC5-2	LDG-40X-260Y-FO5-2	4726	1453	818	160	953	290	1477	2 x 3/4"	2 x 3/4"	3530	22,3	150000
		186,1	57,2	32,2	6,3	37,5	11,4	58,1			7783	1361	103321
LDG-40X-280Y-FC5-2	LDG-40X-280Y-FO5-2	4726	1453	818	160	953	290	1477	2 x 3/4"	2 x 3/4"	3547	25,8	150000
		186,1	57,2	32,2	6,3	37,5	11,4	58,1			7820	1574	103321
LDG-40X-300Y-FC5-2	LDG-40X-300Y-FO5-2	4731	1458	818	160	953	290	1482	2 x 3/4"	2 x 3/4"	3569	29,7	150000
		186,3	57,4	32,2	6,3	37,5	11,4	58,3			7869	1812	103321
LDG-40X-320Y-FC5-2	LDG-40X-320Y-FO5-2	4731	1458	818	160	953	290	1482	2 x 3/4"	2 x 3/4"	3586	33,8	150000
		186,3	57,4	32,2	6,3	37,5	11,4	58,3			7906	2063	103321
LDG-40X-340Y-FC5-2	LDG-40X-340Y-FO5-2	4731	1458	818	160	953	290	1482	2 x 3/4"	2 x 3/4"	3603	38,1	150000
		186,3	57,4	32,2	6,3	37,5	11,4	58,3			7944	2325	103321
LDG-40X-260Y-FC5-3	LDG-40X-260Y-FO5-3	4726	1453	818	160	953	290	1477	2 x 3/4"	2 x 3/4"	3900	22,3	150000
		186,1	57,2	32,2	6,3	37,5	11,4	58,1			8598	1361	103321
LDG-40X-280Y-FC5-3	LDG-40X-280Y-FO5-3	4726	1453	818	160	953	290	1477	2 x 3/4"	2 x 3/4"	3917	25,8	150000
		186,1	57,2	32,2	6,3	37,5	11,4	58,1			8636	1574	103321
LDG-40X-300Y-FC5-3	LDG-40X-300Y-FO5-3	4731	1458	818	160	953	290	1482	2 x 3/4"	2 x 3/4"	3939	29,7	150000
		186,3	57,4	32,2	6,3	37,5	11,4	58,3			8684	1812	103321
LDG-40X-320Y-FC5-3	LDG-40X-320Y-FO5-3	4731	1458	818	160	953	290	1482	2 x 3/4"	2 x 3/4"	3956	33,8	150000
		186,3	57,4	32,2	6,3	37,5	11,4	58,3			8722	2063	103321
LDG-40X-340Y-FC5-3	LDG-40X-340Y-FO5-3	4731	1458	818	160	953	290	1482	2 x 3/4"	2 x 3/4"	3973	38,1	150000
		186,3	57,4	32,2	6,3	37,5	11,4	58,3			8759	2325	103321
LDG-50X-220Y-FC1-1	LDG-50X-220Y-FO1-1	4973	1543	728	22	1150	343	1559	2 x 3/4"	2 x 3/4"	4504	19,5	300000
		195,8	60,7	28,6	0,8	45,3	13,5	61,4			9929	1190	221269
LDG-50X-240Y-FC1-1	LDG-50X-240Y-FO1-1	4978	1548	728	22	1150	343	1564	2 x 3/4"	2 x 3/4"	4552	23,3	300000
		196,0	60,9	28,6	0,8	45,3	13,5	61,6			10035	1422	221269
LDG-50X-260Y-FC1-1	LDG-50X-260Y-FO1-1	4983	1553	728	22	1150	343	1569	2 x 3/4"	2 x 3/4"	4587	27,3	300000
		196,2	61,1	28,6	0,8	45,3	13,5	61,8			10112	1666	221269
LDG-50X-280Y-FC1-1	LDG-50X-280Y-FO1-1	4983	1553	728	22	1150	343	1569	2 x 3/4"	2 x 3/4"	4621	31,7	300000
		196,2	61,1	28,6	0,8	45,3	13,5	61,8			10188	1934	221269
LDG-50X-300Y-FC1-1	LDG-50X-300Y-FO1-1	5226	1796	728	22	1150	343	1812	2 x 3/4"	2 x 3/4"	4656	36,3	300000
		205,7	70,7	28,6	0,8	45,3	13,5	71,3			10265	2215	221269
LDG-50X-320Y-FC1-1	LDG-50X-320Y-FO1-1	5226	1796	728	22	1150	343	1812	2 x 3/4"	2 x 3/4"	4691	41,4	300000
		205,7	70,7	28,6	0,8	45,3	13,5	71,3			10342	2526	221269
LDG-50X-340Y-FC1-1	LDG-50X-340Y-FO1-1	5231	1801	728	22	1150	343	1817	2 x 3/4"	2 x 3/4"	4726	46,7	300000
		205,9	70,9	28,6	0,8	45,3	13,5	71,5			10419	2850	221269
LDG-50X-360Y-FC1-1	LDG-50X-360Y-FO1-1	5231	1801	728	22	1150	343	1817	2 x 3/4"	2 x 3/4"	4761	52,3	300000
		205,9	70,9	28,6	0,8	45,3	13,5	71,5			10496	3192	221269
LDG-50X-380Y-FC1-1	LDG-50X-380Y-FO1-1	5236	1806	728	22	1150	343	1822	2 x 3/4"	2 x 3/4"	4796	58,3	300000
		206,1	71,1	28,6	0,8	45,3	13,5	71,7			10572	3558	221269
LDG-													



Limitorque™ LDG Direct Gas Heavy-Duty Actuator Series FCD LFENTB0005-00-AQ - 06/16

LDG Single Acting - Dimensions: mm (in) - Weights: Kg (lbs) - Swept Volumes: l (cu in) - MOT: Nm (ft-lb)												
Model	a	b	c	d	e	f	g	"P" NPT PORT	"N" NPT PORT	Weight	Swept Volume*	MOT
LDG-50X-260Y-FC1-4	4983	1553	728	22	1150	343	1569	2 x 3/4"	2 x 3/4"	5095	27,3	300000
	196,2	61,1	28,6	0,8	45,3	13,5	61,8			11232	1666	221269
LDG-50X-280Y-FC1-4	4983	1553	728	22	1150	343	1569	2 x 3/4"	2 x 3/4"	5129	31,7	300000
	196,2	61,1	28,6	0,8	45,3	13,5	61,8			11308	1934	221269
LDG-50X-300Y-FC1-4	5226	1796	728	22	1150	343	1812	2 x 3/4"	2 x 3/4"	5164	36,3	300000
	205,7	70,7	28,6	0,8	45,3	13,5	71,3			11385	2215	221269
LDG-50X-320Y-FC1-4	5226	1796	728	22	1150	343	1812	2 x 3/4"	2 x 3/4"	5199	41,4	300000
	205,7	70,7	28,6	0,8	45,3	13,5	71,3			11462	2526	221269
LDG-50X-340Y-FC1-4	5231	1801	728	22	1150	343	1817	2 x 3/4"	2 x 3/4"	5234	46,7	300000
	205,9	70,9	28,6	0,8	45,3	13,5	71,5			11539	2850	221269
LDG-50X-360Y-FC1-4	5231	1801	728	22	1150	343	1817	2 x 3/4"	2 x 3/4"	5269	52,3	300000
	205,9	70,9	28,6	0,8	45,3	13,5	71,5			11616	3192	221269
LDG-50X-380Y-FC1-4	5236	1806	728	22	1150	343	1822	2 x 3/4"	2 x 3/4"	5304	58,3	300000
	206,1	71,1	28,6	0,8	45,3	13,5	71,7			11692	3558	221269
LDG-50X-400Y-FC1-4	5236	1806	728	22	1150	343	1822	2 x 3/4"	2 x 3/4"	5343	64,6	300000
	206,1	71,1	28,6	0,8	45,3	13,5	71,7			11780	3942	221269
LDG-50X-240Y-FC2-1	5027	1548	818	67	1150	343	1564	2 x 3/4"	2 x 3/4"	4919	23,3	300000
	197,9	60,9	32,2	2,6	45,3	13,5	61,6			10844	1422	221269
LDG-50X-260Y-FC2-1	5032	1553	818	67	1150	343	1569	2 x 3/4"	2 x 3/4"	4954	27,3	300000
	198,1	61,1	32,2	2,6	45,3	13,5	61,8			10921	1666	221269
LDG-50X-280Y-FC2-1	5032	1553	818	67	1150	343	1569	2 x 3/4"	2 x 3/4"	4988	31,7	300000
	198,1	61,1	32,2	2,6	45,3	13,5	61,8			10998	1934	221269
LDG-50X-300Y-FC2-1	5275	1796	818	67	1150	343	1812	2 x 3/4"	2 x 3/4"	5023	36,3	300000
	207,7	70,7	32,2	2,6	45,3	13,5	71,3			11074	2215	221269
LDG-50X-320Y-FC2-1	5275	1796	818	67	1150	343	1812	2 x 3/4"	2 x 3/4"	5058	41,4	300000
	207,7	70,7	32,2	2,6	45,3	13,5	71,3			11151	2526	221269
LDG-50X-340Y-FC2-1	5280	1801	818	67	1150	343	1817	2 x 3/4"	2 x 3/4"	5093	46,7	300000
	207,9	70,9	32,2	2,6	45,3	13,5	71,5			11228	2850	221269
LDG-50X-360Y-FC2-1	5280	1801	818	67	1150	343	1817	2 x 3/4"	2 x 3/4"	5128	52,3	300000
	207,9	70,9	32,2	2,6	45,3	13,5	71,5			11305	3192	221269
LDG-50X-380Y-FC2-1	5285	1806	818	67	1150	343	1822	2 x 3/4"	2 x 3/4"	5163	58,3	300000
	208,1	71,1	32,2	2,6	45,3	13,5	71,7			11382	3558	221269
LDG-50X-400Y-FC2-1	5285	1806	818	67	1150	343	1822	2 x 3/4"	2 x 3/4"	5202	64,6	300000
	208,1	71,1	32,2	2,6	45,3	13,5	71,7			11469	3942	221269
LDG-50X-280Y-FC2-2	5032	1553	818	67	1150	343	1569	2 x 3/4"	2 x 3/4"	5440	31,7	300000
	198,1	61,1	32,2	2,6	45,3	13,5	61,8			11994	1934	221269
LDG-50X-300Y-FC2-2	5275	1796	818	67	1150	343	1812	2 x 3/4"	2 x 3/4"	5475	36,3	300000
	207,7	70,7	32,2	2,6	45,3	13,5	71,3			12071	2215	221269
LDG-50X-320Y-FC2-2	5275	1796	818	67	1150	343	1812	2 x 3/4"	2 x 3/4"	5510	41,4	300000
	207,7	70,7	32,2	2,6	45,3	13,5	71,3			12148	2526	221269
LDG-50X-340Y-FC2-2	5280	1801	818	67	1150	343	1817	2 x 3/4"	2 x 3/4"	5545	46,7	300000
	207,9	70,9	32,2	2,6	45,3	13,5	71,5			12224	2850	221269
LDG-50X-360Y-FC2-2	5280	1801	818	67	1150	343	1817	2 x 3/4"	2 x 3/4"	5580	52,3	300000
	207,9	70,9	32,2	2,6	45,3	13,5	71,5			12301	3192	221269
LDG-50X-380Y-FC2-2	5285	1806	818	67	1150	343	1822	2 x 3/4"	2 x 3/4"	5615	58,3	300000
	208,1	71,1	32,2	2,6	45,3	13,5	71,7			12378	3558	221269
LDG-50X-400Y-FC2-2	5285	1806	818	67	1150	343	1822	2 x 3/4"	2 x 3/4"	5654	64,6	300000
	208,1	71,1	32,2	2,6	45,3	13,5	71,7			12466	3942	221269
LDG-50X-280Y-FC3-1	5072	1553	896	106	1150	343	1569	2 x 3/4"	2 x 3/4"	5553	31,7	300000
	199,7	61,1	35,3	4,2	45,3	13,5	61,8			12243	1934	221269
LDG-50X-300Y-FC3-1	5315	1796	896	106	1150	343	1812	2 x 3/4"	2 x 3/4"	5588	36,3	300000
	209,3	70,7	35,3	4,2	45,3	13,5	71,3			12320	2215	221269
LDG-50X-320Y-FC3-1	5315	1796	896	106	1150	343	1812	2 x 3/4"	2 x 3/4"	5623	41,4	300000
	209,3	70,7	35,3	4,2	45,3	13,5	71,3			12397	2526	221269
LDG-50X-340Y-FC3-1	5320	1801	896	106	1150	343	1817	2 x 3/4"	2 x 3/4"	5658	46,7	300000
	209,4	70,9	35,3	4,2	45,3	13,5	71,5			12474	2850	221269
LDG-50X-360Y-FC3-1	5320	1801	896	106	1150	343	1817	2 x 3/4"	2 x 3/4"	5693	52,3	300000
	209,4	70,9	35,3	4,2	45,3	13,5	71,5			12550	3192	221269
LDG-50X-380Y-FC3-1	5325	1806	896	106	1150	343	1822	2 x 3/4"	2 x 3/4"	5728	58,3	300000
	209,6	71,1	35,3	4,2	45,3	13,5	71,7			12627	3558	221269
LDG-50X-400Y-FC3-1	5325	1806	896	106	1150	343	1822	2 x 3/4"	2 x 3/4"	5767	64,6	300000
	209,6	71,1	35,3	4,2	45,3	13,5	71,7			12715	3942	221269
LDG-50X-320Y-FC3-2	5315	1796	896	106	1150	343	1812	2 x 3/4"	2 x 3/4"	6159	41,4	300000
	209,3	70,7	35,3	4,2	45,3	13,5	71,3			13578	2526	221269
LDG-50X-340Y-FC3-2	5320	1801	896	106	1150	343	1817	2 x 3/4"	2 x 3/4"	6194	46,7	300000
	209,4	70,9	35,3	4,2	45,3	13,5	71,5			13655	2850	221269
LDG-50X-360Y-FC3-2	5320	1801	896	106	1150	343	1817	2 x 3/4"	2 x 3/4"	6229	52,3	300000
	209,4	70,9	35,3	4,2	45,3	13,5	71,5			13732	3192	221269
LDG-50X-380Y-FC3-2	5325	1806	896	106	1150	343	1822	2 x 3/4"	2 x 3/4"	6264	58,3	300000
	209,6	71,1	35,3	4,2	45,3	13,5	71,7			13809	3558	221269
LDG-50X-400Y-FC3-2	5325	1806	896	106	1150	343	1822	2 x 3/4"	2 x 3/4"	6303	64,6	300000
	209,6	71,1	35,3	4,2	45,3	13,5	71,7			13897	3942	221269
LDG-50X-320Y-FC3-3	5315	1796	896	106	1150	343	1812	2 x 3/4"	2 x 3/4"	6415	41,4	300000
	209,3	70,7	35,3	4,2	45,3	13,5	71,3			14143	2526	221269
LDG-50X-340Y-FC3-3	5320	1801	896	106	1150	343	1817	2 x 3/4"	2 x 3/4"	6450	46,7	300000
	209,4	70,9	35,3	4,2	45,3	13,5	71,5			14220	2850	221269
LDG-50X-360Y-FC3-3	5320	1801	896	106	1150	343	1817	2 x 3/4"	2 x 3/4"	6485	52,3	300000
	209,4	70,9	35,3	4,2	45,3	13,5	71,5			14296	3192	221269
LDG-50X-380Y-FC3-3	5325	1806	896	106	1150	343	1822	2 x 3/4"	2 x 3/4"	6520	58,3	300000
	209,6	71,1	35,3	4,2	45,3	13,5	71,7			14373	3558	221269
LDG-50X-400Y-FC3-3	5325	1806	896	106	1150	343	1822	2 x 3/4"	2 x 3/4"	6559	64,6	300000
	209,6	71,1	35,3	4,2	45,3	13,5	71,7			14461	3942	221269

* Swept Volume data are referred to actuators with end stops adjusted for 90° of stroke.

LDG Double Acting: Dimensional, Weight and Volume Tables

Figure 10: Dimensional Data – Double Acting

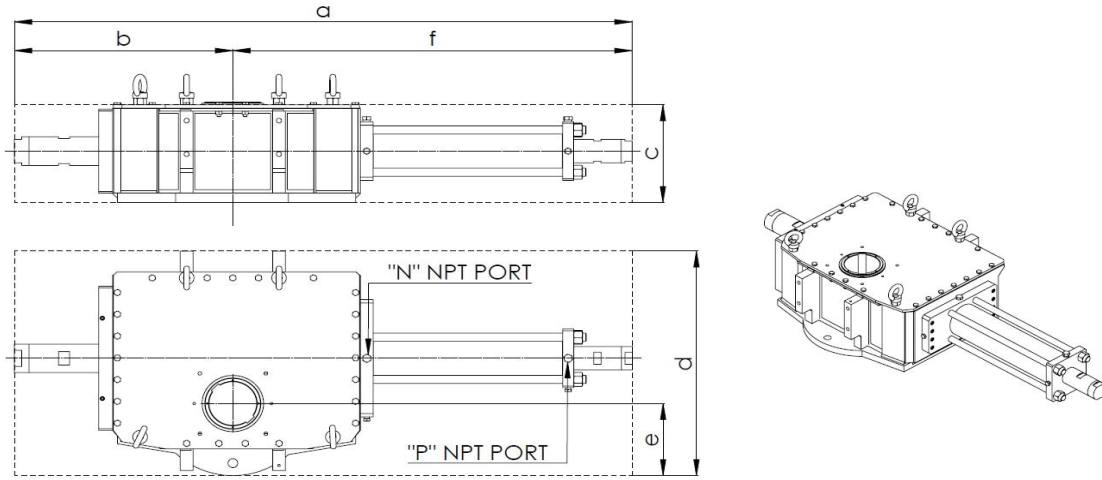

LDG Double Acting - Dimensions: mm (in) - Weights: Kg (lbs) - Swept Volumes: l (cu in) - MOT: Nm (ft-lb)												
Model	a	b	c	d	e	f	"P" NPT PORT	"N" NPT PORT	Weight	Swept Volume*		MOT
										"P" PORT	"N" PORT	
LDG-15X-050Y-D1	736	256	183	352	120	480	2 x 1/2"	2 x 1/2"	79	0,3	0,2	6000
	29,0	10,1	7,2	13,9	4,7	18,9			173	18	14	4425
LDG-15X-060Y-D1	736	256	183	352	120	480	2 x 1/2"	2 x 1/2"	81	0,4	0,3	6000
	29,0	10,1	7,2	13,9	4,7	18,9			179	24	21	4425
LDG-15X-070Y-D1	736	256	183	352	120	480	2 x 1/2"	2 x 1/2"	84	0,5	0,4	6000
	29,0	10,1	7,2	13,9	4,7	18,9			184	31	27	4425
LDG-15X-080Y-D1	736	256	183	352	120	480	2 x 1/2"	2 x 1/2"	86	0,7	0,6	6000
	29,0	10,1	7,2	13,9	4,7	18,9			190	43	39	4425
LDG-15X-090Y-D1	736	256	183	352	120	480	2 x 1/2"	2 x 1/2"	93	0,9	0,8	6000
	29,0	10,1	7,2	13,9	4,7	18,9			204	55	51	4425
LDG-15X-100Y-D1	736	256	183	352	120	480	2 x 1/2"	2 x 1/2"	95	1,1	1,0	6000
	29,0	10,1	7,2	13,9	4,7	18,9			209	67	63	4425
LDG-15X-110Y-D1	769	256	183	352	120	513	2 x 1/2"	2 x 1/2"	98	1,3	1,2	6000
	30,3	10,1	7,2	13,9	4,7	20,2			215	79	74	4425
LDG-15X-120Y-D1	774	256	183	352	120	518	2 x 1/2"	2 x 1/2"	100	1,5	1,4	6000
	30,5	10,1	7,2	13,9	4,7	20,4			220	92	86	4425
LDG-20X-060Y-D1	905	323	195	444	150	582	2 x 1/2"	2 x 1/2"	126	0,5	0,4	12000
	35,6	12,7	7,7	17,5	5,9	22,9			277	31	25	8851
LDG-20X-070Y-D1	905	323	195	444	150	582	2 x 1/2"	2 x 1/2"	128	0,7	0,6	12000
	35,6	12,7	7,7	17,5	5,9	22,9			283	43	38	8851
LDG-20X-080Y-D1	905	323	195	444	150	582	2 x 1/2"	2 x 1/2"	131	0,9	0,8	12000
	35,6	12,7	7,7	17,5	5,9	22,9			289	55	50	8851
LDG-20X-090Y-D1	905	323	195	444	150	582	2 x 1/2"	2 x 1/2"	138	1,1	1,0	12000
	35,6	12,7	7,7	17,5	5,9	22,9			304	67	62	8851
LDG-20X-100Y-D1	905	323	195	444	150	582	2 x 1/2"	2 x 1/2"	140	1,4	1,3	12000
	35,6	12,7	7,7	17,5	5,9	22,9			309	85	80	8851
LDG-20X-110Y-D1	905	323	195	444	150	582	2 x 1/2"	2 x 1/2"	143	1,7	1,6	12000
	35,6	12,7	7,7	17,5	5,9	22,9			315	104	99	8851
LDG-20X-120Y-D1	953	323	195	444	150	630	2 x 1/2"	2 x 1/2"	146	2,0	1,8	12000
	37,5	12,7	7,7	17,5	5,9	24,8			321	122	112	8851
LDG-20X-140Y-D1	953	323	195	444	150	630	2 x 1/2"	2 x 1/2"	151	2,7	2,5	12000
	37,5	12,7	7,7	17,5	5,9	24,8			333	165	155	8851
LDG-25X-070Y-D1	1064	365	221	534	188	699	2 x 1/2"	2 x 1/2"	191	0,8	0,7	21000
	41,9	14,4	8,7	21,0	7,4	27,5			421	49	40	15489
LDG-25X-080Y-D1	1064	365	221	534	188	699	2 x 1/2"	2 x 1/2"	195	1,1	1,0	21000
	41,9	14,4	8,7	21,0	7,4	27,5			430	67	58	15489
LDG-25X-090Y-D1	1064	365	221	534	188	699	2 x 1/2"	2 x 1/2"	203	1,4	1,3	21000
	41,9	14,4	8,7	21,0	7,4	27,5			448	85	76	15489
LDG-25X-100Y-D1	1064	365	221	534	188	699	2 x 1/2"	2 x 1/2"	207	1,7	1,6	21000
	41,9	14,4	8,7	21,0	7,4	27,5			457	104	95	15489
LDG-25X-110Y-D1	1064	365	221	534	188	699	2 x 1/2"	2 x 1/2"	212	2,1	2,0	21000
	41,9	14,4	8,7	21,0	7,4	27,5			466	128	119	15489
LDG-25X-120Y-D1	1069	365	221	534	188	704	2 x 1/2"	2 x 1/2"	216	2,5	2,4	21000
	42,1	14,4	8,7	21,0	7,4	27,7			475	153	144	15489
LDG-25X-140Y-D1	1069	365	221	534	188	704	2 x 1/2"	2 x 1/2"	224	3,4	3,3	21000
	42,1	14,4	8,7	21,0	7,4	27,7			494	207	198	15489
LDG-25X-160Y-D1	1120	365	221	534	188	755	2 x 1/2"	2 x 1/2"	232	4,4	4,1	21000
	44,1	14,4	8,7	21,0	7,4	29,7			512	269	252	15489
LDG-25X-180Y-D1	1125	365	232	534	188	760	2 x 3/4"	2 x 3/4"	241	5,6	5,3	21000
	44,3	14,4	9,1	21,0	7,4	29,9			531	342	326	15489
LDG-30X-080Y-D1	1310	458	292	670	215	852	2 x 1/2"	2 x 1/2"	375	1,4	1,1	40500
	51,6	18,0	11,5	26,4	8,5	33,5			827	85	65	29871
LDG-30X-090Y-D1	1310	458	292	670	215	852	2 x 1/2"	2 x 1/2"	385	1,8	1,5	40500
	51,6	18,0	11,5	26,4	8,5	33,5			849	110	89	29871
LDG-30X-100Y-D1	1315	458	292	670	215	857	2 x 1/2"	2 x 1/2"	391	2,2	1,9	40500
	51,8	18,0	11,5	26,4	8,5	33,7			862	134	114	29871
LDG-30X-110Y-D1	1320	458	292	670	215	862	2 x 1/2"	2 x 1/2"	397	2,7	2,4	40500
	52,0	18,0	11,5	26,4	8,5	33,9			875	165	144	29871



Limitorque™ LDG Direct Gas Heavy-Duty Actuator Series FCD LFENTB0005-00-AQ - 06/16

LDG Double Acting - Dimensions: mm (in) - Weights: Kg (lbs) - Swept Volumes: l (cu in) - MOT: Nm (ft-lb)												
Model	a	b	c	d	e	f	"P" NPT PORT	"N" NPT PORT	Weight	Swept Volume*		MOT
										"P" PORT	"N" PORT	
LDG-30X-120Y-D1	1325	458	292	670	215	867	2 x 1/2"	2 x 1/2"	403	3,2	2,9	40500
	52,2	18,0	11,5	26,4	8,5	34,1			888	195	175	29871
LDG-30X-140Y-D1	1330	458	292	670	215	872	2 x 1/2"	2 x 1/2"	415	4,4	4,1	40500
	52,4	18,0	11,5	26,4	8,5	34,3			915	269	248	29871
LDG-30X-160Y-D1	1335	458	292	670	215	877	2 x 1/2"	2 x 1/2"	427	5,7	5,4	40500
	52,6	18,0	11,5	26,4	8,5	34,5			941	348	327	29871
LDG-30X-180Y-D1	1340	458	292	670	215	882	2 x 3/4"	2 x 3/4"	439	7,2	6,9	40500
	52,7	18,0	11,5	26,4	8,5	34,7			968	439	419	29871
LDG-30X-200Y-D1	1414	458	292	670	215	956	2 x 3/4"	2 x 3/4"	459	8,9	8,4	40500
	55,6	18,0	11,5	26,4	8,5	37,6			1012	543	511	29871
LDG-30X-220Y-D1	1424	458	298	670	215	966	2 x 3/4"	2 x 3/4"	471	10,8	10,3	40500
	56,1	18,0	11,7	26,4	8,5	38,0			1038	659	627	29871
LDG-35X-100Y-D1	1619	570	358	849	260	1049	2 x 1/2"	2 x 1/2"	741	2,7	1,9	75000
	63,7	22,4	14,1	33,4	10,2	41,3			1633	165	117	51661
LDG-35X-110Y-D1	1624	570	358	849	260	1054	2 x 1/2"	2 x 1/2"	748	3,3	2,5	75000
	63,9	22,4	14,1	33,4	10,2	41,5			1649	201	154	51661
LDG-35X-120Y-D1	1629	570	358	849	260	1059	2 x 1/2"	2 x 1/2"	755	3,9	3,1	75000
	64,1	22,4	14,1	33,4	10,2	41,7			1665	238	190	51661
LDG-35X-140Y-D1	1634	570	358	849	260	1064	2 x 1/2"	2 x 1/2"	770	5,3	4,5	75000
	64,3	22,4	14,1	33,4	10,2	41,9			1697	323	276	51661
LDG-35X-160Y-D1	1639	570	358	849	260	1069	2 x 1/2"	2 x 1/2"	784	7,0	6,2	75000
	64,5	22,4	14,1	33,4	10,2	42,1			1729	427	379	51661
LDG-35X-180Y-D1	1644	570	358	849	260	1074	2 x 3/4"	2 x 3/4"	799	8,8	8,0	75000
	64,7	22,4	14,1	33,4	10,2	42,3			1761	537	489	51661
LDG-35X-200Y-D1	1647	570	358	849	260	1077	2 x 3/4"	2 x 3/4"	821	10,9	10,1	75000
	64,8	22,4	14,1	33,4	10,2	42,4			1810	665	617	51661
LDG-35X-220Y-D1	1759	570	358	849	260	1189	2 x 3/4"	2 x 3/4"	835	13,2	12,1	75000
	69,3	22,4	14,1	33,4	10,2	46,8			1842	806	739	51661
LDG-35X-240Y-D1	1759	570	358	849	260	1189	2 x 3/4"	2 x 3/4"	868	15,7	14,6	75000
	69,3	22,4	14,1	33,4	10,2	46,8			1913	958	891	51661
LDG-35X-260Y-D1	1764	570	358	849	260	1194	2 x 3/4"	2 x 3/4"	882	18,4	17,3	75000
	69,4	22,4	14,1	33,4	10,2	47,0			1945	1123	1056	51661
LDG-35X-280Y-D1	1764	570	425	849	260	1194	2 x 3/4"	2 x 3/4"	897	21,3	20,2	75000
	69,4	22,4	16,7	33,4	10,2	47,0			1977	1300	1233	51661
LDG-40X-120Y-D1	1993	708	399	953	290	1285	2 x 1/2"	2 x 1/2"	1171	4,7	3,4	150000
	78,4	27,9	15,7	37,5	11,4	50,6			2582	287	206	103321
LDG-40X-140Y-D1	1996	708	399	953	290	1288	2 x 1/2"	2 x 1/2"	1188	6,5	5,2	150000
	78,6	27,9	15,7	37,5	11,4	50,7			2619	397	316	103321
LDG-40X-160Y-D1	1996	708	399	953	290	1288	2 x 1/2"	2 x 1/2"	1205	8,4	7,1	150000
	78,6	27,9	15,7	37,5	11,4	50,7			2657	513	432	103321
LDG-40X-180Y-D1	1996	708	399	953	290	1288	2 x 3/4"	2 x 3/4"	1222	10,7	9,4	150000
	78,6	27,9	15,7	37,5	11,4	50,7			2694	653	572	103321
LDG-40X-200Y-D1	1996	708	399	953	290	1288	2 x 3/4"	2 x 3/4"	1247	13,2	11,9	150000
	78,6	27,9	15,7	37,5	11,4	50,7			2749	806	725	103321
LDG-40X-220Y-D1	1999	708	399	953	290	1291	2 x 3/4"	2 x 3/4"	1264	16,0	14,7	150000
	78,7	27,9	15,7	37,5	11,4	50,8			2787	976	895	103321
LDG-40X-240Y-D1	1999	708	399	953	290	1291	2 x 3/4"	2 x 3/4"	1299	19,0	17,7	150000
	78,7	27,9	15,7	37,5	11,4	50,8			2864	1159	1078	103321
LDG-40X-260Y-D1	2185	708	399	953	290	1477	2 x 3/4"	2 x 3/4"	1316	22,3	20,3	150000
	86,0	27,9	15,7	37,5	11,4	58,1			2902	1361	1238	103321
LDG-40X-280Y-D1	2185	708	425	953	290	1477	2 x 3/4"	2 x 3/4"	1333	25,8	23,8	150000
	86,0	27,9	16,7	37,5	11,4	58,1			2939	1574	1452	103321
LDG-40X-300Y-D1	2190	708	445	953	290	1482	2 x 3/4"	2 x 3/4"	1360	29,7	27,7	150000
	86,2	27,9	17,5	37,5	11,4	58,3			2999	1812	1690	103321
LDG-40X-320Y-D1	2190	708	455	953	290	1482	2 x 3/4"	2 x 3/4"	1377	33,8	31,8	150000
	86,2	27,9	17,9	37,5	11,4	58,3			3036	2063	1940	103321
LDG-40X-340Y-D1	2190	708	465	953	290	1482	2 x 3/4"	2 x 3/4"	1394	38,1	36,1	150000
	86,2	27,9	18,3	37,5	11,4	58,3			3074	2325	2202	103321
LDG-50X-140Y-D1	2417	883	582	1150	343	1534	2 x 1/2"	2 x 1/2"	2478	7,9	5,7	300000
	95,1	34,7	22,9	45,3	13,5	60,4			5462	482	350	221269
LDG-50X-160Y-D1	2422	883	582	1150	343	1539	2 x 1/2"	2 x 1/2"	2512	10,3	8,1	300000
	95,3	34,7	22,9	45,3	13,5	60,6			5539	629	496	221269
LDG-50X-180Y-D1	2427	883	582	1150	343	1544	2 x 3/4"	2 x 3/4"	2547	13,1	10,9	300000
	95,5	34,7	22,9	45,3	13,5	60,8			5616	799	667	221269
LDG-50X-200Y-D1	2432	883	582	1150	343	1549	2 x 3/4"	2 x 3/4"	2590	16,2	14,0	300000
	95,7	34,7	22,9	45,3	13,5	61,0			5710	989	856	221269
LDG-50X-220Y-D1	2442	883	582	1150	343	1559	2 x 3/4"	2 x 3/4"	2625	19,5	17,3	300000
	96,1	34,7	22,9	45,3	13,5	61,4			5787	1190	1058	221269
LDG-50X-240Y-D1	2447	883	582	1150	343	1564	2 x 3/4"	2 x 3/4"	2686	23,3	21,1	300000
	96,3	34,7	22,9	45,3	13,5	61,6			5921	1422	1290	221269
LDG-50X-260Y-D1	2452	883	582	1150	343	1569	2 x 3/4"	2 x 3/4"	2721	27,3	25,1	300000
	96,5	34,7	22,9	45,3	13,5	61,8			5998	1666	1534	221269
LDG-50X-280Y-D1	2452	883	582	1150	343	1569	2 x 3/4"	2 x 3/4"	2755	31,7	29,5	300000
	96,5	34,7	22,9	45,3	13,5	61,8			6075	1934	1802	221269
LDG-50X-300Y-D1	2695	883	582	1150	343	1812	2 x 3/4"	2 x 3/4"	2790	36,3	32,5	300000
	106,1	34,7	22,9	45,3	13,5	71,3			6151	2215	1980	221269
LDG-50X-320Y-D1	2695	883	582	1150	343	1812	2 x 3/4"	2 x 3/4"	2825	41,4	37,6	300000
	106,1	34,7	22,9	45,3	13,5	71,3			6228	2526	2292	221269
LDG-50X-340Y-D1	2700	883	582	1150	343	1817	2 x 3/4"	2 x 3/4"	2860	46,7	42,9	300000
	106,3	34,7	22,9	45,3	13,5	71,5			6305	2850	2615	221269
LDG-50X-360Y-D1	2700	883	582	1150	343	1817	2 x 3/4"	2 x 3/4"	2895	52,3	48,5	300000
	106,3	34,7	22,9	45,3	13,5	71,5			6382	3192	2957	221269
LDG-50X-380Y-D1	2705	883	582	1150	343	1822	2 x 3/4"	2 x 3/4"	2930	58,3	54,5	300000
	106,5	34,7	22,9	45,3	13,5	71,7			6459	3558	3323	221269
LDG-50X-400Y-D1	2705	883	582	1150	343	1822	2 x 3/4"	2 x 3/4"	2974	64,6	60,8	300000
	106,5	34,7	22,9	45,3	13,5	71,7			6557	3942	3707	221269

* Swept Volume data are referred to actuators with end stops adjusted for 90° of stroke.

MHPC - Dimensions: mm (in) - Weights: Kg (lbs)

Single Acting - Fail Close (Fc) Configuration

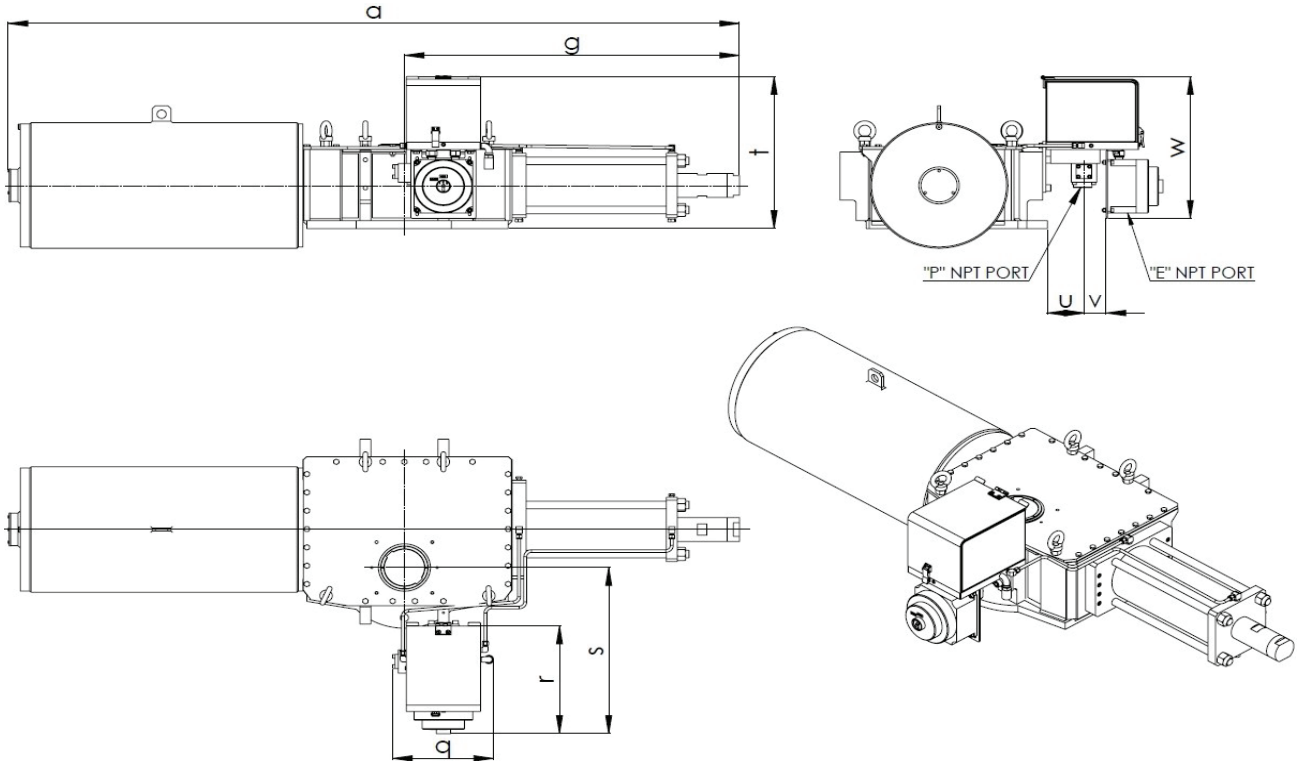

Model	a*	g*	q	r	s	t	u	v	w	MHPC "P" NPT PORT**	"E" NPT PORT	MHPC WEIGHT
LDG-15			326	382	502	340	127	72	503	1/2"	3/4"	40
			12,8	15,0	19,8	13,4	5,0	2,8	19,8			88
LDG-20			326	382	524	356	119	72	503	1/2"	3/4"	40
			12,8	15,0	20,6	14,0	4,7	2,8	19,8			88
LDG-25			326	382	568	355	125	72	503	1/2"	3/4"	40
			12,8	15,0	22,4	14,0	4,9	2,8	19,8			88
LDG-30			326	382	589	386	119	72	503	1/2"	3/4"	40
			12,8	15,0	23,2	15,2	4,7	2,8	19,8			88
LDG-35			326	382	658	409	153	72	503	1/2"	3/4"	40
			12,8	15,0	25,9	16,1	6,0	2,8	19,8			88
LDG-40			326	382	674	426	149	72	503	1/2"	3/4"	40
			12,8	15,0	26,5	16,8	5,8	2,8	19,8			88
LDG-50			326	382	758	463	160	72	503	1/2"	3/4"	40
			12,8	15,0	29,8	18,2	6,3	2,8	19,8			88

(*) Note: for this measure see LDG DIMENSIONAL - WEIGHT - VOLUME TABLES.

(**) This measure can be 1 or 2 x "P" NPT PORT upon request.

Single Acting - Fail Open (Fc) Configuration

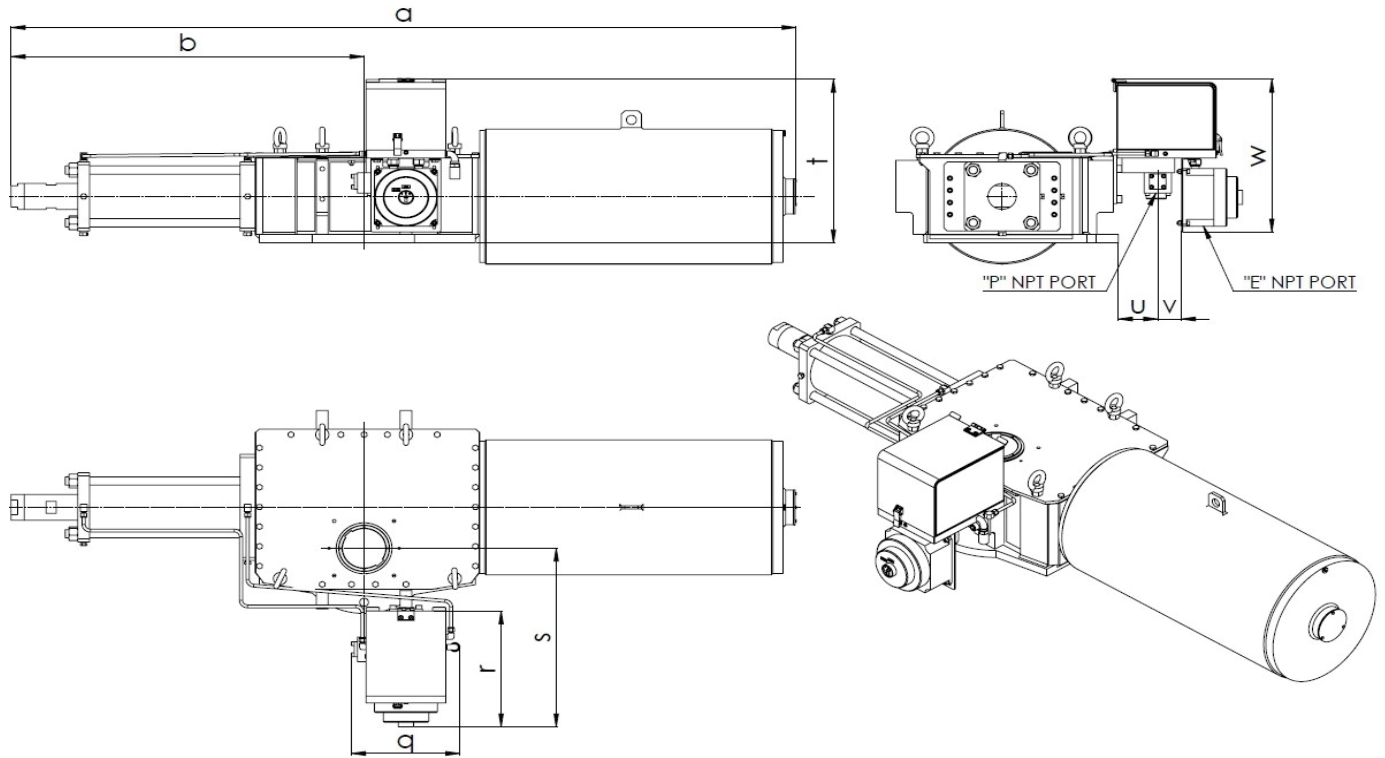

Model	a*	b*	q	r	s	t	u	v	w	MHPC "P" NPT PORT**	"E" NPT PORT	MHPC WEIGHT
LDG-15			326	382	502	340	127	72	503	½"	¾"	40
			12,8	15,0	19,8	13,4	5,0	2,8	19,8			88
LDG-20			326	382	524	356	119	72	503	½"	¾"	40
			12,8	15,0	20,6	14,0	4,7	2,8	19,8			88
LDG-25			326	382	568	355	125	72	503	½"	¾"	40
			12,8	15,0	22,4	14,0	4,9	2,8	19,8			88
LDG-30			326	382	589	386	119	72	503	½"	¾"	40
			12,8	15,0	23,2	15,2	4,7	2,8	19,8			88
LDG-35			326	382	658	409	153	72	503	½"	¾"	40
			12,8	15,0	25,9	16,1	6,0	2,8	19,8			88
LDG-40			326	382	674	426	149	72	503	½"	¾"	40
			12,8	15,0	26,5	16,8	5,8	2,8	19,8			88
LDG-50			326	382	758	463	160	72	503	½"	¾"	40
			12,8	15,0	29,8	18,2	6,3	2,8	19,8			88

(*) Note: for this measure see LDG DIMENSIONAL - WEIGHT - VOLUME TABLES.

(**) This measure can be 1 or 2 x "P" NPT PORT upon request.

Double Acting

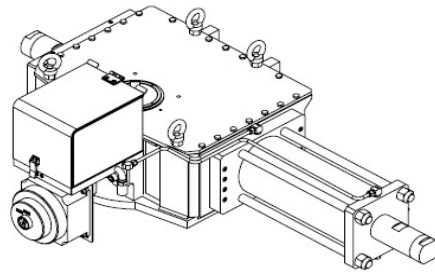
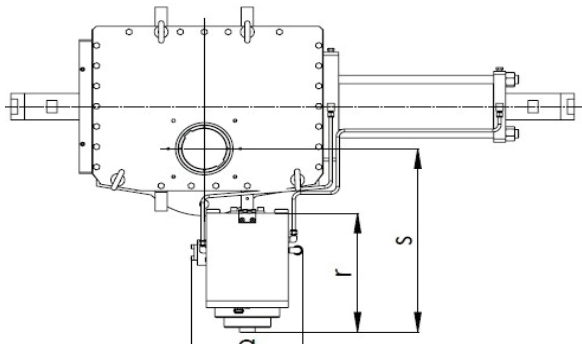
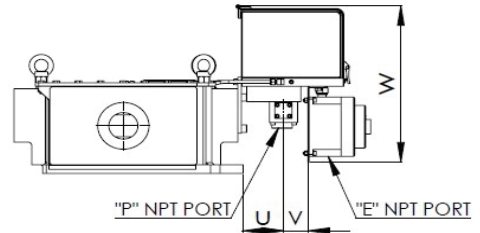
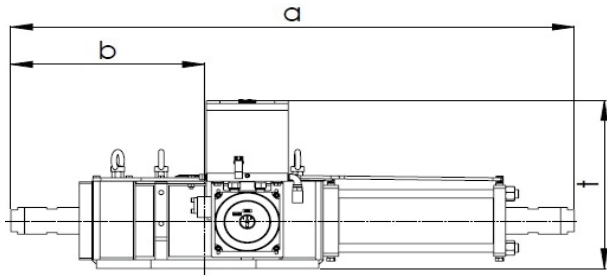

Model	a*	b*	q	r	s	t	u	v	w	MHPC "P" NPT PORT**	"E" NPT PORT	MHPC WEIGHT
LDG-15			326	382	502	340	127	72	503	1/2"	3/4"	40
			12,8	15,0	19,8	13,4	5,0	2,8	19,8			88
LDG-20			326	382	524	356	119	72	503	1/2"	3/4"	40
			12,8	15,0	20,6	14,0	4,7	2,8	19,8			88
LDG-25			326	382	568	355	125	72	503	1/2"	3/4"	40
			12,8	15,0	22,4	14,0	4,9	2,8	19,8			88
LDG-30			326	382	589	386	119	72	503	1/2"	3/4"	40
			12,8	15,0	23,2	15,2	4,7	2,8	19,8			88
LDG-35			326	382	658	409	153	72	503	1/2"	3/4"	40
			12,8	15,0	25,9	16,1	6,0	2,8	19,8			88
LDG-40			326	382	674	426	149	72	503	1/2"	3/4"	40
			12,8	15,0	26,5	16,8	5,8	2,8	19,8			88
LDG-50			326	382	758	463	160	72	503	1/2"	3/4"	40
			12,8	15,0	29,8	18,2	6,3	2,8	19,8			88

(*) Note: for this measure see LDG DIMENSIONAL - WEIGHT - VOLUME TABLES.

(**) This measure can be 1 or 2 x "P" NPT PORT upon request.

Mounting Interface Dimensions

LPS/LDG/LGO/LDG Series Coupling Dimensions													
Model	ISO 5211 Flange Interface (reference)	ØA	B	C	No. of Holes	Hole Diameter	P.C.D. [mm (inch)]	F	ØG	ØH	I	L	P
LPS/LDG/LGO/LDG-15	F16	65	10	70.6	4	M20	165 (6,50)	18	86	78	161	8	155
LPS/LDG/LGO/LDG-20	F25	86	12	91.6	8	M16	254 (10)	16	130	112	178	4.5	205
LPS/LDG/LGO/LDG-25	F30	100	18	108.8	8	M20	298 (11,73)	18	150	133	201	6	230
LPS/LDG/LGO/LDG-30	F35	130	28	138.6	8	M30	356 (14,02)	28	168	152	261	10	305
LPS/LDG/LGO/LDG-35	F40	150	36	166.8	8	M36	406 (15,98)	33	199	185	323	9	405
LPS/LDG/LGO/LDG-40	F48	185	45	205.8	12	M36	483 (19,02)	38	244	230	338	10	450
LPS/LDG/LGO/LDG-50	F60	230	50	252.8	20	M36	603 (23,74)	48	292	275	500	18	550

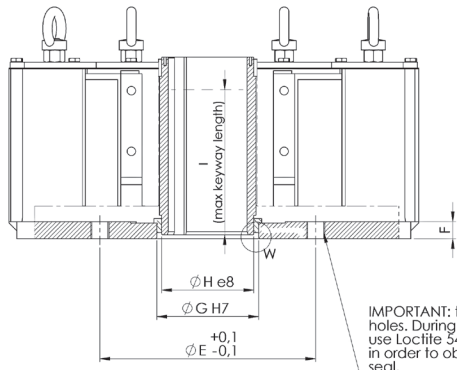
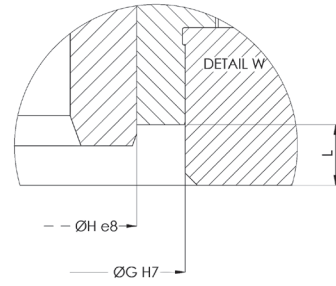
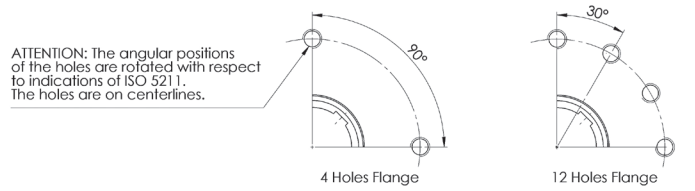
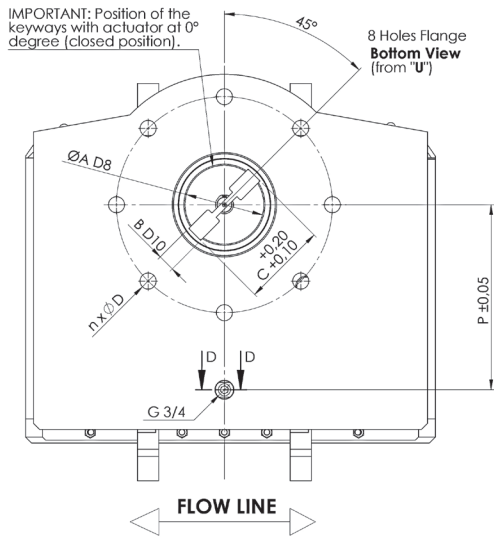

IMPORTANT: threaded through holes. During studs assembly use Loctite 542 (or equivalent) in order to obtain a perfect seal. Stud threaded length must not exceed "F" + 3 mm.

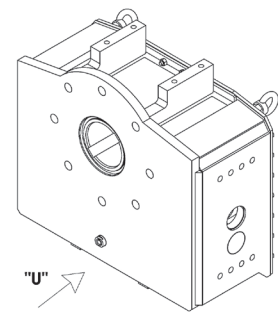
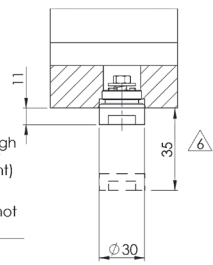

Service Kits

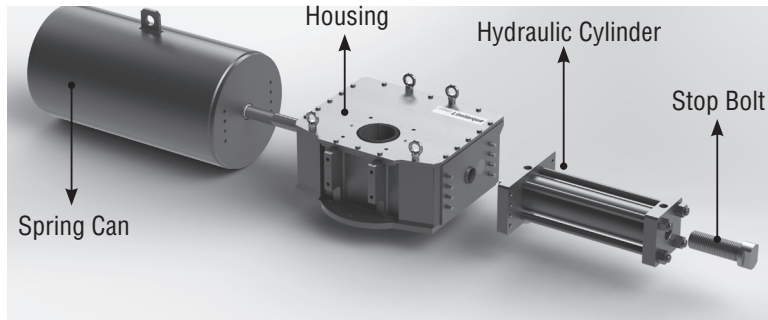

Figure 11: Single Acting Actuator

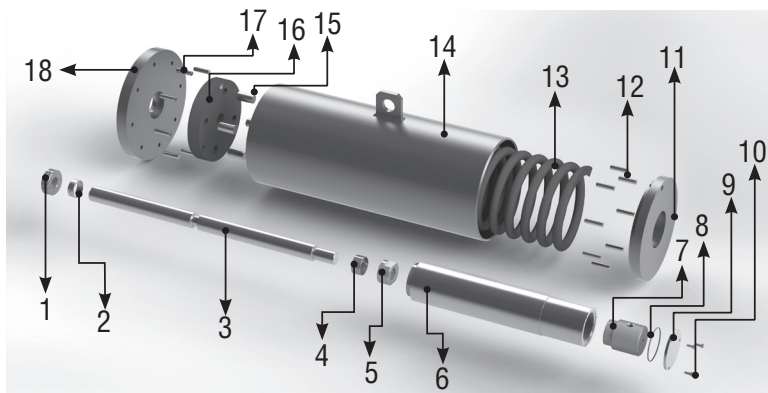

Figure 12: Spring Can Exploded View

Number	Description
1	Split Ring
2	Bushing
3	Spring Rod
4	Bushing
5	Spring Rod End Nut
6	Spring Guide
7	Spring Stop Bolt
8	O-Ring
9	Stop Bolt Cap

Number	Description
10	Hex Screw
11	Spring Can End Flange
12	Bar Pin
13	Spring
14	Spring Can
15	Bar Pin
16	Spring Plate
17	Bar Pin
18	Spring Can Head Flange

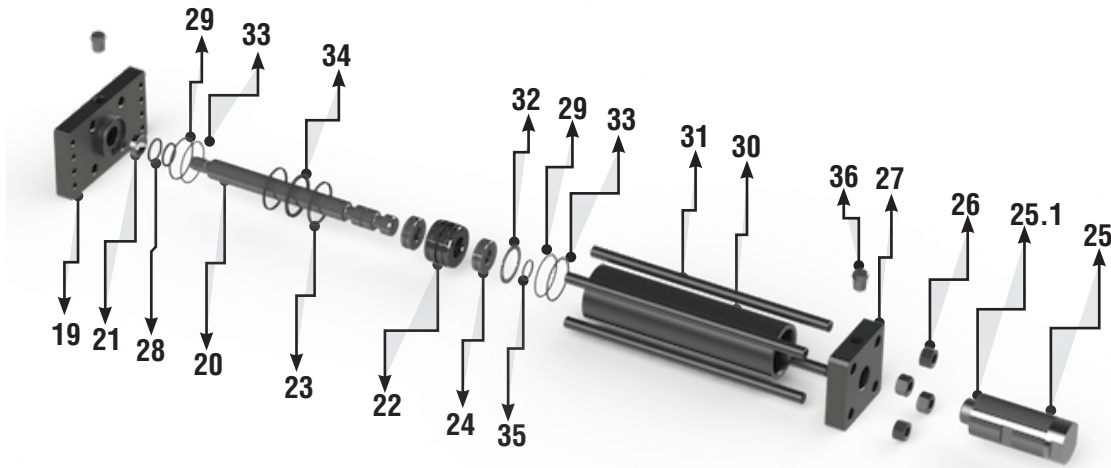

Figure 13: Exploded View of Hydraulic Cylinder – split ring version

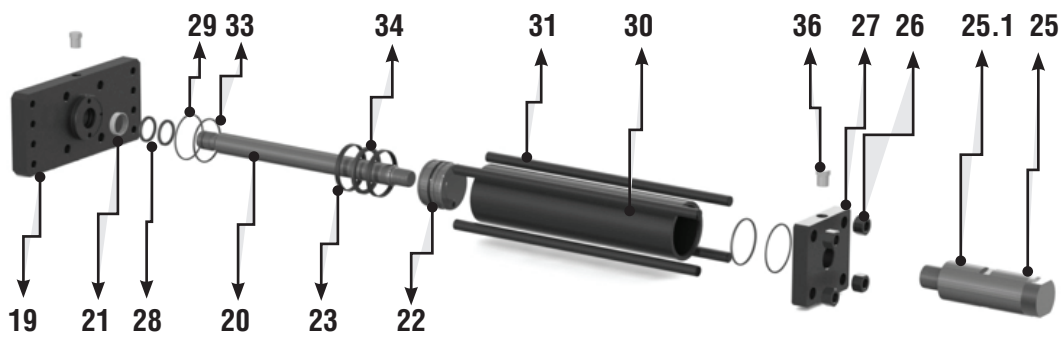

Figure 14: Exploded View of Hydraulic Cylinder – threaded piston version

Number	Description	Spare Parts*
19	Cylinder Head Flange	
20	Piston Rod	
21	Bushing	X
22	Piston	
23	Guide Ring (x2)	X
24	Split Ring	
25	Stop Bolt Assembly	
25,1	Stop Bolt Protection	
26	Hex Nut (High)	
27	Cylinder End Flange	

Number	Description	Spare Parts*
28	O-Ring (x2)	X
29	Parback Ring (x2)	X
30	Tube	
31	Tie Rod	
32	Spiral Retaining Shaft Ring	
33	O-Ring	X
34	Seal	
35	O-Ring	
36	Plugs	

* Standard maintenance spare parts for on/off applications

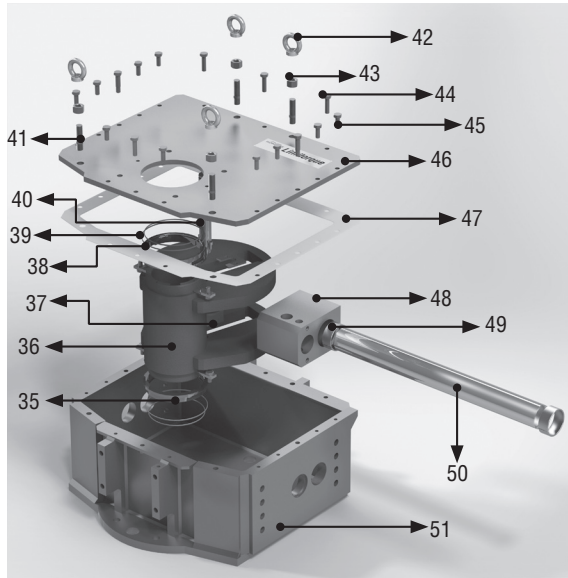

Figure 15: Exploded View of Housing

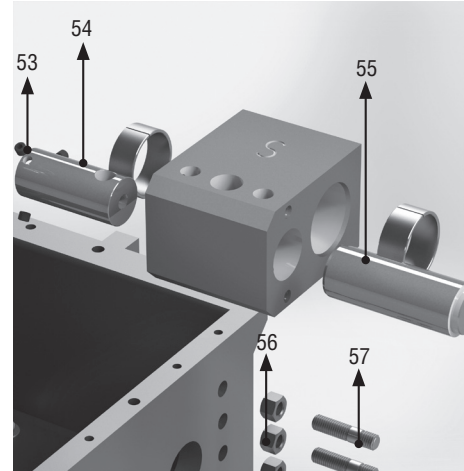

Figure 16: Exploded View of Adaptor Kit

Number	Description	Spare Parts*
35	Bushing	
36	Scotch Yoke	
37	Slider Block (x2)	
38	O-Ring	X
39	O-Ring	X
40	Guide Pin	
41	Stud	
42	Eyebolt	
43	Hex nut (High)	
44	Hex Head Shoulder Bolt	
45	Hex Head Screw	
46	Cover	
47	Cover Gasket	X

Number	Description	Spare Parts*
48	Guide Block	
49	Bushing	
50	Guide Bar	
51	Housing	
52	Center Ring	
53	Grub Screw	
54	Cylinder Adaptor	
55	Spring Adaptor	
56	Hex Nut (High)	
57	Stud	
58	Guide Adaptor Pin ¹	
59	Hex Head Screw ¹	

*Standard Maintenance Spare Parts for On/Off Application

¹Only in the double acting actuators

CW/CCW Conversion Kit Sample	
Number	Description
49	Bushing
54	Cylinder Adaptor
55	Spring Adaptor
56	Hex Nut (High)
57	Studs



FCD LFENTB0005-00-AQ Printed in USA. 06/2016.

To find your local Flowserve representative
or for more information about Flowserve Corporation,
visit www.flowserve.com or call USA 1 800 225 6989 or
International +1 972 910 0774

Flowserve Corporation has established industry leadership in the design and manufacture of its products. When properly selected, this Flowserve product is designed to perform its intended function safely during its useful life. However, the purchaser or user of Flowserve products should be aware that Flowserve products might be used in numerous applications under a wide variety of industrial service conditions. Although Flowserve can (and often does) provide general guidelines, it cannot provide specific data and warnings for all possible applications. The purchaser/user must therefore assume the ultimate responsibility for the proper sizing and selection, installation, operation, and maintenance of Flowserve products. The purchaser/user should read and understand the Installation Operation Maintenance (IOM) instructions included with the product, and train its employees and contractors in the safe use of Flowserve products in connection with the specific application.

While the information and specifications contained in this literature are believed to be accurate, they are supplied for informative purposes only and should not be considered certified or as a guarantee of satisfactory results by reliance thereon. Nothing contained herein is to be construed as a warranty or guarantee, express or implied, regarding any matter with respect to this product. Because Flowserve is continually improving and upgrading its product design, the specifications, dimensions and information contained herein are subject to change without notice. Should any question arise concerning these provisions, the purchaser/user should contact Flowserve Corporation at any one of its worldwide operations or offices.

© 2016 Flowserve Corporation, Irving, Texas, USA. Flowserve is a registered trademark of Flowserve Corporation.

**Flowserve Limitorque
Fluid Power Systems
Product Sales**

Via Rio Vallone 17
20883 Mezzago (MB), Italy
Phone: +39 039 62060 1
Fax: +39 039 62060 213
Email: lfpsinfo@flowserve.com

**Flowserve Limitorque
Fluid Power Systems
Manufacturing and Operations**

Via Rio Vallone 17
20883 Mezzago (MB), Italy
Phone: +39 039 62060 1
Fax: +39 039 62060 213
Email: lfpsinfo@flowserve.com

**Flowserve Limitorque
Fluid Power Systems
Research and Development**

Via Belizzi 40/42
29122 Piacenza (PC), Italy
Email: lfpsinfo@flowserve.com