



Flowserve Solenoid Valves

Namur, Remote and Banjo Mounted Designs for Precision Control



Experience In Motion

Flowserve® – Solutions to Keep You Flowing

Flowserve is one of the world's leading providers of fluid motion and control products and services. Globally, we produce engineered and industrial pumps, valves, seals, systems and automation equipment, and provide a range of related flow management services. Our solutions move even the most volatile and corrosive fluids safely and securely through some of the most extreme temperatures, terrain and challenging operating environments on the planet. Flowserve products and services are specified for use in a vast range of industries, including oil and gas, chemical, power generation and various general industries.



Flowserve Solenoid Valves

Flowserve offers a comprehensive suite of highly engineered valves, actuators, switchboxes, positioners and solenoid solutions that meet your exacting needs. Our solenoid valves allow reliable operation of pneumatically controlled valves and provide critical plant control in a variety of automated process industry applications. Solenoid valves are an essential part of any pneumatic actuated or control valve package offering remote operation, improved reliability and longer service life.

Available in a range of design configurations to meet specific application needs, Flowserve solenoid valves can be Namur (Direct) mounted onto compact actuators, Remote mounted for control valves and panels or screwed directly to the actuator air supply using a Banjo mounted design. Combined with a suitable coil to meet voltage and safety requirements, Flowserve solenoid valves ensure safe, reliable and precise actuator operation.

Key Benefits

- Reduced costs at the asset level through prolonged service life delivered by cost competitive Flowserve package solutions.
- Improved process integrity and safer working environment when used in combination with a comprehensive range of ATEX, IECEx, NEMA, FM and CSA certified solenoid coils. NEPSI and GOST approved products are available on request.
- Simplified and convenient procurement through availability of a comprehensive suite of Flowserve custom-engineered valves, actuators, switch boxes, positioners and solenoid valves.



ARF Series, 1/4", 3/2 or 5/2 way NAMUR Mounted Solenoid Valve

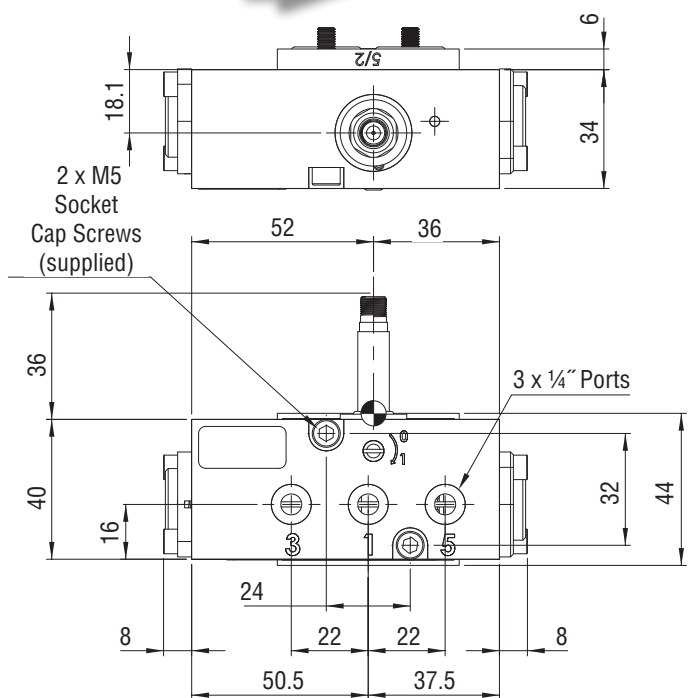
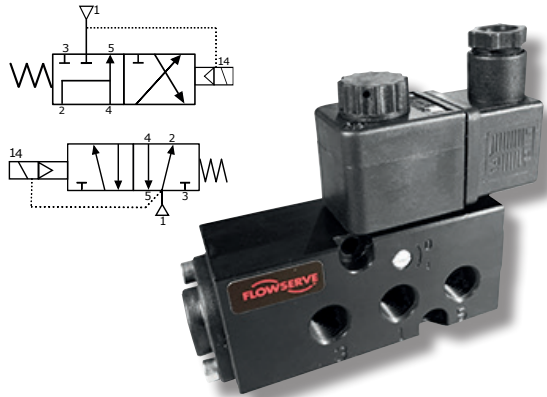

Description

Solenoid valve designed for direct mounting onto 1/4 turn pneumatically operated valve actuators meeting 'NAMUR' standard fixing dimensions. Hazardous area approved pilot operators, Ex nA, Ex mb, Ex db mb and Ex ia, NEMA 4X, NEMA 4X, 7C, 7D & 9 are available with various international approvals – ATEX, IECEx, FM, CSA.

Features

- Screwdriver override as standard
- Cv = 1.0
- Change-over plate that allows the valve to be converted from 3/2 to 5/2 function quickly and easily for spring return and double acting actuators
- In the 3/2 position, a feature of the valve allows a proportion of clean air exhausting from the actuator to be fed back into the spring chamber, Integrated Exhaust to Spring (ETS)

Valve Specifications

Port Connection Size	1/4"
Working Pressure	3 to 10 bar
Cv Factor	1.0
Flow Rate (at 6 bar with 1 bar pressure drop)	1000 l/min
Maximum Ambient Temperature	+80°C
Minimum Working Temperature	-20 °C

Materials of Construction

Body	Black Anodised Aluminium
Spool	Hard Anodised Aluminium PTFE Impregnated
Spacers	Glass Filled Acetal
Seals	Nitrile
Spring	Steel Alloy
Mounting Screws	Stainless Steel
Change Over Plate and End Caps	Nylon 66 30% Glass Filled
Gasket	Nitrile

Valve								Coil						
A	R	F		5	S	3	1	-				0		1

Port	G	2
	NPT	P

Plug	9	PG9
	F	Flying Lead

B	24 V DC	Voltage
R	24 V AC 50/60 Hz	
T	110 V AC 50/60 Hz	
L	**230 V AC 50/60 Hz	

Example Valve and Coil Selection

ARFP5S3A-X0DB0F1

- Namur Valve
- NPT 1/4
- NEMA 4X, 7C, 7D & 9 coil
- FM + CSA approved
- 24 V DC
- Flying lead (24", standard)

Coil Type	A	0	0	Safe Area	None	Approval
	S	0	B	Ex ia	ATEX + IECEx	
	T	0	A	Ex db mb	ATEX	
	U	0	A	Ex nA	ATEX	
	V	0	A	*Ex mb	ATEX	
	W	0	0	*NEMA 4X (Safe area)	None	
X	0	D	*NEMA 4X, 7C, 7D & 9	FM + CSA		

Note * Flying leads as standard (see 'COIL DETAILS')
 ** NEMA 4X, 7C, 7D and 9, frequency = 60 Hz

AEF Series, 1/4", 3/2 way Remote Mounted Solenoid Valve

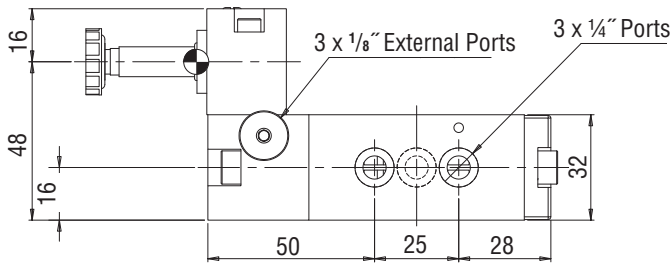
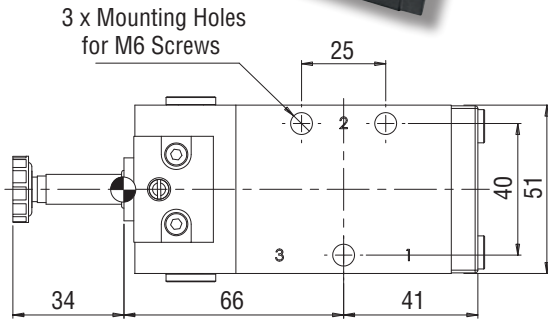
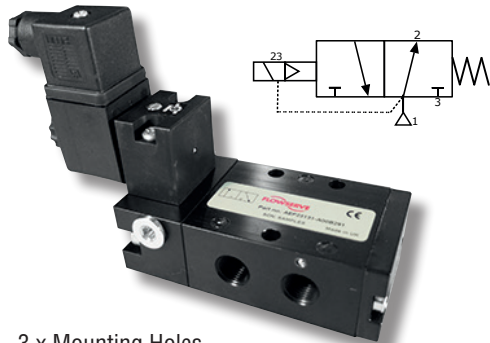

Description

Aluminium 5 port 3 or 2 position, pilot operated solenoid valve. Hazardous area approved pilot operators, Ex nA, Ex mb, Ex db mb and Ex ia, NEMA 4X, NEMA 4X, 7C, 7D & 9 are available with various international approvals – ATEX, IECEx, FM, CSA.

Features

- External or internal pilot air connection
- Single coil spring return function or double coil stay put function
- Convenient fixing holes to enable bracket mounting
- Pilot exhaust dust caps fitted as standard
- Interchangeable CNOMO interface coil units, including hazardous area options and screw driver manual override as standard.
- SIL2 on energising, SIL3 on de-energising when used in 3/2 mode

Valve Specifications

Port Connection Size	1/4"
Working Pressure Internal Pilot Version	3 to 10 bar
Working Pressure External Pilot Version	3 to 10 bar
Cv Factor	1.2
Flow Rate (at 6 bar with 1 bar pressure drop)	1246 l/min
Maximum Ambient Temperature	+80 °C
Minimum Working Temperature	-20 °C

Materials of Construction

Body and End Caps	Black Anodised Aluminium
Spool	Hard Anodised Aluminium PTFE Impregnated
Jet	Brass
Spacers	Glass Filled Acetal
Seals	Nitrile (Alternative Seals Available)
Spring	Steel Alloy

Valve

A	E	F		3	1	3	1
Port		G	2				
		NPT	P				

Coil

				2		1
				Plug	9	PG9
					F	Flying Lead
				B	24 V DC	
				R	24 V AC 50/60 Hz	
				T	110 V AC 50/60 Hz	
				L	**230 V AC 50/60 Hz	
Coil Type	A	0	0	Safe Area	None	
	S	0	B	Ex ia	ATEX + IECEx	
	T	0	A	Ex db mb	ATEX	
	U	0	A	Ex nA	ATEX	
	V	0	A	*Ex mb	ATEX	
	W	0	0	*NEMA 4X (Safe area)	None	
X	0	D	*NEMA 4X, 7C, 7D & 9	FM + CSA		
Note	* Flying leads as standard (see 'COIL DETAILS')					
	** NEMA 4X, 7C, 7D and 9, frequency = 60 Hz					

Example Valve and Coil Selection

A E F 2 3 1 3 1 - X 0 D B 2 F 1

Remote 3/2 Way Valve
 G 1/4
 NEMA 4X, 7C, 7D & 9 coil
 FM + CSA approved
 24 V DC
 Flying lead (24", standard)

AEF Series, 1/4", 5/2 or 5/3 way Remote Mounted Solenoid Valve

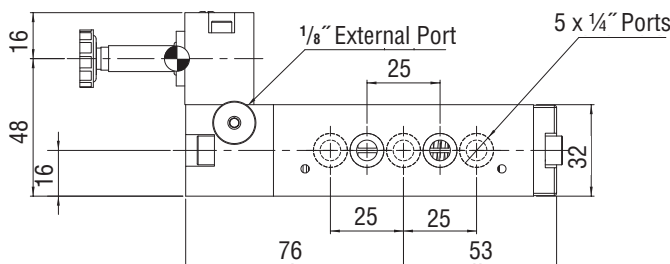
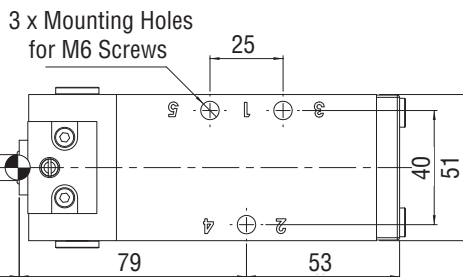
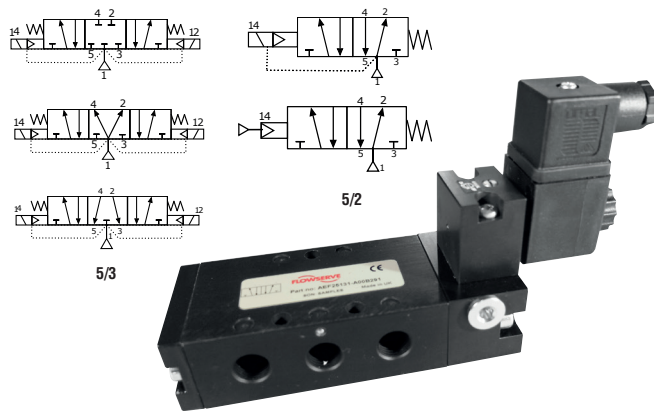

Description

Aluminium 5 port 3 or 2 position, pilot operated solenoid valve. Hazardous area approved pilot operators, Ex nA, Ex mb, Ex db mb and Ex ia, NEMA 4X, NEMA 4X, 7C, 7D & 9 are available with various international approvals – ATEX, IECEx, FM, CSA.

Features

- External or internal pilot air connection
- Single coil spring return function or double coil stay put function
- Convenient fixing holes to enable bracket mounting
- Pilot exhaust dust caps fitted as standard
- Interchangeable CNOMO interface coil units, including hazardous area options and screw driver manual override as standard.
- SIL2 on energising, SIL3 on de-energising when used in 3/2 mode

Valve Specifications

Port Connection Size	1/4"
Working Pressure Internal Pilot Version	3 to 10 bar
Working Pressure External Pilot Version	3 to 10 bar
Minimum External Pilot Pressure	3 bar
Cv Factor	1.2
Flow Rate (at 6 bar with 1 bar pressure drop)	1246 l/min
Maximum Ambient Temperature	+80 °C
Minimum Working Temperature	-20 °C

Materials of Construction

Body and End Caps	Black Anodised Aluminium
Spool	Hard Anodised Aluminium PTFE Impregnated
Jet	Brass
Spacers	Glass Filled Acetal
Seals	Nitrile (Alternative Seals Available)
Spring	Steel Alloy

Valve							Coil							
A	E	F				1	-					2		1
A	Includes coil(s)		Assy										9	PG9
V	Air Pilot Only												F	Flying Lead
Port	G		2											
	NPT		P											
Internal Piloted Valve Type	5/2					5								
	5/3 - Mid closed					6								
	5/3 - Mid open					7								
	5/3 - Mid pressurised					8								
External Piloted Valve Type	5/2					E								
	5/3 - Mid closed					F								
	5/3 - Mid open					G								
	5/3 - Mid pressurised					H								
Operator 1	Solenoid					1								
	Air Pilot Return					5								
Operator 2	Solenoid					1								
	Spring Return					3								
	Air Pilot Return					5								
Coil Type	A	0	0	Safe Area	None									
	S	0	B	Ex ia	ATEX + IECEx									
	T	0	A	Ex db mb	ATEX									
	U	0	A	Ex nA	ATEX									
	V	0	A	*Ex mb	ATEX									
	W	0	0	*NEMA 4X (Safe area)	None									
	X	0	D	*NEMA 4X, 7C, 7D & 9	FM + CSA									
Note	* Flying leads as standard (see 'COIL DETAILS')													
	** NEMA 4X, 7C, 7D and 9, frequency = 60 Hz													

ADF Series, 1/8" & 1/4", 3/2 way Banjo Mounted Solenoid Valve

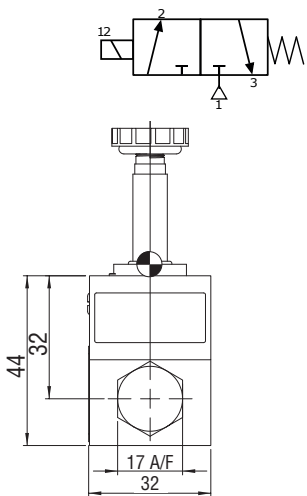

Description

Aluminium 3 port 2 position direct acting, compact solenoid valve designed for direct banjo bolt mounting onto 1/4 turn pneumatically operated valve actuators.

Features

- Convenient single 1/8" or 1/4" Banjo bolt connection
- Compact design to suit small actuators
- 1/4" BSP mains air connection and M5 exhaust
- Screwdriver manual override standard

Valve Specifications

Inlet Port Connection Size	1/4"
Outlet Port Connection Size	1/8" or 1/4" Banjo Bolt
Exhaust Port Connection Size	M5
Working Pressure	0 to 10 bar
Cv Factor	0.06
Flow Rate (at 6 bar with 1 bar pressure drop)	62 l/min
Maximum Ambient Temperature	+80 °C
Minimum Working Temperature	-20 °C

Materials of Construction

Body	Black Anodised Aluminium
Banjo Bolt	Brass Nickel Plated
Jet	Black Anodised Aluminium
Seals	Nitrile & Viton

Port 3 (Exhaust) via M5 thread in top of Stem

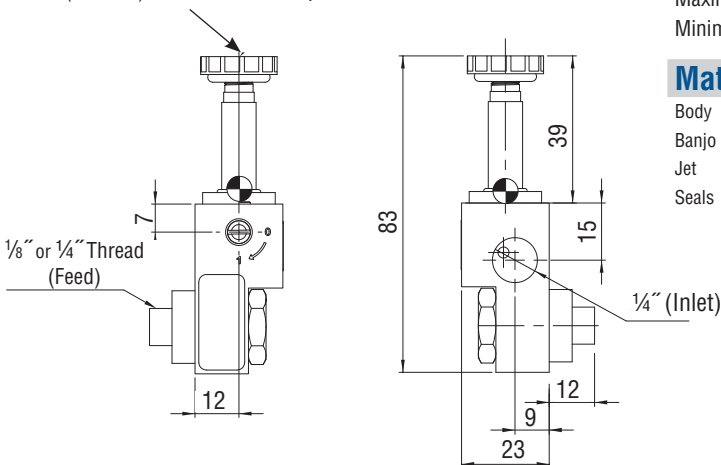

Valve

A	D	F		3	S	3	1
	1/4"	G	2				
		NPT	P				
	1/8"	G	1				
		NPT	N				

Coil

				0		1
				Plug	9	PG9
					F	Flying Lead
				B	24 V DC	
				R	24 V AC 50/60 Hz	
				T	110 V AC 50/60 Hz	
				L	**230 V AC 50/60 Hz	
					Voltage	

Example Valve and Coil Selection

ADF23S31-X0YB0F1

Banjo 3/2 Way Valve
 G 1/4
 NEMA 4X, 7C, 7D & 9 coil
 CSA approved
 24 V DC
 Flying lead (24", standard)

Coil Type	A	0	0	Safe Area	None
	S	0	B	Ex ia	ATEX + IECEx
	T	0	A	Ex db mb	ATEX
	U	0	A	Ex nA	ATEX
	V	0	A	*Ex mb	ATEX
	W	0	0	*NEMA 4X (Safe area)	None
X	0	D	*NEMA 4X, 7C, 7D & 9	FM + CSA	
					Approval

Note * Flying leads as standard (see 'COIL DETAILS')
 ** NEMA 4X, 7C, 7D and 9, frequency = 60 Hz

Coils

COIL DETAILS

Coil Type	MC30	NEMA 4X	Ex nA IIC T5 Gc	Ex mb T4, T5	Ex db mb IIC T4, T5	Ex m T4	Ex ia IIC T6 Ga
Area Class	Safe Area	Safe Area	ATEX Zone 2	ATEX Zones 1 & 2	ATEX Zones 1 & 2	FM/CSA CL1 Zone 1	IECEX/ATEX Zone 0,1 & 2
Area Category	N/A	N/A	Cat 3 GD	Cat 2 GD	Cat 2 GD	CL1; Div 1 & 2 Gr A,B,C,D	Cat 1 GD
Ingress Protection	IP65	NEMA 4X	IP65	IP65	IP66	Nema 4, 4X,7C,7D & 9	IP65
Power Consumption DC	2.0	4.8	2.1	3.0 (T5) 3.8 (T4)	3.0 (T5) 3.8 (T4)	4.5	21.6-28.0 volts DC min 37mA switch on current
Power Consumption AC V/A	5.0	8.5	4.0 (50 Hz) 3.1 (60 Hz)	3.2 (50Hz) (T5) 2.7 (60Hz) (T5)	3.2 (50Hz) (T5) 2.7 (60Hz) (T5)	6.9	
Cable Entry	PG.9	½" NPT with 24" Flying Lead	PG.9	Flying Lead (3m)	PG.9	½" NPT with 24" Flying Lead	PG.9
Ambient Temperature	-20 to +50 °C	-20 to +60 °C	-20 to +50 °C	-20 to +65 °C	-50 to +50 °C	-20 to +60 °C	-40 to +50 °C
Magnetic Wire Class	H	H	H	H	H	H	H

COIL DIMENSIONS (mm)

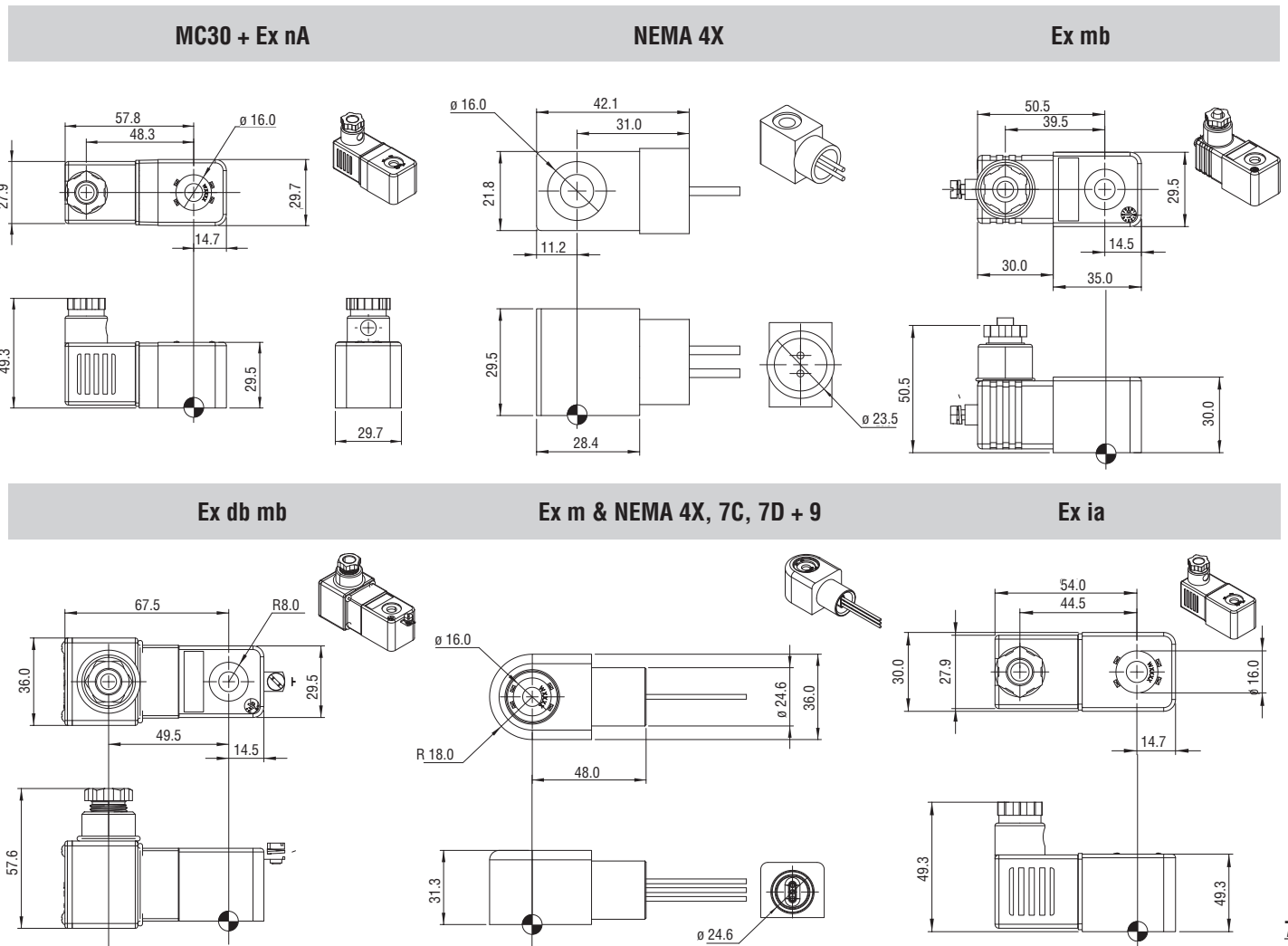



Flowserve Flow Control GmbH
Rudolf-Plank Strasse 2 D-76275 Ettlingen
Germany
Tel: +49 (0) 7243 103 0
Fax: +49 (0) 7243 103 222
E-mail: argus@flowserve.com

Flowserve Flow Control Benelux
Rechtzaad 17
4703 RC Roosendaal
The Netherlands
Tel: +31 (0) 30 6771946
Fax: +27 (0) 30 6772471
E-mail: fcbinfo@flowserve.com

Flowserve Spa
Via Prealpi, 30
20032 Cormano (Milano)
Italy
Tel: +39 (0) 2 663 251
Fax: +39 (0) 2 615 18 63
E-mail: infoitaly@flowserve.com

Flowserve Essen GmbH
Schederhofstr. 71
45145 Essen
Germany
Phone: +49 201 8919 5
Fax: +49 201 8919 662

Flowserve Flow Control (UK) Ltd.
Burrell Road
Haywards Heath
West Sussex, United Kingdom RH16 1TL
Phone: +44 1444 314400
Fax: +44 1444 314401

Flowserve Suzhou Operations
49 Weixin Road,
Suzhou Industrial Park
Suzhou 215122
Jiangsu Province, China
Fax: 86-512-62888737
Tel: 86-512-62888790

Flowserve Corporation
Flow Control Division
1978 Foreman Drive
Cookeville, Tennessee 38501, USA
Phone: +931 432 4021
Fax: +931 432 5518

Flowserve Corporation
14219 Westfair West Drive
Houston, TX 77041, USA
Tel: +1 281 671 9209
Fax: +1 281 671 9268
E-mail: pmvsales@flowserve.com

Flowserve Corporation
Flow Control Division
1350 N. Mt. Springs Parkway
Springville, UT 84663, USA
Phone: 801-489-8611
Fax: 801-489-3719

Flowserve banded solenoids can only be purchased through Flowserve associate companies. Details can be found on:

www.flowserve.com

Your Contact:

FCD FCENBR0010-01 AQ 11/18 Printed in USA.

Flowserve Corporation has established industry leadership in the design and manufacture of its products. When properly selected, this Flowserve product is designed to perform its intended function safely during its useful life. However, the purchaser or user of Flowserve products should be aware that Flowserve products might be used in numerous applications under a wide variety of industrial service conditions. Although Flowserve can (and often does) provide general guidelines, it cannot provide specific data and warnings for all possible applications. The purchaser/user must therefore assume the ultimate responsibility for the proper sizing and selection, installation, operation, and maintenance of Flowserve products. The purchaser/user should read and understand the Installation Operation Maintenance (IOM) instructions included with the product, and train its employees and contractors in the safe use of Flowserve products in connection with the specific application.

While the information and specifications contained in this literature are believed to be accurate, they are supplied for informative purposes only and should not be considered certified or as a guarantee of satisfactory results by reliance thereon. Nothing contained herein is to be construed as a warranty or guarantee, express or implied, regarding any matter with respect to this product. Because Flowserve is continually improving and upgrading its product design, the specifications, dimensions and information contained herein are subject to change without notice. Should any question arise concerning these provisions, the purchaser/user should contact Flowserve Corporation at any one of its worldwide operations or offices.

© 2017 Flowserve Corporation, Irving, Texas, USA. Flowserve is a registered trademark of Flowserve Corporation.