



TECHNICAL BULLETIN

Kammer Multi-Z Severe Service Valves

FCD KMENTB1631-02 07/12



Experience In Motion

Specifications

Size	ANSI 1 - 4 inch (globe cast) ANSI 1 - 8 inch and DIN DN 25 - 200 (globe and angle forged) Other sizes upon request
Pressure class	Class 600 - 1500 PN 63-250 Other pressure classes upon request
Body materials	Carbon steel (WCB, WCC, A105) Stainless steel (CF8M, 316SS) Other materials upon request
Body type	Angle and globe
End connections	Weld ends Flanges acc. to ANSI and DIN Threaded NPT (up to 2") Different inlet and outlet size Other end connections upon request
Face to face	ANSI / ISA 75.08.01 (CI 300 - 600 globe) ANSI / ISA 75.08.06 (CI 900 - 1500 globe) DIN EN 558 (globe) Flowserve standard angle
Trim type	Balanced or unbalanced Multistage trim 3-6 stages (number of stages as dictated by service conditions) Optional venturi nozzle outlet
Trim designs (see pages 10 to 13)	Standard trim First stage two notches Flow optimized trim First stage On-Off
Trim materials	See table on page 17
Shutoff	ANSI Class IV, V, optional ANSI Class VI
Flow characteristic	Modified Linear, Modified Equal Percentage and custom engineered
Stem Sealing (see page 6)	Standard PTFE, Graphite Fugitive emissions packing according to ISO 15848-1 and TA-Luft Metal bellows seal
Flow capacity and solid size	0.2 to 12.7 mm - see pages 10 to 13 for details
Actuator	Spring diaphragm actuator type KP (stainless steel) Spring diaphragm actuator type FlowAct (carbon steel) Piston actuator type VL / VL-ES Electric actuator Hydraulic actuator

Principle of Design

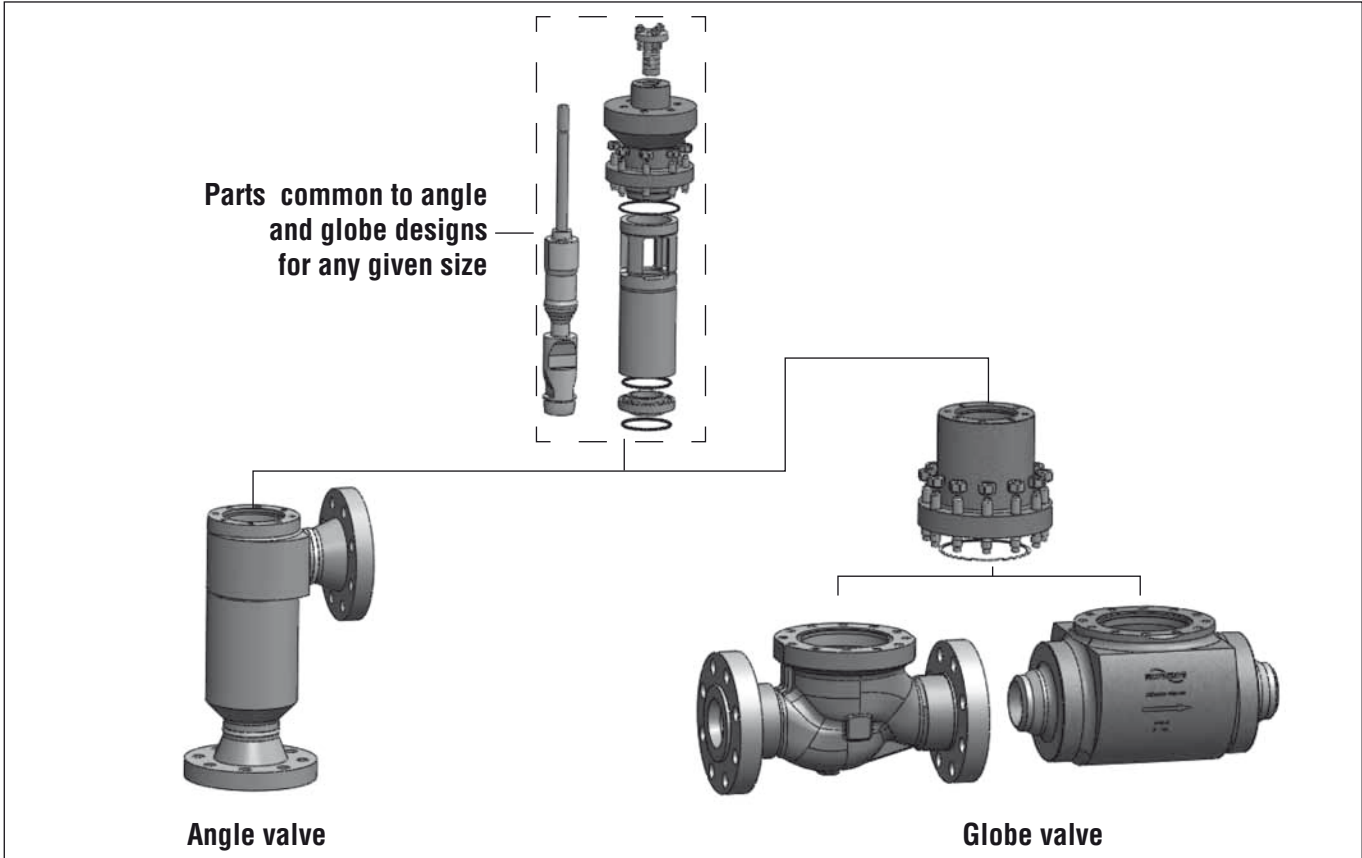

The internal parts and the bonnet are identical for both angle and globe valve designs for any given valve size.

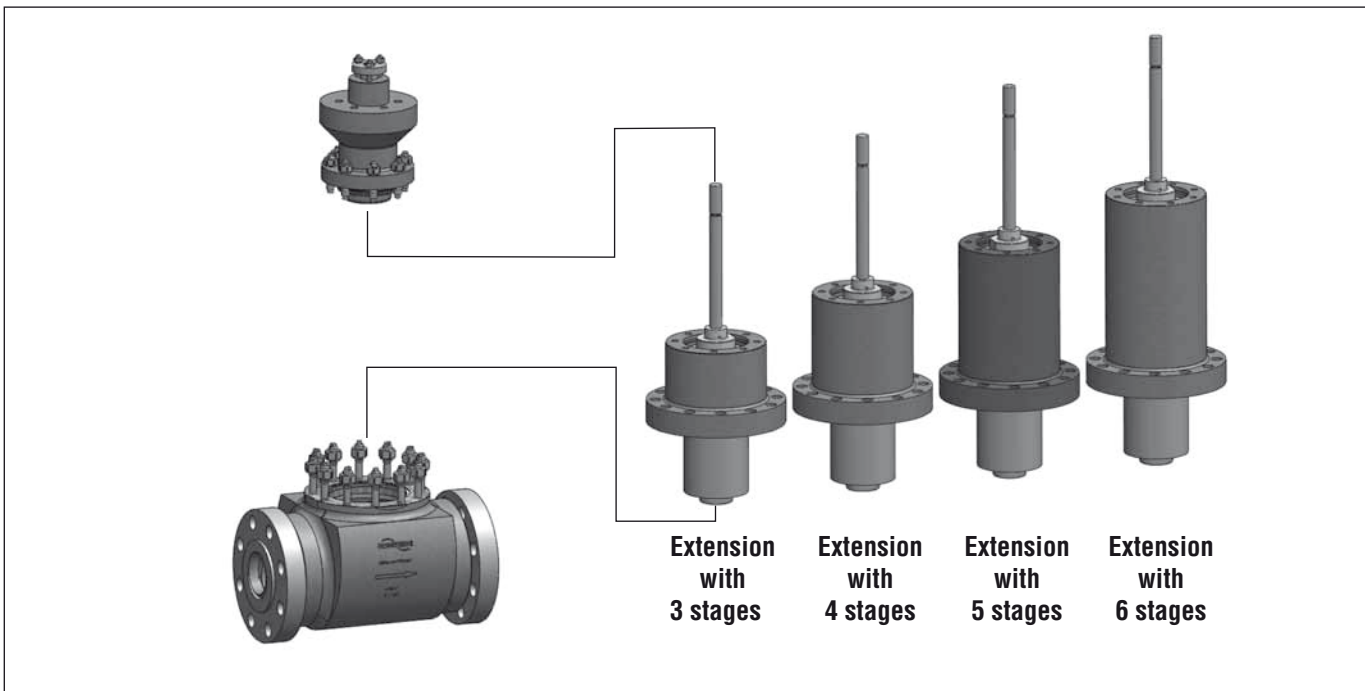

Globe valve: for a given valve size an extension with any number of stages can be chosen using the same body and bonnet. (field upgrade possible by changing the extension, plug and liner)

Principle of cavitation elimination

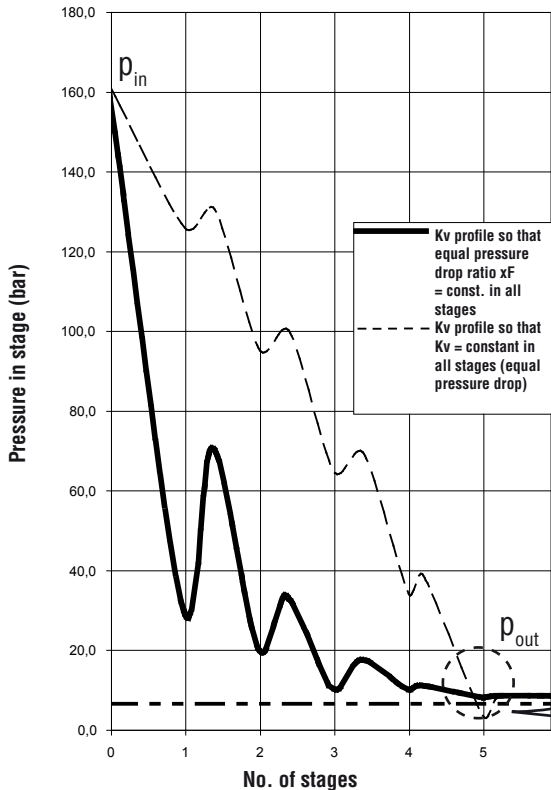

The phenomenon of cavitation occurs when the pressure of the medium drops, for a short time, below the vapor pressure (P_v). Behind the vena contracta the pressure recovers and cavitation occurs.

To achieve zero cavitation the Multi-Z trim divides the pressure drop into several parts (3-6, depending on the applications). Every stage is machined to keep the x_F (respective Σ) constant. The diagram illustrates the difference between constant ΔP (solid line) and constant x_F (dotted line). The advantage is the last stage where a small Δp does not reach P_v . Physically the Multi-Z uses the high potential in the first stages to have only a low ΔP in the last stage. This method is in accordance with ISA / ASME RP-75.23.

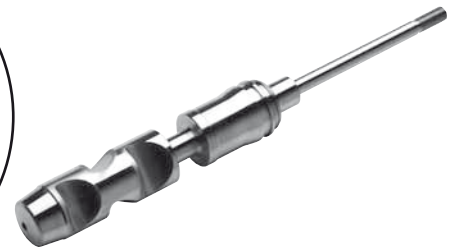
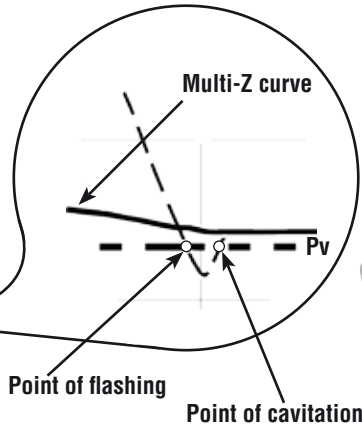

The trim is available with custom flow, modified linear and modified equal percentage characteristics. The first 10% of the stroke provides seat protection to achieve a better control resolution. The Multi-Z utilizes long stroke lengths through complete product range providing greater C_v .

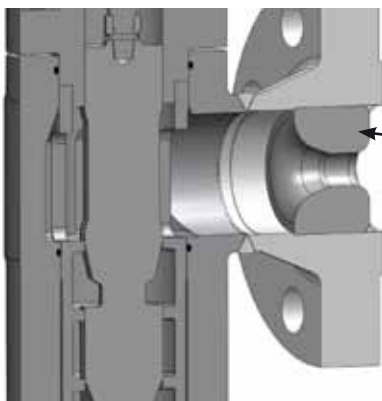
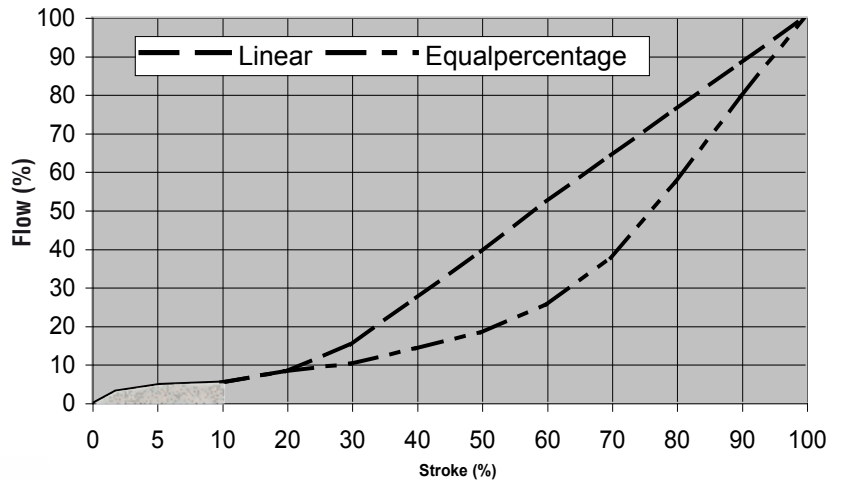

Venturi outlet nozzle

In flashing applications or where P_v is greater than P_2 the valve can be fitted with a venturi nozzle integrated into the outlet port. This will ensure that the pressure within the valve is always above the vapor pressure.

Industry Applications

Refinery	Charge Pump Recirculation
	Amine Letdown
	Hot High Pressure Letdown
	Cold High Pressure Letdown
Oilfield	Produced Water Injection
	HP Injection Control
Power	Boiler Feedwater Recirculation
	Boiler Feedwater Startup
All Plants	High Pressure Drop Applications
	Water Letdown

Packing options

Low emission sealing systems according to ISO 15848-1 and TA-Luft

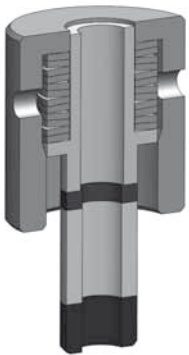

Compact design
up to PN 63 / CL 600



Mixed packing



V-Ring packing live loaded



Standard packing
PTFE or Graphite

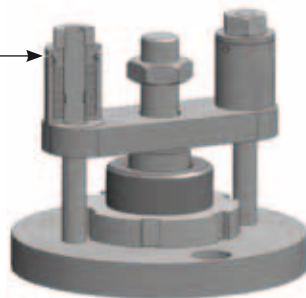
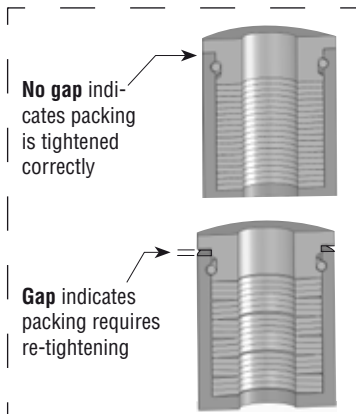

Packing cartridge
SAS preformed graphite packing with metal inlays and ISO certification 15848 B

Metal bellows seal

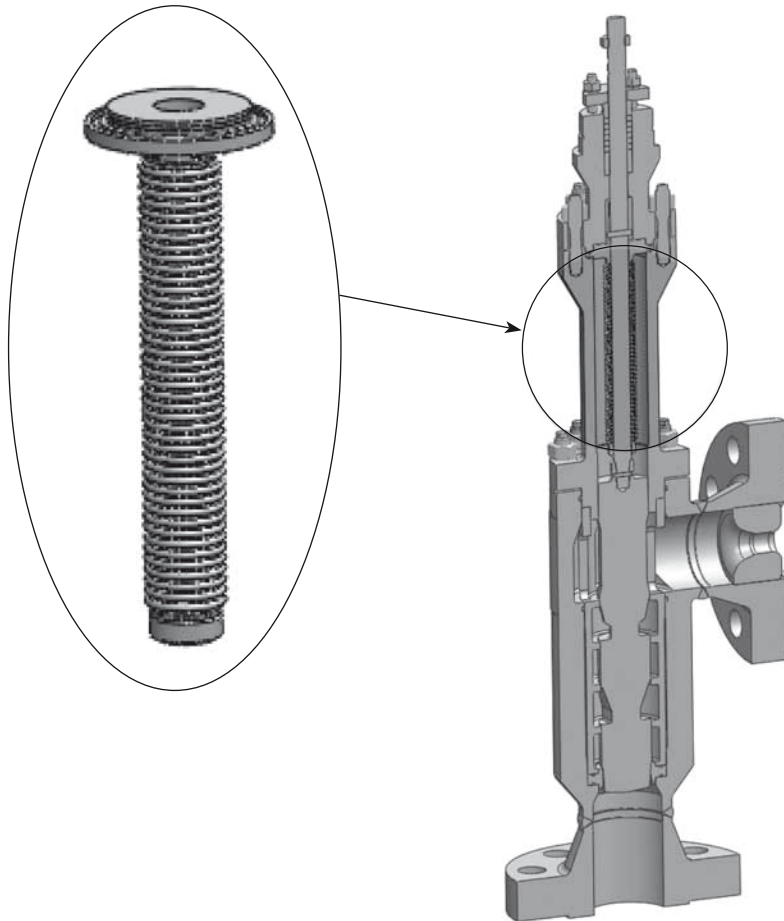

To protect personnel and the environment from toxic or aggressive media, these must be processed in a closed system. Kämmer metal bellows seals fulfill the requirements of the German regulation “TA-Luft” Kämmer’s design includes a rugged hydroformed bellows seal with the backup packing seal located well above the bellows. For maximum protection, bellows are provided with up to five walls having wall thickness from 0.1 to 0.15 mm (for greater wall flexibility). A leak detection port is standard.

Kämmer offers a variety of bellows seals, providing the best cycle life in the business. Depending on the pressure and temperature, bellows seal designs can exceed 1 million cycles. To ensure the integrity of the bellows seal, each new valve or bellows seal spare part is tested using a stringent helium leak test.

Instead of a welded bellows design, only hydroformed bellows seals are used because of their strength and ability to withstand pressure, especially in high pressure applications. Because minimal welding is required for hydroformed bellows, they are available in a wide variety of materials, such as 300 series stainless steels, Hastelloy® C 276, Nickel, Monel®, Titanium, Inconel® and PTFE.

Sealing options

According to medium and application the Multi-Z offers various sealing options.

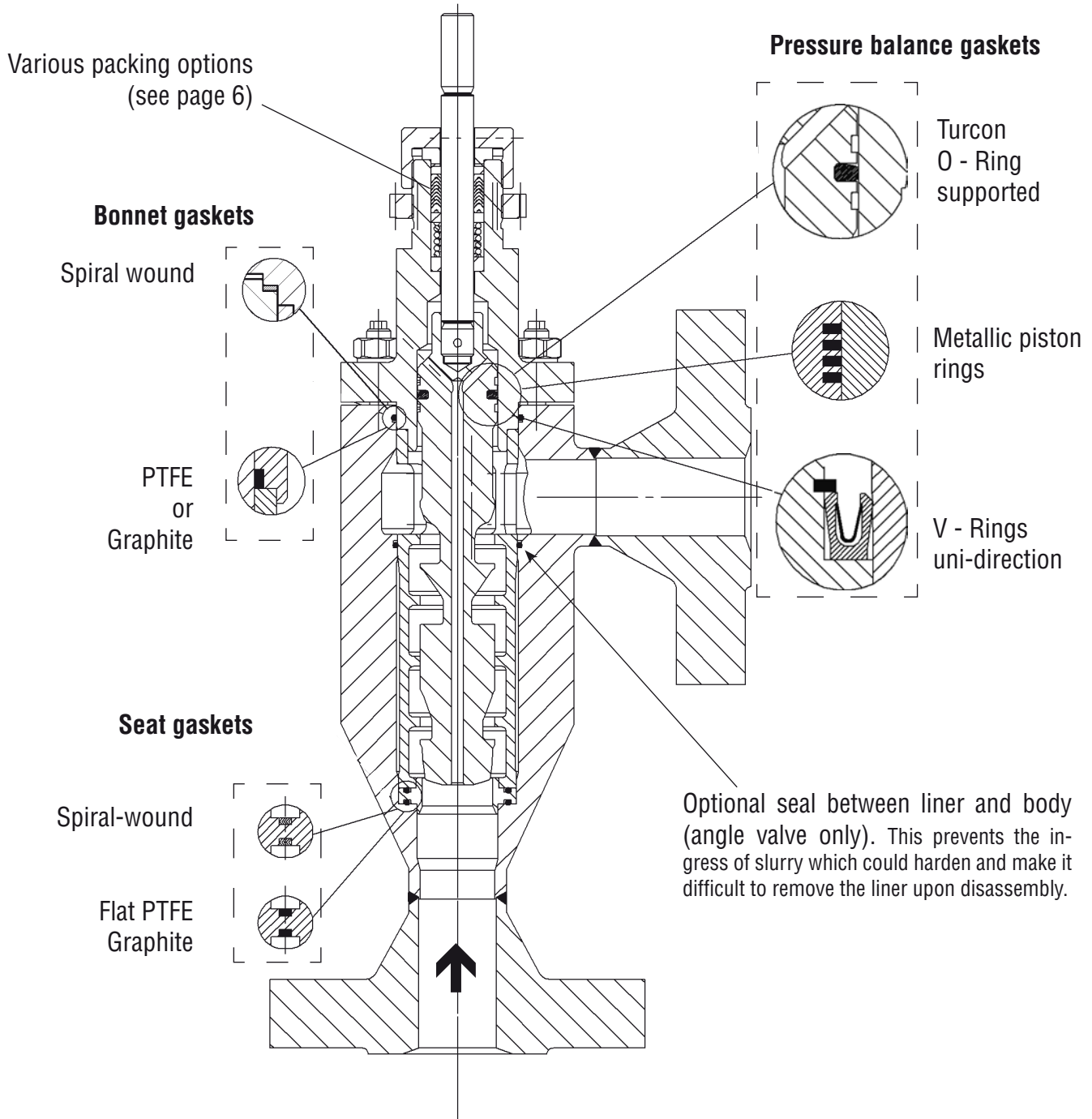

Soft seat

The soft seat parts move away from the Vena Contracta before flow commences to reduce erosion. In the shutoff position there is double contact from soft seat (primary) and metal to metal (secondary).

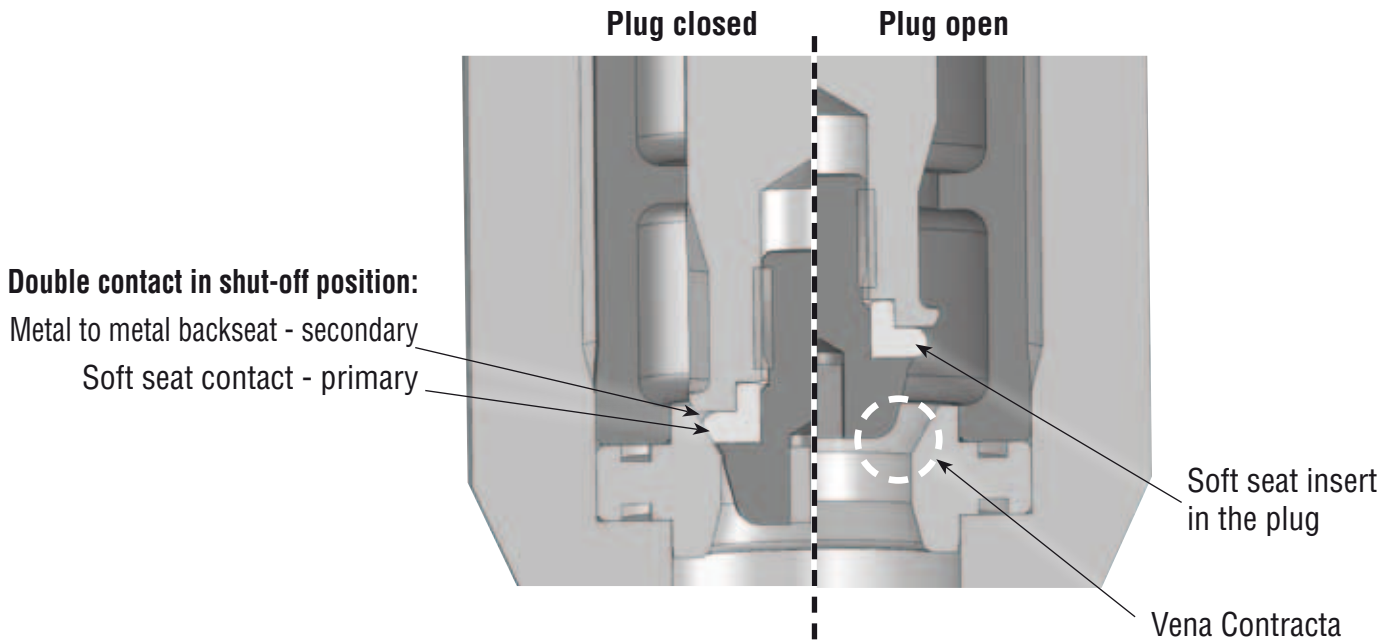

Flow capacity and solid size

The flow capacity is governed by the number of stages. More stages allow a higher pressure drop without cavitation. The AXIAL FLOW MULTI STAGE design provides multiple stages to maximize performance in a given service condition. The calculation is based on the xFz resp. Sigma, the indicator for incipient cavitation, used in ISA-RP 75.23.

A very important factor is the maximum solid size. Big solids require larger gaps where best cavitation avoidance requires smaller gaps. For this reason the Multi-Z can be supplied with 4 different trims:

Standard Trim

		DN	25	40/50	65	80	100	150	200	
Trim Design		Stroke [mm]	10	15	20	25	40	60	60	
3 stages ¹⁾	Standard Trim xFz total = 0.957 (0.8) σ total = 1.045 (1.25) ²⁾	Kvs	Kvs range ⁴⁾	1.0 - 2.3 (3.2)	2.7 - 7.8 (10.8)	4.2 - 15.9 (22.1)	5.1 - 21.6 (30.1)	8.0 - 40.7 (56.7)	12.9 - 79.6 (110)	18.2 - 129.8 (180)
			Kv controlable	0.1	0.25	0.42	0.51	0.80	1.29	1.82
			max. solid size [mm] ³⁾	0.5 - 1.3 (2.3)	0.7 - 2.3 (4.0)	0.9 - 3.8 (6.6)	0.9 - 4.2 (7.2)	1.1 - 6.3 (11.0)	1.2 - 8.6 (15.0)	1.2 - 9.9 (16.8)
		Cv	Cv range ⁴⁾	1.2 - 2.7 (3.7)	3.1 - 9.0 (12.5)	4.9 - 18.4 (25.5)	5.9 - 25.0 (34.8)	9.2 - 47.0 (65.5)	14.9 - 92.0 (127)	21.0 - 150.0 (208)
			Cv controlable	0.12	0.29	0.49	0.59	0.92	1.49	2.10
			max. solid size [mm] ³⁾	0.02 - 0.05 (0.09)	0.03 - 0.09 (0.16)	0.04 - 0.15 (0.26)	0.04 - 0.17 (0.28)	0.04 - 0.25 (0.43)	0.05 - 0.34 (0.59)	0.05 - 0.39 (0.66)
4 stages ¹⁾	Standard Trim xFz total = 0.985 (0.8) σ total = 1.015 (1.25) ²⁾	Kvs	Kvs range ⁴⁾	0.8 - 1.3 (2.7)	2.0 - 4.5 (9.2)	3.4 - 9.2 (18.4)	4.2 - 12.5 (25.3)	6.5 - 23.7 (46.9)	10.6 - 46.4 (92)	14.9 - 75.7 (153)
			Kv controlable	0.08	0.2	0.34	0.42	0.65	1.06	1.49
			max. solid size [mm] ³⁾	0.4 - 0.7 (2.1)	0.5 - 1.3 (3.7)	0.7 - 2.1 (6.0)	0.7 - 2.3 (6.7)	0.9 - 3.5 (10.0)	1.0 - 4.9 (13.7)	1.0 - 5.6 (15.7)
		Cv	Cv range ⁴⁾	0.9 - 1.5 (3.1)	2.3 - 5.2 (10.6)	3.9 - 10.6 (21.3)	4.9 - 14.5 (29.2)	7.5 - 27.4 (54.2)	12.3 - 53.6 (106)	17.2 - 87.5 (177)
			Cv controlable	0.09	0.23	0.39	0.49	0.75	1.23	1.72
			max. solid size [in] ³⁾	0.02 - 0.03 (0.08)	0.02 - 0.05 (0.15)	0.03 - 0.08 (0.24)	0.03 - 0.09 (0.26)	0.04 - 0.14 (0.39)	0.04 - 0.19 (0.54)	0.04 - 0.22 (0.62)
5 stages ¹⁾	Standard Trim xFz total = 0.995 (0.8) σ total = 1.005 (1.25) ²⁾	Kvs	Kvs range ⁴⁾	0.7 - 0.7 (2.3)	2.0 - 2.6 (7.7)	3.0 - 5.4 (15.8)	3.6 - 7.4 (21.6)	5.6 - 14.0 (40.6)	9.2 - 27.4 (79)	12.9 - 44.7 (129)
			Kv controlable	0.07	0.18	0.30	0.36	0.56	0.92	1.29
			max. solid size [mm] ³⁾	0.4 - 0.4 (2.0)	0.6 - 0.7 (3.4)	0.6 - 1.2 (5.6)	0.6 - 1.4 (6.2)	0.8 - 2.0 (9.4)	0.9 - 2.8 (12.8)	0.9 - 3.2 (14.5)
		Cv	Cv range ⁴⁾	0.8 - 0.8 (2.7)	2.3 - 3.0 (8.9)	3.5 - 6.2 (18.3)	4.2 - 8.6 (25.0)	6.5 - 16.2 (46.9)	10.6 - 31.7 (91)	14.9 - 51.7 (149)
			Cv controlable	0.08	0.21	0.35	0.42	0.65	1.06	1.49
			max. solid size [in] ³⁾	0.02 - 0.02 (0.08)	0.02 - 0.03 (0.13)	0.02 - 0.05 (0.22)	0.02 - 0.06 (0.24)	0.03 - 0.08 (0.37)	0.04 - 0.11 (0.50)	0.04 - 0.13 (0.57)
6 stages ¹⁾	Standard Trim xFz total = 0.998 (0.8) σ total = 1.002 (1.25) ²⁾	Kvs	Kvs range ⁴⁾	0.5 - 0.5 (1.5)	1.6 - 1.6 (5.2)	2.7 - 3.2 (12.5)	3.2 - 4.3 (17.5)	5.0 - 8.1 (33.0)	8.2 - 16.0 (63)	11.5 - 26.1 (100)
			Kv controlable	0.06	0.16	0.27	0.32	0.50	0.82	1.15
			max. solid size [mm] ³⁾	0.2 - 0.2 (1.4)	0.4 - 0.4 (2.4)	0.6 - 0.7 (4.7)	0.5 - 0.8 (4.9)	0.7 - 1.2 (8.1)	0.8 - 1.6 (10.7)	0.8 - 1.9 (11.8)
		Cv	Cv range ⁴⁾	0.5 - 0.5 (1.7)	1.8 - 1.8 (6.0)	3.1 - 3.7 (14.5)	3.7 - 5.0 (20.2)	5.8 - 9.4 (38.1)	9.5 - 18.5 (73)	13.3 - 30.2 (116)
			Cv controlable	0.07	0.18	0.31	0.37	0.58	0.95	1.33
			max. solid size [in] ³⁾	0.01 - 0.01 (0.06)	0.02 - 0.02 (0.09)	0.02 - 0.03 (0.19)	0.02 - 0.03 (0.19)	0.03 - 0.05 (0.32)	0.03 - 0.06 (0.42)	0.03 - 0.07 (0.46)

In accordance with ISA / ASME RP-75.23

1) Variable stages (without fix nozzle as last stage)

2) For total pressure drop ratio up to xF total or down to σ total: without cavitation

3) At 100% stroke

4) Maximum Cv is associated to σ total. Please consult Flowserve Essen for higher needed Cv.

- Standard Trim:** Optimized for medium with high Delta P and solids.
- First Stage two Notches:** For vibrating services the notch design provides additional guiding in the first stage
- Flow Optimized Trim:** Optimized for flow capacity and reduced erosion. A reduced xFz (= higher Sigma) per stage gives more flow and larger gaps for solids.
- First Stage On-Off:** For Soft Seat applications and more flow capacity

First Stage two Notches

Trim Design		DN	25	40/50	65	80	100	150	200	
		Stroke [mm]	10	15	20	25	40	60	60	
3 stages ¹⁾	1. Stage two Notches xFz total = 0.985 (0.8) σ total =1.045 (1.25) ²⁾	Kvs	Kvs range ⁴⁾	1.0 - 2.3 (3.2)	2.7 - 7.8 (10.8)	4.2 - 15.9 (22.1)	5.1 - 21.6 (30.1)	8.0 - 40.7 (56.7)	12.9 - 79.6 (110)	18.2 - 129.8 (180)
			Kv controlable	0.1	0.25	0.42	0.51	0.80	1.29	1.82
			max. solid size [mm] ³⁾	1.3 - 3.4 (3.3)	1.8 - 6.1 (6.0)	2.3 - 9.2 (10.5)	2.3 - 10.5 (11.4)	2.7 - 14.9 (17.5)	3.1 - 20.7 (23.8)	3.1 - 25.4 (25.4)
		Cv	Cv range ⁴⁾	1.2 - 2.7 (3.7)	3.1 - 9.0 (12.5)	4.9 - 18.4 (25.5)	5.9 - 25.0 (34.8)	9.2 - 47.0 (65.5)	14.9 - 92.0 (127)	21.0 - 150.0 (208)
			Cv controlable	0.12	0.29	0.49	0.59	0.92	1.49	2.10
			max. solid size [in] ³⁾	0.05 - 0.13 (0.13)	0.07 - 0.24 (0.24)	0.09 - 0.36 (0.41)	0.09 - 0.41 (0.45)	0.11 - 0.59 (0.69)	0.12 - 0.81 (0.94)	0.12 - 1.00 (1.00)
4 stages ¹⁾	1. Stage two Notches xFz total = 0.985 (0.8) σ total =1.015 (1.25) ²⁾	Kvs	Kvs range ⁴⁾	0.8 - 1.3 (2.7)	2.0 - 4.5 (9.2)	3.4 - 9.2 (18.4)	4.2 - 12.5 (25.3)	6.5 - 23.7 (46.9)	10.6 - 46.4 (92)	14.9 - 75.7 (153)
			Kv controlable	0.08	0.2	0.34	0.42	0.65	1.06	1.49
			max. solid size [mm] ³⁾	1.6 - 2.3 (3.3)	2.4 - 4.2 (6.1)	3.2 - 6.3 (10.5)	3.3 - 7.2 (11.6)	3.9 - 10.3 (17.2)	4.4 - 14.3 (23.6)	4.4 - 17.6 (25.9)
		Cv	Cv range ⁴⁾	0.9 - 1.5 (3.1)	2.3 - 5.2 (10.6)	3.9 - 10.6 (21.3)	4.9 - 14.5 (29.2)	7.5 - 27.4 (54.2)	12.3 - 53.6 (106)	17.2 - 87.5 (177)
			Cv controlable	0.09	0.23	0.39	0.49	0.75	1.23	1.72
			max. solid size [in] ³⁾	0.06 - 0.09 (0.13)	0.09 - 0.17 (0.24)	0.13 - 0.25 (0.41)	0.13 - 0.28 (0.46)	0.15 - 0.41 (0.68)	0.17 - 0.56 (0.93)	0.17 - 0.69 (1.02)
5 stages ¹⁾	1. Stage two Notches xFz total = 0.995 (0.8) σ total =1.005 (1.25) ²⁾	Kvs	Kvs range ⁴⁾	0.7 - 0.7 (2.3)	2.0 - 2.6 (7.7)	3.0 - 5.4 (15.8)	3.6 - 7.4 (21.6)	5.6 - 14.0 (40.6)	9.2 - 27.4 (79)	12.9 - 44.7 (129)
			Kv controlable	0.07	0.18	0.30	0.36	0.56	0.92	1.29
			max. solid size [mm] ³⁾	1.5 - 1.5 (3.2)	2.5 - 3.0 (5.8)	3.0 - 4.4 (10.2)	3.1 - 5.1 (11.1)	3.9 - 7.2 (17.0)	4.8 - 10.0 (23.1)	5.4 - 12.4 (24.8)
		Cv	Cv range ⁴⁾	0.8 - 0.8 (2.7)	2.3 - 3.0 (8.9)	3.5 - 6.2 (18.3)	4.2 - 8.6 (25.0)	6.5 - 16.2 (46.9)	10.6 - 31.7 (91)	14.9 - 51.7 (149)
			Cv controlable	0.08	0.21	0.35	0.42	0.65	1.06	1.49
			max. solid size [in] ³⁾	0.06 - 0.06 (0.13)	0.10 - 0.12 (0.23)	0.12 - 0.17 (0.40)	0.12 - 0.20 (0.44)	0.15 - 0.28 (0.67)	0.19 - 0.39 (0.91)	0.21 - 0.49 (0.98)
6 stages ¹⁾	1. Stage two Notches xFz total = 0.998 (0.8) σ total =1.002 (1.25) ²⁾	Kvs	Kvs range ⁴⁾	0.5 - 0.5 (1.5)	1.6 - 1.6 (5.2)	2.7 - 3.2 (12.5)	3.2 - 4.3 (17.5)	5.0 - 8.1 (33.0)	8.2 - 16.0 (63)	11.5 - 26.1 (100)
			Kv controlable	0.06	0.16	0.27	0.32	0.50	0.82	1.15
			max. solid size [mm] ³⁾	1.1 - 1.1 (2.2)	2.1 - 2.1 (4.1)	2.8 - 3.1 (8.5)	2.9 - 3.6 (9.7)	3.6 - 5.0 (14.6)	4.5 - 7.0 (19.3)	5.0 - 8.7 (20.4)
		Cv	Cv range ⁴⁾	0.5 - 0.5 (1.7)	1.8 - 1.8 (6.0)	3.1 - 3.7 (14.5)	3.7 - 5.0 (20.2)	5.8 - 9.4 (38.1)	9.5 - 18.5 (73)	13.3 - 30.2 (116)
			Cv controlable	0.07	0.18	0.31	0.37	0.58	0.95	1.33
			max. solid size [in] ³⁾	0.04 - 0.04 (0.09)	0.08 - 0.08 (0.16)	0.11 - 0.12 (0.33)	0.11 - 0.14 (0.38)	0.14 - 0.20 (0.57)	0.18 - 0.28 (0.76)	0.20 - 0.34 (0.80)

In accordance with ISA / ASME RP-75.23

- 1) Variable stages (without fix nozzle as last stage)
- 2) For total pressure drop ratio up to xFz total or down to σ total: without cavitation
- 3) At 100% stroke
- 4) Maximum Cv is associated to σ total. Please consult Flowserve Essen for higher needed Cv.

Flow Optimized Trim

		DN	25	40/50	65	80	100	150	200	
Trim Design		Stroke [mm]	10	15	20	25	40	60	60	
3 stages ¹⁾	Flow Optimized Trim xFz total = 0.95 (0.9) σ total = 1.052(1.111) ²⁾	Kvs	Kvs range ⁴⁾	1.0 - 2.5 (3.5)	2.7 - 8.4 (12.0)	4.2 - 17.1 (23.6)	5.1 - 23.4 (32.7)	8.0 - 44.0 (60.0)	12.9 - 86.2 (118)	18.2 - 140.0 (198)
			Kv controlable	0.1	0.25	0.42	0.51	0.80	1.29	1.82
			max. solid size [mm] ³⁾	0.5 - 1.5 (3.3)	0.8 - 2.7 (6.2)	0.9 - 4.4 (10.4)	0.9 - 4.8 (11.6)	1.2 - 7.3 (17.0)	1.3 - 9.9 (23.4)	1.3 - 11.3 (26.1)
		Cv	Cv range ⁴⁾	1.2 - 2.9 (4.0)	3.1 - 9.7 (13.9)	4.9 - 19.8 (27.3)	5.9 - 27.1 (37.8)	9.2 - 50.9 (69.4)	14.9 - 99.6 (136)	21.0 - 161.8 (229)
			Cv controlable	0.12	0.29	0.49	0.59	0.92	1.49	2.10
			max. solid size [in] ³⁾	0.02 - 0.06 (0.13)	0.03 - 0.11 (0.24)	0.04 - 0.17 (0.41)	0.04 - 0.19 (0.46)	0.05 - 0.29 (0.67)	0.05 - 0.39 (0.92)	0.05 - 0.44 (1.03)
4 stages ¹⁾	Flow Optimized Trim xFz total = 0.98 (0.96) σ total = 1.020(1.042) ²⁾	Kvs	Kvs range ⁴⁾	0.8 - 1.5 (1.5)	2.0 - 5.2 (5.2)	3.4 - 10.7 (12.5)	4.2 - 14.5 (17.5)	6.5 - 27.4 (33.0)	10.6 - 53.7 (63)	14.9 - 87.6 (100)
			Kv controlable	0.08	0.2	0.34	0.42	0.65	1.06	1.49
			max. solid size [mm] ³⁾	0.5 - 1.0 (2.2)	0.6 - 1.7 (4.1)	0.8 - 2.8 (7.8)	0.8 - 3.1 (9.1)	1.0 - 4.6 (12.9)	1.1 - 6.3 (17.6)	1.1 - 7.3 (20.3)
		Cv	Cv range ⁴⁾	0.9 - 1.7 (1.7)	2.3 - 6.0 (6.0)	3.9 - 12.4 (14.5)	4.9 - 16.8 (20.2)	7.5 - 31.7 (38.1)	12.3 - 62.1 (73)	17.2 - 101.3 (116)
			Cv controlable	0.09	0.23	0.39	0.49	0.75	1.23	1.72
			max. solid size [in] ³⁾	0.02 - 0.04 (0.09)	0.02 - 0.07 (0.16)	0.03 - 0.11 (0.31)	0.03 - 0.12 (0.36)	0.04 - 0.18 (0.51)	0.04 - 0.25 (0.69)	0.04 - 0.29 (0.80)
5 stages ¹⁾	Flow Optimized Trim xFz total = 0.99 σ total = 1.010 ²⁾	Kvs	Kvs range ⁴⁾	0.7 - 1.1	2.0 - 3.7	3.0 - 7.5	3.6 - 10.2	5.6 - 19.3	9.2 - 37.7	12.9 - 61.6
			Kv controlable	0.07	0.18	0.30	0.36	0.56	0.92	1.29
			max. solid size [mm] ³⁾	0.5 - 0.9	0.8 - 1.5	0.9 - 2.4	0.9 - 2.7	1.1 - 4.1	1.3 - 5.6	1.3 - 6.4
		Cv	Cv range ⁴⁾	0.8 - 1.3	2.3 - 4.3	3.5 - 8.7	4.2 - 11.8	6.5 - 22.3	10.6 - 43.6	14.9 - 71.2
			Cv controlable	0.08	0.21	0.35	0.42	0.65	1.06	1.49
			max. solid size [in] ³⁾	0.02 - 0.04	0.03 - 0.06	0.04 - 0.09	0.04 - 0.11	0.04 - 0.16	0.05 - 0.22	0.05 - 0.25
6 stages ¹⁾	N.A.	Kvs	Kvs range ⁴⁾	N.A.	N.A.	N.A.	N.A.	N.A.	N.A.	N.A.
			Kv controlable	N.A.	N.A.	N.A.	N.A.	N.A.	N.A.	N.A.
			max. solid size [mm] ³⁾	N.A.	N.A.	N.A.	N.A.	N.A.	N.A.	N.A.
		Cv	Cv range ⁴⁾	N.A.	N.A.	N.A.	N.A.	N.A.	N.A.	N.A.
			Cv controlable	N.A.	N.A.	N.A.	N.A.	N.A.	N.A.	N.A.
			max. solid size [in] ³⁾	N.A.	N.A.	N.A.	N.A.	N.A.	N.A.	N.A.

In accordance with ISA / ASME RP-75.23

1) Variable stages (without fix nozzle as last stage)

2) For total pressure drop ratio up to xF total or down to σ total: without cavitation

3) At 100% stroke

4) Maximum Cv is associated to σ total. Please consult Flowserve Essen for higher needed Cv.

First Stage On-Off

		DN	25	40/50	65	80	100	150	200	
Trim Design		Stroke [mm]	10	15	20	25	40	60	60	
3 stages ¹⁾	1. Stage On-Off xFz total = 0.878 (0.8) σ total = 1.139 (1.25) ²⁾	Kvs	Kvs range ⁴⁾	1.0 - 3.5 (3.8)	2.6 - 11.9 (12.8)	4.2 - 23.6 (26.1)	5.1 - 32.7 (35.6)	8.0 - 60.0 (66.9)	12.9 - 118.0 (131)	18.2 - 198.0 (213)
			Kv controlable	0.1	0.25	0.42	0.51	0.80	1.29	1.82
			max. solid size [mm] ³⁾	1.0 - 3.2 (3.3)	1.0 - 5.8 (6.1)	1.2 - 10.2 (10.7)	1.2 - 11.1 (11.3)	1.5 - 16.9 (18.3)	1.7 - 23.0 (24.4)	1.7 - 24.7 (24.6)
		Cv	Cv range ⁴⁾	1.2 - 4.0 (4.4)	3.0 - 13.8 (14.8)	4.9 - 27.3 (30.2)	5.9 - 37.8 (41.2)	9.2 - 69.4 (77.3)	14.9 - 136.4 (151)	21.0 - 228.9 (246)
			Cv controlable	0.12	0.29	0.49	0.59	0.92	1.49	2.10
			max. solid size [in] ³⁾	0.04 - 0.13 (0.13)	0.04 - 0.23 (0.24)	0.05 - 0.40 (0.42)	0.05 - 0.44 (0.44)	0.06 - 0.67 (0.72)	0.07 - 0.91 (0.96)	0.07 - 0.97 (0.97)
4 stages ¹⁾	1. Stage On-Off xFz total = 0.957 (0.8) σ total = 1.045 (1.25) ²⁾	Kvs	Kvs range ⁴⁾	0.8 - 1.5 (3.0)	2.0 - 5.2 (10.3)	3.4 - 12.5 (20.5)	4.2 - 17.5 (28.3)	6.5 - 33.0 (52.3)	10.6 - 63.0 (102)	14.9 - 100.0 (171)
			Kv controlable	0.08	0.2	0.34	0.42	0.65	1.06	1.49
			max. solid size [mm] ³⁾	1.0 - 2.2 (3.3)	1.3 - 4.0 (6.0)	1.8 - 7.7 (10.5)	1.8 - 9.1 (11.4)	2.2 - 12.8 (17.5)	2.5 - 17.5 (23.8)	2.5 - 19.9 (25.4)
		Cv	Cv range ⁴⁾	0.9 - 1.7 (3.5)	2.3 - 6.0 (11.9)	3.9 - 14.5 (23.7)	4.9 - 20.2 (32.7)	7.5 - 38.1 (60.5)	12.3 - 72.8 (118)	17.2 - 115.6 (198)
			Cv controlable	0.09	0.23	0.39	0.49	0.75	1.23	1.72
			max. solid size [in] ³⁾	0.04 - 0.09 (0.13)	0.05 - 0.16 (0.24)	0.07 - 0.30 (0.41)	0.07 - 0.36 (0.45)	0.09 - 0.50 (0.69)	0.10 - 0.69 (0.94)	0.10 - 0.78 (1.00)
5 stages ¹⁾	1. Stage On-Off xFz total = 0.985 (0.8) σ total = 1.015 (1.25) ²⁾	Kvs	Kvs range ⁴⁾	0.7 - 1.3 (2.5)	2.0 - 4.4 (8.4)	3.0 - 7.5 (17.6)	3.6 - 12.4 (24.0)	5.6 - 23.3 (45.2)	9.2 - 37.7 (88)	12.9 - 61.6 (144)
			Kv controlable	0.07	0.18	0.30	0.36	0.56	0.92	1.29
			max. solid size [mm] ³⁾	1.4 - 2.2 (3.3)	2.4 - 4.2 (5.7)	2.9 - 5.4 (10.6)	2.8 - 7.2 (11.4)	3.3 - 10.1 (17.9)	3.8 - 12.3 (24.1)	3.7 - 15.1 (25.2)
		Cv	Cv range ⁴⁾	0.8 - 1.5 (2.9)	2.3 - 5.1 (9.7)	3.5 - 8.7 (20.3)	4.2 - 14.3 (27.7)	6.5 - 26.9 (52.3)	10.6 - 43.6 (102)	14.9 - 71.2 (166)
			Cv controlable	0.08	0.21	0.35	0.42	0.65	1.06	1.49
			max. solid size [in] ³⁾	0.06 - 0.09 (0.13)	0.09 - 0.17 (0.22)	0.11 - 0.21 (0.42)	0.11 - 0.28 (0.45)	0.13 - 0.40 (0.70)	0.15 - 0.48 (0.95)	0.15 - 0.59 (0.99)
6 stages ¹⁾	1. Stage On-Off xFz total = 0.995 (0.8) σ total = 1.005 (1.25) ²⁾	Kvs	Kvs range ⁴⁾	0.5 - 0.7 (2.3)	1.6 - 2.6 (7.7)	2.7 - 5.4 (15.8)	3.2 - 7.4 (21.6)	5.0 - 13.9 (40.6)	8.2 - 27.2 (79)	11.5 - 44.5 (129)
			Kv controlable	0.06	0.16	0.27	0.32	0.50	0.82	1.15
			max. solid size [mm] ³⁾	1.1 - 1.5 (3.3)	2.0 - 2.9 (6.1)	2.7 - 4.4 (10.9)	2.9 - 5.0 (11.7)	3.5 - 7.1 (18.3)	4.4 - 9.9 (24.7)	4.9 - 12.2 (25.8)
		Cv	Cv range ⁴⁾	0.5 - 0.8 (2.7)	1.8 - 3.0 (8.9)	3.1 - 6.2 (18.3)	3.7 - 8.6 (25.0)	5.8 - 16.1 (46.9)	9.5 - 31.4 (91)	13.3 - 51.4 (149)
			Cv controlable	0.07	0.18	0.31	0.37	0.58	0.95	1.33
			max. solid size [in] ³⁾	0.04 - 0.06 (0.13)	0.08 - 0.11 (0.24)	0.11 - 0.17 (0.43)	0.11 - 0.20 (0.46)	0.14 - 0.28 (0.72)	0.17 - 0.39 (0.97)	0.19 - 0.48 (1.02)

In accordance with ISA / ASME RP-75.23

1) Variable stages (without fix nozzle as last stage)

2) For total pressure drop ratio up to xF total or down to σ total: without cavitation

3) At 100% stroke

4) Maximum Cv is associated to σ total. Please consult Flowserve Essen for higher needed Cv.

**Multi-Z valve max. Δp and according max. C_v -Values
(for water 20 °C / 68 °F)***

p1* bar a (psi a)	Δp max bar (psi) for Multi-Z Valve									
	No. of stages									
	3	3	3	3	3	3	4	4	5	6
Xf	0.75	0.8	0.85	0.9	0.92	0.95	0.975	0.985	0.9947	0.9982
400 (5800)	300 (4350)	320 (4640)	340 (4930)	360 (5220)	368 (5336)	380 (5510)	390 (5655)	394 (5713)	398 (5769)	399 (5790)
390 (5655)	293 (4241)	312 (4524)	332 (4807)	351 (5090)	359 (5203)	371 (5372)	380 (5514)	384 (5570)	388 (5625)	389 (5645)
380 (5510)	285 (4133)	304 (4408)	323 (4684)	342 (4959)	350 (5069)	361 (5235)	371 (5372)	374 (5427)	378 (5481)	379 (5500)
370 (5365)	278 (4024)	296 (4292)	315 (4560)	333 (4829)	340 (4936)	352 (5097)	361 (5231)	364 (5285)	368 (5337)	369 (5355)
360 (5220)	270 (3915)	288 (4176)	306 (4437)	324 (4698)	331 (4802)	342 (4959)	351 (5090)	355 (5142)	358 (5192)	359 (5211)
350 (5075)	263 (3806)	280 (4060)	298 (4314)	315 (4568)	322 (4669)	333 (4821)	341 (4948)	345 (4999)	348 (5048)	349 (5066)
340 (4930)	255 (3698)	272 (3944)	289 (4191)	306 (4437)	313 (4536)	323 (4684)	332 (4807)	335 (4856)	338 (4904)	339 (4921)
330 (4785)	248 (3589)	264 (3828)	281 (4067)	297 (4307)	304 (4402)	314 (4546)	322 (4665)	325 (4713)	328 (4760)	329 (4776)
320 (4640)	240 (3480)	256 (3712)	272 (3944)	288 (4176)	294 (4269)	304 (4408)	312 (4524)	315 (4570)	318 (4615)	319 (4632)
310 (4495)	233 (3371)	248 (3596)	264 (3821)	279 (4046)	285 (4135)	295 (4270)	302 (4383)	305 (4428)	308 (4471)	309 (4487)
300 (4350)	225 (3263)	240 (3480)	255 (3698)	270 (3915)	276 (4002)	285 (4133)	293 (4241)	296 (4285)	298 (4327)	299 (4342)
290 (4205)	218 (3154)	232 (3364)	247 (3574)	261 (3785)	267 (3869)	276 (3995)	283 (4100)	286 (4142)	288 (4183)	289 (4197)
280 (4060)	210 (3045)	224 (3248)	238 (3451)	252 (3654)	258 (3735)	266 (3857)	273 (3959)	276 (3999)	279 (4038)	279 (4053)
270 (3915)	203 (2936)	216 (3132)	230 (3328)	243 (3524)	248 (3602)	257 (3719)	263 (3817)	266 (3856)	269 (3894)	270 (3908)
260 (3770)	195 (2828)	208 (3016)	221 (3205)	234 (3393)	239 (3468)	247 (3582)	254 (3676)	256 (3713)	259 (3750)	260 (3763)
250 (3625)	188 (2719)	200 (2900)	213 (3081)	225 (3263)	230 (3335)	238 (3444)	244 (3534)	246 (3571)	249 (3606)	250 (3618)
240 (3480)	180 (2610)	192 (2784)	204 (2958)	216 (3132)	221 (3202)	228 (3306)	234 (3393)	236 (3428)	239 (3462)	240 (3474)
230 (3335)	173 (2501)	184 (2668)	196 (2835)	207 (3002)	212 (3068)	219 (3168)	224 (3252)	227 (3285)	229 (3317)	230 (3329)
220 (3190)	165 (2393)	176 (2552)	187 (2712)	198 (2871)	202 (2935)	209 (3031)	215 (3110)	217 (3142)	219 (3173)	220 (3184)
210 (3045)	158 (2284)	168 (2436)	179 (2588)	189 (2741)	193 (2801)	200 (2893)	205 (2969)	207 (2999)	209 (3029)	210 (3040)
200 (2900)	150 (2175)	160 (2320)	170 (2465)	180 (2610)	184 (2668)	190 (2755)	195 (2828)	197 (2857)	199 (2885)	200 (2895)
190 (2755)	143 (2066)	152 (2204)	162 (2342)	171 (2480)	175 (2535)	181 (2617)	185 (2686)	187 (2714)	189 (2740)	190 (2750)
180 (2610)	135 (1958)	144 (2088)	153 (2219)	162 (2349)	166 (2401)	171 (2480)	176 (2545)	177 (2571)	179 (2596)	180 (2605)
170 (2465)	128 (1849)	136 (1972)	145 (2095)	153 (2219)	156 (2268)	162 (2342)	166 (2403)	167 (2428)	169 (2452)	170 (2461)
160 (2320)	120 (1740)	128 (1856)	136 (1972)	144 (2088)	147 (2134)	152 (2204)	156 (2262)	158 (2285)	159 (2308)	160 (2316)
150 (2175)	113 (1631)	120 (1740)	128 (1849)	135 (1958)	138 (2001)	143 (2066)	146 (2121)	148 (2142)	149 (2163)	150 (2171)
140 (2030)	105 (1523)	112 (1624)	119 (1726)	126 (1827)	129 (1868)	133 (1929)	137 (1979)	138 (2000)	139 (2019)	140 (2026)
130 (1885)	98 (1414)	104 (1508)	111 (1602)	117 (1697)	120 (1734)	124 (1791)	127 (1838)	128 (1857)	129 (1875)	130 (1882)
120 (1740)	90 (1305)	96 (1392)	102 (1479)	108 (1566)	110 (1601)	114 (1653)	117 (1697)	118 (1714)	119 (1731)	120 (1737)
110,0 (1595)	82,5 (1196)	88,0 (1276)	93,5 (1356)	99,0 (1436)	101,2 (1467)	104,5 (1515)	107,3 (1555)	108,4 (1571)	109,4 (1587)	109,8 (1592)
100,0 (1450)	75,0 (1088)	80,0 (1160)	85,0 (1233)	90,0 (1305)	92,0 (1334)	95,0 (1378)	97,5 (1414)	98,5 (1428)	99,5 (1442)	99,8 (1447)
90,0 (1305)	67,5 (979)	72,0 (1044)	76,5 (1109)	81,0 (1175)	82,8 (1201)	85,5 (1240)	87,8 (1272)	88,7 (1285)	89,5 (1298)	89,8 (1303)
80,0 (1160)	60,0 (870)	64,0 (928)	68,0 (986)	72,0 (1044)	73,6 (1067)	76,0 (1102)	78,0 (1131)	78,8 (1143)	79,6 (1154)	79,9 (1158)
70,0 (1015)	52,5 (761)	56,0 (812)	59,5 (863)	63,0 (914)	64,4 (934)	66,5 (964)	68,3 (990)	69,0 (1000)	69,6 (1010)	69,9 (1013)
60,0 (870)	45,0 (653)	48,0 (696)	51,0 (740)	54,0 (783)	55,2 (800)	57,0 (827)	58,5 (848)	59,1 (857)	59,7 (865)	59,9 (868)
50,0 (725)	37,5 (544)	40,0 (580)	42,5 (616)	45,0 (653)	46,0 (667)	47,5 (689)	48,8 (707)	49,3 (714)	49,7 (721)	49,9 (724)
40,0 (580)	30,0 (435)	32,0 (464)	34,0 (493)	36,0 (522)	36,8 (534)	38,0 (551)	39,0 (566)	39,4 (571)	39,8 (577)	39,9 (579)
30,0 (435)	22,5 (326)	24,0 (348)	25,5 (370)	27,0 (392)	27,6 (400)	28,5 (413)	29,3 (424)	29,6 (428)	29,8 (433)	29,9 (434)
20,0 (290)	15,0 (218)	16,0 (232)	17,0 (247)	18,0 (261)	18,4 (267)	19,0 (276)	19,5 (283)	19,7 (286)	19,9 (288)	20,0 (289)
10,0 (145)	7,5 (109)	8,0 (116)	8,5 (123)	9,0 (131)	9,2 (133)	9,5 (138)	9,8 (141)	9,9 (143)	9,9 (144)	10,0 (145)

p1 = Inlet pressure*

Valve size	Max. C_v -values for Multi-Z Valve									
	No. of stages									
	3	3	3	3	3	3	4	4	5	6
1"	4.0	3.7	3.5	3.2	3.1	2.7	1.8	1.5	0.8	0.53
1.5"	12.5	12.5	11.9	11.1	9.7	9.0	6.0	5.2	3.0	1.8
2"	12.5	12.5	11.9	11.1	9.7	9.0	6.0	5.2	3.0	1.8
2.5"	27.3	25.5	23.8	22.5	21.3	18.4	12.4	10.6	6.2	3.7
3"	37.9	34.8	32.8	30.7	29.4	25.0	16.9	14.5	8.6	5.0
4"	69.5	65.5	60.5	57.8	54.2	47.0	31.7	27.4	16.2	9.4
6"	137.0	128.2	119.1	113.2	106.7	92.0	62.1	53.6	31.7	18.5
8"	229.9	209.1	198.4	184.5	166.9	150.0	101.3	87.5	51.7	30.2

Valve size	Min. controllable C_v -values for Multi-Z Valve			
	No. of stages			
	3	4	5	6
1"	0.12	0.09	0.08	0.07
1.5"	0.29	0.23	0.21	0.18
2"	0.29	0.23	0.21	0.18
2.5"	0.49	0.39	0.35	0.31
3"	0.59	0.49	0.42	0.37
4"	0.92	0.75	0.65	0.58
6"	1.49	1.23	1.06	0.95
8"	2.10	1.72	1.49	1.33

* For other medium or temperature exchange p1 by p1-pv (pv=vapour pressure of medium at service temperature)

**Multi-Z valve max. Δp and according max. K_{vs} -Values
(for water 20°C / 68 °F)***

p1* [bar a]	Δp max bar for Multi-Z Valve									
	No. of stages									
	3	3	3	3	3	3	4	4	5	6
Xf	0.75	0.8	0.85	0.9	0.92	0.95	0.975	0.985	0.9947	0.9982
400	300	320	340	360	368	380	390	394	398	399
390	293	312	332	351	359	371	380	384	388	389
380	285	304	323	342	350	361	371	374	378	379
370	278	296	315	333	340	352	361	364	368	369
360	270	288	306	324	331	342	351	355	358	359
350	263	280	298	315	322	333	341	345	348	349
340	255	272	289	306	313	323	332	335	338	339
330	248	264	281	297	304	314	322	325	328	329
320	240	256	272	288	294	304	312	315	318	319
310	233	248	264	279	285	295	302	305	308	309
300	225	240	255	270	276	285	293	296	298	300
290	218	232	247	261	267	276	283	286	288	290
280	210	224	238	252	258	266	273	276	279	280
270	203	216	230	243	248	257	263	266	269	270
260	195	208	221	234	239	247	254	256	259	260
250	188	200	213	225	230	238	244	246	249	250
240	180	192	204	216	221	228	234	236	239	240
230	173	184	196	207	212	219	224	227	229	230
220	165	176	187	198	202	209	215	217	219	220
210	158	168	179	189	193	200	205	207	209	210
200	150	160	170	180	184	190	195	197	199	200
190	143	152	162	171	175	181	185	187	189	190
180	135	144	153	162	166	171	176	177	179	180
170	128	136	145	153	156	162	166	167	169	170
160	120	128	136	144	147	152	156	158	159	160
150	113	120	128	135	138	143	146	148	149	150
140	105	112	119	126	129	133	137	138	139	140
130	98	104	111	117	120	124	127	128	129	130
120	90.0	96	102	108	110	114	117	118	119	120
110	82.5	88.0	93.5	99	101	105	107	108	109.4	110
100	75.0	80.0	85.0	90.0	92.0	95.0	97.5	98.5	99.5	100
90	67.5	72.0	76.5	81.0	82.8	85.5	87.8	88.7	89.5	90
80	60.0	64.0	68.0	72.0	73.6	76.0	78.0	78.8	79.6	80
70	52.5	56.0	59.5	63.0	64.4	66.5	68.3	69.0	69.6	70
60	45.0	48.0	51.0	54.0	55.2	57.0	58.5	59.1	59.7	60
50	37.5	40.0	42.5	45.0	46.0	47.5	48.8	49.3	49.7	50
40	30.0	32.0	34.0	36.0	36.8	38.0	39.0	39.4	39.8	40
30	22.5	24.0	25.5	27.0	27.6	28.5	29.3	29.6	29.8	30
20	15.0	16.0	17.0	18.0	18.4	19.0	19.5	19.7	19.9	20
10	7.5	8.0	8.5	9.0	9.2	9.5	9.8	9.9	9.95	10

p1 = Inlet pressure*

Valve size	Max. Kvs-values for Multi-Z Valve									
	No. of stages									
	3	3	3	3	3	3	4	4	5	6
DN 25	3.5	3.2	3	2.8	2.7	2.3	1.6	1.3	0.7	0.46
DN 40	10.8	10.8	10.3	9.6	8.4	7.8	5.2	4.5	2.6	1.6
DN 50	10.8	10.8	10.3	9.6	8.4	7.8	5.2	4.5	2.6	1.6
DN 65	23.6	22.1	20.6	19.5	18.4	15.9	10.7	9.2	5.4	3.2
DN 80	32.8	30.1	28.4	26.6	25.4	21.6	14.6	12.5	7.4	4.3
DN 100	60.1	56.7	52.3	50	46.9	40.7	27.4	23.7	14	8.1
DN 150	118.5	110.9	103	97.9	92.3	79.6	53.7	46.4	27.4	16
DN 200	198.9	180.9	171.6	159.6	144.4	129.8	87.6	75.7	44.7	26.1

Valve size	Min. controlable Kv-values for Multi-Z Valve			
	No. of stages			
	3	4	5	6
DN 25	0.10	0.08	0.07	0.06
DN 40	0.25	0.20	0.18	0.16
DN 50	0.25	0.20	0.18	0.16
DN 65	0.42	0.34	0.30	0.27
DN 80	0.51	0.42	0.36	0.32
DN 100	0.80	0.65	0.56	0.50
DN 150	1.29	1.06	0.92	0.82
DN 200	1.82	1.49	1.29	1.15

* For other medium or temperature exchange p1 by p1-pv (pv=vapour pressure of medium at service temperature)

Construction and Materials

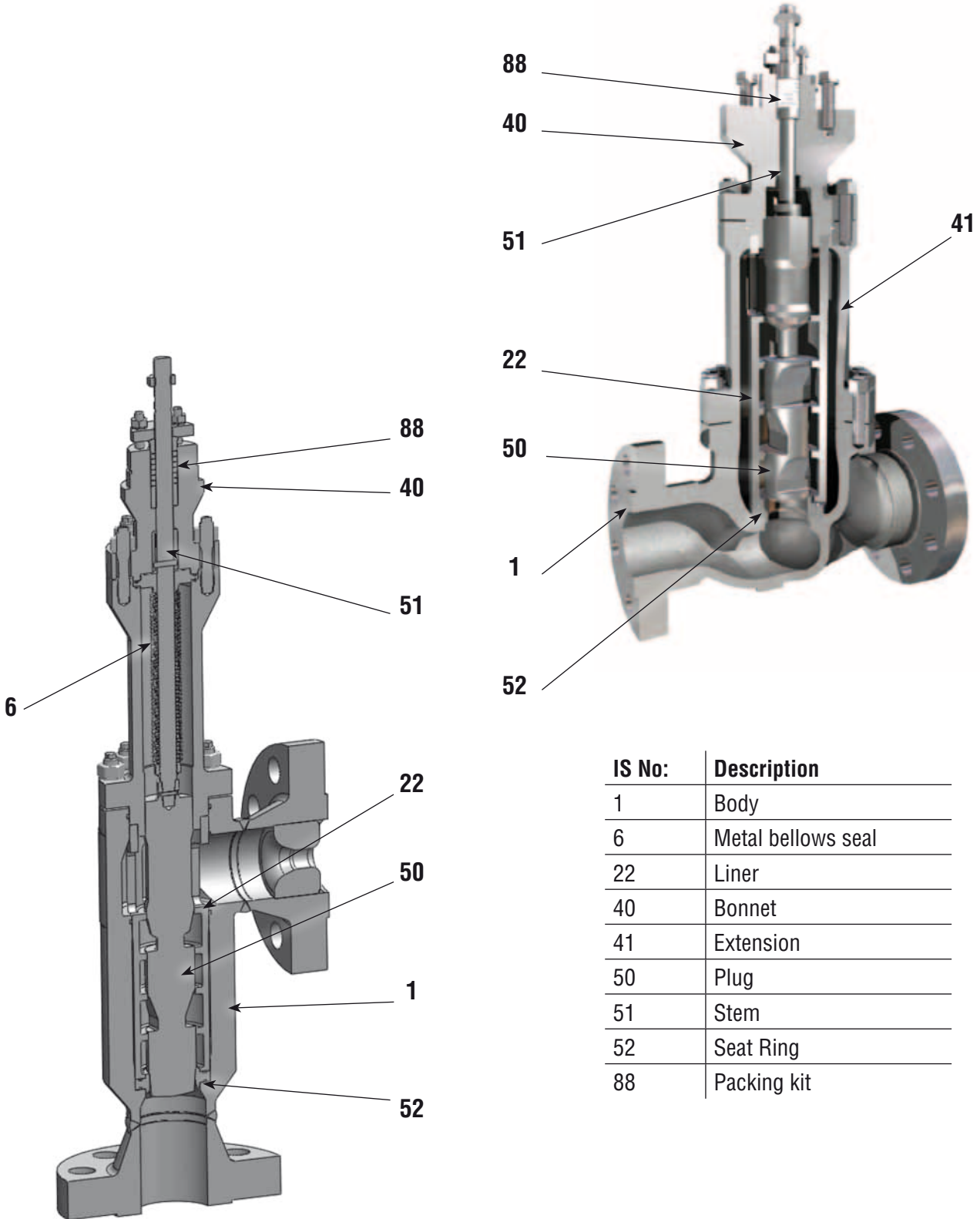

Materials of Construction

Body (1)

Materials	ANSI		
	Stainless Steel	Carbon Steel	Other
Cast	J82900 / CF8M	J03002 / WCB J02503 / WCC	
Forging / Bar stock	S31635 / 316Ti	K03504 / A105	Specials

Bonnet (40) and Extension (41)

Materials	ANSI		
	Stainless Steel	Carbon Steel	Other
	316Ti / CF8M	A105 / WCB / WCC	Specials

Trim parts

	Plug (50)	Seat (52)	Liner (22)	Stem (51)	Soft seat
Materials Standard	S44003 / 440B hardened / 1.4112 S32205 / 2205 / 1.4462 Specials			S31635 / 316Ti / 1.4571 S17400 / 17-4PH / 1.4548.4 S20910/Nitronic 50/1.4565 Specials	PTFE PCTFE Specials
Materials NACE*	S17400 / 17-4PH / 1.4548.4 Other **	S31635 / 316Ti / 1.4571 With Alloy 6 Other **	S20910 / Nitronic 50 / 1.4565 Other **	S20910 / Nitronic 50 / 1.4565 Other **	

* In accordance with MR 0103 and ISO 15156 (MR 0175) ** for other materials for NACE applications please consult Flowserve Essen

Packing (88)

	Material	Max. Pressure	Certificates	Max. Temp
Standard	PTFE	250 bar (3626 psi)	None	250 °C (480 °F)
	Graphite	250 bar (3626 psi)	None	500 °C (930 °F)
Life loaded	Sureguard HP LL	160 bar (2320 psi)	ISO 15848-1 Class B	280 °C (536 °F)
	Sureguard HP 325	325 bar (4713 psi)	TA-Luft (at max. 80 °C)	250 °C (480 °F)
	ISO C V-Ring	100 bar (1450 psi)	ISO 15848-1 Class C	170 °C (338 °F)

Metal Bellows Seal (6)

	Material	Pressure Class	Max. Temp
Standard	316	CL600 / 100bar	550 °C (1020 °F)
	Hastelloy C276	325bar	450 °C (840 °F)

Body temperature limitations

Material	Material group	Min. Temp	Max. Temp
CF8M	2.2	-29 °C (-20 °F)	400 °C (750 °F)
316SS	2.2	-29 °C (-20 °F)	400 °C (750 °F)
WCB/WCC	1.1 / 1.2	-29 °C (-20 °F)	400 °C (750 °F)
A105	1.1	-29 °C (-20 °F)	400 °C (750 °F)

Pressure balance gasket temperature limitations

	Material	Max. Temp
Standard	Turcon O-Ring supported	250 °C (480 °F)
	Metalic piston rings	400 °C (750 °F)
	V-Ring uni-direction	250 °C (480 °F)

Dimensions

Angle Valves, ANSI

Forged Body, End Connections RF/RFSF and RTJ, Kämmer Standard

Valve Size (Inch)	300#						600#					
	A	B3	B4	B5	B6	C	A	B3	B4	B5	B6	C
1							3,74	5,91	6,69	7,48	8,27	3,94
1,5							5,51	8,66	9,84	11,2	12,20	54
2							5,71	8,86	104	11,22	12,40	54
2,5							6,10	9,84	11,22	12,80	14,17	5,71
3							6,89	10,83	12,60	14,37	16,14	6,69
4							8,86	15,55	18,31	216	242	8,27

Valve Size (mm)	300#						600#					
	A	B3	B4	B5	B6	C	A	B3	B4	B5	B6	C
1							95	150	170	190	210	100
1,5							140	220	250	280	310	128
2							145	225	255	285	315	128
2,5							155	250	285	325	360	145
3							175	275	320	365	410	170
4							225	395	465	535	610	210

Globe Valves, DIN - DIN EN 558

Forged Body, End Connections EN 1092-1 B1 / B2

Valve Size (Inch)	PN40					PN63/100				
	A	C3	C4	C5	C6	A	C3	C4	C5	C6
25	6,30	---	8,15	8,15	9,02	9,06	---	8,15	8,15	9,02
40	7,87	9,17	10,35	11,54	12,72	10,24	9,17	10,35	11,54	12,72
50	9,06	9,17	10,35	11,54	12,72	11,81	9,17	10,35	11,54	12,72
65										
80	12,20	12,99	14,76	16,54	18,31	14,96	12,99	14,76	16,54	18,31
100	13,78	17,17	20,00	22,83	25,67	16,93	17,17	20,00	22,83	25,67

Valve Size (mm)	PN40					PN63/100				
	A	C3	C4	C5	C6	A	C3	C4	C5	C6
25	160,0	---	207	207	229	230	---	207	207	229
40	200,0	233	263	293	323	260	233	263	293	323
50	230,0	233	263	293	323	300	233	263	293	323
65										
80	310,0	330	375	420	465	380	330	375	420	465
100	350,0	436	508	580	652	430	436	508	580	652

All dimensions C are designed for Kämmer KP-actuators.
The use of other actuators may change the dimension Cx.

B3, C3 = valve with 3 stages

B4, C4 = valve with 4 stages

900#						1500#					
A	B3	B4	B5	B6	C	A	B3	B4	B5	B6	C
4,72	6,69	7,48	8,27	96	3,94	4,72	6,69	7,48	8,27	96	3,94
5,91	96	10,24	11,42	12,60	54	5,91	96	10,24	11,42	12,60	54
6,69	9,84	112	12,20	13,39	54	6,69	9,84	112	12,20	13,39	54
79	112	12,20	13,78	15,35	5,71	79	112	12,20	13,78	15,35	5,71
7,68	11,42	13,19	14,96	16,73	6,69	8,27	121	13,78	15,55	17,32	6,69
9,25	15,94	18,70	21,46	24,41	8,27	9,84	16,34	199	21,85	24,80	8,27

900#						1500#					
A	B3	B4	B5	B6	C	A	B3	B4	B5	B6	C
120	170	190	210	230	100	120	170	190	210	230	100
150	230	260	290	320	128	150	230	260	290	320	128
170	250	280	310	340	128	170	250	280	310	340	128
180	280	310	350	390	145	180	280	310	350	390	145
195	290	335	380	425	170	210	305	350	395	440	170
235	405	475	545	620	210	250	415	485	555	630	210

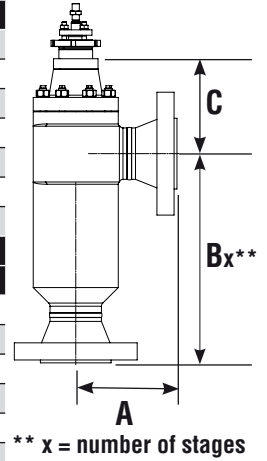

PN160					PN250				
A	C3	C4	C5	C6	A	C3	C4	C5	C6
9,06	---	8,15	8,15	9,02	10,24	---	8,15	8,15	9,02
10,24	9,17	10,35	11,54	12,72	11,81	9,17	10,35	11,54	12,72
11,81	9,17	10,35	11,54	12,72	13,78	9,17	10,35	11,54	12,72
14,96	12,99	14,76	16,54	18,31	17,72	12,99	14,76	16,54	18,31
16,93	17,17	20,00	22,83	25,67	20,47	17,17	20,00	22,83	25,67

PN160					PN250				
A	C3	C4	C5	C6	A	C3	C4	C5	C6
230	---	207	207	229	260	---	207	207	229
260	233	263	293	323	300	233	263	293	323
300	233	263	293	323	350	233	263	293	323
380	330	375	420	465	450	330	375	420	465
430	436	508	580	652	520	436	508	580	652

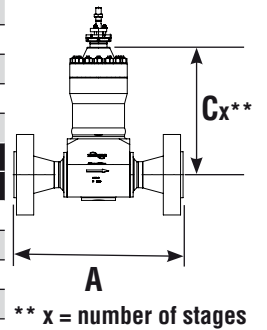

Dimensions

Globe Valves, ANSI - ANSI / ISA 75.08.01 (300 - 600#) - ANSI / ISA 75.08.06 (900 - 1500#) Forged Body, End Connections RF/RFSF

Valve Size (Inch)	300#					600#				
	A	C3	C4	C5	C6	A	C3	C4	C5	C6
1	7,76	---	8,15 *	8,15	9,02	8,27	---	8,15 *	8,15	9,02
1,5	9,25	9,17	10,35	11,54	12,72	9,88	9,17	10,35	11,54	12,72
2	10,51	9,17	10,35	11,54	12,72	11,26	9,17	10,35	11,54	12,72
2,5										
3	12,52	12,99	14,76	16,54	18,31	13,27	12,99	14,76	16,54	18,31
4	14,49	17,17	20,00	22,83	25,67	15,51	17,17	20,00	22,83	25,67

Valve Size (mm)	300#					600#				
	A	C3	C4	C5	C6	A	C3	C4	C5	C6
1	197,0	---	207 *	207	229	210	---	207 *	207	229
1,5	235,0	233	263	293	323	251	233	263	293	323
2	267,0	233	263	293	323	286	233	263	293	323
2,5										
3	318,0	330	375	420	465	337	330	375	420	465
4	368,0	436	508	580	652	394	436	508	580	652

Globe Valves, ANSI - ANSI / ISA 75.08.01 (300 - 600#) - ANSI / ISA 75.08.06 (900 - 1500#) Forged Body, End Connections RTJ

Valve Size (Inch)	300#					600#				
	A	C3	C4	C5	C6	A	C3	C4	C5	C6
1	7,76	---	8,15	8,15	9,02	8,27	---	8,15	8,15	9,02
1,5	9,25	9,17	10,35	11,54	12,72	9,88	9,17	10,35	11,54	12,72
2	10,63	9,17	10,35	11,54	12,72	11,38	9,17	10,35	11,54	12,72
2,5										
3	12,64	12,99	14,76	16,54	18,31	13,39	12,99	14,76	16,54	18,31
4	14,61	17,17	20,00	22,83	25,67	15,63	17,17	20,00	22,83	25,67

Valve Size (mm)	300#					600#				
	A	C3	C4	C5	C6	A	C3	C4	C5	C6
1	197,0	---	207	207	229	210	---	207	207	229
1,5	235,0	233	263	293	323	251	233	263	293	323
2	270,0	233	263	293	323	289	233	263	293	323
2,5										
3	321,0	330	375	420	465	340	330	375	420	465
4	371,0	436	508	580	652	397	436	508	580	652

All dimensions C are designed for Kämmer KP-actuators.
The use of other actuators may change the dimension Cx.
B3, C3 = valve with 3 stages
B4, C4 = valve with 4 stages

900#					1500#				
A	C3	C4	C5	C6	A	C3	C4	C5	C6
11,50	---	8,15 *	8,15	9,02	11,50	---	8,15 *	8,15	9,02
13,11	9,17	10,35	11,54	12,72	13,11	9,17	10,35	11,54	12,72
14,76	9,17	10,35	11,54	12,72	14,76	9,17	10,35	11,54	12,72
17,36	12,99	14,76	16,54	18,31	18,11	12,99	14,76	16,54	18,31
20,12	17,17	20,00	22,83	25,67	20,87	17,17	20,00	22,83	25,67

900#					1500#				
A	C3	C4	C5	C6	A	C3	C4	C5	C6
292	---	207 *	207	229	292	---	207 *	207	229
333	233	263	293	323	333	233	263	293	323
375	233	263	293	323	375	233	263	293	323
441	330	375	420	465	460	330	375	420	465
511	436	508	580	652	530	436	508	580	652

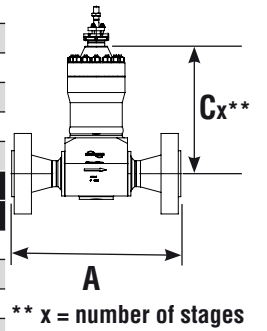

900#					1500#				
A	C3	C4	C5	C6	A	C3	C4	C5	C6
11,50	---	8,15	8,15	9,02	11,50	---	8,15	8,15	9,02
13,11	9,17	10,35	11,54	12,72	13,11	9,17	10,35	11,54	12,72
14,88	9,17	10,35	11,54	12,72	14,88	9,17	10,35	11,54	12,72
17,36	12,99	14,76	16,54	18,31	18,23	12,99	14,76	16,54	18,31
20,24	17,17	20,00	22,83	25,67	20,98	17,17	20,00	22,83	25,67

900#					1500#				
A	C3	C4	C5	C6	A	C3	C4	C5	C6
292	---	207	207	229	292	---	207	207	229
333	233	263	293	323	333	233	263	293	323
378	233	263	293	323	378	233	263	293	323
441	330	375	420	465	463	330	375	420	465
514	436	508	580	652	533	436	508	580	652

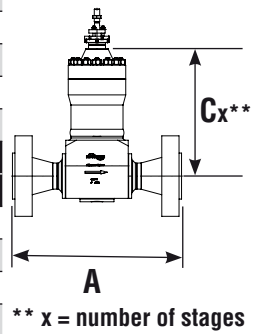

Dimensions

Globe Valves, ANSI - ANSI / ISA 75.08.01 (300 - 600#) - ANSI / ISA 75.08.06 (900 - 1500#)
 Cast Body, End Connections RF/RFSF

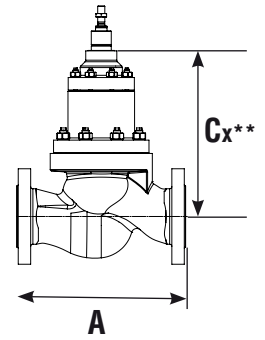

** x = number of stages

Valve Size (Inch)	600#					900#					1500#				
	A	C3	C4	C5	C6	A	C3	C4	C5	C6	A	C3	C4	C5	C6
1	8,27	---	8,15 *	8,15	9,02	11,50	---	8,15 *	8,15	9,02	11,50	---	8,15 *	8,15	9,02
1,5	9,88	9,17	10,35	11,54	12,72	13,11	9,17	10,35	11,54	12,72	13,11	9,17	10,35	11,54	12,72
2	11,26	9,17	10,35	11,54	12,72	14,76	9,17	10,35	11,54	12,72	14,76	9,17	10,35	11,54	12,72
3	13,27	12,68	14,45	16,22	17,99	17,36	12,68	14,45	16,22	17,99	18,11	12,68	14,45	16,22	17,99
4	15,51	17,44	20,28	23,11	25,94	20,12	17,44	20,28	23,11	25,94	20,87	17,44	20,28	23,11	25,94

Valve Size (mm)	600#					900#					1500#				
	A	C3	C4	C5	C6	A	C3	C4	C5	C6	A	C3	C4	C5	C6
1	210	---	207 *	207	229	292	---	207 *	207	229	292	---	207 *	207	229
1,5	251	233	263	293	323	333	233	263	293	323	333	233	263	293	323
2	286	233	263	293	323	375	233	263	293	323	375	233	263	293	323
3	337	322	367	412	457	441	322	367	412	457	460	322	367	412	457
4	394	443	515	587	659	511	443	515	587	659	530	443	515	587	659

Globe Valves, ANSI - ANSI / ISA 75.08.01 (300 - 600#) - ANSI / ISA 75.08.06 (900 - 1500#)
 Cast Body, End Connections RTJ

Valve Size (Inch)	600#					900#					1500#				
	A	C3	C4	C5	C6	A	C3	C4	C5	C6	A	C3	C4	C5	C6
1	8,27	---	8,15 *	8,15	9,02	11,50	---	8,15 *	8,15	9,02	11,50	---	8,15 *	8,15	9,02
1,5	9,88	9,17	10,35	11,54	12,72	13,11	9,17	10,35	11,54	12,72	13,11	9,17	10,35	11,54	12,72
2	11,38	9,17	10,35	11,54	12,72	14,88	9,17	10,35	11,54	12,72	14,88	9,17	10,35	11,54	12,72
3	13,39	12,68	14,45	16,22	17,99	17,36	12,68	14,45	16,22	17,99	18,23	12,68	14,45	16,22	17,99
4	15,63	17,44	20,28	23,11	25,94	20,24	17,44	20,28	23,11	25,94	20,98	17,44	20,28	23,11	25,94

Valve Size (mm)	600#					900#					1500#				
	A	C3	C4	C5	C6	A	C3	C4	C5	C6	A	C3	C4	C5	C6
1	210	---	207 *	207	229	292	---	207 *	207	229	292	---	207 *	207	229
1,5	251	233	263	293	323	333	233	263	293	323	333	233	263	293	323
2	289	233	263	293	323	378	233	263	293	323	378	233	263	293	323
3	340	322	367	412	457	441	322	367	412	457	463	322	367	412	457
4	397	443	515	587	659	514	443	515	587	659	533	443	515	587	659

All dimensions C are designed for Kämmer KP-actuators.
 The use of other actuators may change the dimension Cx.

* 5 stage ; 1st stage On/Off

Actuator mounting options

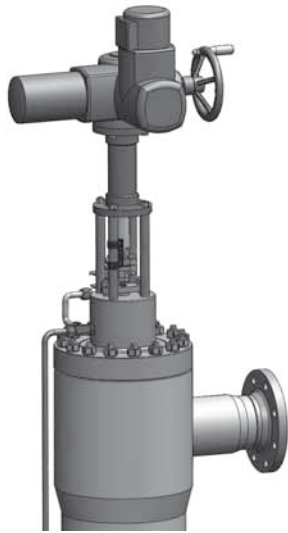

Limitorque, electric

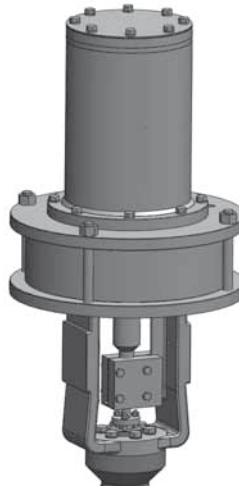

VL-ES, piston

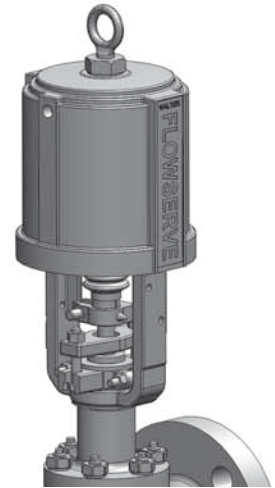

VL, piston

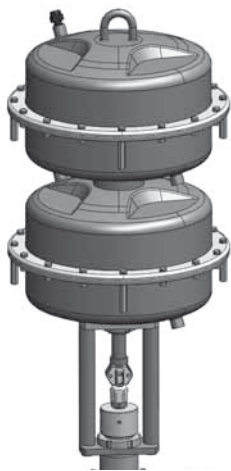

KP, diaphragm

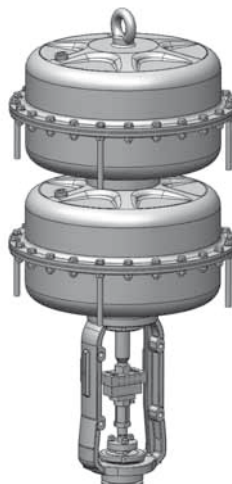

FlowAct, diaphragm

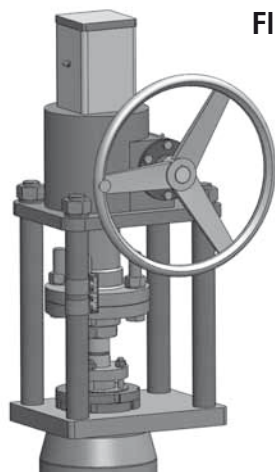

Manual

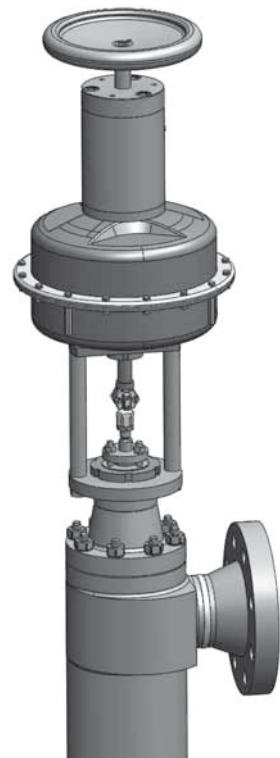

KP, (diaphragm) with Handwheel



Flowserve Essen GmbH
Schederhofstr. 71
45145 Essen
Deutschland
Tel.: +49 (0)201 8919 5
Fax: +49 (0)201 8919 662

**Flowserve FCD
Kammer Valves**
1300 Parkway View Drive
Pittsburgh, Pa 15205
USA
Tel.: +1 412 787 8803
Fax: +1 412 787 1944

**Singapur
Flowserve Pte Ltd**
12 Tuas Avenue 20
Singapore, 638824
Singapur
Tel.: +65 6879 8989
Fax: +65 6862 4940

Your contact:

A large, empty rectangular box with a dashed border, intended for a contact name or address.