

SIHI® KPH 85229

Two-Stage Liquid Ring Compressor



Proven liquid ring compressor technology

SIHI® KPH 85229 liquid ring compressors from Flowserve are designed to compress different kinds of gases and vapors. They are most commonly used in applications where safety, reliability and special process conditions are required.

SIHI liquid ring compressors are well-proven. They are able to operate under the most severe process conditions and use any type of service liquid. This feature makes SIHI liquid ring compressors unique for special applications where process contamination is prohibitive.

Benefits

- Design compliant with API 681
- Best-in-class isothermal efficiency
- Discharge connection can be selected on either right or left side
- Adjustable range of service liquid consumption
- Smallest dimensional footprint
- Integrated rotor support
- Sturdy between bearings design
- Low vibration

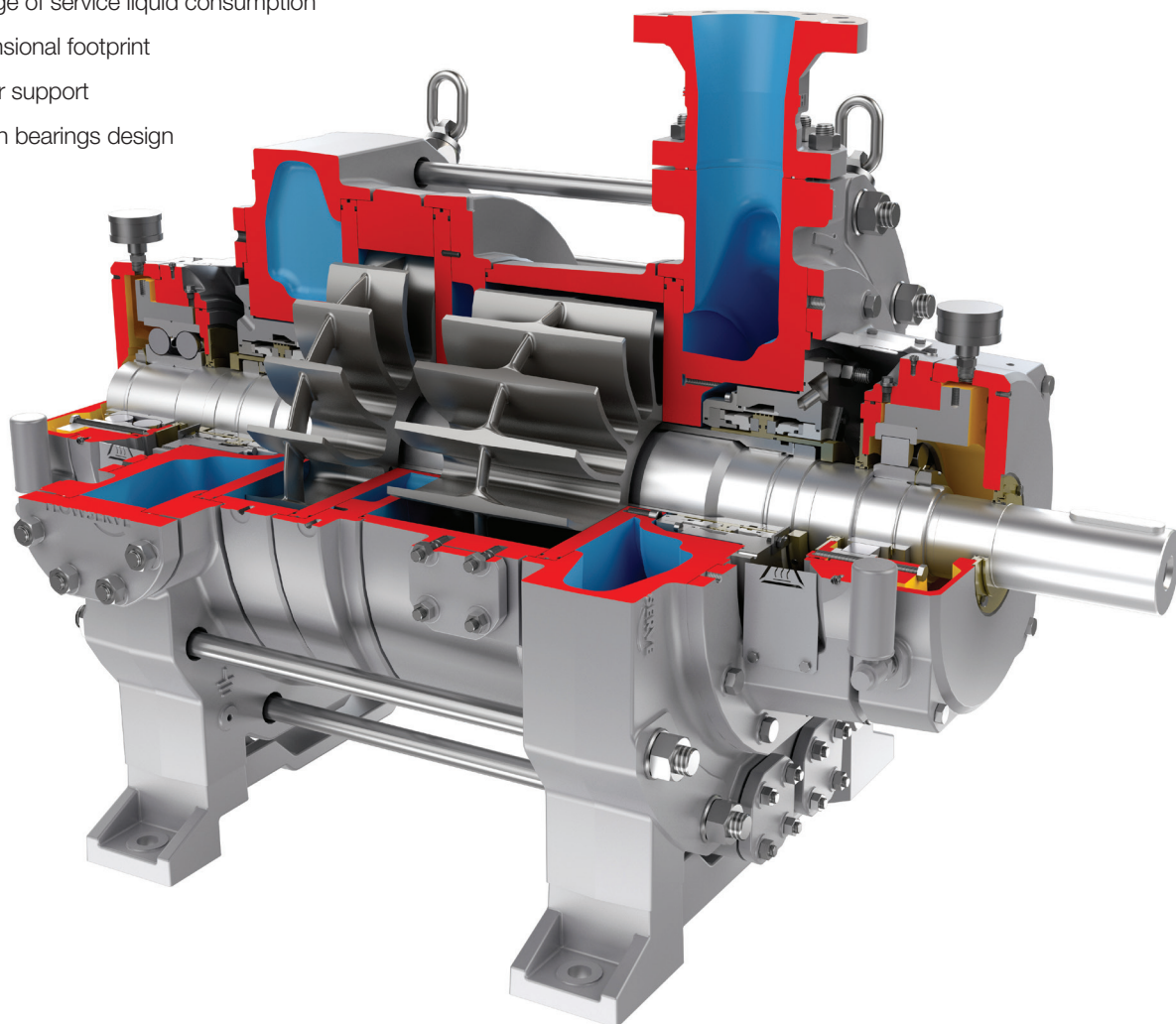

Applications

SIHI KPH 85229 two-stage liquid ring compressors are engineered to operate in applications where gas must be compressed carefully to an over-pressure up to 10 barg (145 psig) with a suction capacity up to 2,050 m³/h (1,206 cfm).

Principle industries

- Chemical — basic, biofuels and petrochemicals
- Oil and gas — downstream processing
- Power — geothermal
- Water — treatment and desalination
- Other industries

Key applications

- Flare gas recovery
- Vapor recovery
- Vinyl chloride monomer recovery
- Dry and wet chlorine compression
- Condensable gases
- Non-condensable gases
- Waste gas disposal
- Gas transfer

General technical data

Parameter		Model KPH 85229
Speed	50 Hz	985 rpm
	60 Hz	1,180 rpm
Max. compression over-pressure		10 barg (145 psig)
Hydrostatic pressure test (over-pressure)		18 barg (261 psig)
Moment of inertia of the rotating pump parts and of the water filling		9.93 kg m ² (235.6 lb ft ²)
Average sound pressure level in 1 m (3.3 ft) distance		≤ 84 dB (A) ¹
Max. gas inlet temperature		100°C (212°F)
Services liquid volume up to shaft level		101 dm ³ (3.57 ft ³)

¹ According to DIN EN ISO 2151 applying DIN ISO 9614-2 and ISO 11203

Sectional drawing and material design

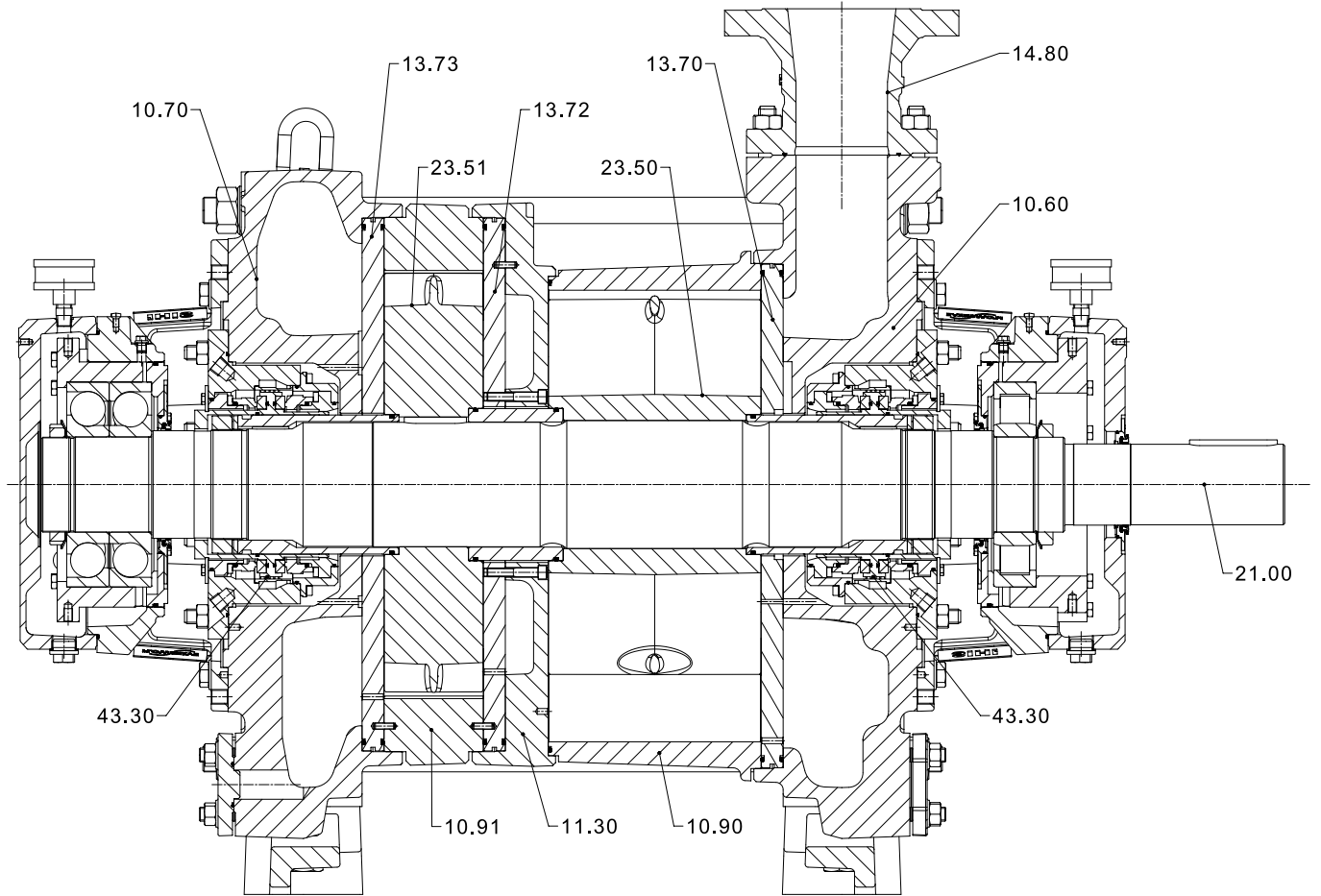

Materials of construction

Item	Component	Standard Material Design
10.60/10.70	Suction/Discharge casing	ASTM A351 CF3M
10.90/10.91	Central body	ASTM A351 CF3M
11.30	Intermediate piece	ASTM A351 CF3M
13.70/13.72/13.73	Guide disc	ASTM A240 316L
14.80	Flange connection	ASTM A351 CF3M
21.00	Shaft	ASTM A276, Type 420
23.50/23.51	Vane wheel impeller	ASTM A890 Grade 4A
53.10	Clamping sleeve	ASTM A276 UNS S31803
43.30	Mechanical seal	Flowserve HSH/HSH

Suction volume flow and power absorption

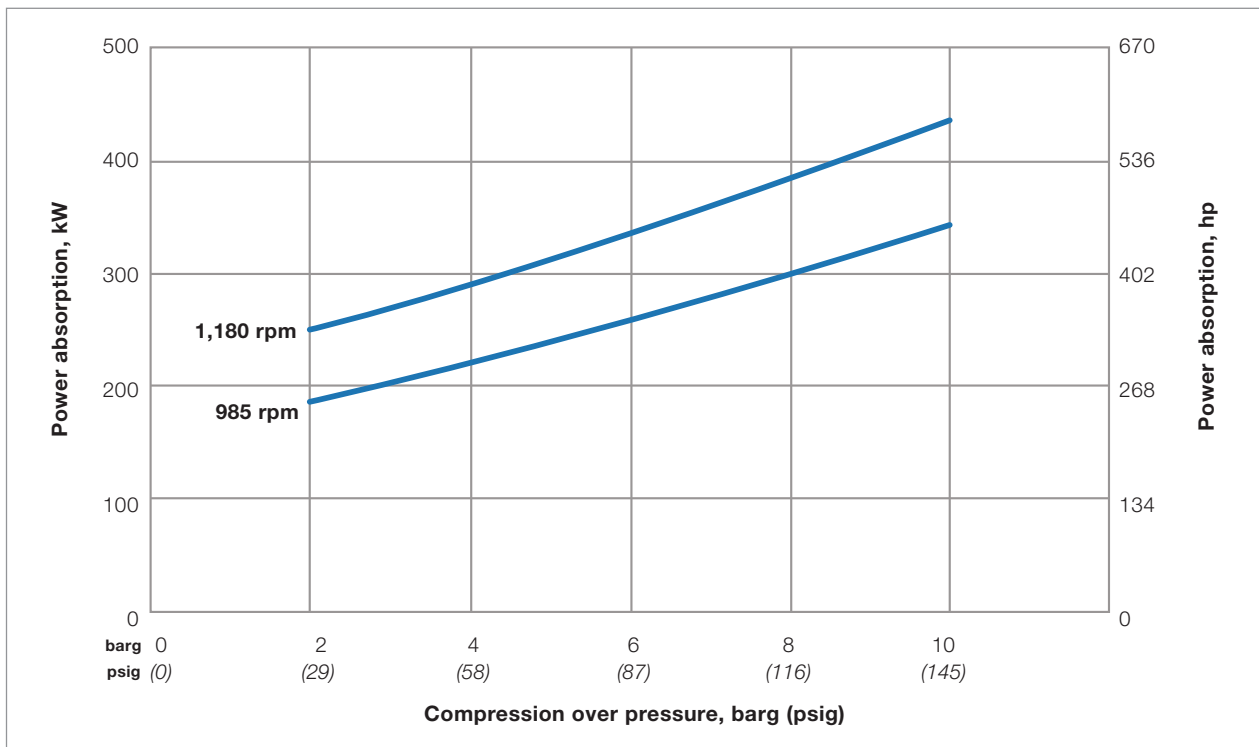
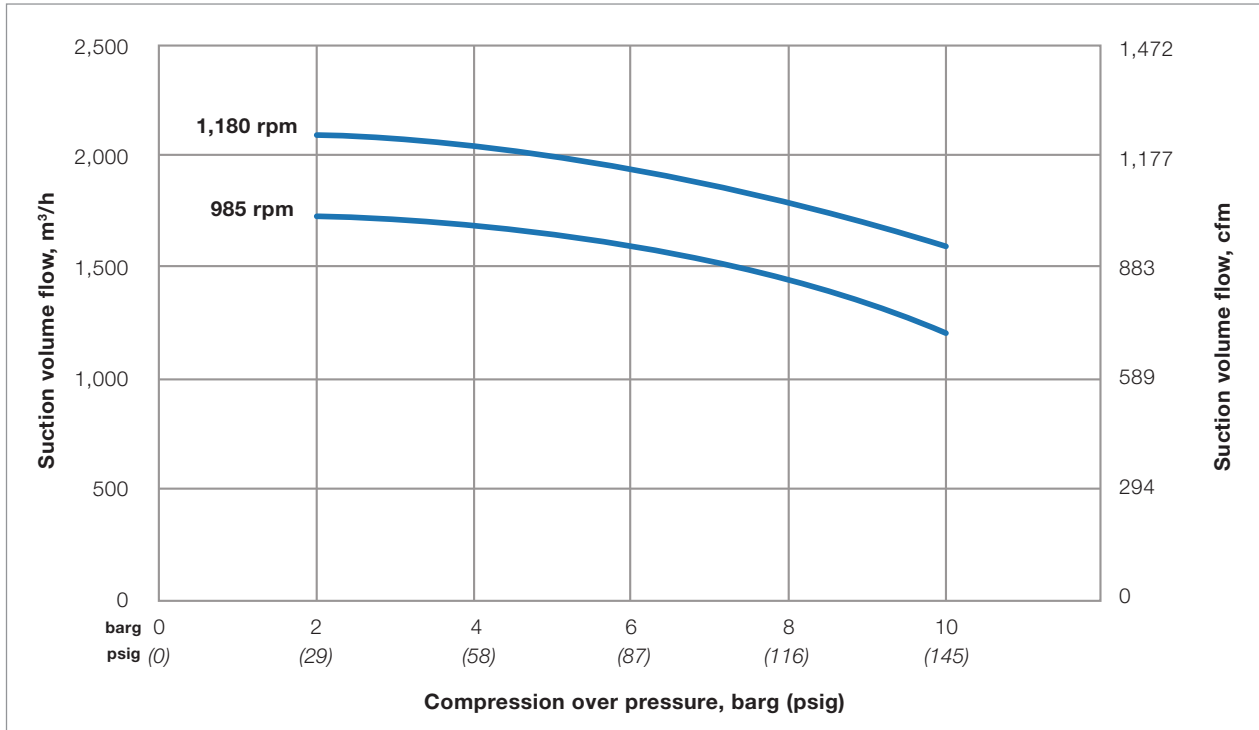

The values indicated for inlet volume flow and power absorption are valid for compression of atmospheric air at 15°C (59°F) and 1,013 mbar (14.69 psi) to the respective compression pressure with water at 15°C (59°F) as a service liquid. Tolerance of the curve values is 10%. The data indicated will change with deviating service conditions, such as deviating physical data of handled gas or of the service liquid used. Data will also change when handling entrained liquid, at suction pressure deviating from atmospheric pressure, or handling gas-vapor mixtures. Other speeds upon request.

Connections and dimensions

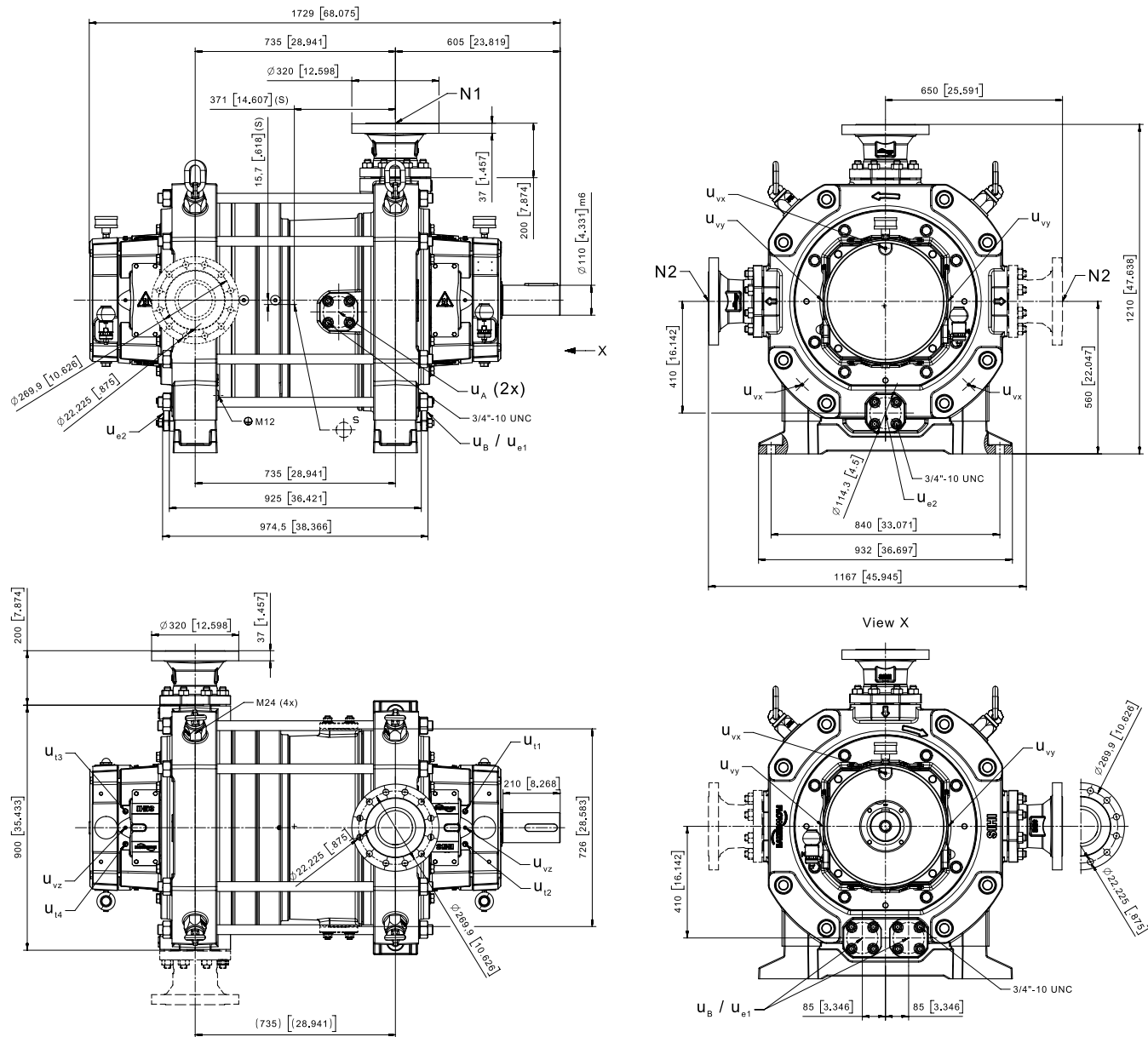

Weight: Approx. 3,140 kg (6,923 lb)

Dimensions in mm [in.]

Connection details

POS	Size	Standard	Designation
N1	6 in.	ASME B16.5 Class 300 RF	Gas inlet
N2	6 in.	ASME B16.5 Class 300 RF	Gas outlet
u _B	1½ in.	ASME B16.5 Class 300 RF	Connection for service liquid
u _{e1} , u _{e2}	1½ in.	ASME B16.5 Class 300 RF	Drain
u _A	1½ in.	ASME B16.5 Class 300 RF	Drain/Extraction
u _{t1} , u _{t2} , u _{t3} , u _{t4}	G¼		Connection for bearing temperature sensor
u _{vx} , u _{vy} , u _{vz}	M8		Connection for vibration sensor

Service liquid

Service liquid requirement dependent on speed

Compressor speed	Service liquid flow rate	Service liquid pressure over suction pressure
985 rpm	12 to 18 m ³ /h (52 to 79 gpm)	1.3 to 2.0 bar (18.9 to 29.0 psi)
1,185 rpm	12 to 18 m ³ /h (52 to 79 gpm)	1.5 to 2.3 bar (21.8 to 33.4 psi)

Reference values, details to be clarified depending on application and system with the supplier.



Flowserve Corporation
5215 North O'Connor Blvd.
Suite 700
Irving, Texas 75039-5421 USA
Telephone: +1-937-890-5839

PUTB000197-02 (EN/A4) November 2022

Flowserve Corporation has established industry leadership in the design and manufacture of its products. When properly selected, this Flowserve product is designed to perform its intended function safely during its useful life. However, the purchaser or user of Flowserve products should be aware that Flowserve products might be used in numerous applications under a wide variety of industrial service conditions. Although Flowserve can provide general guidelines, it cannot provide specific data and warnings for all possible applications. The purchaser/user must therefore assume the ultimate responsibility for the proper sizing and selection, installation, operation, and maintenance of Flowserve products. The purchaser/user should read and understand the Installation Instructions included with the product, and train its employees and contractors in the safe use of Flowserve products in connection with the specific application.

While the information and specifications contained in this literature are believed to be accurate, they are supplied for informative purposes only and should not be considered certified or as a guarantee of satisfactory results by reliance thereon. Nothing contained herein is to be construed as a warranty or guarantee, express or implied, regarding any matter with respect to this product. Because Flowserve is continually improving and upgrading its product design, the specifications, dimensions and information contained herein are subject to change without notice. Should any question arise concerning these provisions, the purchaser/user should contact Flowserve Corporation at any one of its worldwide operations or offices.

©2022 Flowserve Corporation. All rights reserved. This document contains registered and unregistered trademarks of Flowserve Corporation. Other company, product, or service names may be trademarks or service marks of their respective companies.