



USER INSTRUCTIONS

LTQ008 – LTQ230 Series Single-Phase and Low Voltage Products Compact Quarter-Turn Electric Actuator

Installation Operation Maintenance

AIOM000164-00 EN 20

 **Read these instructions prior to installing, operating, and maintaining this equipment.**





Copyright

All rights reserved. No part of these instructions may be reproduced, stored in a retrieval system, or transmitted in any form or by any means without prior permission of Flowserve Corporation.

Document Version

Initial Release, 04-30-2020

TABLE OF CONTENTS

1	General Information	4
1.1	Scope of Manual.....	4
1.2	Disclaimer	4
1.3	Operational Concepts	4
2	Safety Information	6
2.1	Safety Symbols and Descriptions.....	6
2.2	Intended Use.....	6
2.3	General Hazard Sources	7
2.4	Qualified Personnel and Targeted Group.....	8
3	Product Description	9
3.1	General Product Description	9
3.2	Shipping and Handling	10
4	Installation	10
4.1	Installation	10
4.2	Mounting	11
5	Theory of Operation	12
5.1	LTQ008 – LTQ203 NCU (24V – 230V On/Off Control)	12
5.2	LTQ008 – LTQ203 NCU (24V – 230V Proportional Control)	13
5.3	LTQ008 – LTQ203 LL (24V – 230V On/Off Control)	14
5.4	LTQ008 – LTQ203 LL (24V – 230V Proportional Control)	15
5.5	Torque Switches	16
5.6	LTQ LL Series LCS Operation	17
6	Battery Backup	18
6.1	LTQ008-017 Battery	18
6.2	LTQ034-088 Battery	19
6.3	120/230V Transformer Mounting and Setup.....	20
7	Adjustments	21
7.1	Adjusting CW End-of-Travel.....	22
7.2	Adjusting CCW End-of-Travel.....	23
7.3	Adjusting Auxiliary Switches	24
8	Commissioning	25
8.1	Commissioning Procedure for On/Off Control	25
8.2	Commissioning Procedure for Proportional Control	26
8.3	Commissioning LL Control Station On/Off Control.....	26
8.4	Commissioning LL Control Station Proportional Control	27
8.5	Connecting and Starting the Battery System	29
9	Calibration	30
9.1	Calibration Procedure for On/Off Control	30



9.2 Calibration Procedure for Proportional Control (120 – 230 VAC Models)30

9.3 Calibration Procedure for Proportional Control (12 – 24 VAC/VDC Models)33

9.4 Calibration Procedure for LL Control Station Proportional Control35

9.5 Calibration Procedure for On/Off with Battery Backup36

10 Troubleshooting Guide 38

11 Technical Data 41

11.1 Nameplate41

11.2 Torque Requirements42

11.3 Exploded View of LTQ008 – LTQ203 Units43

11.4 Wire Sizing44

Annex A: Glossary 46

1 General Information

1.1 Scope of Manual



These instructions must be kept close to the product's operating location or directly with the product.



Read these instructions prior to installing, operating, using, or maintaining the equipment in any region worldwide. Do not put this equipment into service until meeting each of the safe operating conditions noted in the instructions. **Failure to comply with the information provided in this User Instructions manual is considered to be misuse. The Flowserve warranty does not cover personal injury, product damage, delay in operation, or product failure caused by misuse.**

These instructions aim to familiarize the reader with the product and its permitted use. Operating the product in compliance with these instructions is imperative to ensure reliability in service and to avoid risks. These instructions may not account for all local regulations; ensure the observance of such regulations by all, especially those installing the product. Always coordinate repair activities with operations personnel, and follow all plant safety requirements, applicable safety, and health legislation. For more information on a specific product, refer to the IOM for that product.

1.2 Disclaimer

Information in this User Instruction supplement is believed to be complete and reliable. Despite all of Flowserve's efforts to provide comprehensive information and instructions, sound engineering and safety practices should always be used. Always consult with a qualified engineer.

Flowserve manufactures products to applicable International Quality Management System Standards as certified and audited by external Quality Assurance organizations. Genuine parts and accessories have been designed, tested, and incorporated into the products to help ensure continued product quality and performance in use. As Flowserve cannot test parts and accessories sourced from other vendors, the incorrect incorporation of such parts and accessories may adversely affect the performance and safety features of the product. Flowserve considers the failure to properly select, install, or use authorized Flowserve parts as misuse. The Flowserve warranty does not cover any damage or failure caused by misuse. Moreover, any modification of Flowserve products, or removal of original components, may impair the safety of these products in use.

1.3 Operational Concepts

The LTQ008 Series actuators are fully assembled, calibrated, and tested prior to leaving the factory. In most cases, after mounting the actuator to the desired device, it should be possible to operate the actuator from a fully CW (0°) to CCW (90°), and back again, finding that no adjustments are necessary. If so, the assembly is ready for immediate use. However, should it be necessary to adjust the end-of-travel positions to overcome any device related issues (e.g., the valve shaft incorrectly timed to the drive stem), follow the procedures outlined below in this document to put the assembly into service.

NOTICE

- There is a maximum adjustment range of $\pm 3^\circ$ at each end-of-travel.

Single phase actuators range in complexity from simple models with basic operability, to quite complicated models with a battery backup and local control capabilities. The various models are very specific in how they

interface to existing or new installations, meaning they are not easily adaptable across any site or design intent. Read the project specifications and understand the application before making an actuator selection.

It is important to fully understand what level of control is required prior to selecting one of these products. If in doubt, consult with a project engineer to clarify what is actually required for a fully operational installation. While it might make sense to opt for the most feature-laden solution to cover all the possibilities in a given application, that selection would, in fact, not function in an application that simply required the most basic unit. For this reason, it is imperative to know the application completely before selecting a solution.

Read the project specifications and understand the application before making an actuator selection. If in doubt, consult with a project engineer to clarify what is actually required for a fully operational installation. Despite all of Flowserve's efforts to provide comprehensive information and instructions in this document on how to determine the various actuator levels, questions will arise. **Contact Flowserve for further information before placing orders when unsure of the level of control required.**

NOTICE - Actuators shipped with the battery system disconnected until the unit is commissioned after all installation procedures have been completed.

2 Safety Information

2.1 Safety Symbols and Descriptions

This User Instruction contains specific safety markings where non-observance of an instruction would cause a hazard. The specific safety markings are:

Table 1: Definition of safety symbols and markings

Symbol	Description
	DANGER This symbol indicates a hazardous situation which, if not avoided, will result in death or severe injury.
	WARNING This symbol indicates a hazardous situation which, if not avoided, could result in serious injury.
	CAUTION This symbol indicates a hazardous situation which, if not avoided, could result in minor or moderate injury.
	SAFETY INSTRUCTION This symbol indicates specific safety-related instructions or procedures.
	NOTICE This symbol indicates important, special instructions not related to hazards.
	SAFETY ALERT This is the safety alert symbol. It warns of potential physical injury hazards. Obey all safety messages that follow this symbol to avoid injury or death.
	ELECTRICAL HAZARD This symbol indicates electrical safety instructions where non-compliance would affect personal safety and could result in loss of life.

2.2 Intended Use



The product/system must not be operated beyond the parameters specified for the application. If there is any doubt as to the suitability of the product/system for the application intended, contact Flowserve for advice, quoting the serial number.



- Installing, operating, or maintaining the product/system in any way that is not covered in this User Instruction could cause death, serious personal injury, or damage to the equipment. This includes any modification to the product/system or use of any parts not provided by Flowserve.

- Only operate the product/system when it has successfully passed all inspection acceptance criteria.
- Do not operate the product/system in a partially-assembled condition.
- If the conditions of service on the purchase order change (e.g. pumping fluid, temperature, or duty conditions, etc.), it is imperative that the user seeks written agreement from Flowserve before start-up.
- Observe equipment labels, such as arrows designating the direction of rotation, warning signs, etc., and keep them in a legible condition. Replace any damaged and/or illegible labels immediately.

2.3 General Hazard Sources



DANGER - Read and follow all instructions in this IOM manual and on the equipment. Failure to follow instructions can cause severe injury and/or death.



WARNING - Potential pinch point. Equipment connected to or driven by this device may start unexpectedly, causing personal injury or entrapment in linkage systems.

2.3.1 Mechanical Hazards

a) Lifting limits and guidelines



NOTICE - The load values mentioned in this section are Flowserve recommendations only. Perform all lifting in compliance with site safety protocol, local regulations, and related industry standards.

Many precision parts have sharp corners which require appropriate personal protective equipment during handling. Prior to any attempt to lift an item, employees must first determine the approximate weight and stability of the load.

- Always handle large, unstable, or awkward loads with the assistance of additional personnel or appropriate mechanical means.
- Loads more than 23 kg (50 lb) should only be lifted by appropriate mechanical means and in accordance with current local legislation or with the assistance of additional personnel.
- Lifting items less than 23 kg (50 lb) may be prohibited without assistance if the lift is repetitive and/or awkward (i.e., away from the body, above the shoulders, or below the knees) thus placing excessive stress on the personnel.
- Evaluate repetitive lifting, of any kind, as part of a documented end-user safety program.

b) Manual override

The manual override handwheel allows a user to position the valve or damper with or without power. Turn the handwheel CW to make the output drive move CW (when viewed from above). Turning the handwheel CCW makes the output drive turn CCW.



NOTICE - The LTQ008 Series actuators have mechanical stops which limit rotation. Do not attempt to operate the actuator with a rotation greater than 95°.

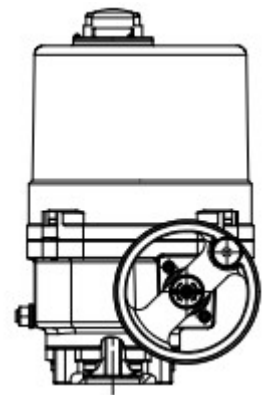

Figure 1: The manual override allows the user to position the valve or damper with or without power.

2.3.2 Electrical Hazards **SAFETY INSTRUCTIONS**

DANGER - Risk of Electric Shock.

- Before working on any electrical equipment, turn off power supply to the equipment.
- All electrical wiring must be in conformance with applicable local codes, regulations, and the National Electric Code (NEC). Hazardous voltage can shock, burn, cause death, or serious property damage. To reduce the risk of electric shock, do not use an extension cord to connect the unit to an electric supply. Provide a properly located electrical receptacle.
- To reduce the risk of electric shock, replace damaged wiring immediately.
- Ground all electrical equipment before connecting to an electrical power supply. Failure to ground all electrical equipment can cause serious or fatal electrical shock hazards.
- Do not ground anything to a gas supply line.
- Failure to bond all electrical equipment to a system structure will increase the risk of electrocution and could result in injury or death. Additionally, contact a licensed electrician for information on local electrical codes for bonding requirements.

2.4 Qualified Personnel and Targeted Group

All personnel involved in the operation, installation, and maintenance of the unit must be qualified to carry out the work involved. If the personnel in question does not already possess the necessary knowledge and skill, appropriate training and instruction must be provided. If required, the operator may commission the manufacturer / supplier to provide applicable training.

Always coordinate repair activities with operation and health and safety personnel. Make sure to follow all plant safety requirements and applicable safety and health laws and regulations.

3 Product Description

3.1 General Product Description

a) LTQ008 – LTQ203

The LTQ008 – LTQ017 Series are quarter-turn, electric industrial service actuators delivering up to 1770 lbf-in of torque with voltages ranging from 12V to 230V with on/off or proportional control modes. These NEMA 4X and IP67 compliant units are equipped with two volt-free Form A auxiliary switches rated at, up to, 10A 250VAC and a standard clutch-free, manual-override handwheel. Additionally, these units feature two ¾" EMT entry ports with sealed cable glands and a raised visual position indicator, as standard. Users have the option to customize these units with the following features: torque switches, motor control centers, local control stations, IP68 submersible, battery backup, supercap backup, and interchangeable ISO5211 flanges and drives. This series is ISO5211 compliant, mounting with double, square female drive inserts.

b) Control Station

Local Control Stations (LCS) provide a means to select Local or Remote control of a valve or damper actuator. The LCS offered on the 008-203 sizes (LL) features unique capabilities, LED feedback, and a human-machine interface.

c) Battery Backup

The LTQ008-088 Series actuators ending in "B0B00" have an internal battery backup system and are quarter-turn industrial electric actuators designed to operate valves and dampers in municipal, heavy commercial or industrial applications. These units are NEMA 4/4X, IP67 rated, and feature on/off or proportional control versions to interface to most field control signals. The LTQ008-088 Series with battery backup operate on 24vac or 24vdc power supplies. Limitorque offers 120v and 230v transformers packaged in stainless steel wall mounted enclosures sized to provide the required power for the actuator and the battery system.

The battery pack and charge controller are integral to the actuator housing in the 034-088 and in an attached compartment in the 008-017. Wiring of the actuator and battery system is completed through access to a single terminal location. The battery system is designed to provide a minimum of two years of field service (depending on application and actual conditions of use). The battery pack is field replaceable.

3.1.1 Type LL (LED type)

This is a NEMA 4/4X and IP67 (optional IP68) type, rectangular enclosure, that is integral to the actuator housing. This type contains two non-intrusive (magnetic) knob switches for mode and position control. This version also employs an LED panel with five, bright LEDs mounted behind the glass with indicators for actuator operations. The two rotary control knobs provide the user with the ability to operate the actuator in a normal (REMOTE) mode where the actuator responds to control signals from a BAS, PLC, or other control device. Or the user can elect to operate the actuator in a LOCAL mode where the user can control the positioning of the actuator while standing at the device. This allows opening and closing of the actuator (valve) to test for operation and to perform maintenance, or other function, without relying on radio communication to command the automation system to position the actuator. The five LEDs provide a visual indication of the position and status of the actuator with indicators for open, close, remote, local, and fault. Open (green) and close (red) flash when the actuator is moving CCW (90°) or CW (0°), respectively, and they remain lit upon reaching the end-of-travel. This version is available on the LTQ008 through the LTQ203 Series for all single-phase and low voltage actuators.

3.2 Shipping and Handling

This actuator arrives in the fully CW (0°) position. The red/green position indicator should show all red to denote this. The actuator has a red and green position indicator on the top of the unit. The red color in the indicator window means the actuator is fully CW (0°), while the green color means the actuator is fully CCW (90°). The indicator has graduations for percent of full travel.

Storage

This unit should not be stored outside unless it is powered up and has proper conduit terminations. When not powered up, it should be stored in a clean, dry environment at all times.

This quarter-turn actuator has been factory tested and calibrated to operate between 0° and 90°. Most products will not require recalibration of these settings. If any travel adjustment is necessary, refer to



Figure 2: Red/green position indicator on top of actuator

4 Installation

CAUTION - Follow the guidelines below for proper installation.

- These actuators are designed to be used between a horizontal and upright position. Do not mount the assembly with the actuator top below a horizontal position (i.e. upside down).
- Protect the actuator from moisture by installing it with water-tight, electrical metallic tubing (EMT) fittings and proper conduit drainage. Supply power to the unit to keep the internal heater warm at the time of installation (BIC units only).
- When installing conduit, use proper techniques for entry into the actuator. Use drip loops to prevent conduit condensate from entering the actuator.
- Mechanical travel stops are factory calibrated for 90° of operation. These stops are not designed to adjust mechanical rotation by more than ± 3°; they are only for positioning the handwheel.
- Use proper equipment on both EMT conduit ports to protect the NEMA 4X integrity of the housing.
- Use the internal heater in all applications.
- Do not install the actuator outdoors, or in humid environments, unless it is powered up and the heater is functioning.
- Use the proper wire size to prevent actuator failure (see 11.4 for proper wire sizing).
- Terminals 1 – 3 accept 12 – 18 AWG solid / stranded wire. Terminals 4 – N accept 14 – 18 AWG solid / stranded wire.

4.1 Installation

NOTICE - This User Instructions manual references the LTQ008-203 Series actuator rotation direction while viewed from above the actuator.

CAUTION - Do **NOT** install battery backup units in direct sunlight.

All LTQ008-203 Series actuators rotate CW to drive the output shaft (bottom of the actuator) to the 0° position. On all LTQ008-203 Series actuators, the cam shaft, and the indicator, rotate CW to 0° as well.

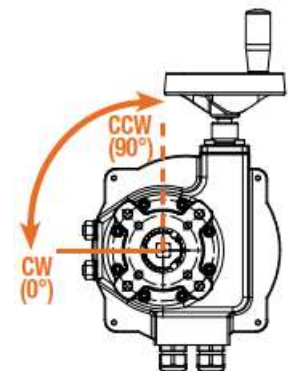

Figure 3: Note that the rotation seen from below is a mirror of the direction viewed from above.

4.2 Mounting

1. Fully close the valve or damper to which the actuator is to be mounted.
2. Assemble the necessary linkage hardware and attach the actuator to the valve or damper.
3. Center the actuator on the valve or damper drive shaft and tighten all the hardware.
4. **Before applying power to the unit**, rotate the manual override handwheel from the fully CW (0°) to the fully CCW (90°) position to check for unobstructed manual operation of the valve or damper.
5. The LTQ008 Series 3-phase actuators utilize a PCB to simply field wiring and testing. This PCB contains one of the terminal blocks.
 - a. The green terminal block is for incoming power, and it contains screw terminals 1 – 3. It is rated for up to 575V.

NOTICE

- Terminal numbering starts with 1 at the bottom.
 - b. The blue terminal block contains screw terminals 4 – 9 and A – N which are rated to accept 14 AWG down to 18 AWG solid or stranded wire. These are used for interfacing and control wiring.
6. Reference the actuator's product number to determine which diagram to follow when wiring the actuator.
 7. Note that although terminals are labeled as 1 – 9 and A – N, not all terminals are used on all models.

CAUTION

- Be sure to make field connections to the proper terminal as identified by the **label** and not the position.

8. Make the electrical connections per the appropriate wiring diagram for the actuator.
9. Connect power and control to the correct terminals.
10. Terminals E – N on each actuator are for the auxiliary (adjustable) switches, which are dry type (voltage free) Form A contacts rated for 24V @ 1A Max.

WARNING

- **The torque switches are factory set and are not adjustable.**

Torque switches protect controlled valves or actuators from damage in the event of a high torque condition.

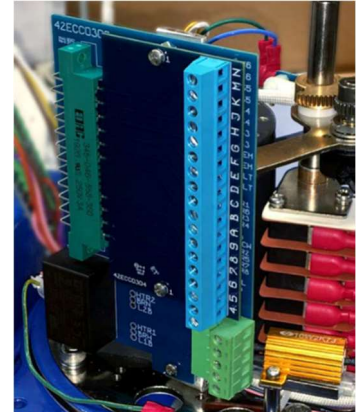

Figure 4: Printed circuit boards (PCB) contain the terminal block. They facilitate simple field wiring and testing.



Figure 5: A torque switch (TS) is a secondary set of cams (switches) which further protects the actuator, equipment, and processes.

5 Theory of Operation

Background: Flowserve offers several types of single-phase actuators that are designed to fit applications ranging from basic controls to fully-optioned solutions. These various strategies form the levels described below which allow a product to fit functionally and economically into most single-phase applications.

5.1 LTQ008 – LTQ203 NCU (24V – 230V On/Off Control)

Inside the actuator/LCS package:

1. Starting with the most basic design are the NCU Series actuators. These models are designed for use with existing single-phase installations where motor control centers are already established.
 - a. The remote devices must have volt-free contacts (dry contacts) which will switch the actuator's internal power supply to generate commands to drive CW (0°) or CCW (90°).
 - b. **No Local Control Device.** There is no way to operate the actuator locally. Only the existing Motor Control Center (MCC) and the controls already on-site can operate the actuator. Without some type of MCC, there will be no way to drive the actuator in either direction

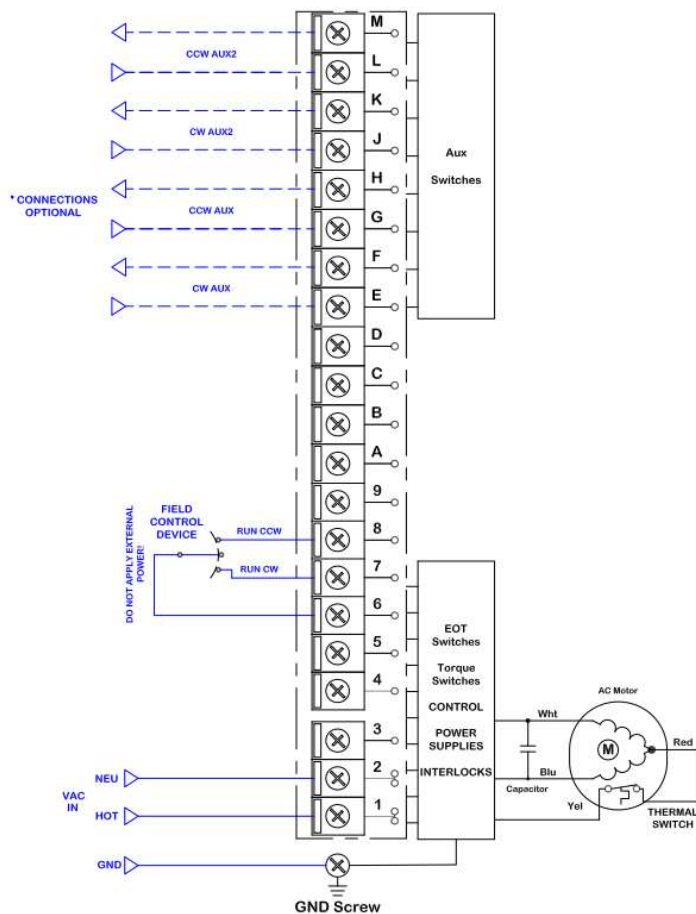

Figure 6: LTQ008 – LTQ203 NCU (24V – 230V On/Off control) 120 V wiring diagram; others available

5.2 LTQ008 – LTQ203 NCU (24V – 230V Proportional Control)

Inside the actuator/LCS package:

1. These models are designed to be used where there are no existing MCCs. Typically, these are used in new facilities, or where additions to existing switch gears have available space limitations or is otherwise just not feasible. The actuator generates a 24V status output that can be used remotely to verify power. These units accept analog control signals (4 – 20 mA or 2 – 10 VDC), and they process the incoming signals to position the actuator as a function of the incoming signal. Additionally, these units generate an analog feedback signal proportional to the position of the actuator, which is not directly related to the incoming signal. This feedback signal is designed to be used by automation devices or displays external to the actuator.

- a. **No Local Control Device.** There is no way to operate the actuator locally. It can only be operated by utilizing an external PLC, BAS, or other automation controller generating 4 – 20 mA or 2 – 10 VDC analog signals to position the actuator between 0° and 90°. Without some type of automation interface, there will be no way to command the actuator to move in either direction.
- b. **Proportional Controller.** This analog processing PCB accepts 4 – 20 mA or 2 – 10VDC from the field accordingly.

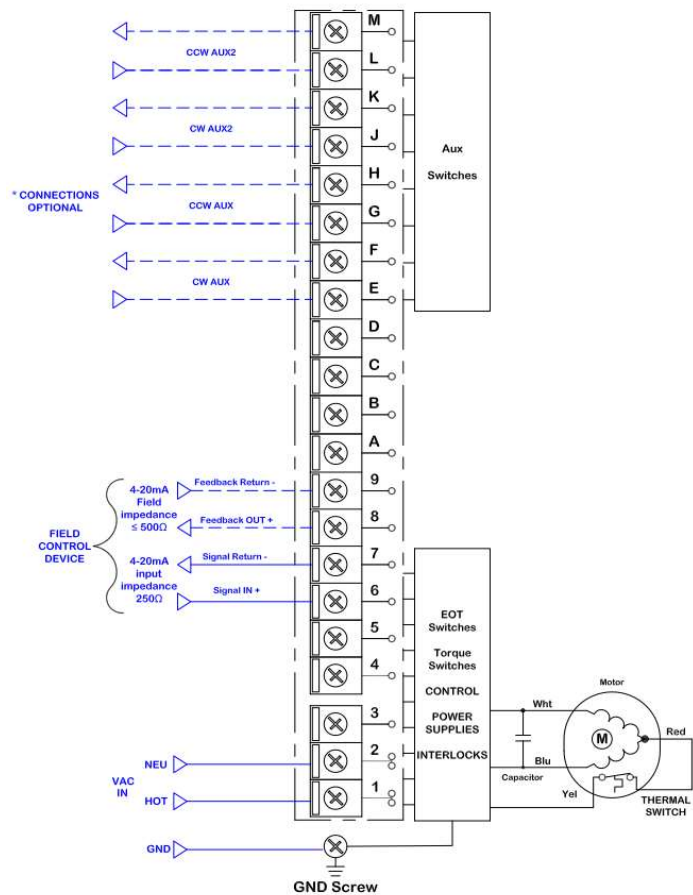

Figure 7: LTQ008 – LTQ203 NCU (24V – 230V Proportional control) 120 V wiring diagram; others available

5.3 LTQ008 – LTQ203 LL (24V – 230V On/Off Control)

Inside the actuator/LCS package:

2. **Integral Local Control Device.** The design of this series allows for LOCAL mode (control knobs or buttons located on the face of the LCS, which is an integral part of the actuator) or REMOTE mode, which utilizes commands from a PLC, BAS, or other volt-free contact (dry contact) automation device.

- a. While in REMOTE mode, the remote devices must have volt-free contacts (dry contacts) which will switch the actuator's internal power supply to generate commands to drive CW (0°) or CCW (90°).
- b. While in LOCAL mode, the actuator responds to the position of the controls located on the face of the integral LCS.

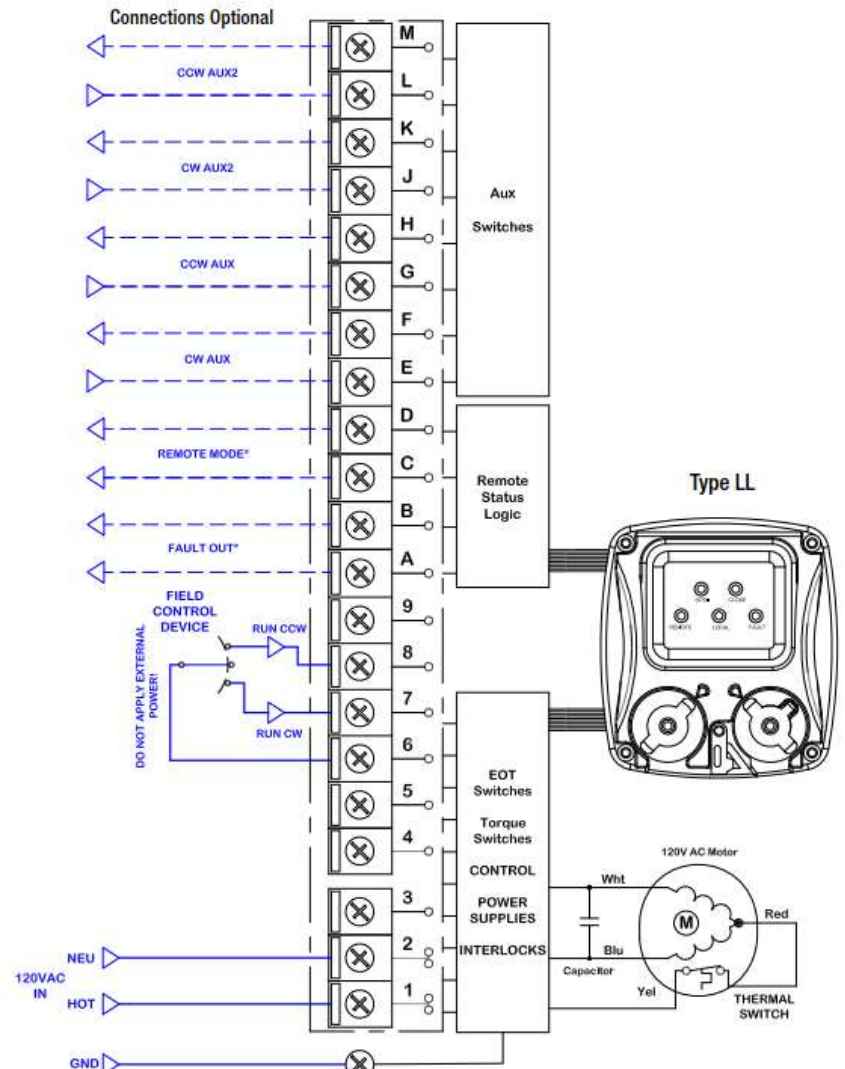

Figure 8: LTQ008 – LTQ203 LL (24V – 230V On/Off control) 120 V wiring diagram; others available

5.4 LTQ008 – LTQ203 LL (24V – 230V Proportional Control)

These units accept analog control signals (4 – 20 mA or 2 – 10 VDC) and process these incoming signals to position the actuator as a function of the incoming signal. Additionally, these units generate an analog feedback signal proportional to the position of the actuator, which is not directly related to the incoming signal. This feedback signal is designed to be used by automating devices or displays external to the actuator.

Inside the actuator/LCS package:

1. **Integral Local Control Device.** The design of this series allows for LOCAL mode (control knobs or buttons located on the face of the LCS, which is an integral part of the actuator) or in REMOTE mode, which utilizes commands from a PLC, BAS, or other volt-free contact (dry contact) automation device.

a. While in LOCAL mode, the actuator responds to the position of the controls located on the face of the integral LCS.

b. The mode switch employs a padlockable lever that locks the mode switch in any of its three positions, preventing unauthorized changes in the operating mode (LOCAL, OFF, or REMOTE).

2. **Proportional Controller.** When the unit is in REMOTE mode, the analog processing PCB accepts 4 – 20 mA or 2 – 10 VDC from the field and positions the actuator accordingly, utilizing the internal reversing motor starter. A 4 – 20 mA or 2 – 10 VDC feedback signal is internally generated to provide a remote reading of the position of the actuator.

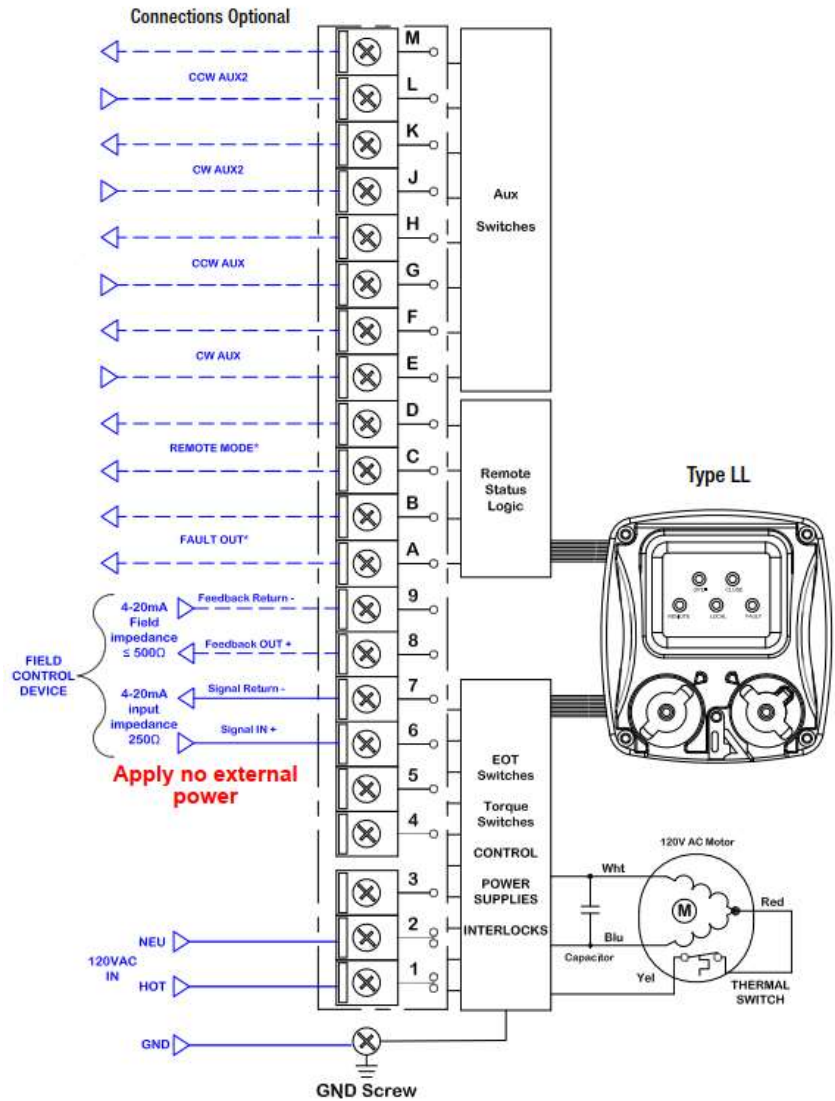

Figure 9: LTQ008 – LTQ203 LL (24V – 230V Proportional control) 120 V wiring diagram; others similar

5.5 Torque Switches

▲WARNING - Torque switches are factory set and are not adjustable. Changing these settings will void the actuator warranty.

Torque Switch Operation

The LTQ008 Series actuators have torque switches to protect the actuator, and any attached equipment, from possible damage that could occur in a high torque event. In such an event, the valve or damper being driven encounters some blockage or impediment to travel. In the case of an actuator without torque switches, the actuator will attempt to drive until it either reaches the end-of-travel or (likely) the motor overworks and trips on a thermal overload. Units with torque switches will cease supplying power to the motor when a high torque event occurs.



Figure 10: The torque switch cams and switches are shown in the normal operating position.

The upper torque switch and cam for the actuator drive the CW rotation.

The lower torque switch and cam for the actuator drive CCW rotation.

Torque switch – Normal mode

1. In normal operating mode, the torque switch and drive cam are in the neutral position shown in the photo.
2. Internal gearing in-line with the output drive provide the rotational action for the cams.
3. The upper torque switch protects CW rotation.
4. The lower torque switch protects CCW rotation.



Figure 11: The upper cam is tripping the upper switch.

The upper cam has rotated CCW from its neutral position, engaging the switch.

Torque Event – CW

1. **Error! Reference source not found.** shows a high torque event in the CW direction.
2. The torque switch CW drive cam (upper) and the switch are in the tripped position.
3. When the torque switch trips, it immediately cuts off power flow to the motor for that direction of travel.



Figure 12: The lower cam is tripping the lower switch.

The lower cam has rotated CW from its neutral position, engaging the switch.

Torque Event – CCW

1. **Error! Reference source not found.** shows a high torque event in the CCW direction.
2. The torque switch CCW drive cam (lower) and the switch are in the tripped position.
3. When the torque switch trips, it immediately cuts off power flow to the motor for that direction of travel.

5.6 LTQ LL Series LCS Operation



Figure 13: Panel shown in the STOP mode

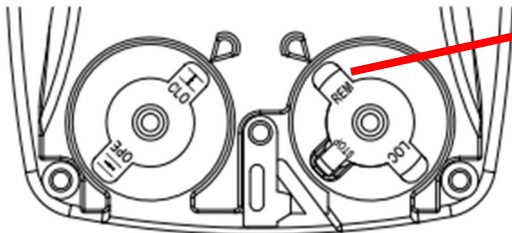

Figure 14: Panel shown in the REM mode

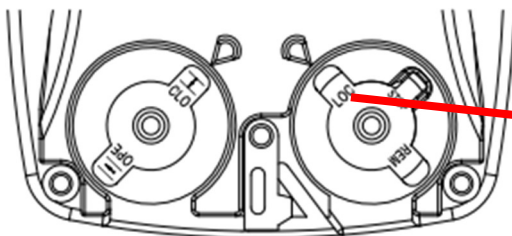

Figure 15: Panel shown in the LOC mode, driving CW

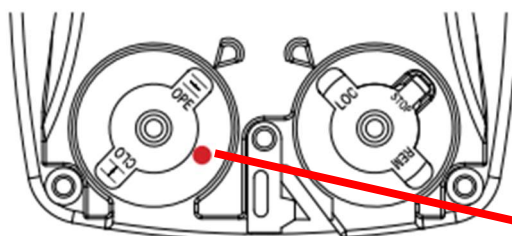

Figure 16: Panel shown in the LOC mode, driving CCW

NOTICE - There is a padlockable lever that engages with the mode knob to lock the operation of the mode switch in position. It provides restricted access in any of the three positions.

Operating the Local Control Station

1. The mode switch (right hand side) has three positions:

i. STOP (center position)

On/Off actuators: This position removes any ability to reposition the actuator electrically. Power is still present in the unit, and the open and close LED indicators are operational. When fully CW (0°), the red LED will be steady on. Due to its epicyclic gear train, the manual handwheel can be used to position the actuator. The actuator will remain in the position last determined by the use of the handwheel.

Proportional control actuators: In this position, the actuator generates a 4 – 20 mA (2 – 10 VDC) feedback signal out, respective of the position of the actuator.

ii. REM (REMOTE)

On/Off actuators: This position sets the actuator to respond to field generated control signals. In this mode, the position knob (left side) does not affect the positioning of the actuator. The external signal device controls all actuator movement. The manual handwheel may be used to reposition the actuator while in this mode; however, if an active, external signal is present, the actuator will reposition as a result of that control signal. The LED indicators are active in this mode.

Proportional control actuators: The actuator follows the incoming 4 – 20 mA (2 – 10 VDC) control signal, generating a 4 – 20 mA (2 – 10 VDC) feedback signal out, respective of the position of the actuator.

iii. LOC (LOCAL)

On/Off actuators: This position sets the actuator to respond to the position knob. In this position, the LED indicators are active, and all external field signals are ignored, having no effect on the positioning of the actuator.

Proportional control actuators: The actuator responds to the function of the position knob, generating a 4 – 20 mA (2 – 10 VDC) feedback signal out, respective of the position of the actuator.

2. The position switch (left hand size) has three positions that the actuator responds to when in the LOC mode:

i. **OPE** (CCW, all models): The actuator will drive to the fully CCW position.

ii. **CLO** (CW, all models): The actuator will drive to the fully CW position

NOTICE

- There is an unmarked hold position detente in the knob (red dot in in **Error! Reference source not found.**) that allows the actuator to maintain position at some point away from the full travel end-stops. In this mode, the manual handwheel may be used to reposition the actuator, and it will remain in this position while the position knob is in the hold position. The LED indicators are active in this mode, and all external field signals are ignored, having no effect on the positioning of the actuator.

6 Battery Backup

6.1 LTQ008-017 Battery

The LTQ008 Series Battery Backup units are fitted with a battery storage enclosure mounted directly onto the actuator as shown.



Battery and Controls Enclosure
(No field terminations)

All wiring for the battery pack is complete and an internal disconnect for the battery system is provided.

No need to remove the cover unless replacing the battery pack.

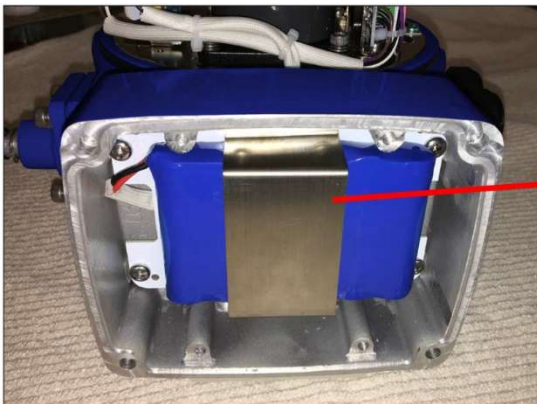

Battery Pack

WARNING

- Do **NOT** install battery backup units in direct sunlight.

NOTICE

- The battery system should remain **UNPLUGGED** until **AFTER** the actuator has been mounted and tested for proper travel and end stop calibration.

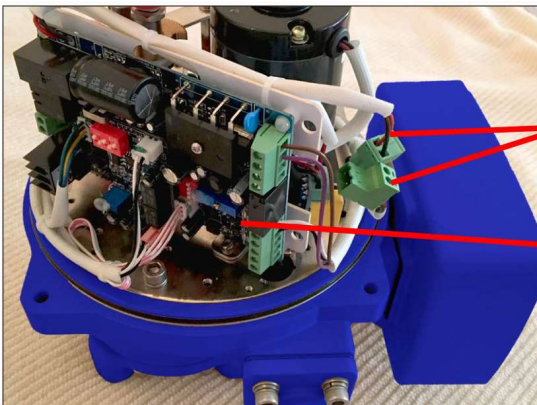

Battery Disconnect
(Male/Female Pair)

Control Board
All field terminations are made here

6.2 LTQ034-088 Battery

The LTQ034-088 Series Battery Backup units are fitted with a battery storage enclosure mounted to a bracket inside the actuator as shown. All wiring for the battery pack is complete and an internal disconnect for the battery system is provided.

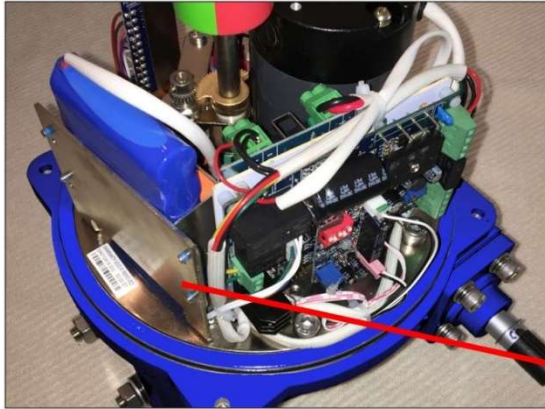

Bracket

⚠ WARNING - Do **NOT** install battery backup units in direct sunlight.



Battery Pack

NOTICE - The battery system should remain **UNPLUGGED** until **AFTER** the actuator has been mounted and tested for proper travel and end stop calibration.

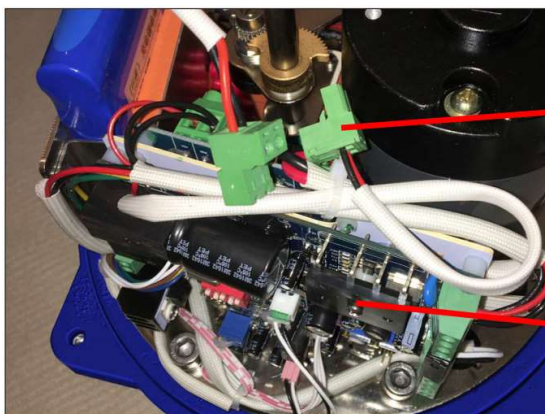

Battery Disconnect

Control Board
All field terminations are made here

6.3 120/230V Transformer Mounting and Setup

Power Supply:

The LTQ034 Series Battery Backup units require a 500VA 24vac / 20A 24vdc power supply directly into the actuator terminal block. To facilitate various site power availability, an optional enclosure is offered which houses an appropriately sized toroidal transformer to supply the 24V power to the actuator. Mounted separately, the enclosure is a NEMA 4X / IP65 9 x 7 x 6 hinged door cabinet. Mounted to a back plane, the transformer primary and secondary are pre-wired to a six position dual terminal block.

Notes:

The enclosure, while NEMA 4X rated, should NOT be installed in direct sunlight. If installed outdoors, it should be installed in the shade under a rain hood using rain-tight conduit fittings and connectors.

The Enclosure is a sealed NEMA 4X type stainless steel type without conduit holes or knock-outs. This allows complete flexibility when mounting. The enclosure can be oriented in any direction, and can be mounted on wall, floor, ceiling, uni-strut or any other fixed surface. Conduit penetrations by others. Interconnect wiring between transformer panel and actuator by others per the supplied wiring diagram.



Figure 17: LTQ Series Transformer Enclosure (120/230VAC Installations)



Figure 18: LTQ Series Transformer (120/230VAC Installations)

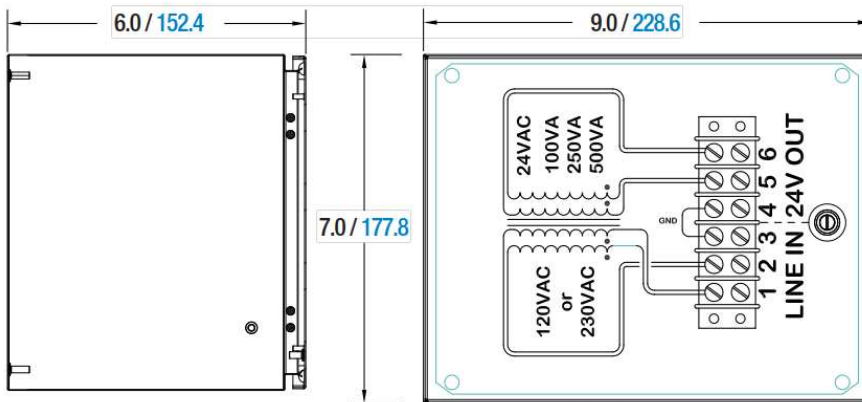

Figure 19: LTQ Series Transformer Enclosure Dimensional Data

Model	Line	Power	Size in / mm	Weight lbs / kg
LTQBBC120-100	120VAC	100VA	9.0 W x 7.0 H x 6.0 D	12 / 5.5
LTQBBC120-250	120VAC	250VA		14 / 6.4
LTQBBC120-500	120VAC	500VA		20 / 9.1
LTQBBC230-100	230VAC	100VA	228.6 W x 177.8 H x 52.4 D	12 / 5.4
LTQBBC230-250	230VAC	250VA		14 / 6.4
LTQBBC230-500	230VAC	500VA		20 / 9.1

7 Adjustments

This actuator arrives calibrated and tested by the factory to stop at 0° for the CW position and 90° for the CCW position. The auxiliary switch settings are based on the CW and CCW stops. Ideally, the auxiliary switches are set a few degrees in advance of the respective stop switches. Most installations onto valves or dampers will likely not require recalibration of these settings. Mount the valve or damper. **If the unit requires adjustments**, proceed to sections 7.1, Adjusting CW End-of-Travel, and 7.2, Adjusting CCW End-of-Travel. Otherwise, proceed without adjusting the cams

NOTICE

- For most actuators, the stop positions are independent of one another – e.g., the CW position is accurate while the CCW position may need adjustment.
- Follow these directions carefully and in order. Actuator damage due to improper testing and commissioning will not be covered under the warranty.

DANGER

- To avoid the dangerous or fatal electrical shock, **turn off power** to all electrical equipment before working on electrical connections or changing cam positions.
- The mechanical stop screw **only limits** handwheel operation; it is not to be used as an electrical travel limiting device.

7.1 Adjusting CW End-of-Travel

1. Reposition Mechanical Stop
 - a. **Disconnect power.**
 - b. Loosen the right-side mechanical stop. This is the CW mechanical stop limit adjustment. Using a 17 mm wrench and a 5 mm hex key, hold the jam nut and turn the stop screw 5 – 6 turns CCW so it clears the mechanical box inside the actuator.
 - i. This will allow the user to adjust the cam/switch stop position without running into the mechanical stop screw.
 - c. Use the manual override handwheel to position the actuator to the required CW position. Keep all changes within $\pm 3^\circ$ of the factory settings.
2. Adjust CW Cam (Bottom)
 - a. Cam 1 is the bottom cam (red) and the end-of-travel adjustment for the actuator CW position. With power off, and the actuator at its required CW position, use a sharp 2.5 mm hex key to free up the cam set screw. **Take care not to let the hex key slip at this stage; it can easily strip out.** Once the screw is free, adjust it as detailed below:
 - i. Rotate the hex key to the right 10 – 15° until an audible click is heard. This will reset the switch roller arm.
 - ii. Gently tighten (CW) the set screw (only until slight pressure is felt). Ideally, the set screw rides along the camshaft.
 - iii. **Slowly** rotate the hex key to the left, pushing the cam, until an audible click is heard on the bottom switch. The click means correct adjustment has been achieved.
 - iv. Tighten the cam set screw.
 - b. Apply power and test for the correct CW position:
 - i. Drive the actuator CCW at least 15 – 20°.
 - ii. Drive the actuator CW until the cam stops the electrical travel.
 - iii. Verify that the CW position matches the one required.
 - iv. Repeat step 2a if further adjustment is needed.
3. Tighten Mechanical Stop
 - a. With the actuator in the proper position, hold the 17 mm wrench on the right-side jam nut to prevent the jam nut from locking. Turn the 5 mm hex key CW until the end of the stop screw bottoms out against the internal stop boss.
 - b. Turn the hex key **one full turn CCW**, and lock the position with the jam nut. Now, the actuator will reach its end-of-travel electrically before there is any interference from the mechanical stop.
 - c. The CW position calibration is now complete.



Figure 20: CW mechanical stop

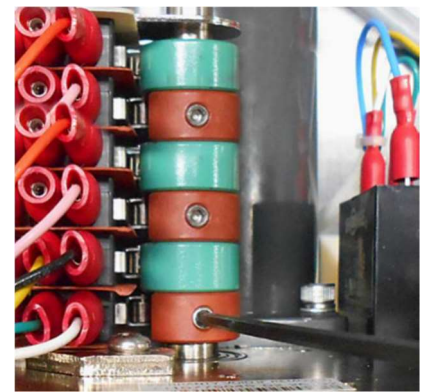

Figure 21: Cam 1 (bottom, CW cam)

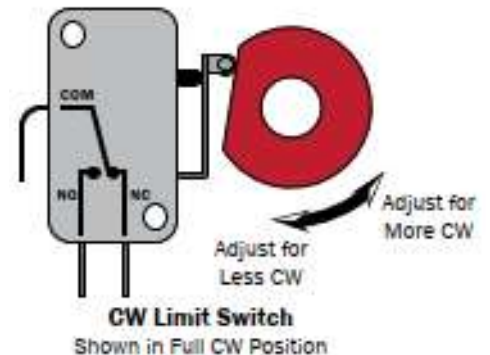

Figure 22: The CW limit switch shown in the fully CW position

7.2 Adjusting CCW End-of-Travel

1. Reposition Mechanical Stop

- a. **Disconnect power.**
- b. Loosen the left-side mechanical stop. This is the CCW mechanical stop limit adjustment. Using a 17 mm wrench and a 5 mm hex key, hold the jam nut and turn the stops screws 5 – 6 turns CCW so it clears the mechanical boss inside the actuator.
 - i. This will allow the user to adjust the cam/switch stop position without running into the mechanical stop screw.
- c. Use the manual override handwheel to position the actuator to the required CCW position. Keep all changes within $\pm 3^\circ$ of the factory settings.



Figure 23: CCW mechanical stop

2. Adjust CCW Cam (Second from Bottom)

- a. Cam 2 is the second cam up from the bottom (green) and the end-of-travel adjustment for the actuator CCW position. With power off, and the actuator at its required CCW position, use a sharp 2.5 mm hex key to free up the cam set screw. **Take care not to let the hex key slip at this stage; it can easily strip out.** Once the screw is free, adjust it as detailed below.
 - i. Rotate the hex key to the left 10 – 15° until an audible click is heard. This will reset the switch roller arm.
 - ii. Gently tighten (CW) the set screw (only until slight pressure is felt). Ideally, the set screw rides along the camshaft.
 - iii. **Slowly** rotate the hex key to the right, pushing the cam, until an audible click is heard on the bottom switch. The click means correct adjustment has been achieved.
 - iv. Tighten the cam set screw.
- b. Apply power and test for the correct CCW position.
 - i. Drive the actuator CW at least 15 – 20°.
 - ii. Drive the actuator CCW until the cam stops the electrical travel.
 - iii. Verify that the CCW position matches the one required.
 - iv. Repeat step 2a if further adjustment is needed.

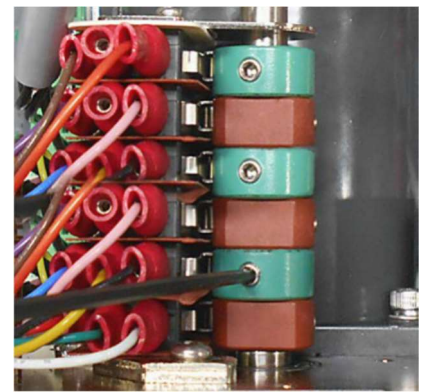

Figure 24: Cam 2 (second from bottom, CCW cam)

3. Tighten Mechanical Stop

- a. With the actuator in the proper position, hold the 17 mm wrench on the left-side jam nut to prevent the jam nut from locking. Turn the 5 mm hex key CW until the end of the stop screw bottoms out against the internal stop boss.
- b. Turn the hex key **one full turn CCW**, and lock the position with the jam nut. Now, the actuator will reach its end-of-travel electrically before there is any interference from the mechanical stop.
- c. The CCW position calibration is now complete.

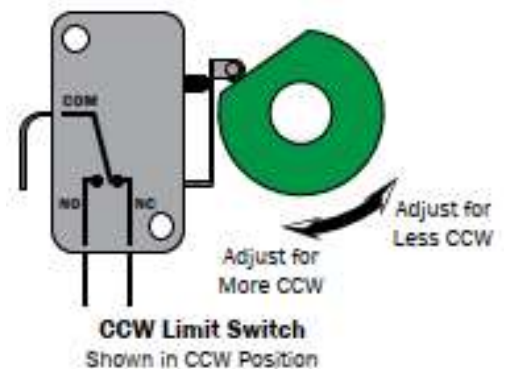

Figure 25: The CCW limit switch shown in the fully CCW position

7.3 Adjusting Auxiliary Switches

1. Adjust CW auxiliary cams
 - a. Cam 3 (red) and cam 5 (red) control the CW auxiliary switch adjustments. These are optional switches typically used to indicate when the actuator has reached its CW position.
 - b. Drive the actuator to its CW position. Use a sharp 2.5 mm hex key to free up the cam set screw. **Take care not to let the hex key slip at this stage; it can easily strip out.** Once the screw is free, adjust it as detailed below:
 - i. On cam 3, rotate the hex key to the right 10 – 15° until an audible click is heard. This will reset the switch roller arm.
 - ii. Gently tighten (CW) the set screw (only until slight pressure is felt). Ideally, the set screw rides along the camshaft.
 - iii. **Slowly** rotate the hex key to the left, pushing the cam, until an audible click is heard on the bottom switch.
 - iv. Continue to rotate the cam between 3 and 5° to the left to ensure that the auxiliary cam switch changes state before the actuator reaches its end-of-travel electrically.
 - v. Tighten the cam set screw.
 - vi. Repeat this procedure for cam 5.
2. Adjust CCW auxiliary cams
 - a. Cam 4 (green) and cam 6 (green) control the CCW auxiliary switch adjustments. These are optional switches typically used to indicate when the actuator has reached its CCW position.
 - b. Drive the actuator to its CCW position. Use a sharp 2.5 mm hex key to free up the cam set screw. **Take care not to let the hex key slip at this stage; it can easily strip out.** Once the screw is free, adjust it as described below:
 - i. On cam 4, rotate the hex key to the left 10 – 15° until an audible click is heard. This will reset the switch roller arm.
 - ii. Gently tighten (CW) the set screw (only until slight pressure is felt). Ideally, the set screw rides along the camshaft.
 - iii. **Slowly** rotate the hex key to the right, pushing the cam, until an audible click is heard on the bottom switch.
 - iv. Continue to rotate the cam between 3 and 5° to the right to ensure that the auxiliary cam switch changes state before the actuator reaches its end-of-travel electrically.
 - v. Tighten the cam set screw.
 - vi. Repeat this procedure for cam 6.



Figure 26: Cam 3 and cam 5 (CW auxiliary switch cams, red)



Figure 27: Cam 4 and cam 6 (CCW auxiliary switch cams, green)

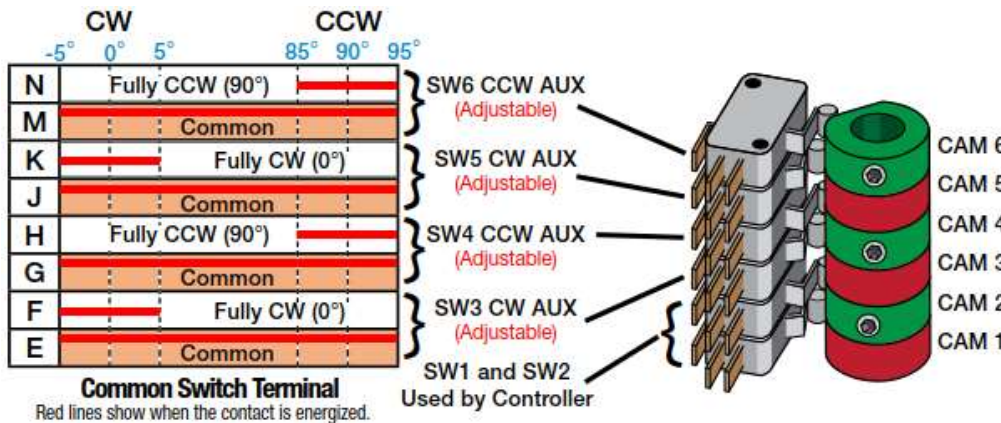

Figure 30: Auxiliary switch cam mapping



Figure 28: CW limit switch shown in the fully CCW position

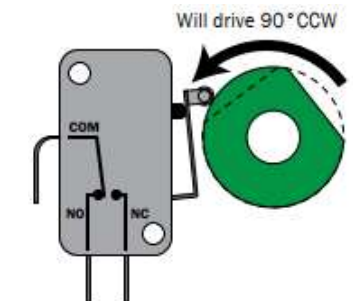

Figure 29: CCW limit switch shown in the fully CW position

8 Commissioning

NOTICE - The factory sets and tests the end-of-travel stops (cams) of this actuator to respond between 0° and 90° of rotation. If the end stops require no changes, this unit is ready for immediate operation using the following procedure. However, if the cam positions require changes, refer to section 7,

SAFETY INSTRUCTIONS - This procedure first establishes correct direction and control as these must be verified to proceed. Regardless of the level of the three-phase actuator, the actuator must drive CW when commanded to do so and stop when the actuator reaches the fully CW travel position. The same applies to the CCW operation.

WARNING - Follow these directions carefully and in order. Actuator damage due to improper testing and commissioning will not be covered under the warranty.

DANGER - This procedure has many sections with the text “**immediately remove power from the actuator to stop movement**”. Quick action is necessary to prevent the actuator from possibly driving into the mechanical stops, past the limits of the valve or damper attached, and to simply keep the actuator in a known position for a quick, efficient installation as a result of any unexpected or uncontrolled movement.

8.1 Commissioning Procedure for On/Off Control

WARNING - **Allowing the motor to drive the gear train into the mechanical stop will result in severe damage to the actuator!** Remove power from this device before making any travel adjustments.

After completing all mounting and wiring procedures, and main power is available, it is now possible to commission the actuator.

1. Utilize the handwheel or override shaft to rotate the actuator and damper, valve, or other connected device through its full travel from fully CW to fully CCW, and back again, to check for any possible interference. Do not utilize any mechanical advantage devices to rotate the handwheel (pipes, wrenches, extension bars, etc.).
2. Manually position the actuator to its mid-stroke position.
3. Apply the correct power to the unit.
4. Measure the correct power and polarity on terminals 1 and 2 at the main terminal block.
5. Command the field device to generate a CCW signal. The actuator rotates in a CCW direction (as viewed from above).
6. Measure terminals 2 and 6 (run CCW) for correct voltage (matching that measured in step 4).
7. The actuator will stop when it reaches its fully CCW (90°) position.
8. With a field command signal still present, measure terminals 2 and 5, ensuring the voltage reading matches that measured in step 4.
9. Ensure continuity between terminals C and D to show that the CCW auxiliary switch is closed.
10. Command the field device to generate a CW signal. The actuator rotates in a CW direction (as viewed from above).
11. Measure terminals 2 and 4 (run CCW) for correct voltage, matching that measured in step 4.
12. The actuator will stop when it reaches its fully CW (0°) position.
13. With a field command signal still present, measure terminals 2 and 3, ensuring the voltage reading matches that measured in step 4.
14. Ensure continuity between terminals A and B to show that the CW auxiliary switch is closed.
15. Generate a mid-position signal at the field device to move the actuator off its fully CW trip position.
16. Return the field control to automatic mode.
17. The actuator is now commissioned and operational.

8.2 Commissioning Procedure for Proportional Control

⚠ WARNING - **Allowing the motor to drive the gear train into the mechanical stop will result in severe damage to the actuator!** Remove power from this device before making any travel adjustments.

After completing all mounting and wiring procedures, and main power is available, it is now possible to commission the actuator.

1. Utilize the handwheel or override shaft to rotate the actuator and damper, valve, or other connected device through its fully travel from fully CW (0°) to fully CCW (90°), and back again, to check for any possible interference. Do not utilize any mechanical advantage devices to rotate the handwheel (pipes, wrenches, extension bars, etc.).
2. Manually position the actuator to its mid-stroke position.
3. Apply the correct power to the unit, referencing the proper wiring diagram (**Error! Reference source not found.**).
4. Measure the correct power and polarity on terminals 1 and 2 at the main terminal block.
5. Command the field device to generate a 20 mA (10 VDC) signal. The actuator output shaft rotates in a CCW direction (as viewed from above) and stops at the fully CCW (90°) position.
6. Measure terminals 5 (+) and 6 (-) to read 20 mA (10 VDC).
7. Ensure continuity between terminals C and D to show the CCW auxiliary switch is closed.
8. Command the field device to generate a 4 mA (2 VDC) signal. The actuator output shaft rotates in a CW direction (as viewed from above) and stops at the fully CW (0°) position.
9. Measure terminals 5 (+) and 6 (-) to read 4 mA (2 VDC).
10. Ensure continuity between terminals A and B to show the CW auxiliary switch is closed.
11. Generate a 12 mA (6 VDC) signal at the field device to move the actuator to its mid-travel position.
12. The actuator stops at 50%, and feedback measures 12 mA (6 VDC) ± tolerance error (single decimal), if any.
13. Return the field control to automatic mode. The actuator is now commissioned and operational.

8.3 Commissioning LL Control Station On/Off Control

⚠ WARNING - **Allowing the motor to drive the gear train into the mechanical stop will result in severe damage to the actuator!** Remove power from this device before making any travel adjustments.

1. After the actuator and valve (damper) assembly have been installed with power and control connected, **before** applying power, **use the handwheel to rotate the actuator to a mid-travel position.**
2. **Place the LCS mode switch in the OFF position,** and apply power.
 - a. The actuator should not move.
 - i. If it does move, **immediately remove power from the actuator to stop movement.**
 - ii. If it does not move, proceed to step 3.
 - iii. Check the control wiring on terminals 4 – N on the actuator, correct if necessary, and repeat step 2.
3. Place the LCS move switch in the STOP position, and place the mode switch in the LOCAL position.
 - a. The actuator should not move.
4. Place the LCS move switch in the CW (0°) position, and verify that the direction of the position indicator is CW.
 - a. On LTQ008-203 Series units, during CW travel movement, depress the lever on the upper torque switch to interrupt the movement of the actuator, as a check of the system.
 - b. While traveling to the fully CW (0°) position, the CLOSE LED will be flashing.
 - c. When the actuator reaches its fully CW (0°) end-of-travel position, the CLOSE LED indicator will stay illuminated on the face of the LCS.
 - d. Place the LCS move switch in the CCW (90°) position, and verify that the direction of the position indicator is CCW.
 - e. On LTQ008-203 Series units, during CCW travel movement, depress the lever on the lower torque switch to interrupt the movement of the actuator, as a check of the system.
 - f. While traveling to the fully CCW (90°) position, the OPEN LED will be flashing.

- g. When the actuator reaches its fully CCW (90°) end-of-travel position, the OPEN LED indicator will stay illuminated on the face of the LCS.
- 5. Place the move switch in the CW (0°) position, and drive to approximately mid-travel, then stop.
- 6. Ensure that there are no remote movement commands active, and place the LCS mode switch in the REMOTE position.
 - a. The actuator should not move.
 - i. If it does move, **immediately remove power from the actuator to stop movement.**
 - ii. Check the control wiring on terminals 4 – N on the actuator, correct if necessary and repeat step 6.
- 7. Generate a remote CW move command, and verify the direction of the position indicator is CW.
 - a. If it is, proceed to step 9.
- 8. Check the field wiring:
 - a. Disconnect power.
 - i. Remove the field wiring to terminals 6, 7, and 8.
 - ii. Place a jumper between terminals 6 and 7. Do not apply external power to any of these terminals.
 - b. Reapply power. The actuator will move CW.
 - c. After confirmation, remove the jumper and reconnect the field wiring between terminal 6 and 7 only.
 - d. Generate a remote CW move command, and verify that the direction of the position indicator is CW.
 - e. Reconnect the field wiring to terminal 8.
- 9. Generate a remote CCW move command, and verify that the direction of the position indicator is CCW.
 - a. If it is CCW, proceed to step 11.
- 10. Check the field wiring:
 - a. Disconnect power.
 - i. Remove the field wiring to terminals 6 and 8.
 - ii. Place a jumper between terminals 6 and 8. Do not apply external power to any of these terminals.
 - b. Reapply power. The actuator will move CCW.
 - c. After confirmation, remove the jumper and reconnect the field wiring to terminals 6 and 8.
 - d. Generate a remote CCW move command, and verify that the direction of the position indicator is CCW.
- 11. If the actuator does not stop at the correct position(s), fails to move in the correct direction(s), or fails to stop moving when the respective torque switch levers are depressed, **immediately stop the operation of the actuator**, and refer to the Table of Contents for the section to reference for the corrective action needed.
- 12. Place the LCS in LOCAL or REMOTE mode to put the actuator into service.

8.4 Commissioning LL Control Station Proportional Control



WARNING - Allowing the motor to drive the gear train into the mechanical stop will result in severe damage to the actuator! Remove power from this device before making any travel adjustments.

1. After the actuator and valve (damper) assembly have been installed with power and control connected, **before** applying power, **use the handwheel to rotate the actuator to a mid-travel position.**
2. Set the control signal selection jumpers.
3. Place the LCS mode switch in the OFF position, and apply power.
 - a. The actuator should not move.
 - i. If it does move, **immediately remove power from the actuator to stop movement.**
 - ii. If it does not move, proceed to step 4.
 - iii. Check the control wiring on terminals 4 – N on the actuator, correct if necessary, and repeat step 3.
4. Place the LCS move switch in the STOP position, and place the mode switch in the LOCAL position.
 - a. The actuator should not move.
5. Place the LCS move switch in the CW (0°) position, and verify that the direction of the position indicator is CW.
 - a. On LTQ008-203 Series units, during CW travel movement, depress the lever on the upper torque switch to interrupt the movement of the actuator, as a check of the system.
 - i. When depressing the torque switch lever, the FAULT LED will illuminate on the face of the LCS.
 - b. While traveling to the fully CW (0°) position, the CLOSE LED will be flashing.

- c. When the actuator reaches its fully CW (0°) end-of-travel position, the CLOSE LED indicator will stay illuminated on the face of the LCS.
6. Place the LCS move switch in the CCW (90°) position, and verify that the direction of the position indicator is CCW.
 - a. On LTQ008-203 Series units, during CCW travel movement, depress the lever on the lower torque switch to interrupt the movement of the actuator, as a check of the system.
 - i. When depressing the torque switch lever, the FAULT LED will illuminate on the face of the LCS.
 - b. While traveling to the fully CCW (90°) position, the OPEN LED will be flashing.
 - c. When the actuator reaches its fully CCW (90°) end-of-travel position, the OPEN LED indicator will stay illuminated on the face of the LCS.
7. Place the move switch in the CW (0°) position and drive to approximately mid-travel, then stop.
8. Generate a mid-travel command (12 mA), then place the LCS mode switch in the REMOTE position.
 - a. The REMOTE LED will illuminate on the face of the LCS.
 - b. The actuator should move only to match the incoming signal, if at all.
 - i. If the actuator moves, and continues to move away from the midpoint, **immediately remove power from the actuator to stop movement.**
 1. Manually position the actuator back to a mid-travel position.
 2. Place a meter in series with terminal 4 (signal IN) and the wire coming from the field controller (+), ensuring a reading of +12 mA.
 - a. If it does not read +12 mA, check the polarity of the incoming analog signal to ensure a reading of +12 mA. Repeat step 8.
 - ii. If the actuator moves momentarily and stops at the mid-stroke position, proceed to step 9.
 - iii. If the actuator does not move at all, rotate the handwheel slightly in either direction to offset the controller.
 1. The actuator should move back to the midpoint position and stop. Proceed to step 9.
9. Generate a CW move command (4 mA), and verify that the direction of the position indicator is CW.
 - a. The actuator should run CW until it reaches its CW end-of-travel position.
 - b. The CLOSE LED indicator on the front of the panel should illuminate.
 - c. While power is on, an analog feedback signal out provides an electronic position of the actuator (i.e., 4 mA is fully CW and 20 mA is fully CCW - reference terminals 6 and 7).
10. Generate CCW move command (20 mA), and verify that the direction of the position indicator is CCW.
 - a. The actuator should run CCW until it reaches its CCW (90°) end-of-travel position.
 - b. The OPEN LED indicator on the front of the panel should illuminate.
 - c. While power is on, an analog feedback signal out provides an electronic position of the actuator (i.e., 4 mA is fully CW and 20 mA is fully CCW).
11. If the actuator does not stop at the correct position(s), fails to move in the correct direction(s), or fails to stop movement when the respective torque switch levers are depressed, **immediately stop the operation of the actuator**, and refer to the Table of Contents for the section to reference for the corrective action needed.
12. Place the LCS in LOCAL or REMOTE mode to put the actuator into service.

8.5 Connecting and Starting the Battery System

After the actuator has been fully installed in the field and wired to power and control systems, the unit is ready to initialize the battery system. The procedure is as follows:

1. Remove the actuator top cover.
2. Locate the green two-pin connector halves.
 - a. Both halves are keyed to connect in only one direction.
 - b. Align with each other and plug together.
3. Apply 24V power to the actuator.
4. Replace the actuator top cover.
5. Battery system must charge for 12 hours after powering up to provide 100% charge capacity.
6. The battery system employs a 22.2V Lion pack. The DC motor is driven directly by the battery pack upon loss of power. Refer to pg 36 for setting the required fail safe direction (default is drive CW on loss of power).

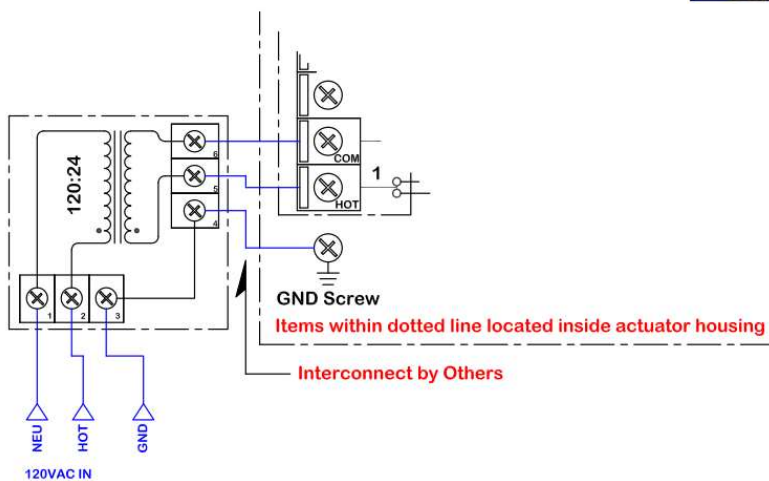
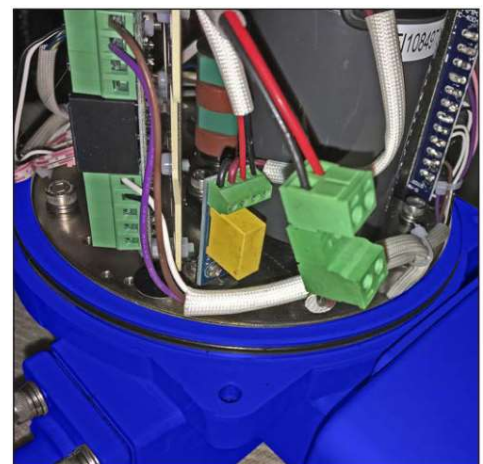

Figure 31: Wiring from optional power supply

9 Calibration

9.1 Calibration Procedure for On/Off Control

⚠ WARNING - Allowing the motor to drive the gear train into the mechanical stop will result in severe damage to the actuator! Remove power from this device before making any travel adjustments.

After completing all mounting and wiring procedures, and main power is available, it is now possible to commission the actuator.

1. Apply the correct power according to the actuator model and the respective wiring diagram (**Error! Reference source not found.**).
2. Position the actuator to its fully CW (0°) or fully CCW (90°) position, adjusting the cam as necessary (see Section 7,
3. After making cam adjustments on either or both ends-of-travel, it is advisable to move off the cam slightly then repeat the drive command to assure the cam settings are correct.
4. Ensure that the cam set screws are snug but not overtight; overtightening during calibration will make it difficult to make minor, incremental adjustments.
5. The unit is now calibrated and is ready for immediate operation. No further calibration is necessary.

9.2 Calibration Procedure for Proportional Control (120 – 230 VAC Models)

⚠ WARNING - Allowing the motor to drive the gear train into the mechanical stop will result in severe damage to the actuator! Remove power from this device before making any travel adjustments.

After completing all mounting and wiring procedures, and main power is available, it is now possible to commission the actuator. Before applying power or making wiring connections:

1. Set the gear train in the fully CW (0°) position.
2. Set cams 1, 3, and 5 according to the on/off procedure.
3. Set the gear train in the fully CCW (90°) position.
4. Set cams 2, 4, and 6 according to the on/off procedure.
5. Set the gear train back to the fully CW (0°) position.
6. Make field wiring connections for power, control, and feedback signals, referring to the correct wiring diagram for the product.
 - a. Connections are made **only to the main terminal block.**
 - b. **No connections are made to the proportional control board directly.**
7. Set the jumper headers for correct signal IN and OUT (see Figure).
8. Rotate the potentiometer pinion gear to its full CCW position, then back about 1.5 – 2 teeth CW before tightening the two M3 set screws on the sector drive gear.
9. Apply the correct power according to the actuator model, using the proper wiring diagram as reference.
 - a. The red PWR LED will turn on.
10. Press the “Calibrate” black push-button on the Mod control board (Figure), and hold it down for about three seconds, then release.



Figure 32: Alignment of the sector and potentiometer gear set at the fully CW position (see step 8).

- a. The unit will run to its full CCW (90°) position, stop for a few seconds, then run back to its fully CW (0°) position.
- 11. After a few seconds, the unit will complete the calibration routine and return to active operation mode by responding to the incoming 4 – 20 mA control signals being sent to the actuator.
- 12. Slight adjustments may be made to the 4 mA and 20 mA trimmers to affect the accuracy of the feedback signal as a function of actuator position.
- 13. The units is now calibrated and ready for immediate use. No further calibration is necessary.

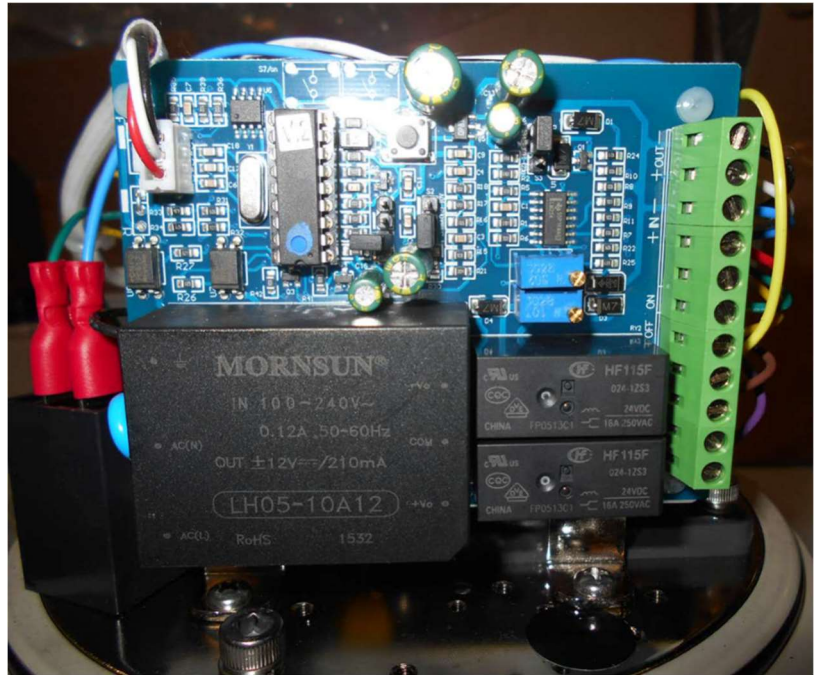
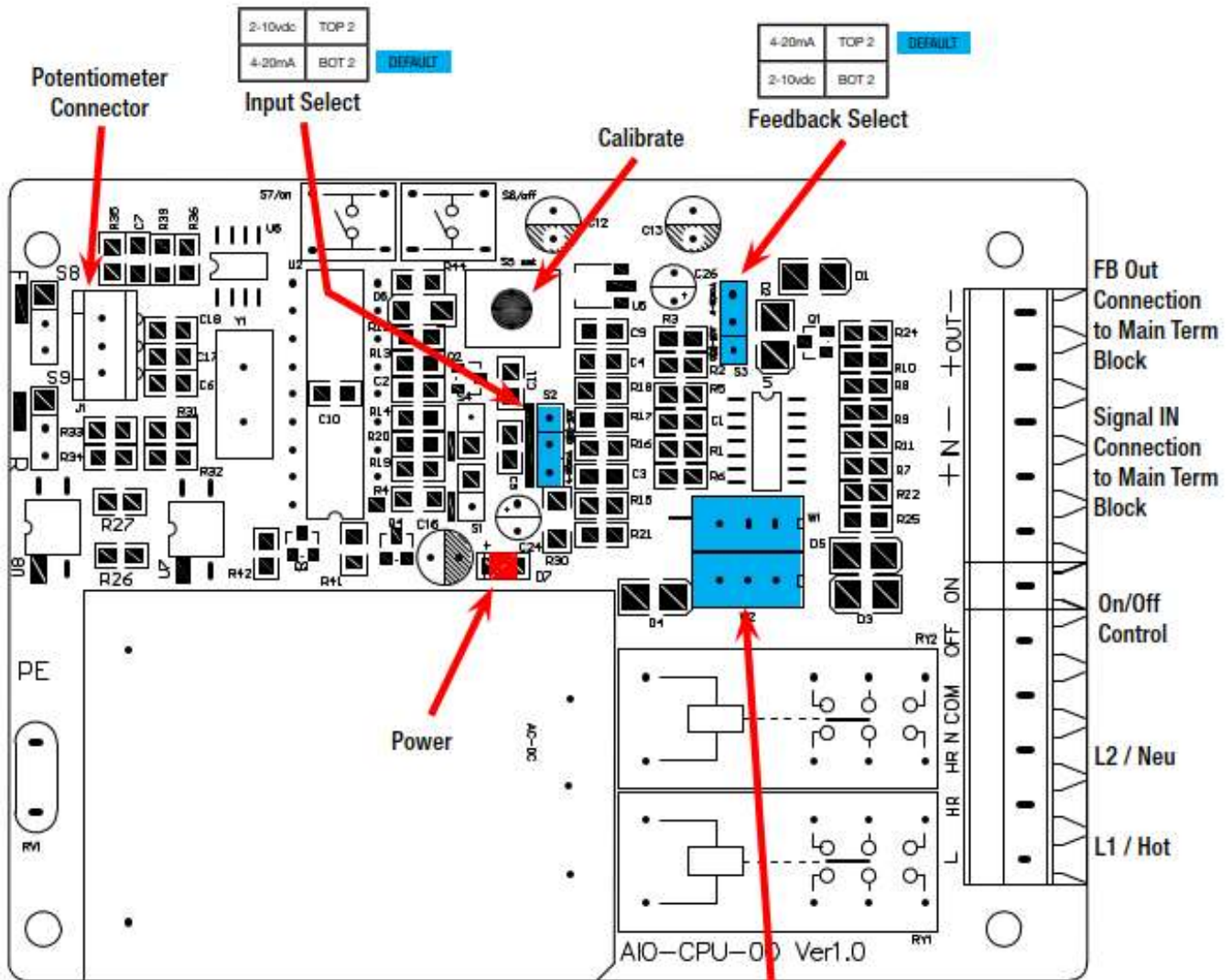

Figure 33: Proportional PCB single-phase (120 – 230 VAC models)



Make all connections to the MAIN terminal block ONLY!

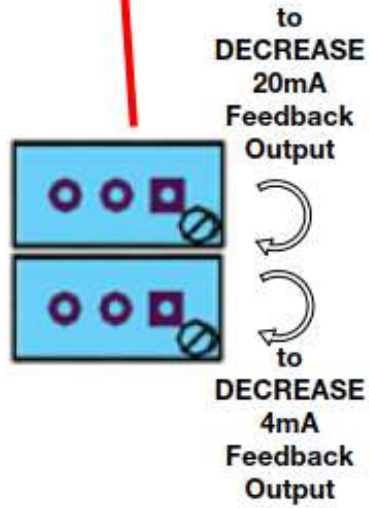

Figure 34: Proportional PCB details single-phase (120 – 230 VAC models)

9.3 Calibration Procedure for Proportional Control (12 – 24 VAC/VDC Models)

⚠ WARNING - Allowing the motor to drive the gear train into the mechanical stop will result in severe damage to the actuator! Remove power from this device before making any travel adjustments.

After completing all mounting and wiring procedures, and main power is available, it is now possible to commission the actuator. Before applying power or making any wiring connections:

2. Set the gear train in the fully CW (0°) position.
3. Set cams 1, 3, and 5 according to the on/off procedure.
4. Set the gear train in the fully CCW (90°) position.
5. Set cams 2, 4, and 6 according to the on/off procedure.
6. Set the gear train back to the fully CW (0°) position.
7. Make field wiring connections for power, control, and feedback signals, referring to the correct wiring diagrams for the product.
 - a. Connections are made **only** to the main terminal block.
 - b. **No connections are made to the proportional control board directly.**
8. Set the DIP switches for correct signal IN and OUT (see Figure).
9. Rotate the potentiometer pinion gear to its fully CCW position, then back about 1.5 – 2 teeth CW before tightening the two M3 set screws on the sector drive gear.
10. Apply correct power according to the actuator model.
 - a. The blue LED D1 will turn on, and the green LED STA will turn on.
11. Press the “SET” black push-button on the Mod control board, and hold it down for about three seconds, then release.
 - a. The green STA LED will turn off, and the unit will drive to the fully CCW (90°) position and stop when the pre-set cam positions are reached.



Figure 35: Alignment of the sector and potentiometer gear set at the fully CW position (see step 8).

NOTICE - There are no LED indicators to indicate when the actuator is running.

12. When the actuator stops, press the “OP” black push-button **once**.
 - a. The actuator will drive to its fully CW (0°) position, stopping when the pre-set cam positions are reached.
13. When the actuator stops, press the “CL” black push-button **once**.
14. The unit will start to respond to the incoming 4 – 20 mA control signal being sent to the actuator.
15. Slight adjustments may be made to trimmer VR2 if necessary to tune the feedback signal.
16. The unit is now calibrated and ready for immediate use. No further calibration is necessary.

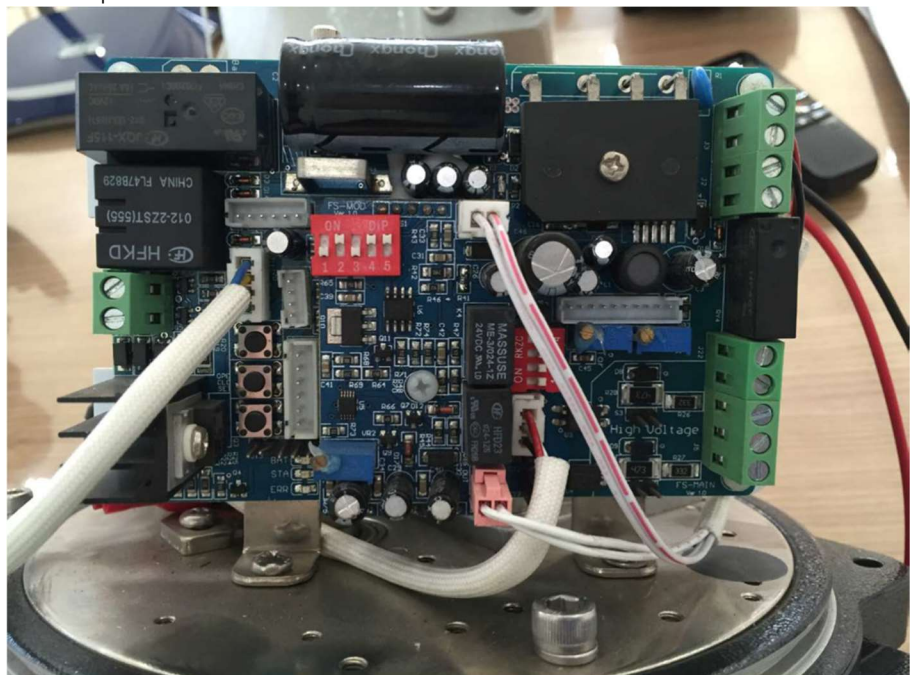
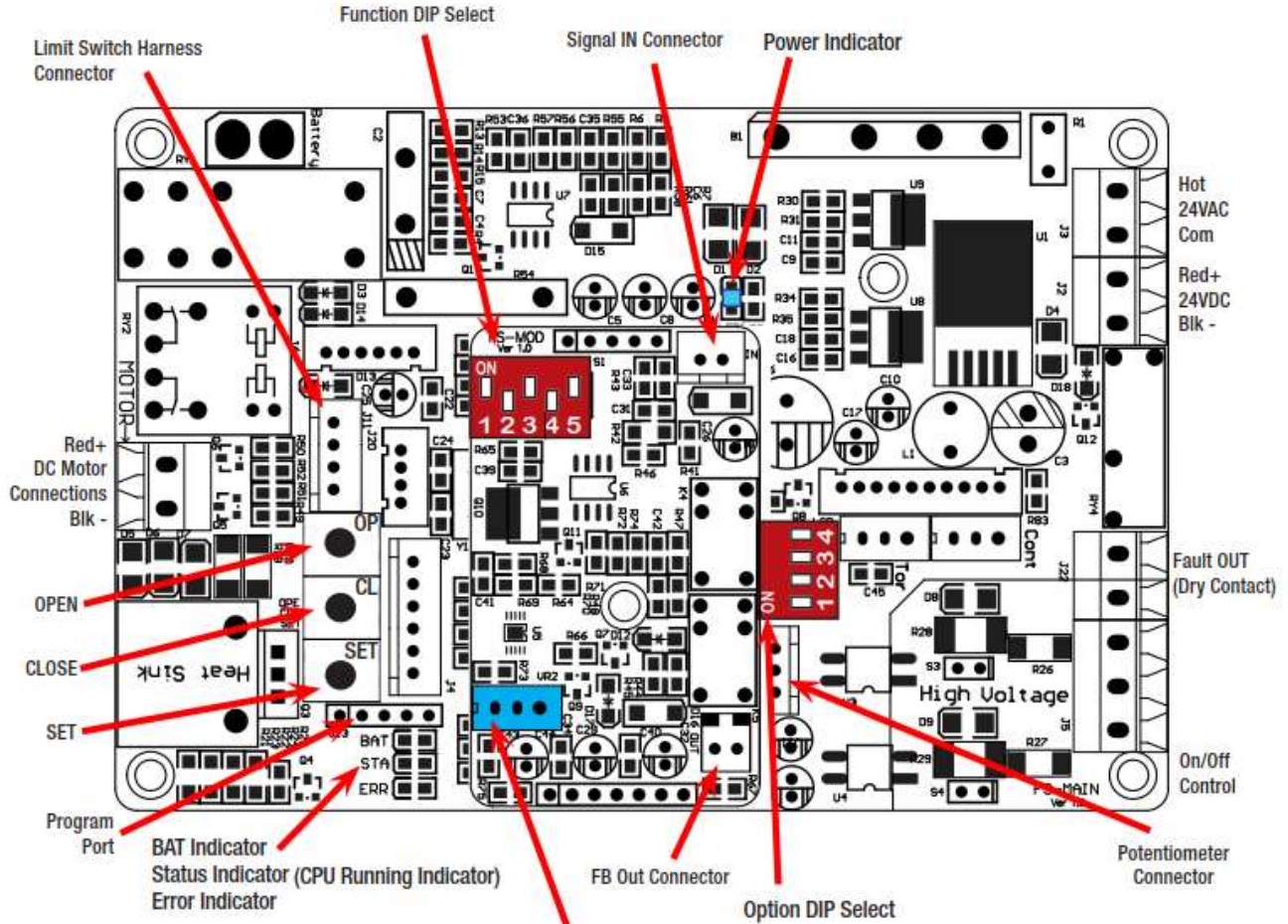

Figure 36: Proportional PCB single-phase (12 - 24 VAC/VDC models)

Function DIP Select Table DEFAULT

DIP	ON	OFF	FUNCTION
1	4-20mA	0(2)-10V	Input
2	0-10V	2-10V/4-20mA	
3	4-20mA	0(2)-10V	Feedback
4	0-10V	2-10V/4-20mA	
5	Mod	On/Off	Control



Indicators Table

FUNCTION	COLOR	STATUS
Power Indicator	Blue	LED ON = Mains Power ON
		LED OFF = Mains Power OFF
BAT Indicator	Yellow	LED OFF = Battery Disconnected
		LED ON = Battery Charge Sufficient
		LED Flashing = Battery Charging
Status Indicator	Green	LED ON = System CPU Running
		LED OFF = System Stopped - Fault
Error Indicator	Red	LED OFF = Normal
		LED ON = Fault (Fault OUT Contact tripped)

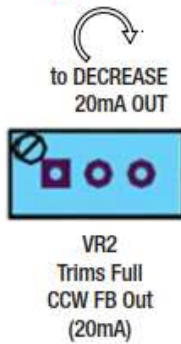

Option DIP Select Table

DEFAULT

DIP	FUNCTION - Proportional Failsafe Models
4 = Off	Factory Function
4 = On	Factory Function
3 = Off	Direct Acting (DA) Mode (4mA = Closed CW)
3 = On	Reverse Acting (RA) Mode (20mA = Closed CW)
1 = Off, 2 = Off	Fully CW upon loss of mains power (independent of DIP 3)
1 = Off, 2 = On	Invalid
1 = On, 2 = On	Fully CCW upon loss of mains power (independent of DIP 3)

Figure 37: Proportional PCB details single-phase (120 - 230 VAC models)

9.4 Calibration Procedure for LL Control Station Proportional Control

After completing all mounting and wiring procedures, and main power is available, it is now possible to commission the actuator.

1. Position the actuator to a mid-stroke position.
2. Apply correct power according to the actuator model.
3. Press the S1 button on the control board for 5 seconds, the blue light (D18) turns the red light (D3) turns off. The system then enters the stroke setting mode.
4. First, set the full CW stroke position.
 - a. Under the full CW setting mode, press S3 button for the actuator to move CW.
 - b. Press S3 to move CW until the actuator reaches full CW position and then release the button.
 - c. Press S1 button for 5 seconds, the blue light (D18) and red light (D3) both turn on.
 - d. The MCU will record the CW (0%) position, and then enters the full CCW setting mode.
5. Set the full CCW stroke position.
 - a. Press S2 button for the actuator to move CCW.
 - b. Continue to pressing S2 towards 100% until the actuator reaches full CCW position and then release the button to stop.
 - c. Press S1 button for 5 seconds, blue light (D3) turns off and the red light (D3) turns on.
 - d. The MCU will record the CCW (100%) position.
6. Setting is done.
7. Note: The actuator has a blocked protection function. When stroke block occurs for over 10 seconds, the system goes into lock mode and stops the stroke movement. If it happens during the stroke setting, move the stroke towards the opposite direction to unlock. For example if it happens at 0% position, direct the stroke towards 100% to release the block protection.
8. On/Off Control stops here, Calibration is complete.



Figure 38: Alignment of the sector and potentiometer gear sets at the fully CW position (ref. only).

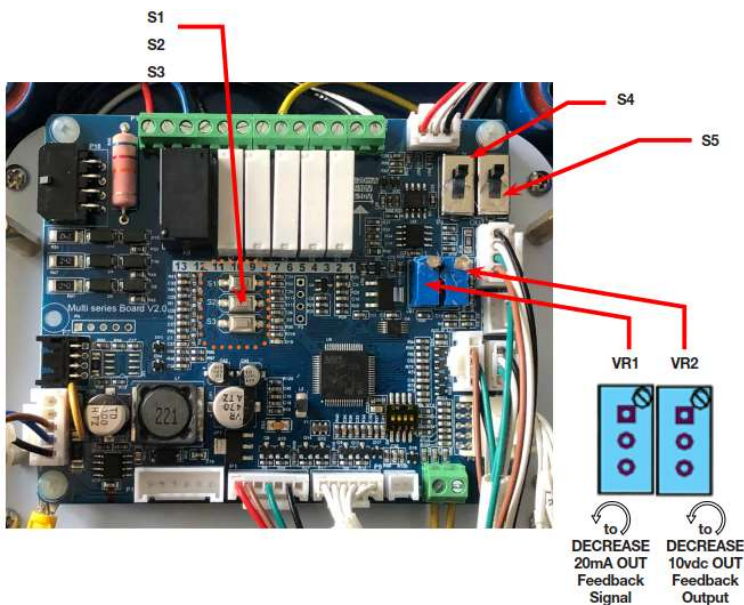

Signal Switch Selections			DEFAULT	
Signal Type		Input Signal		Output Signal
		S4	S5	S5
Current	4-20mA			
	2-10V			
Voltage	0-10V			

Figure 39: Proportional LL 3-phase (24 V controller)

9.5 Calibration Procedure for On/Off with Battery Backup

⚠ WARNING

- Follow these directions carefully and in order. Actuator damage due to improper testing and commissioning will NOT be covered under warranty.

After completing all mounting and wiring procedures and main power is available, it is now possible to commission the actuator.

1. Before applying power or making any wiring connections:
2. Set the geartrain in the full CW position.
3. Set the #1, #3 and #5 cams according to the on/off procedure.
4. Set the unit in the full CCW position.
5. Set the #2, #4 and #6 cams according to the on/off procedure.
6. Set the geartrain back to the fully closed (CW) position.
- 7. If the alignment of the potentiometer gearset does not look like the photo at right, contact technical services.**
8. Make your field wiring connections for power, control and feedback signals, referring to the correct wiring diagrams for your product.
 - a. Connections are made ONLY TO THE MAIN TERMINAL BLOCK.
 - b. No connections are made to the on/off control board directly.
9. Apply correct power according to the actuator model.
 - a. The blue LED D1 will turn on, and grn LED STA will turn on.
10. Press the "SET" black pushbutton on the control board and hold it down for about three seconds, then release.
 - a. The grn STA LED will turn off and the unit will drive to the full CCW (Open) position and stop when the pre-set cam positions are reached. There are NO LED indicators to advise when the actuator is running.
11. When the actuator stops, press the OP pushbutton ONCE.
 - a. The actuator will drive to its full CW (Closed) position and stop when the pre-set cam positions are reached.
12. When the actuator stops, press the CL pushbutton ONCE.
13. Unit is now calibrated and is ready to be put into service. No other calibration is necessary. Proceed to Commissioning.



Figure 40: Alignment of the sector and potentiometer gear sets at the fully CW position (ref. only).

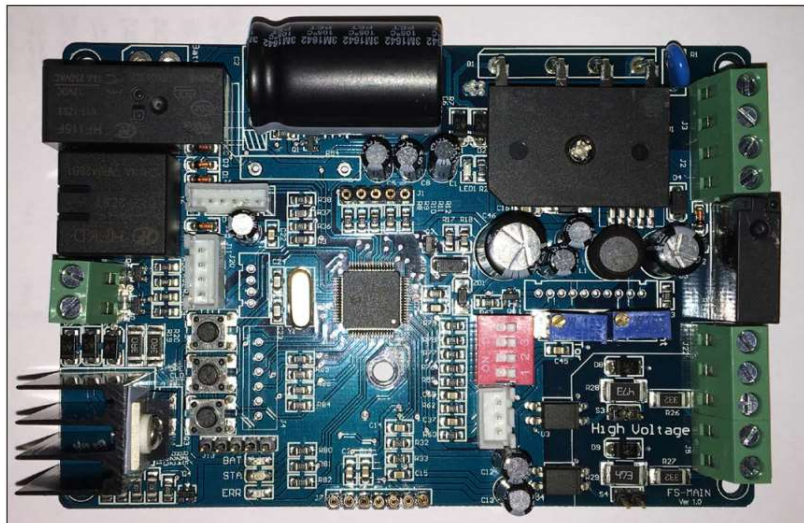
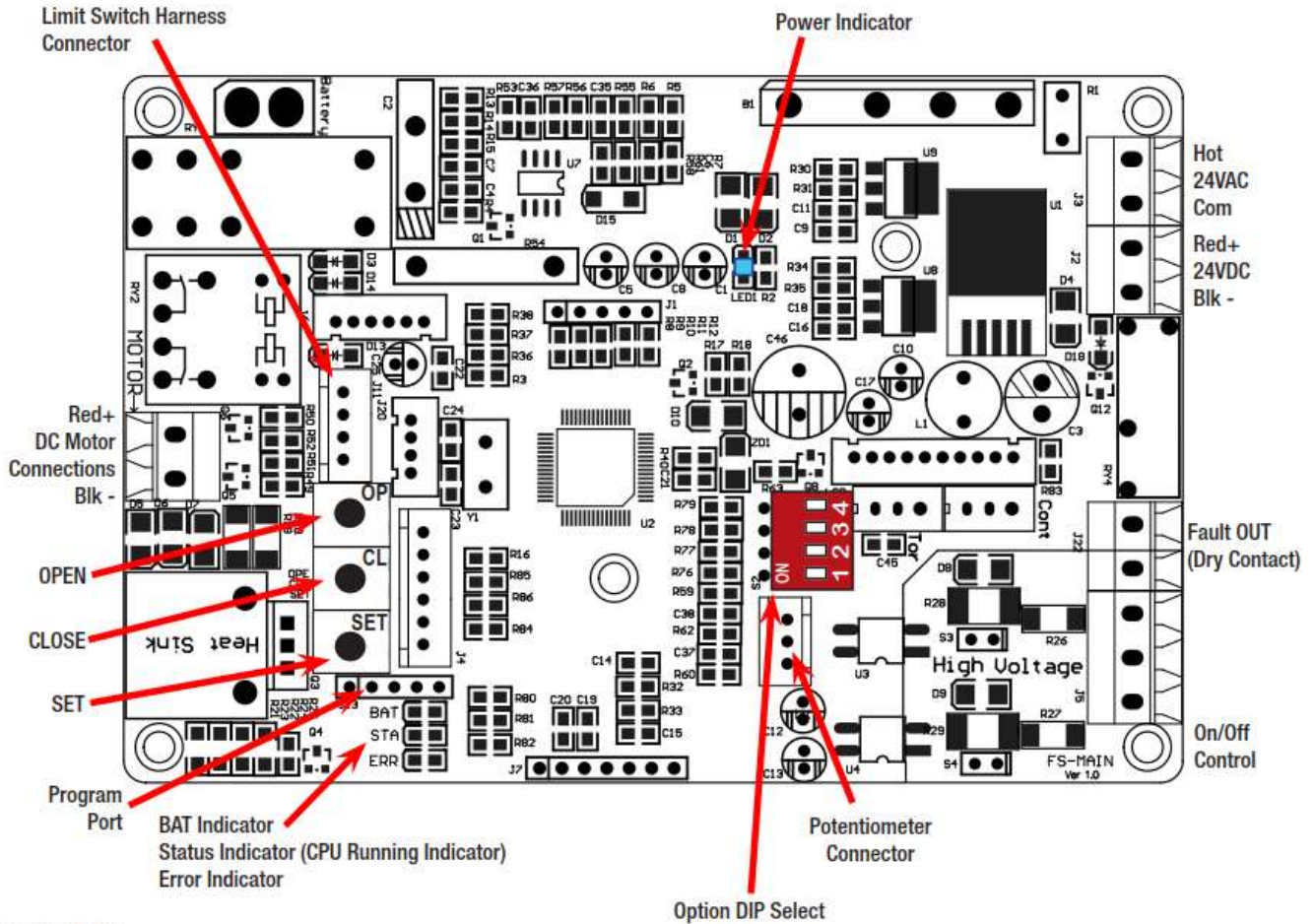

Figure 41: Battery Backup controller board for Open/Close applications



Indicators Table

FUNCTION	COLOR	STATUS
Power Indicator	Blue	LED ON = Mains Power ON
		LED OFF = Mains Power OFF
BAT Indicator	Yellow	LED OFF = Battery Disconnected
		LED ON = Battery Charge Sufficient
		LED Flashing = Battery Charging
Status Indicator	Green	LED ON = System CPU Running
		LED OFF = System Stopped - Fault
Error Indicator	Red	LED OFF = Normal
		LED ON = Fault (Fault OUT Contact tripped)

Option DIP Select Table

DIP	FUNCTION - On/Off Failsafe Models	DEFAULT
4 = Off	Factory Function	
4 = On	Factory Function	
3 = Off	Direct Acting (DA) Mode (Wiring Terminal #4 = CW)	
3 = On	Reverse Acting (RA) Mode (Wiring Terminal #6 = CW)	
1 = Off, 2 = Off	Fully CW upon loss of mains power (independent of DIP 3)	
1 = Off, 2 = On	Invalid	
1 = On, 2 = On	Fully CCW upon loss of mains power (independent of DIP 3)	

Figure 42: Battery Backup Open/Close PCB details

10 Troubleshooting Guide



- To avoid dangerous or fatal electrical shock, turn **off** power to all electrical equipment before working on electrical connections. If it is necessary to troubleshoot with live power to the actuator, use **extreme caution**, and follow all relevant company safety protocols and procedures.

After completing all mounting and wiring procedures, and main power is available, if the actuator does not respond as expected, the following procedure(s) may help in identifying the problem. If problems still exist after consulting Table and Table , contact Flowserve for additional support.

Table 2: Fault symptoms for on/off control models

The actuator does not move when commanded to do so.			
↓	The supply and controls are measured to be correct, but the actuator still does not move.		
↓	The motor is extremely hot to the touch.		
↓	The actuator does not stop at the correct position at either end-of-travel.		
↓	Target	Action	
•	Power source	Measure incoming power at the actuator terminal blocks. Reference the correct wiring diagram.	
•	Control problem	Generate move commands by the field device. Measure correct voltage changes between hot and terminal 6 (CCW) and hot and terminal 4 (CW).	
•	Wire sizing	Check for the correct wire size per section 11.4, Wire Sizing.	
•	Overtorque	Remove the actuator from the driven device. If the actuator now moves, the torque required by the mechanical device exceeds that of the actuator. Increase the size of the actuator.	
•		With the actuator removed from the mechanical equipment, manually rotate the valve or damper through its intended range of travel to check for mechanical problems.	
•	Insufficient power supply and/or incorrect wire size during installation.	Measure the voltage between terminals 1 and 2 while commanding the actuator to move. The measured voltage cannot drop more than 10% from the rated voltage.	
•	Cams improperly set.	Remove the power supply. Check to see if the cams rotate freely on the cam shaft using your finger. The cams must be secure and set according to the procedures in section 7,	
•	Control "noise" or excessive duty cycle.	Check for stray voltage fluctuations on the incoming control signals. The on/off line voltage actuators have a maximum 25% duty cycle, while the low voltage models have a 75% duty cycle.	
•		Check for parallel wiring of multiple on/off actuators. Review the site as-built wiring diagrams to verify.	
•	Travel cams and/or mechanical stops not positioned correctly.	Reset the end-of-travel cams and/or mechanical stops as detailed in section 7,	

Table 3: Fault symptoms for proportional control models

The actuator does not move when commanded to do so.			
↓ The supply and controls are measured to be correct, but the actuator still does not move.			
↓ The motor is extremely hot to the touch.			
↓ The actuator does not stop at the correct position at either end-of-travel.			
		Target	Action
●		Power source	Measure incoming power at the actuator terminal blocks. Reference the correct wiring diagram (Error! Reference source not found.).
●		Control problem	Generate move commands by the field device. For most analog control systems, reversing the polarity will render the control system output as invalid. Check the polarity of the analog control signals as they are connected to the actuator. The actuator will not respond to inverted control signals.
●		Wire sizing	Check for the correct wire size per section 11.4, Wire Sizing.
●		Overtorque	Remove the actuator from the driven device. If the actuator now moves, the torque required by the mechanical device exceeds that of the actuator. Increase the size of the actuator.
●			With the actuator removed from the mechanical equipment, manually rotate the valve or damper through its intended range of travel to check for mechanical problems.
●		Insufficient power supply and/or incorrect wire size during installation.	Measure the voltage between terminals 1 & 2 while commanding the actuator to move. The measured voltage cannot drop more than 10% from the rated voltage.
●		Cams improperly set.	Remove power. Check to see if the cams rotate freely on the cam shaft using your finger. The cams must be secure and set according to the procedures in section 7,
	●	Control "noise" or excessive duty cycle.	Check for stray voltage fluctuations on the incoming control signals. Analog control signals are susceptible to "noise" and send unstable control data to the actuator. This results in a never-ending motor drive scenario with the usual result being thermal overload of the drive motor.
	●		Check for parallel wiring of multiple on/off actuators. Review the site as-built wiring diagrams to verify.
		● Travel cams and/or mechanical stops not positioned correctly.	

Table 4: Fault symptoms for failsafe control models

Actuator does not move to expected Fail-Safe position upon loss of mains power		
↓	Actuator does not complete the move to the full end of travel position upon loss of mains	
↓	Target	Action
●	Stored Energy device not connected	After actuator commissioning, plug the two-pin green connectors together. The BAT status LED must be ON when power is On.
●	Stored Energy device not charged	Unit must charge for at least twelve hours after initial connection is made
●	Fail-Safe direction incorrectly set	Reset 4 position DIP Switch
●	Stored Energy device not sufficiently charged	Unit must charge for at least twelve hours after initial connection is made. Yellow BAT status indicator must be on or flashing when mains power is ON and stored energy device is plugged into connector.
●	Fault OUT contact is closed. ERR indicator on PCB is ON	Motor current draw exceeds the capacity of the stored energy device. Check valve torque and charge time.
		Mains power ON time is insufficient between power failures - increase ON time.
		Stored energy demand cycle has depleted the life of the device - replace stored energy pack.
●	ERR indicator is ON	Stored energy device disconnected - reconnect two-pin plug.
		Stored energy device voltage drops below 18.5VDC.

11 Technical Data

11.1 Nameplate

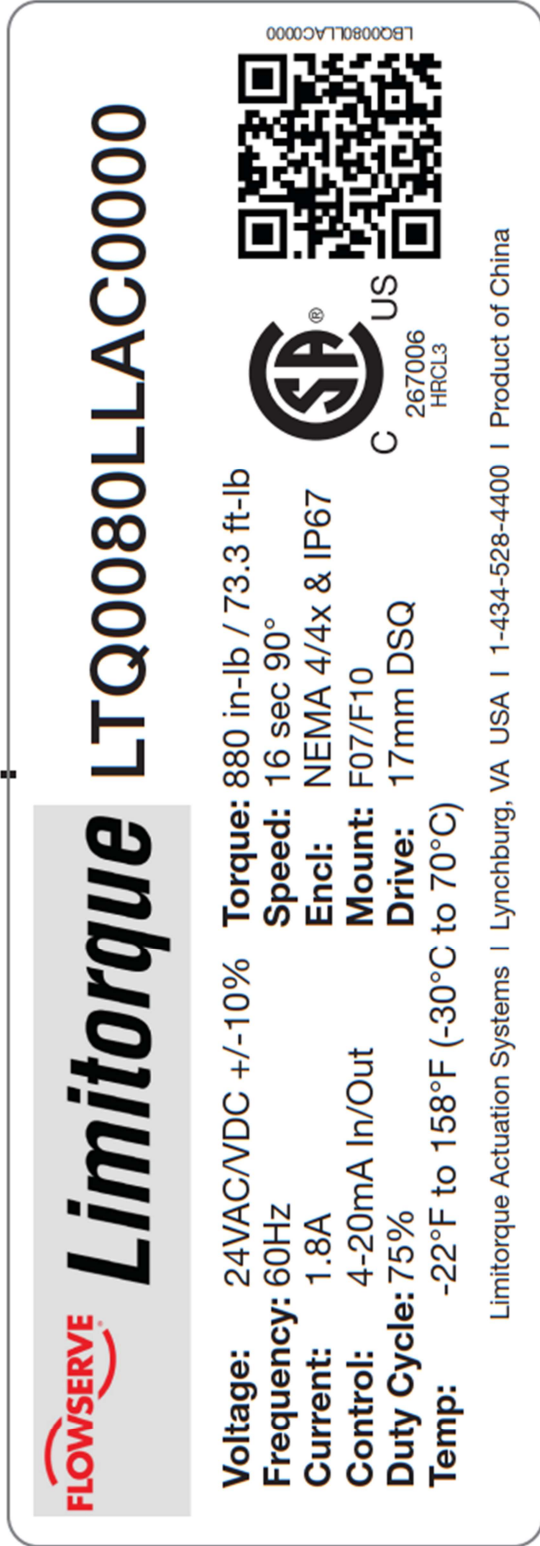

Figure 43: Example of a nameplate for LTQ008 – LTQ203 Series



11.2 Torque Requirements

Table 2: LTQ008 – LTQ203 actuator specifications

Actuator		LTQ008	LTQ017	LTQ034	LTQ053	LTQ070	LTQ088	LTQ150	LTQ203
Supply	Torque Output (in-lb / N m)	880 / 100	1770 / 200	3540 / 400	5310 / 600	7080 / 800	8850 / 1000	15040 / 1700	20350 / 2300
12VAC*	Current Draw (Start / Run / LRA)	7.2A / 5.2A / 17.8A			11.4A / 9.4A / 24.4A		-	-	-
	Speed (90°) DC – 60Hz / 50Hz (sec)	14 / 14	28 / 28	21 / 21	28 / 28	34 / 34	-	-	-
	Motor – 12V DC Brush TENV	25W		40W		-	-	-	-
12VDC*	On/Off / Proportional	Duty Cycle (IEC60034)		25% (S2 – 15min) / 75% (S4 – 75%)		-	-	-	-
		Motor Protection, Temp / Class		All – 130°C / Class B		-	-	-	-
		Motor Starts, per hour, Max		All – 600		-	-	-	-
24VAC	Current Draw (Start / Run / LRA)	4.2A / 3.2A / 11A		7.0A / 5.8A / 15A		10.5A / 7.8A / 22A		-	
	Speed (90°) DC – 60Hz / 50Hz (sec)	14 / 14	28 / 28	21 / 21	28 / 28	34 / 34	25 / 25	25 / 25	-
	Motor – 24V DC Brush TENV	25W		40W		90W		-	-
24VDC	On/Off / Proportional	Duty Cycle (IEC60034)		25% (S2 – 15min) / 75% (S4 – 75%)		-	-	-	-
		Motor Protection, Temp / Class		All – 130°C / Class B		-	-	-	-
		Motor Starts, per hour, Max		All – 600		-	-	-	-
120VAC	Current Draw (Start / Run / LRA)	1.2A / 0.9A / 1.5A		3.0A / 1.8A / 3.5A		3.8A / 2.3A / 4.8A		7.2A / 4.5A / 9.4A	
	Speed (90°) – 60Hz / 50Hz (sec)	16 / 19	33 / 39	24 / 29	33 / 39	39 / 47		28 / 34	39 / 47
	Motor – 120V Capacitor Run TENV	40W		90W		120W		200W	
	On/Off / Proportional	Duty Cycle (IEC60034)		25% (S2 – 15 min) / 75% (S4 – 75%)		25% (S2 – 15 min) / 50% (S4 – 50%)			
		Motor Protection, Temp / Class		155°C / Class F / 180°C / Class H		All – 600			
230VAC	Current Draw (Start / Run / LRA)	0.5A / 0.4A / 0.7A		1.7A / 0.9A / 1.9A		2.2A / 1.1A / 2.4A		4.1A / 2.2A / 4.5A	
	Speed (90°) – 60Hz / 50Hz (sec)	16 / 19	33 / 39	24 / 29	33 / 39	39 / 47		28 / 34	39 / 47
	Motor – 230V Capacitor Run TENV	40W		90W		120W		200W	
	On/Off / Proportional	Duty Cycle (IEC60034)		25% (S2 – 15 min) / 75% (S4 – 75%)		25% (S2 – 15 min) / 50% (S4 – 50%)			
		Motor Protection, Temp / Class		155°C / Class F / 180°C / Class H		All – 600			
All	Environmental Rating	NEMA 4/4X and IP67							
	Electrical Entry (2)	3/4" EMT or polyamide gland							
	Control	On/Off, Proportional, 2 Pos RO, RC, and 3 Position							
	Auxiliary Switch – End-of-Travel	(4) Form A Volt-Free, Rated 1A @ 24V							
	Ambient Operating Range	-22°F to +158°F (-30°C to +70°C)							
	Humidity Range	0 – 95% RH							
Altitude Limit	9850 ft / 3000 m								
Battery Specs.	Type	Lithium Ion 22.2v pack with charge / discharge control							
	Cell Arrangement	Bank of 8 (eight) x 2.8V w/ logic control							
	Service Life - @ Rated Torque Cycle Drain	10,000 cycles @ 5% Stored energy drain per cycle							
	Enclosure	6 x 4 x 4, Aluminum enclosure		Entire Battery System under Main Cover					

11.3 Exploded View of LTQ008 – LTQ203 Units

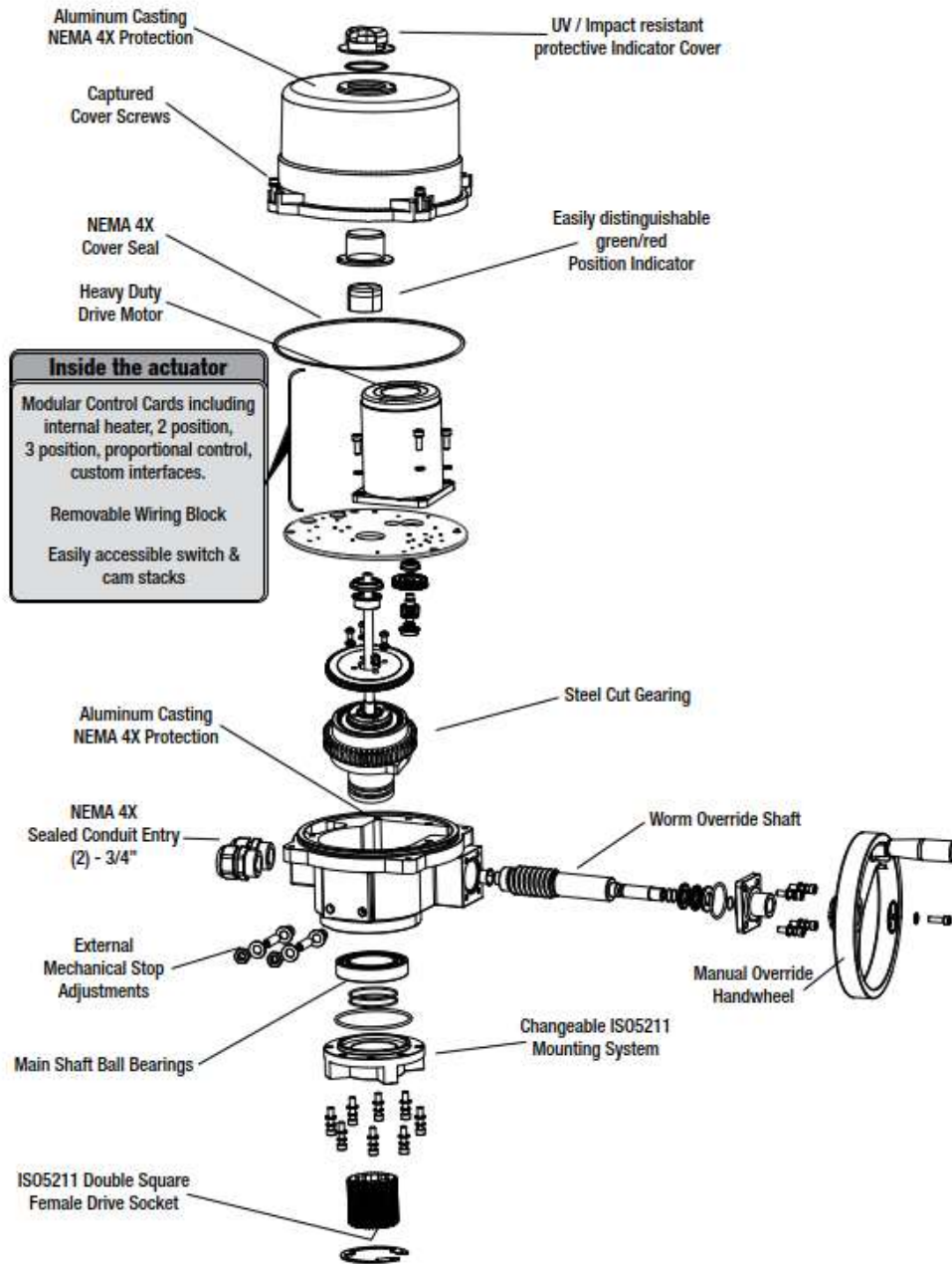

Figure 44: Exploded view of the LTQ008 – LTQ017 units



11.4 Wire Sizing

Wire sizing data is provided below to assist in the selection of the proper wire size for LTQ008 Series actuators using various wire sizes over distance. Always reference the correct voltage, and do not exceed the indicated length of the wire run for each model.

Table 6: Maximum distance between the actuator and power supply (ft) for 12 VAC/VDC units*

Actuator		LTQ008 – LTQ017	LTQ034 – LTQ070
Voltage		12 VAC/VDC	12 VAC/VDC
AWG	Amps	7.2	11.4
18		-	-
16		-	-
14		30	-
12		48	30
10		76	48
8		121	76

*No LTQ088 – LTQ203 options available

Table 7: Maximum distance between the actuator and power supply (ft) for 24 VAC/VDC units*

Actuator		LTQ008 – LTQ017	LTQ034 – LTQ070	LTQ088 – LTQ150
Voltage		24 VAC/VDC	24 VAC/VDC	24 VAC/VDC
AWG	Amps	4.2	7.0	10.5
18		41	-	-
16		65	-	-
14		103	6.2	-
12		164	98	65
10		260	156	104
8		414	248	165

*No LTQ203 option available

Table 8: Maximum distance between the actuator and power supply (ft) for 120 VAC units

Actuator		LTQ008 – LTQ017	LTQ034 – LTQ070	LTQ088	LTQ150 – LTQ203
Voltage		120 VAC	120 VAC	120 VAC	120 VAC
AWG	Amps	1.2	3.0	3.8	7.2
18		712	285	225	-
16		1132	453	357	-
14		1800	720	568	300
12		2862	1145	904	477
10		4550	1820	1437	758
8		7238	2895	2286	1206



Table 9: Maximum distance between the actuator and power supply (ft) for 230 VAC units

Actuator		LTQ008 – LTQ017	LTQ034 – LTQ070	LTQ088	LTQ150 – LTQ203
Voltage		230 VAC	230 VAC	230 VAC	230 VAC
AWG	Amps	0.5	1.7	2.2	4.1
18		3275	963	744	399
16		5206	1531	1183	635
14		8281	2436	1882	1010
12		13167	3873	2992	1606
10		20930	6156	4757	2552
8		33295	9793	7567	4060



Annex A: Glossary

Below are terms and definitions used throughout this manual:

1. **BAS** is an industry acronym for a building automation system.
2. **BIC** is an industry acronym for basic integral controls.
3. **CCW** denotes the counter-clockwise direction for movement.
4. **CW** denotes the clockwise direction for movement.
5. **F.C.** denotes the operational status of the actuator when fully closed.
6. **F.O.** denotes the operational status of the actuator when fully opened.
7. **FS** denotes a product manufactured with fail safe built-in.
8. **LCS** is an industry acronym for a local control station.
9. **MCC** is an industry acronym for a motor control center.
10. **NCU** is an industry acronym for no controls units.
11. **PC** denotes a product manufactured with phase correction circuitry built-in.
12. **PCB** is an industry acronym for printed circuit board.
13. **PLC** is an industry acronym for a programmable logic controller.
14. **PP** denotes a product manufactured with phase protection circuitry built-in.
15. **REV** denotes a product manufactured with reversing motor starters built-in.
16. **TS** denotes a product manufactured with torque switches.
17. **VAC** is an industry acronym for volts alternating current.
18. **VDC** is an industry acronym for volts direct current.
19. **XFS** denotes a product manufactured without fail safe built-in.
20. **XLCS** denotes a product manufactured without a local control station.
21. **XPP** denotes a product manufactured without phase protection circuitry built-in.
22. **XREV** denotes a product manufactured without reversing motor starters built-in.
23. **XTS** denotes a product manufactured without torque switches.



Flowserve factory contacts:

United States

Flowserve Corporation

5114 Woodall Road
Lynchburg, VA 24502-2248
Phone: 1 434 528 4400
Fax: 1 434 845 9736

United States

Flowserve Corporation

14219 Westfair West Drive
Houston, TX 77041-1137
Phone: 1 281 671 9209
Fax: 1 281 671 9268
Email: vachouston@flowserve.com

Local Flowserve representative:

To find your local Flowserve representative use the Sales Support Locator System found at www.flowserve.com.

Flowserve Corporation has established industry leadership in the design and manufacture of its products. When properly selected, this Flowserve product is designed to perform its intended function safely during its useful life. However, the purchaser or user of Flowserve products should be aware that Flowserve product might be used in numerous application under a wide variety of industrial service conditions. Although Flowserve can (and often does) provide general guidelines, it cannot provide specific data and warnings for all possible applications. The purchaser/user should read and understand the User Instructions: Installation Operation Maintenance included with the product, and train its employees and contractors in the safe use of Flowserve products in connection with its application

While the information and specifications contained in this literature are believed to be accurate, they are supplied for informative purpose only and should not be considered certified or as a guaranteed of satisfactory results by reliance thereon. Nothing contained herein is to be construed as a warranty or guarantee, express or implied, regarding any matter with respect to the product. Because Flowserve is continually improving and upgrading its product design, the specifications, dimensions and information contained herein are subject to change without notice. Should any question arise concerning these provisions, the purchaser/user should contact Flowserve Corporation at any one of its worldwide operations or offices.

© 2017 Flowserve Corporation, Irving, Texas, USA. Flowserve is a registered trademark of Flowserve Corporation

