

Worcester® RB Series Declutchable Manual Override

The Worcester RB Series declutchable manual override sandwich-mounts between the actuator and the valve or damper. The self-locking, declutchable worm gear design provides a secure, easily engaged, long-lasting override for Worcester Series F39 actuators. The RB Series manual override is direct-mounted to the actuator for a low-profile design. The override contains internal travel stops, which allow for the valve to be independently operated with the actuator removed.



Features

- 1. Sandwich mounting** — The RB Series declutchable manual override is sandwich-mounted between the actuator and valve/damper for a low-profile design.
- 2. Travel stops** — The RB Series declutchable manual override has internal travel stops, which allow for the valve to be independently operated with the actuator removed.
- 3. Self-locking declutch mechanism** — The declutch handle is securely held in place by a spring-loaded lock pin to ensure gear engagement or disengagement.
- 4. Corrosion-resistant material** — The aluminum cast body has a black epoxy coating for use in wet and corrosive environments.
- 5. Gear plating** — The output gear and worm gear are plated for long-term reliability and service life.

Materials of construction

Part	Material
Housing and Cover	Aluminum – Epoxy Coated
Output Gear	ASTM A536 Ductile Iron
Worm Gear	EN8 Carbon Steel
Eccentric Bearing	Aluminum – Hard Anodized
External Fasteners	304 Stainless Steel
Lubricant	Mobil EP1 Grease

How to order

The manual override is a Worcester RB Series declutchable gear override capable of being sandwich-mounted between the Series F39 actuator and valve. The gear override should also include the LV1 NAMUR lockout and vent valve. The LV1 exhausts internal actuator pressure to the atmosphere while blocking supply pressure. The internal porting of the LV1 also prevents possible corrosive atmospheres from entering the actuator during manual operation.



Declutch torque data

To compensate for gear override declutch torque friction, the actuator output torque should be de-rated by 15 in-lbs for the RB0 gear override. This applies to the RBI1039V and RBI1015V gear override kits.

Dimensions

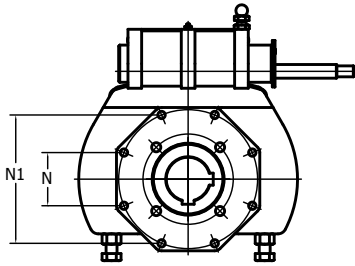

ACTUATOR "42F39 - 50F39"

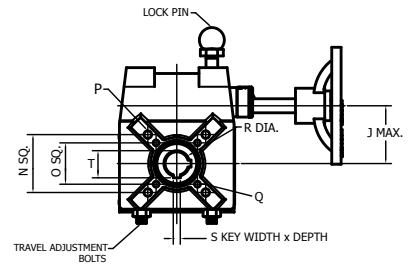
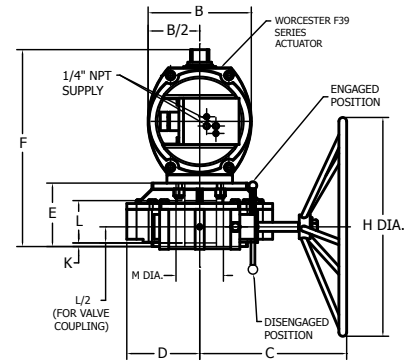
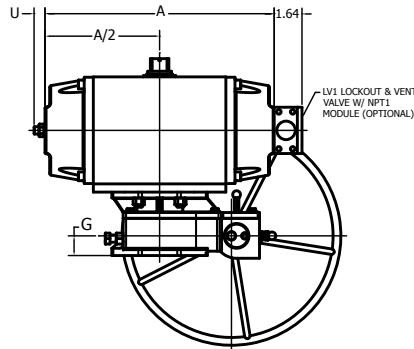

ACTUATOR "10F39 - 40F39"

NOTE:
1. ACTUATOR IS SHOWN IN THE FULL CLOCKWISE POSITION AS VIEWED FROM THE ACCESSORY SIDE.

Actuator	Manual Override	Gear Part No.	A (in)	B (in)	C (in)	D (in)	E (in)	F (in)	G (in)	Handwheel Part No.	H (in)	J (in)	K (in)	L (in)	M (in)
10F39	RBI10F39V	RB0-I	6.11	3.02	5.53	1.93	2.99	7.143	1.00	ARMH100-I	3.94	1.94	0.12	1.38	1.49
10F39	RBI15F39V	RB0-I	7.69	3.70	5.53	1.93	2.68	7.559	1.00	ARMH100-I	3.94	1.94	0.12	1.38	1.49
20F39	RBI20F39V	RB1-I	9.27	4.57	8.84	2.87	3.41	9.122	1.42	ARMH150-I	5.91	2.93	0.63	2.05	1.66
25F39	RBI25F39V	RB1-I	10.67	5.33	8.84	2.87	3.41	10.366	1.42	ARMH150-I	5.91	2.93	0.63	2.05	1.66
30F39	RBI30F39V	RB1-I	12.80	6.10	9.04	2.87	3.41	11.189	1.42	ARMH250-I	9.84	2.93	0.63	2.05	1.66
33F39	RBI33F39V	RB2-I-F12	15.70	8.11	12.01	5.26	4.53	14.134	1.57	ARMH300-I	11.81	5.20	0.28	3.38	2.68
35F39	RBI35F39V	RB2-I-F12	16.69	8.39	12.01	5.26	4.53	14.252	1.57	ARMH300-I	11.81	5.20	0.28	3.38	2.68
40F39	RBI40F39V	RB2-I-F14	20.15	9.64	12.01	5.26	4.78	17.612	1.57	ARMH500-I	19.69	5.20	0.28	3.38	2.68
42F39	RBI42F39V	RB3-I	24.75	11.14	15.87	7.87	7.10	21.510	2.13	ARMH600-I	23.62	7.76	0.39	4.57	5.12
45F39	RBI45F39V	RB3-I	22.67	13.19	15.87	7.87	7.10	23.774	2.13	ARMH600-I	23.62	7.76	0.39	4.57	5.12
50F39	RBI50F39V	RB3-I	24.65	15.26	17.83	7.87	7.10	25.770	2.13	ARMH800-I	31.50	7.76	0.39	4.57	5.12

Actuator	ISO N	N (in)	N1 (in)	ISO O (in)	O (in)	P (in)	Q (in)	R (mm) Max/Min.	S (mm)	T (mm)		U (in)	Approximate Actuator Weight (lb)		Approximate Gear Assembly Weight (lb)
										DA	SR		DA	SR	
10F39	F07	1.949	-	F05	1.392	5/16-18 UNC X 0.47 DEEP	1/4-20 UNC X 0.38 DEEP	20.04/20.00	6 x 6	22.75	+0.20/-0.00	0.39	3	3.5	4.5
15F39	F07	1.949	-	F05	1.392	5/16-18 UNC X 0.47 DEEP	1/4-20 UNC X 0.38 DEEP	20.04/20.00	6 x 6	22.75	+0.20/-0.00	0.43	6	7	4.5
20F39	F10	2.840	-	F07	1.949	3/8-16 UNC X 0.56 DEEP	5/16-18 UNC X 0.47 DEEP	30.03/30.00	8 x 7	33.30	+0.20/-0.00	0.59	10	12	11
25F39	F10	2.840	-	F07	1.949	3/8-16 UNC X 0.56 DEEP	5/16-18 UNC X 0.47 DEEP	30.03/30.00	8 x 7	33.30	+0.20/-0.00	0.83	16	18.5	11
30F39	F10	2.840	-	F07	1.949	3/8-16 UNC X 0.56 DEEP	5/16-18 UNC X 0.47 DEEP	30.03/30.00	8 x 7	33.30	+0.20/-0.00	0.91	24	27	11
33F39	F14	3.898	-	-	-	5/8-11 UNC X 0.63 DEEP	-	45.00/44.96	14 x 9	48.80	+0.20/-0.00	0.91	50	57	25
35F39	F14	3.898	-	-	-	5/8-11 UNC X 0.63 DEEP	-	45.00/44.96	14 x 9 mm	48.80	+0.20/-0.00	1.18	57	66	25
40F39	F14	3.898	-	-	-	5/8-11 UNC X 0.63 DEEP	-	45.00/44.96	14 x 9	48.80	+0.20/-0.00	1.06	96	107	25
42F39	F25	3.827	9.239	F16	4.594	5/8-11 UNC X 0.67 DEEP*	3/4-10 UNC X 0.87 DEEP	80.00/79.96	22 x 14	85.90	+0.20/-0.00	1.18	158	177	120
45F39	F25	3.827	9.239	F16	4.594	5/8-11 UNC X 0.67 DEEP*	3/4-10 UNC X 0.87 DEEP	80.00/79.96	22 x 14	85.90	+0.20/-0.00	1.10	213	253	120
50F39	F25	3.827	9.239	F16	4.594	5/8-11 UNC X 0.67 DEEP*	3/4-10 UNC X 0.87 DEEP	80.00/79.96	22 x 14	85.90	+0.20/-0.00	1.38	304	354	120

*These units have 8 mounting holes instead of 4.