

# **SIHI® LPH 85/95**

## **Two-Stage Liquid Ring Vacuum Pumps**

Models 85340, 85353, 95354, 95367



## Proven liquid ring performance

Many pumps become unreliable when liquid or vapor are present in a gas element. The liquid ring technology used in SIHI LPH 85/95 vacuum pumps is a proven economical alternative. By creating a “ring” of service liquid around the rotating element, liquid ring vacuum pumps efficiently handle gases in a wide range of industrial processes. Liquids and condensed vapors effectively are separated out of the process and can be discharged, recirculated or recovered.

### Benefits

- Near isothermal compression
- Oil-free; no internal lubrication required
- Handles almost all gases and vapors
- Tolerant to some liquid carryover
- Low maintenance and safe operation
- Low noise and almost vibration-free
- Available in a wide range of materials
- No metallic contact of the rotating parts

### Applications

SIHI LPH 85/95 two-stage vacuum pumps are engineered to operate in applications where vacuums of 33 to 900 mbar (24.7 to 675 torr) must be created. A broad selection of alloys is available for corrosive applications.

### Principle industries

- Chemical
- Pharmaceutical
- Food and beverage
- Medical
- Power generation
- Oil and gas
- General industry

### Key vacuum applications

- Drying
- Distillation
- Filtration
- Sterilization
- Deaeration and gasification
- Forming and extrusion
- Vacuum chucking
- Scrubbing and vapor recovery
- Packaging and bottling
- Poultry processing
- Batch reactors

### General technical data

Parameter	Unit(s)	Model					
		LPH 85340		LPH 85353	LPH 95354		LPH 95367
Speeds	rpm	700	735 <sup>(1)</sup>	880	465	585 <sup>(1)</sup>	700
Max. compression over pressure	bar (psi)	1.5 (21.8)					
Max. admissible pressure difference (per speed)	bar (psi)	1.5 (21.8)	1.5 (21.8)	1.2 (17.4) <sup>(2)</sup>	1.5 (21.8)	1.5 (21.8)	1.2 (17.4) <sup>(2)</sup>
Hydraulic test (over pressure)	bar (psi)	3 (43.5)					
Moment of inertia of the rotating pump parts and the water filling	kg • m <sup>2</sup> (lb • ft <sup>2</sup> )	8.5 (202)	10 (237)		28 (664)		32 (759)
Sound pressure level at 80 mbar (60 torr) suction pressure (per speed)	dB(A)	80	80	82	87	88	90
Min. pulley diameter permissible in case of V-belt drive	mm (in)	315 (12.4)		450 (17.7)		710 (30.0)	
Max. gas temperature	Dry	160 (320)					
	Saturated	80 (176)					
Service liquid	Max. temperature	60 (140)					
	Max. viscosity	90 (0.001)					
	Max. density	1,200 (12)					
	Volume to shaft	75 (19.8)	91 (24.0)		228 (60.2)		250 (60.0)
Max. flow resistance of the heat exchanger	bar (psi)	0.2 (2.9)					

(1) Normal speed, (2) 1.5 bar (21.8 psi) in case of belt drive

Sectional drawing and material design —  
LPH 85340, LPH 85353

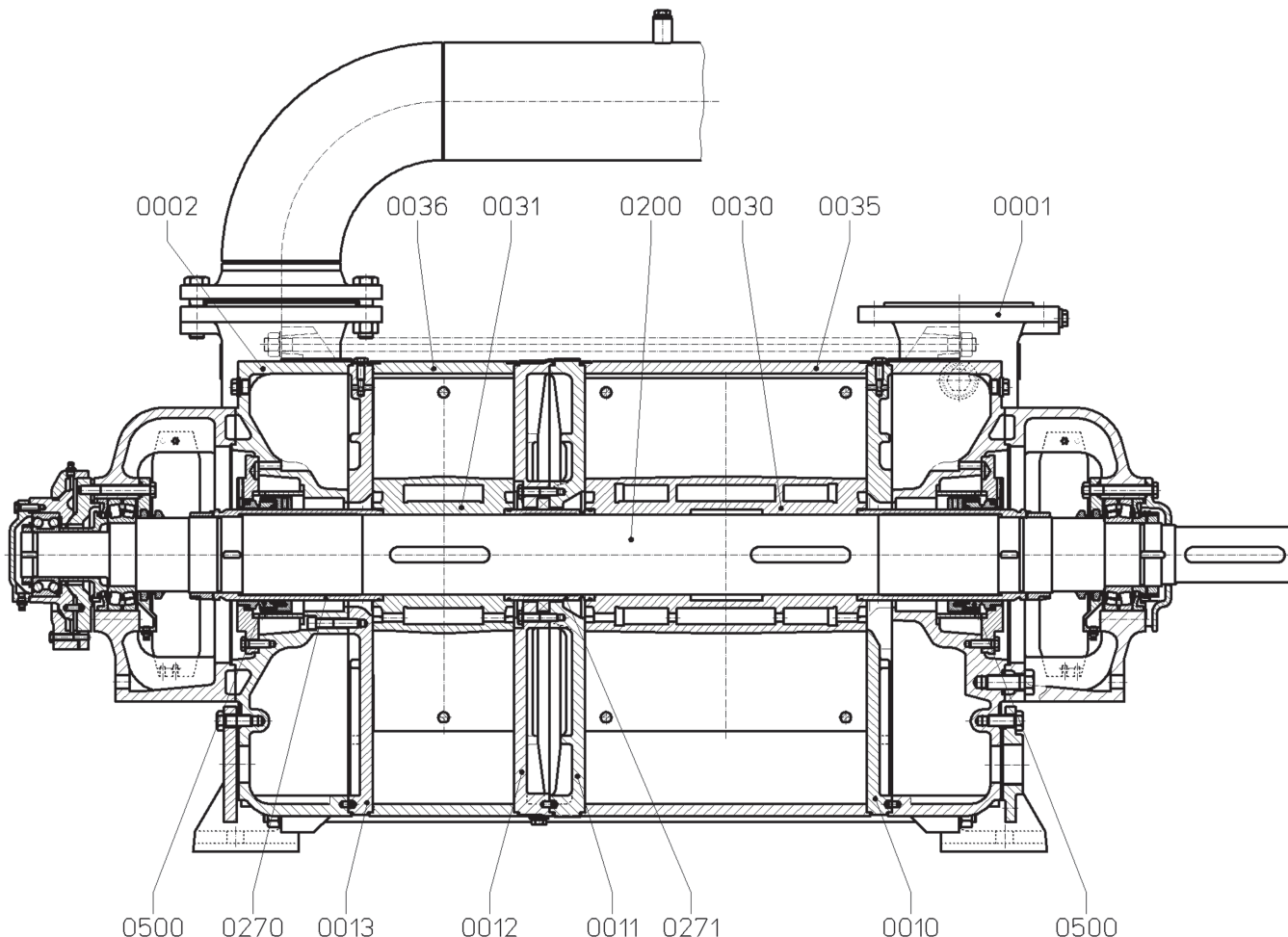

Item Number	Description	Materials of Construction	
		02 - Cast Iron/Carbon Steel	42 - Stainless Steel
0001, 0002	Casing	Cast iron - 0.6025	Stainless steel - 1.4408
0010, 0011	Guide disk	Cast iron - 0.6025	Stainless steel - 1.4408
0012, 0013			
0030, 0031	Vane wheel impeller	Steel - 1.0619	Stainless steel - 1.4408
0035, 0036	Central body	Carbon steel - Q235B	Stainless steel - AISI 316L
200	Shaft	Carbon steel - 55 steel	Carbon steel - 55 steel
0270, 0271	Shaft sleeve	Stainless steel - AISI 316L	Stainless steel - AISI 316L
0500	Mechanical seal	CrMo-steel, carbon and Viton® (Code: SBVGG)	CrMo-steel, carbon and Viton (Code: SBVGG)

© Viton is a registered trademark of the DuPont Company.

Sectional drawing and material design –  
LPH 95354, LPH 95367

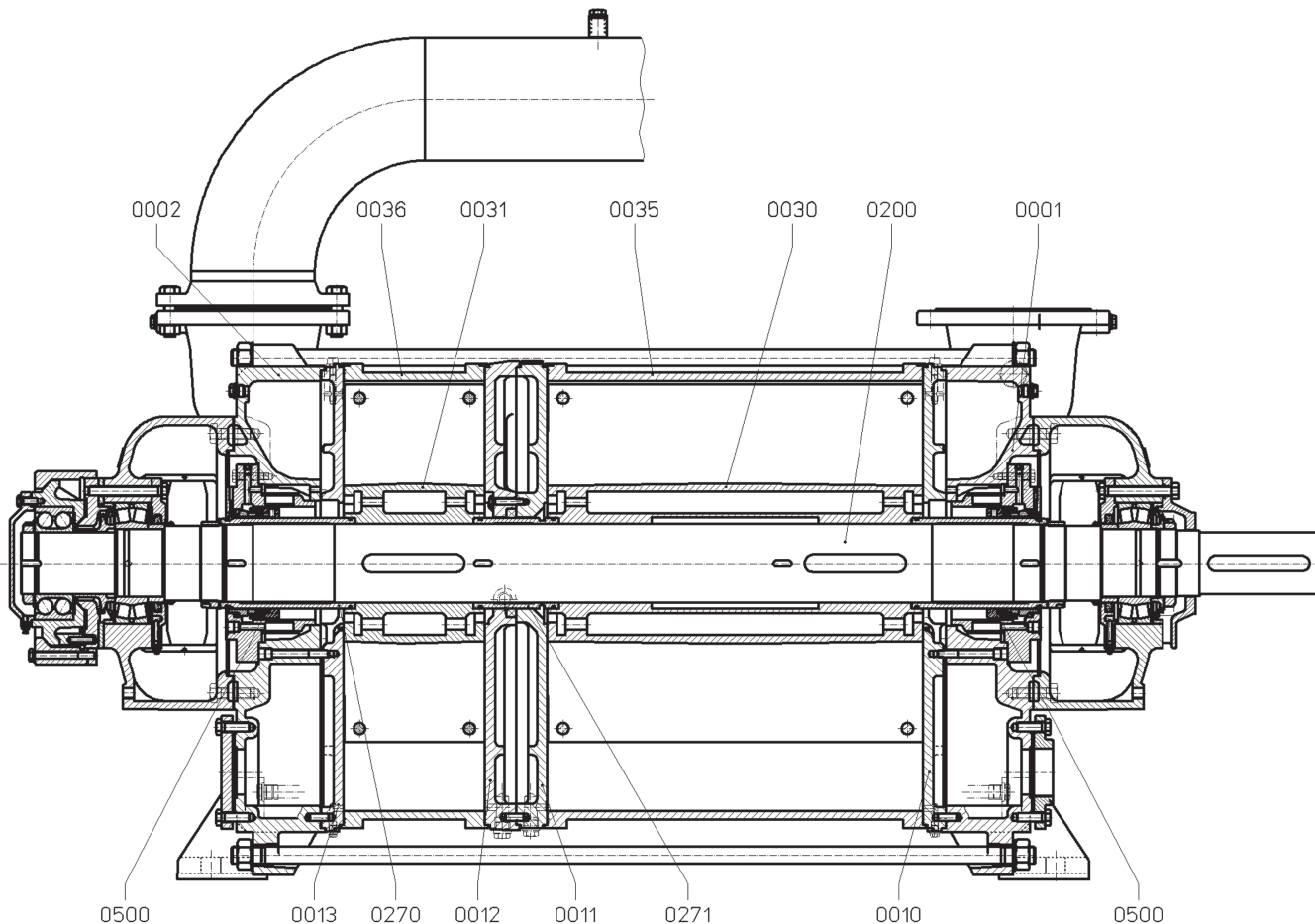

Item Number	Description	Materials of Construction	
		02 - Cast Iron/Carbon Steel	42 - Stainless Steel
0001, 0002	Casing	Cast iron - 0.6025	Stainless steel - 1.4408
0010, 0011	Guide disk	Cast iron - 0.6025	Stainless steel - 1.4408
0012, 0013			
0030, 0031	Vane wheel impeller	Steel - 1.0619	Stainless steel - 1.4408
0035, 0036	Central body	Carbon steel - Q235B	Stainless steel - AISI 316L
200	Shaft	Carbon steel - 55 steel	Carbon steel - 55 steel
0270, 0271	Shaft sleeve	Stainless steel - AISI 316L	Stainless steel - AISI 316L
0500	Mechanical seal	CrMo-steel, carbon and Viton (Code: SBVGG)	CrMo-steel, carbon and Viton (Code: SBVGG)

Suction volume flow and power absorption

LPH 85340

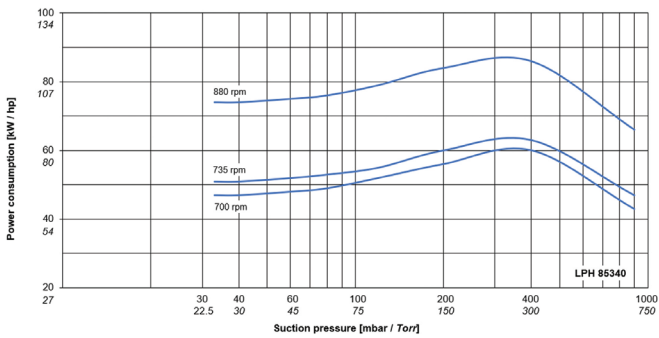
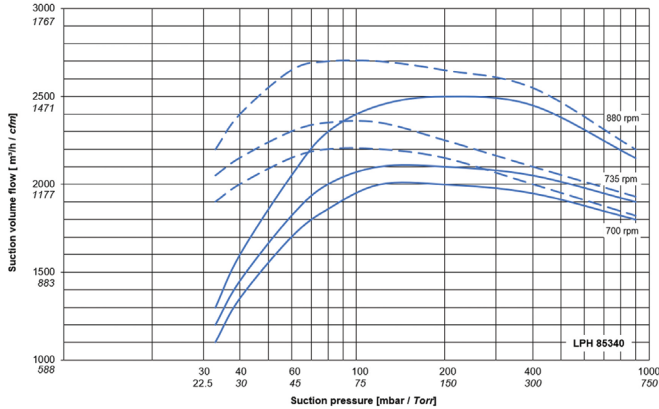

LPH 85353

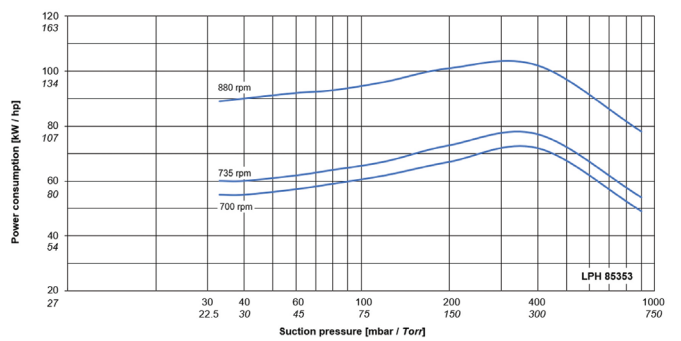
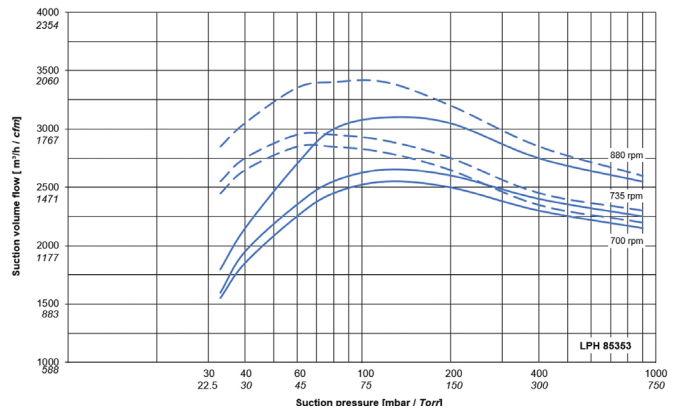

The operating data are applicable under the following conditions:

- Pumping medium:
  - dry air: 20°C (68°F) ———
  - water vapor saturated air: 20°C (68°F) - - - -
- Service liquid:
  - water: 15°C (59°F)
- Compression pressure: 1,013 mbar (760 torr)
- The suction volume flow is applied to the suction pressure.
- Tolerance of the operating data is 10%.
- Max. fresh water needed with lowest suction pressure

Suction volume flow and power absorption

LPH 95354

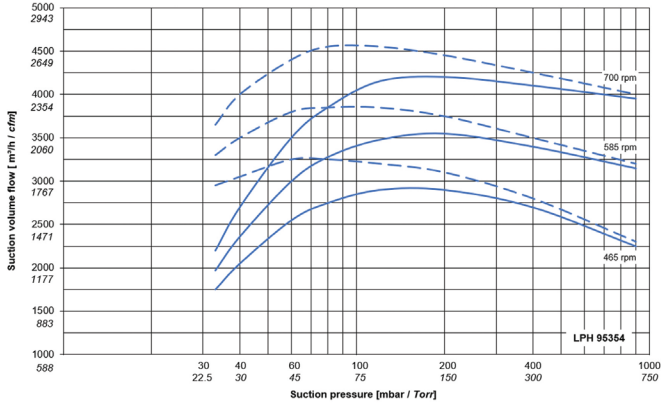

LPH 95367

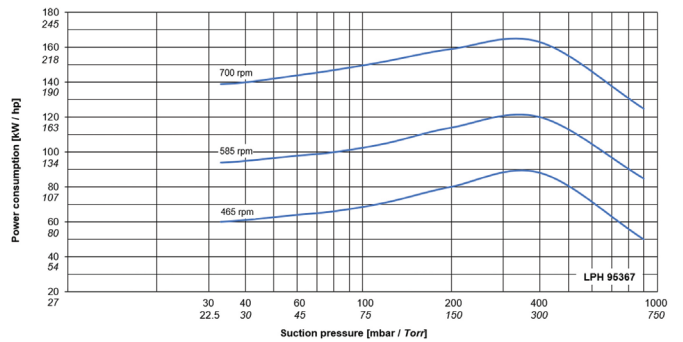
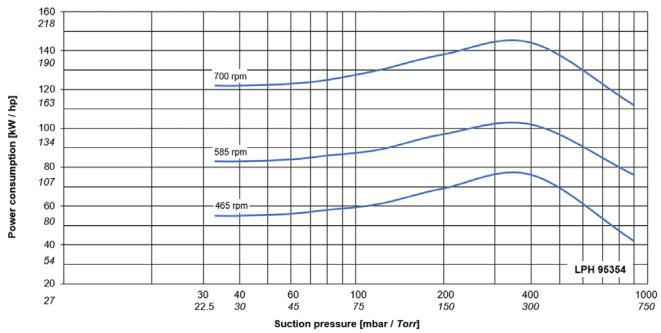
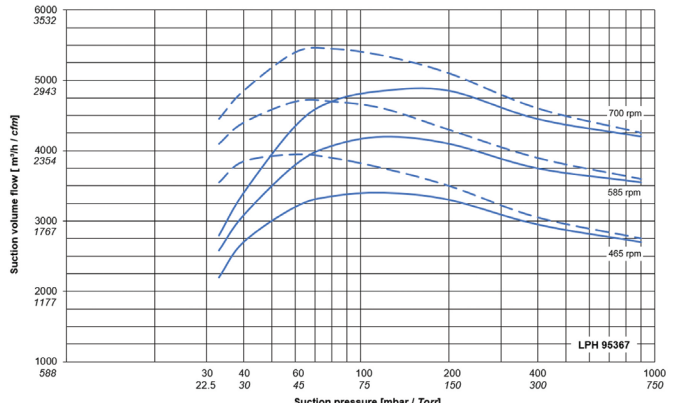

The operating data are applicable under the following conditions:

- Pumping medium:
  - dry air: 20°C (68°F) ———
  - water vapor saturated air: 20°C (68°F) - - - -
- Service liquid:
  - water: 15°C (59°F)
- Compression pressure: 1,013 mbar (760 torr)
- The suction volume flow is applied to the suction pressure.
- Tolerance of the operating data is 10%.
- Max. fresh water needed with lowest suction pressure

Dimension table – LPH 85340, LPH 85353

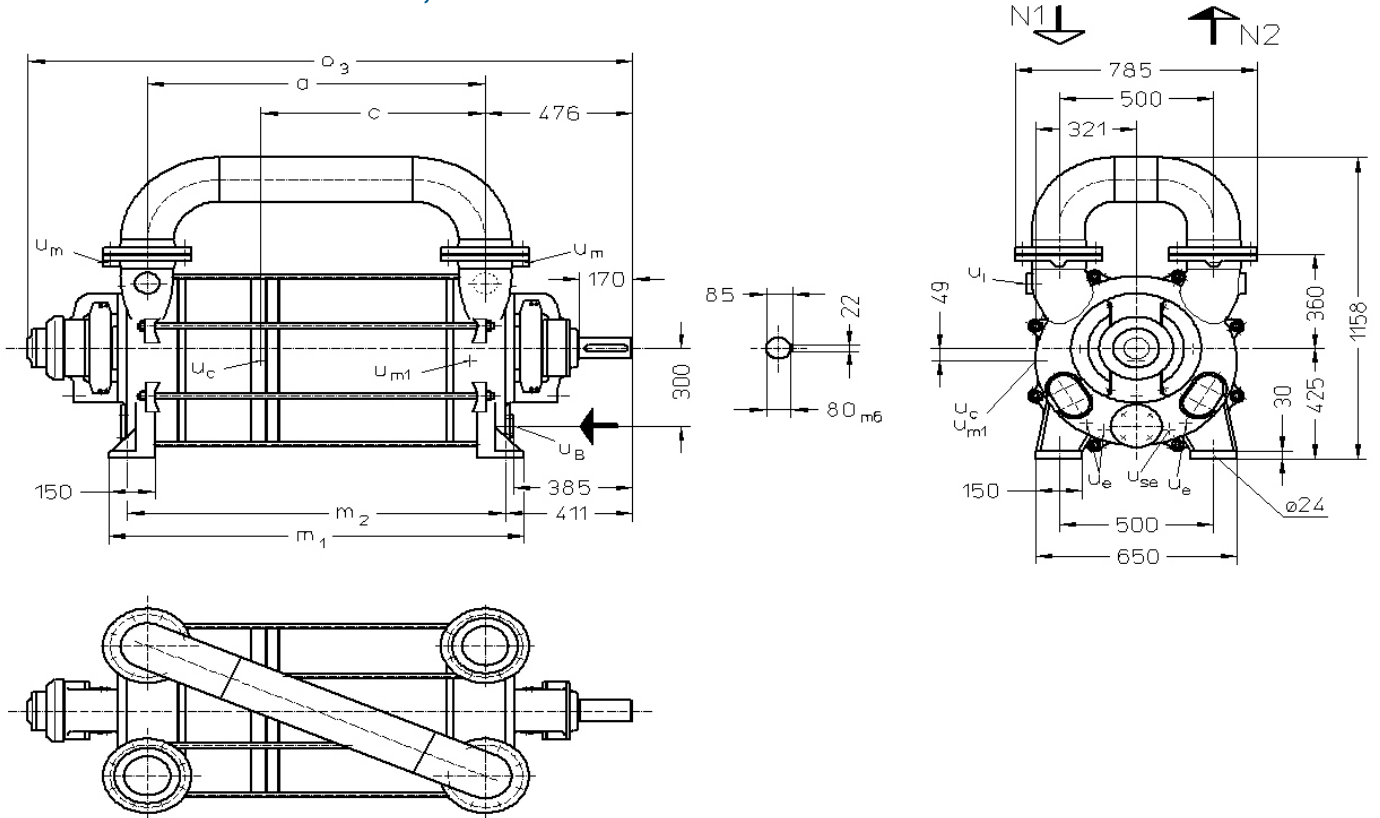

N 1 = gas inlet DN 150

N 2 = gas outlet DN 150

u<sub>B</sub> = connection for service liquid G 2

u<sub>c</sub> = connection for protection against cavitation G ½

u<sub>e</sub> = drain connection G ½

u<sub>i</sub> = connection for vent cock G 1½

u<sub>m</sub> = connection for pressure gauge G ½

u<sub>m1</sub> = connection for drain valve G ½

u<sub>se</sub> = connection for dirt drain G ½

Model	Dimensions, mm (in)					Approx. Weight, kg (lb)	
	a	c	m <sub>1</sub>	m <sub>2</sub>	o <sub>3</sub>	02 Cast Iron/Carbon Steel	42 Stainless Steel
LPH 85340 BN	961 (37.83)	596 (23.46)	1,211 (47.68)	1,091 (42.95)	1,823 (71.77)	1,180 (2,601)	1,260 (2,778)
LPH 85353 BN	1,091 (42.95)	726 (28.58)	1,341 (52.79)	1,221 (48.07)	1,953 (76.89)	1,285 (2,833)	1,375 (3,031)

Flange Connections to DIN 2501 PN 10	
DN in mm (in)	150 (5.90)
k in mm (in)	240 (9.45)
D in mm (in)	285 (11.22)
number x d <sub>2</sub>	8 x 23 (0.91)

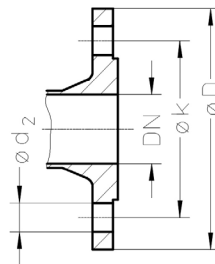

**SIHI LPH 85/95 Two-Stage Liquid Ring Vacuum Pumps**

**Dimension table – LPH 95354, LPH 95367**

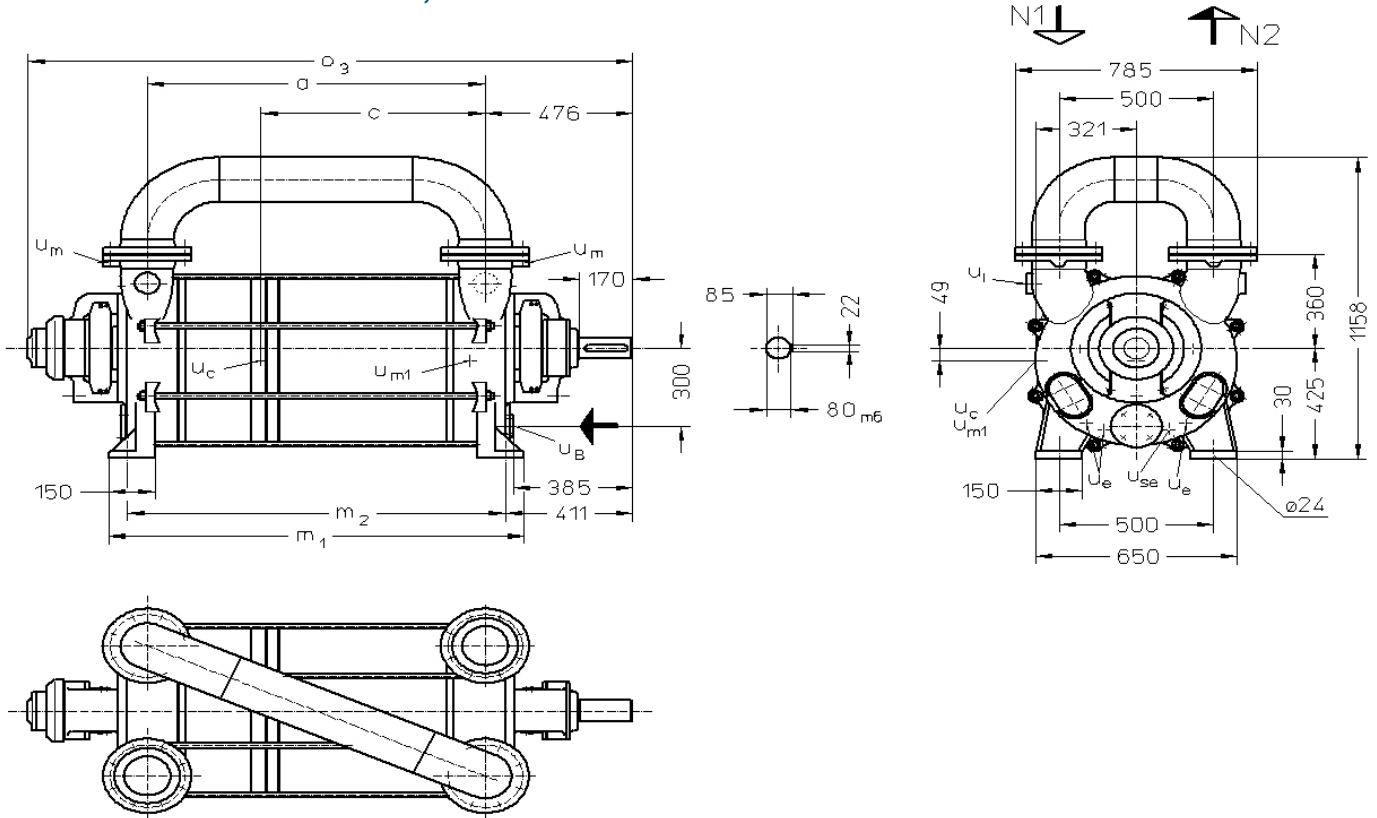

N 1 = gas inlet DN 200

N 2 = gas outlet DN 200

U<sub>B</sub> = connection for service liquid G 3

U<sub>c</sub> = connection for protection against cavitation G ½

U<sub>e</sub> = drain connection G ¾

u<sub>i</sub> = connection for vent cock G 1½

U<sub>m</sub> = connection for pressure gauge G ½

U<sub>m1</sub> = connection for drain valve G ¾

U<sub>se</sub> = connection for dirt drain G ¾

Model	Dimensions, mm (in)					Approx. Weight, kg (lb)	
	a	c	m <sub>1</sub>	m <sub>2</sub>	o <sub>3</sub>	02 Cast Iron/Carbon Steel	42 Stainless Steel
LPH 95354 BN	1,219 (50.83)	776 (30.55)	1,479 (58.23)	1,371 (53.98)	2,194 (86.38)	2,300 (5,071)	2,500 (5,512)
LPH 95367 BN	1,344 (52.91)	901 (35.47)	1,604 (63.15)	1,496 (58.90)	2,319 (91.30)	2,500 (5,512)	2,700 (5,953)

Flange Connections to DIN 2501 PN 10	
DN in mm (in)	200 (7.87)
k in mm (in)	295 (11.61)
D in mm (in)	340 (13.49)
number x d <sub>2</sub> in mm (in)	8 x 23 (0.91)

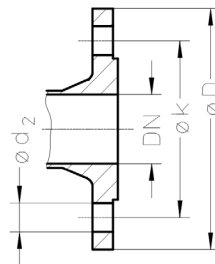



**Arrangement drawing – LPH 85340, LPH 85353 with upright liquid separator**

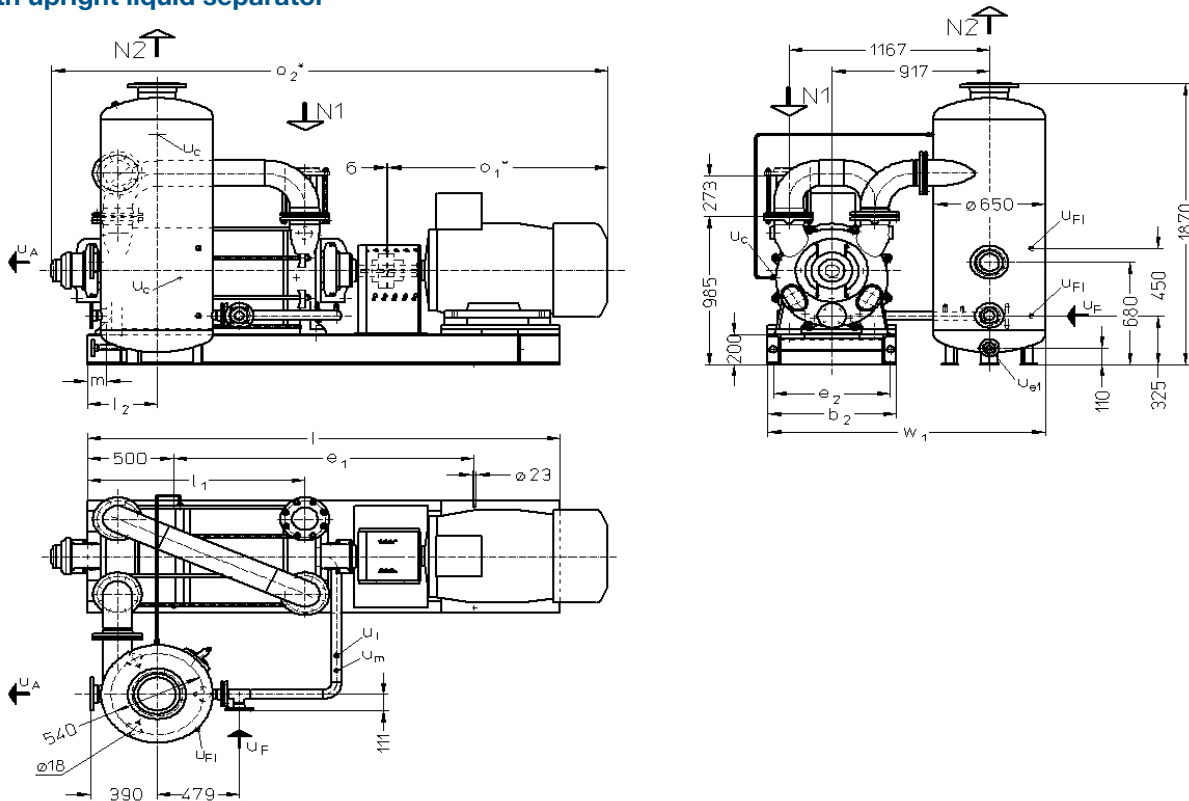

N 1 = gas inlet DN 150

N 2 = gas outlet DN 200

U<sub>A</sub> = connection for liquid drain DN 100

U<sub>C</sub> = connection for protection against cavitation G 3/8

U<sub>e1</sub> = drain connection DN 25

U<sub>F</sub> = connection for fresh liquid DN 50

U<sub>FI</sub> = connection for liquid level indicator G 1/2

U<sub>m</sub> = connection for pressure gauge G 1/4

U<sub>t</sub> = connection for thermometer G 1/2

Model	E-Motor 50 Hz kW (hp)			Dimensions, mm (in)										Approx. Weight, kg (lb)	
	Size	IP 55	EEx e II T3	b <sub>2</sub>	e <sub>1</sub>	e <sub>2</sub>	l	l <sub>1</sub>	l <sub>2</sub>	m	o <sub>1</sub> *	o <sub>2</sub> *	w <sub>1</sub>	With IP 55 Motor	
LPH 85340	315M	75 (100)	-	730	1,550	660	2,550	1,116	385	90	1,140 (44.88)	2,970 (116.93)	1,607 (63.27)	2,412 (5,318)	
	315M	-	68 (91)	(28.74)	(61.02)	(25.98)	(88.58)	(43.94)	(15.16)	(3.54)	1,251 (49.25)	3,080 (121.26)		-	
LPH 85353	315L	90 (120)	-	750 (29.53)	1,750 (68.90)	680 (26.77)	2,750 (108.23)	1,266 (49.84)	405 (15.94)	110 (4.33)	1,280 (50.39)	3,240 (127.56)	1,617 (63.66)	2,602 (5,736)	
	315L	-	80 (107)								1,371 (53.98)	3,330 (131.10)		-	
	355M	-	95 (127)								1,440 (56.69)	3,400 (133.86)		-	

Flange Connections to DIN 2501 PN 10						
DN in mm (in)	25 (0.98)	50 (1.97)	100 (3.94)	150 (5.91)	200 (7.87)	
k in mm (in)	85 (3.35)	125 (4.92)	180 (7.09)	240 (9.45)	295 (11.61)	
D in mm (in)	115 (4.53)	165 (6.50)	220 (8.66)	285 (11.22)	340 (13.39)	
number x d <sub>2</sub> in mm (in)	4 x 14 (0.55)	4 x 18 (0.71)	8 x 18 (0.71)	8 x 22 (0.87)	8 x 22 (0.87)	

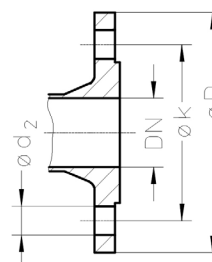

\* Dimensions depend on the motor make.

# SIHI LPH 85/95 Two-Stage Liquid Ring Vacuum Pumps

## Fresh water requirements

Dependent on suction pressure, speed, mode of operation and difference in temperature

Suction Pressure [mbar]		Suction Pressure = 33 mbar (24.7 torr)				Suction Pressure = 120 mbar (90 torr)				
Model	speed [rpm]	KB - Combined Liquid Service, m <sup>3</sup> /h (gpm)			FB - Fresh Liquid Service Water, m <sup>3</sup> /h (gpm)	KB - Combined Liquid Service, m <sup>3</sup> /h (gpm)				FB - Fresh Liquid Service Water, m <sup>3</sup> /h (gpm)
		$\Delta T$ warmer than FB, °C (°F)				$\Delta T$ warmer than FB, °C (°F)				
		10 (18)	5 (9)	2 (3.6)		20 (36)	10 (18)	5 (9)	2 (3.6)	
LPH 85340	700	3.0 (13.2)	4.7 (20.7)	7.1 (31.3)	11 (48.4)	1.8 (7.9)	3.1 (13.6)	4.7 (20.7)	6.9 (30.4)	10 (44.0)
	735	3.1 (13.6)	4.9 (21.6)	7.3 (32.1)		1.9 (8.4)	3.2 (14.1)	4.9 (21.6)	7.0 (30.8)	
	880	4.0 (17.6)	5.9 (26.0)	8.2 (36.1)		2.5 (11.0)	4.0 (17.6)	5.8 (25.5)	7.7 (33.9)	
LPH 85353	700	3.5 (15.4)	5.6 (24.6)	8.8 (38.7)	14 (61.6)	2.2 (9.7)	3.8 (16.7)	5.9 (26.0)	8.7 (38.3)	13 (57.2)
	735	3.8 (16.7)	5.9 (26.0)	9.1 (40.1)		2.4 (10.6)	4.0 (17.6)	6.1 (26.9)	9.0 (39.6)	
	880	4.9 (21.6)	7.3 (32.1)	10.2 (44.9)		3.1 (13.6)	5.0 (22.0)	7.3 (32.1)	9.9 (43.6)	
LPH 95354	465	3.8 (16.7)	6.3 (27.7)	10.5 (46.2)	19 (83.6)	2.3 (10.1)	4.1 (18.1)	6.6 (29.1)	10.7 (47.1)	18 (79.3)
	585	5.2 (22.9)	8.1 (35.7)	12.4 (54.6)		3.2 (14.1)	5.4 (23.8)	8.3 (36.5)	12.2 (53.7)	
	700	6.8 (29.9)	10.0 (44.0)	13.9 (61.2)		4.3 (18.9)	6.9 (30.4)	10.0 (44.0)	13.6 (59.9)	
LPH 95367	465	4.1 (18.1)	6.9 (30.4)	11.6 (51.1)	21 (92.4)	2.6 (11.4)	4.6 (20.3)	7.4 (32.6)	11.7 (51.5)	19 (83.6)
	585	5.8 (25.5)	9.1 (40.0)	13.8 (60.8)		3.6 (15.9)	6.1 (26.9)	9.3 (40.9)	13.4 (59.0)	
	700	7.6 (33.5)	11.2 (49.3)	15.5 (68.2)		4.9 (21.6)	7.7 (33.9)	11.0 (48.4)	14.7 (64.7)	

Suction Pressure [mbar]		Suction Pressure = 200 mbar (150 torr)				Suction Pressure = 400 mbar (300 torr)					
Model	speed [rpm]	KB - Combined Liquid Service, m <sup>3</sup> /h (gpm)			FB - Fresh Liquid Service Water, m <sup>3</sup> /h (gpm)	KB - Combined Liquid Service, m <sup>3</sup> /h (gpm)				FB - Fresh Liquid Service Water, m <sup>3</sup> /h (gpm)	
		$\Delta T$ warmer than FB, °C (°F)				$\Delta T$ warmer than FB, °C (°F)					
		20 (36)	10 (18)	5 (9)		2 (3.6)	20 (36)	10 (18)	5 (9)		2 (3.6)
LPH 85340	700	1.9 (8.4)	3.1 (13.6)	4.5 (19.8)	6.3 (27.7)	8.5 (37.4)	1.7 (7.5)	2.5 (11.0)	3.4 (15.0)	4.2 (18.5)	5 (22.0)
	735	2.0 (8.8)	3.2 (14.1)	4.7 (20.7)	6.4 (28.2)		1.8 (7.9)	2.6 (11.4)	3.4 (15.0)	4.2 (18.5)	
	880	2.5 (11.0)	3.9 (17.2)	5.3 (23.3)	6.9 (30.4)		2.1 (9.2)	3.0 (13.2)	3.7 (16.3)	4.4 (19.4)	
LPH 85353	700	2.3 (10.1)	3.8 (16.7)	5.6 (24.6)	8.0 (35.2)	11 (48.4)	2.1 (9.2)	3.3 (14.5)	4.5 (19.8)	5.7 (25.1)	7 (30.8)
	735	2.4 (10.6)	4.0 (17.6)	5.9 (26.0)	8.1 (35.7)		2.2 (9.7)	3.4 (15.0)	4.6 (20.2)	5.8 (25.5)	
	880	3.1 (13.6)	4.9 (21.6)	6.7 (29.5)	8.8 (38.7)		2.7 (11.9)	3.9 (17.2)	5.0 (22.0)	6.0 (26.4)	
LPH 95354	465	2.5 (11.0)	4.3 (18.9)	6.8 (29.9)	10.4 (45.8)	16 (70.4)	2.5 (11.0)	4.1 (18.1)	6.0 (26.4)	8.2 (36.1)	11 (48.4)
	585	3.3 (14.5)	5.5 (24.2)	8.2 (36.1)	11.6 (51.1)		3.1 (13.6)	4.9 (21.6)	6.8 (29.9)	8.8 (38.7)	
	700	4.3 (18.9)	6.8 (29.9)	9.6 (42.3)	12.6 (55.5)		4.0 (17.6)	5.8 (25.5)	7.6 (33.5)	9.3 (41.0)	
LPH 95367	465	2.9 (12.8)	4.9 (21.6)	7.6 (33.5)	11.4 (50.2)	17 (74.8)	2.8 (12.3)	4.5 (19.8)	6.4 (28.2)	8.5 (37.4)	11 (48.4)
	585	3.8 (16.7)	6.2 (27.3)	9.1 (40.1)	12.6 (55.5)		3.5 (15.4)	5.3 (23.3)	7.2 (31.7)	9.1 (40.1)	
	700	4.9 (21.6)	7.6 (33.5)	10.5 (46.2)	13.6 (59.9)		4.3 (18.9)	6.2 (27.3)	7.9 (34.8)	9.5 (41.8)	

FB = fresh liquid service

KB = combined liquid service water 20°C (68°F), 10°C (50°F), 5°C (41°F), 2°C (36°F) warmer than the fresh water

**Example for ordering:**

Data regarding the pump size									
Series	Size	Bearing + Direction of Rotation		Shaft Sealing		Material Design		Casing Seal	
		B•	Two grease-lubricated, antifriction bearing	DAC	Mechanical seal with built-in flushing, Viton O-rings	02	Main parts cast iron without non-ferrous metal	0	Liquid seal
•N	One shaft end, clockwise rotating	42	Main parts stainless steel						
LPH	85340	BN		DAC		02, 42		0	
	85353								
	95354			DAC					
	95367								

**Example for ordering:**

The pump size LPH 85340 BN 041 02 0

is the complete order number: **LPH• 85340 BN DAC 02 0**

On delivery, the point (•) in the fourth place of the type code is replaced by a letter in the factory.



## Accessories

Accessories	Material Designation	Type		Weight, kg (lb)		Part Number					
		LPH 85340	LPH 85353	LPH 85340	LPH 85353	LPH 85340	LPH 85353				
<b>Upright liquid separator</b>	Galvanized steel	XBp 5013		148 (326)		35000585					
	Stainless steel					35000586					
<i>Service liquid line</i>	Steel					35003189	35007072				
	Stainless steel					35003190	35003191				
<i>Discharge line (bend)</i>	Steel					35003237					
	Stainless steel					35003238					
<b>Flowserve SIHI-ball type non-return valve</b>	Cast iron					XCk 150	XCk 28	35 (77)		20072800	
	Stainless steel									20006987	
<b>Base frame</b>	Steel	-	-	417 (919)	423 (933)	35012206	35012207				

Accessories	Material Designation	Type		Weight, kg (lb)		Part Number	
		LPH 95354	LPH 95367	LPH 95354	LPH 95367	LPH 95354	LPH 95367
<b>Upright liquid separator</b>	Galvanized steel	XBp 10112		205 (452)		35000593	
	Stainless steel					20000612	
<i>Service liquid line</i>	Steel					20027252	20027253
	Stainless steel					35003228	20027254
<i>Discharge line (bend)</i>	Steel					20027265	
	Stainless steel					35003238	

Any changes in the interest of technical development are reserved.

Flowserve Corporation  
 5215 North O'Connor Blvd.  
 Suite 2300  
 Irving, Texas 75039-5421 USA  
 Telephone: +1 937 890 5839

Flowserve Corporation has established industry leadership in the design and manufacture of its products. When properly selected, this Flowserve product is designed to perform its intended function safely during its useful life. However, the purchaser or user of Flowserve products should be aware that Flowserve products might be used in numerous applications under a wide variety of industrial service conditions. Although Flowserve can provide general guidelines, it cannot provide specific data and warnings for all possible applications. The purchaser/user must therefore assume the ultimate responsibility for the proper sizing and selection, installation, operation, and maintenance of Flowserve products. The purchaser/user should read and understand the Installation Instructions included with the product, and train its employees and contractors in the safe use of Flowserve products in connection with the specific application.

While the information and specifications contained in this literature are believed to be accurate, they are supplied for informative purposes only and should not be considered certified or as a guarantee of satisfactory results by reliance thereon. Nothing contained herein is to be construed as a warranty or guarantee, express or implied, regarding any matter with respect to this product. Because Flowserve is continually improving and upgrading its product design, the specifications, dimensions and information contained herein are subject to change without notice. Should any question arise concerning these provisions, the purchaser/user should contact Flowserve Corporation at any one of its worldwide operations or offices.

©2020 Flowserve Corporation. All rights reserved. This document contains registered and unregistered trademarks of Flowserve Corporation. Other company, product, or service names may be trademarks or service marks of their respective companies.

PUTB000128-01 (EN/A4) April 2020