

Dimensions (inches)

Pump Model	A	B	C	D
25003	10.88	6.44		13.72
25007	12.84	8.40		15.68

For connection sizes/ratings and motor sizes refer to engineering data table on reverse.

For baseplate mounting, please obtain factory certified dimensions.

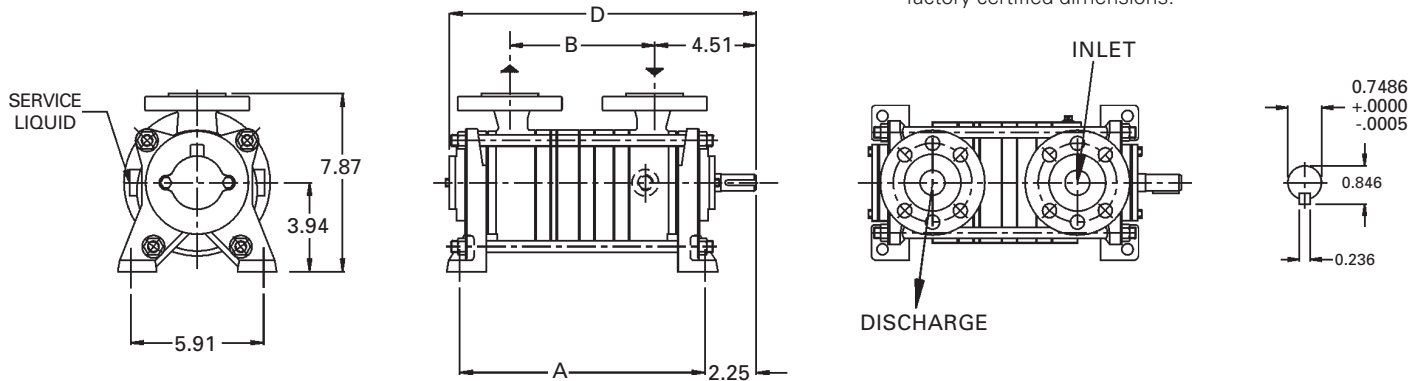

Capacity Table

Pump Model - LPH 25003												
Speed (RPM)	20" Hg. 252 Torr		22.5" Hg. 188 Torr		25" Hg. 125 Torr		27.5" Hg. 61.5 Torr		28" Hg. 49 Torr		28.7" Hg. 31 Torr	
	acfm	HP	acfm	HP	acfm	HP	acfm	HP	acfm	HP	acfm	HP
3500	14.9	1.8	14.9	1.8	14.5	1.8	11.5	1.8	11.0	1.8	7.0	1.8
2900	12.0	1.1	12.0	1.1	12.0	1.1	10.5	1.1	9.5	1.1	6.5	1.1

Pump Model - LPH 25007												
3500	31.0	2.6	31.0	2.6	31.0	2.4	26.5	2.4	23.0	2.4	12.0	2.4
2900	24.5	1.8	25.0	1.8	26.0	1.8	21.5	1.8	19.0	1.8	11.0	1.8

This data represents average values for pumps in standard materials. Capacity in actual cubic feet per minute at 68°F (20°C) using 60°F (16°C) water as a service liquid. Vacuum in inches Hg. Barometric pressure at sea level 29.92" Hg. abs. (760 Torr).

All performance data per HEI standards; subject to SIHI standard tolerances.

ENGINEERING DATA

SERVICE LIQUID RATES (USGPM)

PUMP MODEL	25003	25007
Gas Conn. Size/Rating (U)	1¼"/150RF	1¼"/150RF
Service Liq. Line Size/Rating (U <sub>B</sub> )	¾"/NPT	¾"/NPT
Cont. Drain Size/Rating (U <sub>se</sub> )	N/A	N/A
Motor (@ 3500 rpm) HP	2.0	3.0
Bare Pump Wt. (lb)	55	60
4 Direct Dr. Basemount (lb)	131	198
5 Min. V-Belt Sheave Dia.	3.15"	3.15"
Separator Model - XBA	0340	0340
Separator Size - Recirc. (Gal.)	10	10
1/2 Norm. Max. Gas Temp. (°F)	248	248
2 Max. Service Liq. Temp. (°F)	212	212
3 Sound Level @ 27.5" Hg.V (dBA)	67	67
Moment of Inertia Wr <sup>2</sup> (lb. ft <sup>2</sup> )	0.095	0.154
Casing Max. Working Pressure (psi)	30	30
Pneumatic Test Pressure (psig)	15	15

PUMP MODEL - LPH 25003															
Pump Speed	20" Hg. 252 Torr			25" Hg. 125 Torr			27.5" Hg. 61.5 Torr			28" Hg. 49 Torr			28.7" Hg. 31 Torr		
	A	B	C	A	B	C	A	B	C	A	B	C	A	B	C
3500		0.5	0.3		0.5	0.3		0.6	0.3		0.6	0.3		0.6	0.4
2900	1.2	0.4	0.2	1.35	0.4	0.2	1.45	0.4	0.2	1.45	0.4	0.2	1.5	0.4	0.2

PUMP MODEL - LPH 25007															
Pump Speed	20" Hg. 252 Torr			25" Hg. 125 Torr			27.5" Hg. 61.5 Torr			28" Hg. 49 Torr			28.7" Hg. 31 Torr		
	A	B	C	A	B	C	A	B	C	A	B	C	A	B	C
3500		0.6	0.4		0.6	0.4		0.7	0.4		0.7	0.4		0.7	0.4
2900	1.2	0.5	0.3	1.35	0.5	0.3	1.45	0.6	0.3	1.45	0.6	0.3	1.5	0.6	0.4

Column 'A' is the flow in USGPM required - once through.  
 Column 'B' is the make-up flow required when make-up water is 5°C (9°F) cooler than service water.  
 Column 'C' is the make-up flow when make-up water is 10°C (18°F) cooler than service water.

**Note:** The service liquid supply pressure may vary with pump speed and vacuum level. Please consult factory engineering department for additional information.

1. Max. gas temperature with saturated gases.
2. Higher temperatures possible on request.
3. At 3 ft., 3500 RPM w/o motor (not certified).
4. Basemount includes pump, motor, coupling, guard and base.
5. Special pump bearings required for V-Belt applications.

SECTIONAL

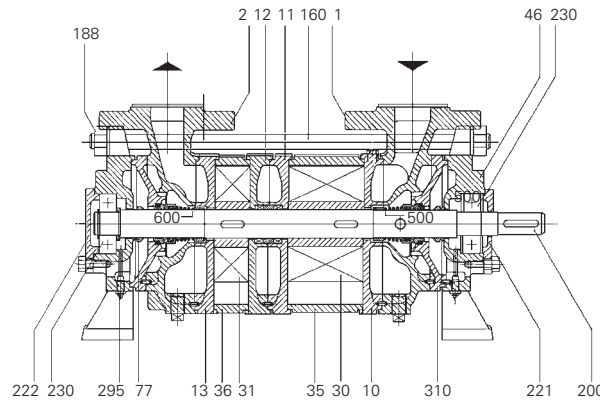

Standard rotation 'AB' (clockwise) viewed from driven end. 'AL' (counter-clockwise) upon request.

PARTS LIST

- |                    |                  |                        |                       |                      |
|--------------------|------------------|------------------------|-----------------------|----------------------|
| 1. Suction Cover   | 13. Intermediate | 46. Bearing Flange     | 221. Bearing Cover    | 310. Seal Housing    |
| 2. Discharge Cover | 30. Impeller     | 77. Splash Ring        | 222. Bearing Retainer | 500. Mechanical Seal |
| 10. Intermediate   | 31. Impeller     | 160. Tie Bolt Assembly | 230. Bearing          | 600. Mechanical Seal |
| 11. Intermediate   | 35. Centerbody   | 188. Nut               | 231. Bearing          |                      |
| 12. Intermediate   | 36. Centerbody   | 200. Shaft             | 295. Grease Fitting   |                      |

MATERIALS

ITEM	0E	4B
Casing-Wetted	Cast Iron	316 SS
Intermediates	Cast Iron	316 SS
Impeller(s)	316 SS	316 SS
Centerbody	Cast Iron	316 SS
Shaft	420 SS QT	316 SS
Shaft Sleeves	N/A	N/A
Shaft Sealing	AHF <sup>6</sup>	AHF <sup>6</sup>
Casing-Non Wetted	Cast Iron	Cast Iron

<sup>6</sup>AHF = single seal with viton orings, carbon vs. SS faces

**BASE ASSEMBLY**

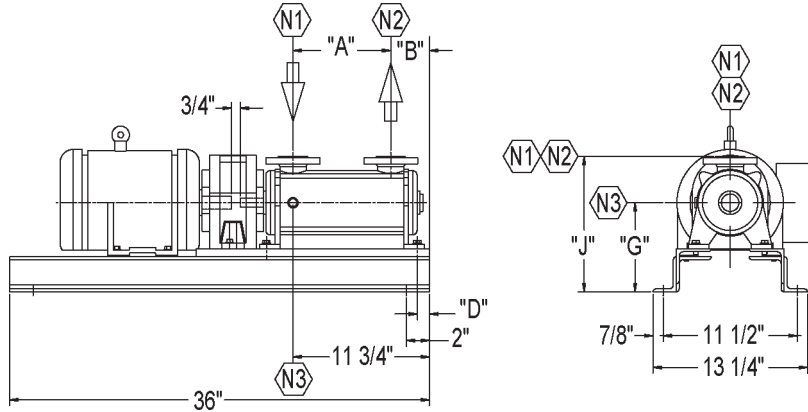

Nozzle Schedule				
Nozzle	Size	Qty.	Description	Service
N1	1-1/4"	1	FNPT	Suction
N2	1-1/4"	1	MNPT	Vent
N3	1/2"	1	FNPT	Service Liquid

SIHI Pump Model No.	Motor HP/RPM	Motor Frame Size	Baseplate	Approx Shipping Weight	A	B	D	G	J
LPHR-25003	2 / 3500	145T F2	B2208-41	138	6 3/8"	5 1/4"	3"	7"	10 7/8"
LPHR-25007	3 / 3500	182T F2	B2208-42	206	8 3/8"	3 3/8"	1"	7 5/8"	11 5/8"

Dimensions subject to change, consult factory for certified drawing if required.

**XBAR STANDARD PACKAGE**

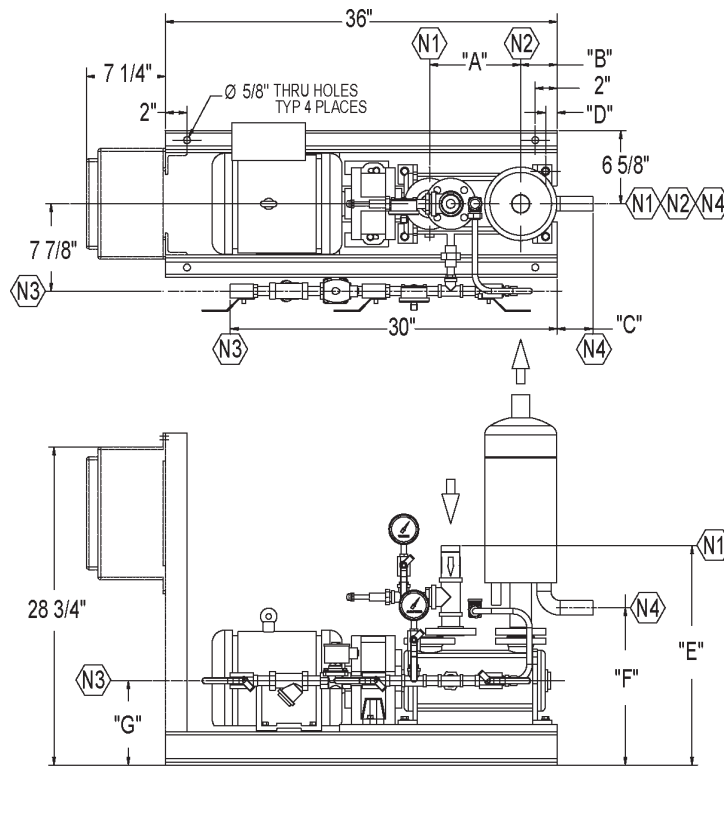

Nozzle Schedule				
Nozzle	Size	Qty.	Description	Service
N1	1-1/4"	1	FNPT	Suction
N2	1-1/4"	1	MNPT	Vent
N3	1/2"	1	FNPT	Service Liquid
N4	1"	1	MNPT	Overflow

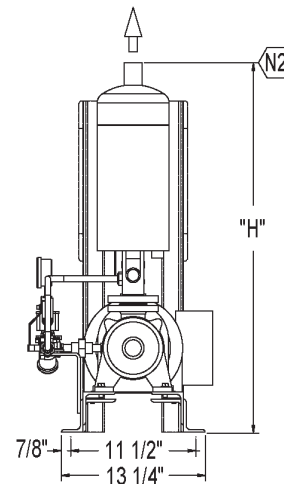

System Model No.	Motor HP/RPM	Motor Frame Size	Xba Tank Model No.	Baseplate	Approx Shipping Weight	A	B	C	D	E	F	G	H
XBAR-25003	2 / 3500	145T F2	0340	B2208-41	223	6 3/8"	5 1/4"	1 3/8"	3"	19 1/8"	13 1/2"	7"	32 3/4"
XBAR-25007	3 / 3500	182T F2	0340	B2208-42	291	8 3/8"	3 3/8"	3 1/4"	1"	19 3/4"	14 1/4"	7 5/8"	33 1/2"

Dimensions subject to change, consult factory for certified drawing if required.

All data subject to change without notice.

03.LPH 25000.03

Printed in U.S.A.



DATA-LPH 25000-2018MAR19  
© 2018 Flowserve Canada Corp.

**XBAR STANDARD PACKAGE MODULAR CONSTRUCTION**

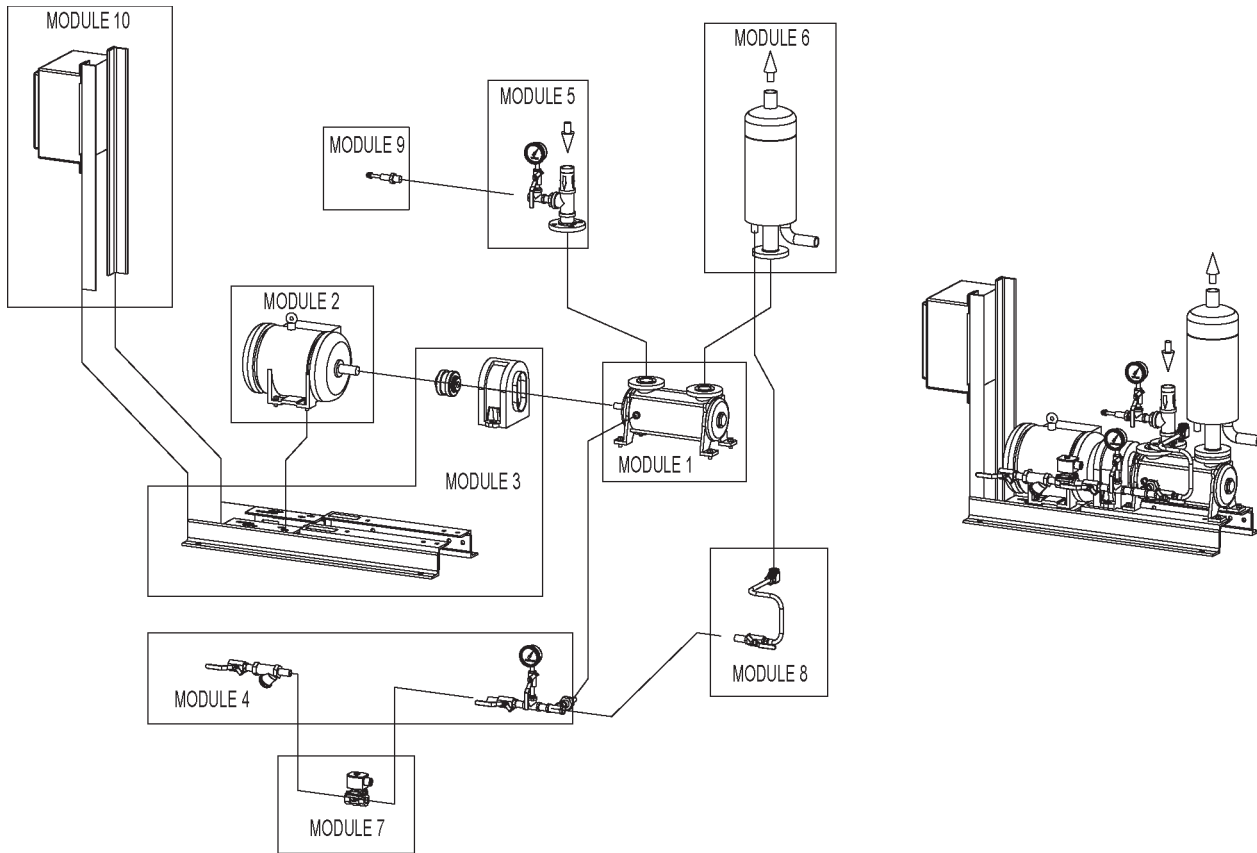

Pump Series:		25000 Series			
Module	Description	Details	Module Standard Construction Options		
Module 1	Pump	Material	0A	0E	4B
Module 2	Motor	HP	2.0		3.0
		RPM	3500		
		Enclosure	TEFC		EXPF
		Voltage	208-230/460	575	115/230
		Phase	3	3	1
Module 3	Base Assembly	Base / Coupling / Guard	Rail Base & Flex Coupling & Guard to OSHA Guidelines		
Module 4	Service Liquid Line (less solenoid valve)	Valve / Piping	Bronze / CS	CS / CS	Stainless / Stainless
Module 5	Inlet Vacuum Line	Valve / Piping	Bronze / CS	CS / CS	Stainless / Stainless
Module 6	Discharge	Separator / Piping	CS / CS		Stainless / Stainless
Module 7	Solenoid Valve	Enclosure	NEMA 4		NEMA 7
		Voltage	24VDC	120V/60Hz	110V/50Hz
		Material	Bronze		Stainless Steel
Module 8	Recirculation Line	Valve / Tubing	Bronze / Bronze	CS / CS	Stainless / Stainless
Module 9	Vacuum Relief Valve	Material	Bronze	Iron	Stainless Steel
Module 10	Control Panel	Enclosure	NEMA 4		NEMA 7
		Voltage	230	460	575