



Logix™ 3800e Digital Positioner FCD AIIOM000001 02/21

**Logix™ 3800e**  
Digital Positioner

FCD AIIOM000001 02/21

**USER INSTRUCTIONS**  
**Installation**  
**Operation**  
**Maintenance**  
**Safety**



**Experience In Motion**



This page intentionally left blank.

## CONTENTS

1	QUICK START GUIDE .....	4
2	SAFETY INFORMATION .....	9
3	PRE-INSTALLATION .....	10
4	INSTALLATION – MOUNTING .....	13
5	INSTALLATION - TUBING.....	19
6	INSTALLATION – ELECTRICAL CONNECTIONS (HART).....	21
7	OPERATION - HOW IT WORKS.....	23
8	OPERATION – DIP SWITCH CONFIGURATION.....	26
9	OPERATION – CALIBRATION AND CONTROL.....	27
10	OPERATION – USER INTERFACE.....	28
11	MAINTENANCE – TROUBLESHOOTING.....	32
12	MAINTENANCE - REPAIR.....	34
13	MAINTENANCE - HELP FROM FLOWSERVE .....	37
14	POSITIONER SPECIFICATIONS.....	38
15	HAZARDOUS LOCATION SPECIFICATIONS.....	42
	APPENDIX A – LCD MENU TREE OVERVIEW.....	47
	APPENDIX B – LCD MENU TREE DESCRIPTIONS .....	48
	APPENDIX C – PROGRAMMED FLOW CHARACTERIZATION OPTIONS.....	53
	APPENDIX D – 4-BLINK STATUS CODES .....	55
	APPENDIX E – STATUS CODE DESCRIPTIONS .....	57
	APPENDIX F – HOT KEYS.....	66
	APPENDIX G - HOW TO ORDER.....	68

1
2
3
4
5
6
7
8
9
10
11
12
13
14
15
A
B
C
D
E
F
G

# 1 QUICK START GUIDE

## 1.1 Logix 3800e Positioner Features

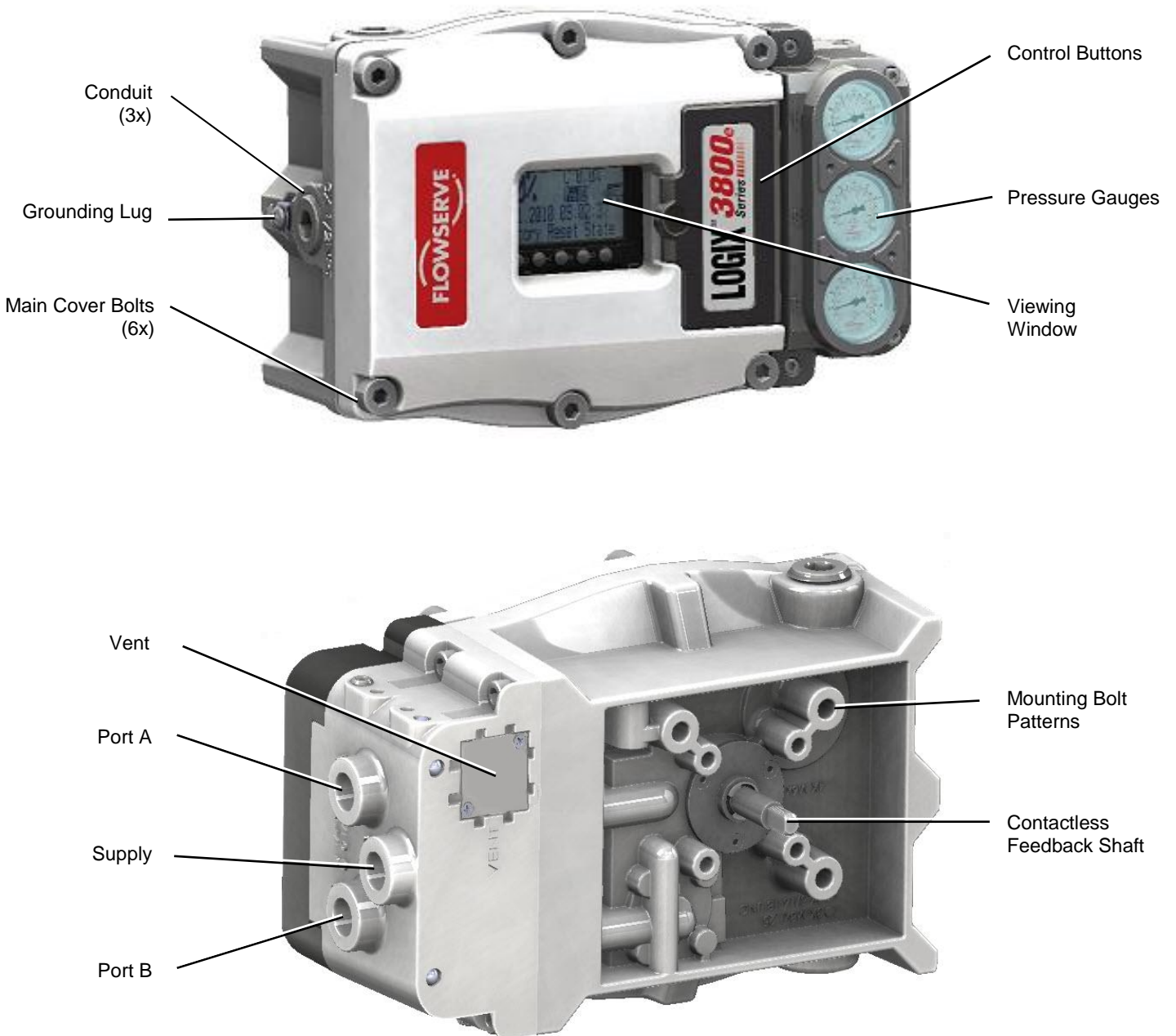
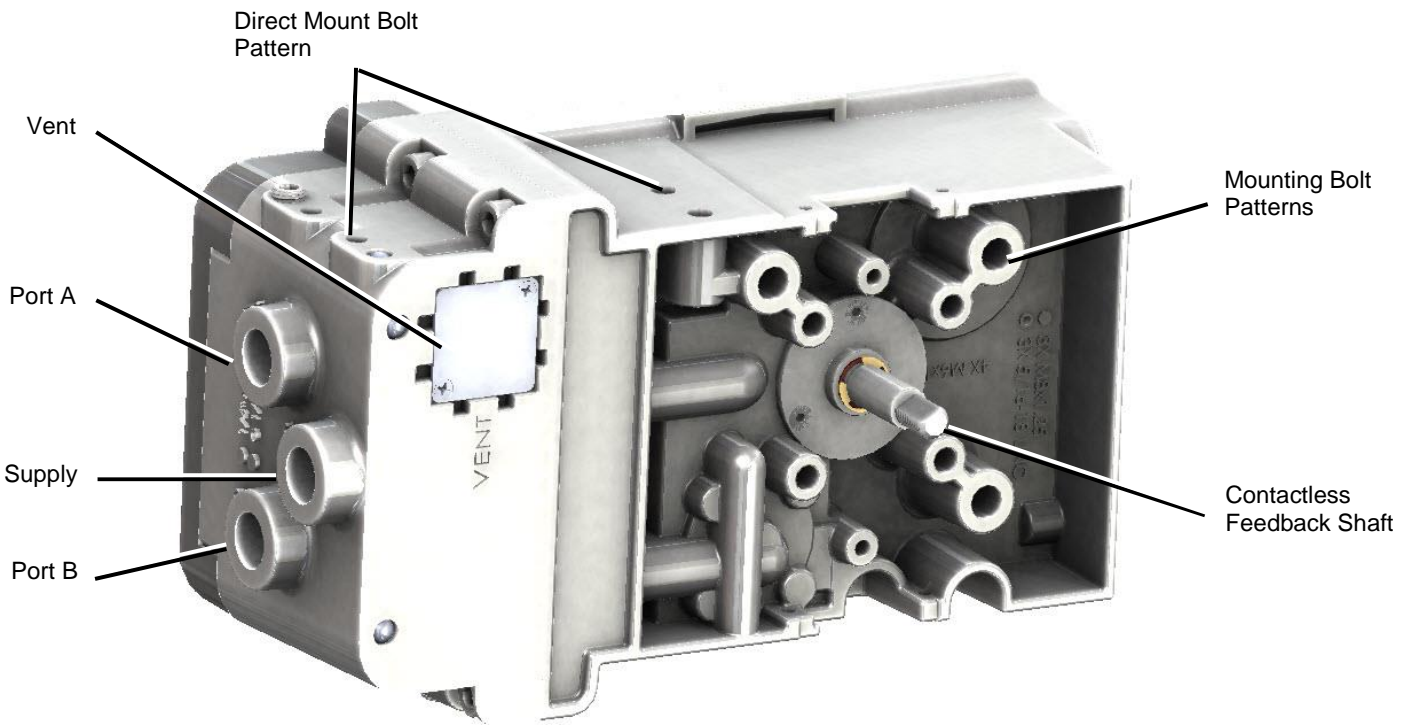

Figure 1: Logix 3800e External Positioner Features (EX and SS)



**Figure 2: Logix 3800e External Positioner Features (IS)**

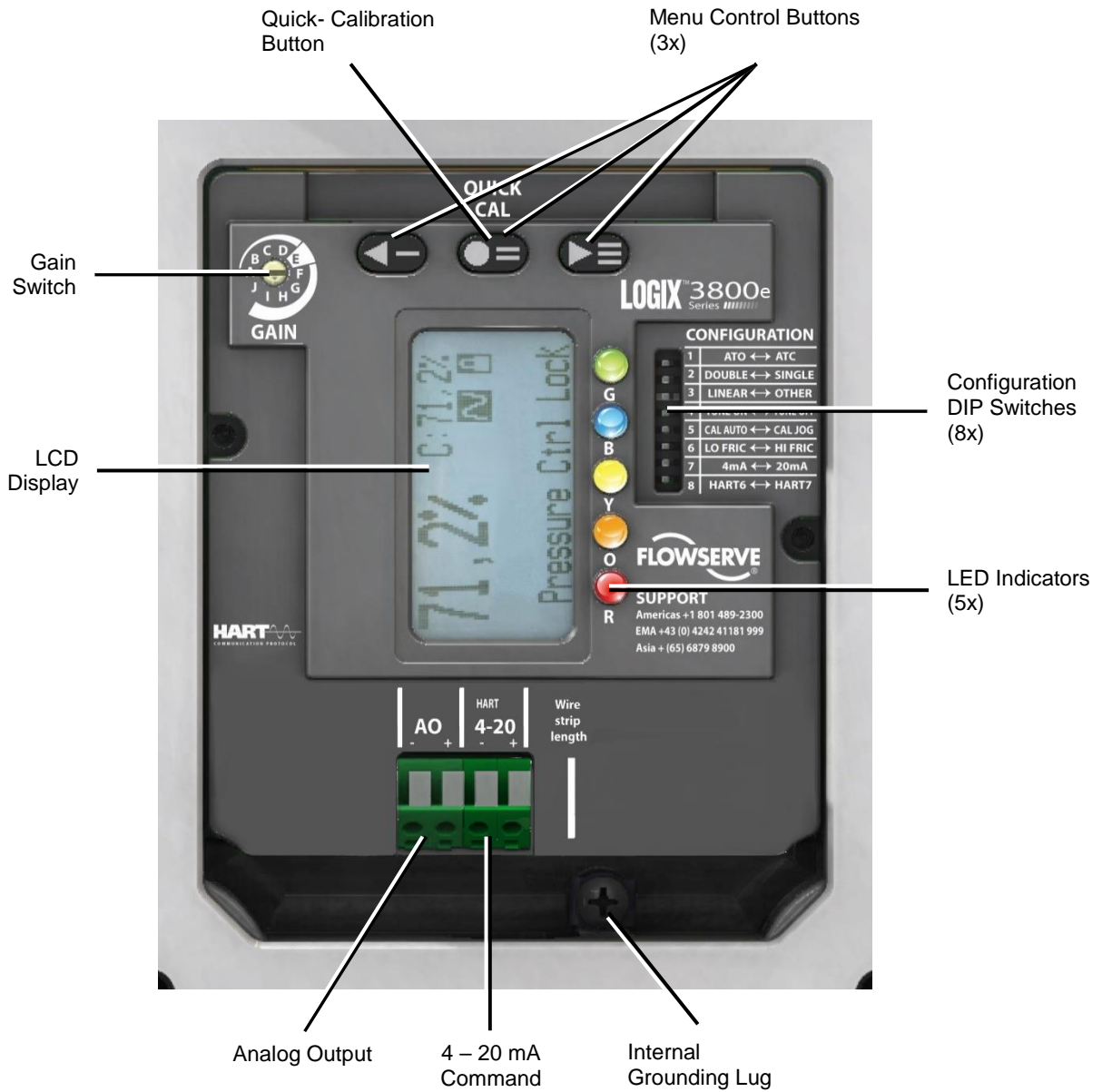

Figure 3: Logix 3820e (HART) Internal Positioner Features

## 1.2 Safety

**⚠ CAUTION:** Before installation, read all safety related information in section 2 Safety Information.

## 1.3 Installation

### MOUNTING

Securely mount the positioner to the actuator using the bolt pattern on the back of the positioner or use the direct mount block option. See section 4, Installation – Mounting, for more detail.

### FEEDBACK

Connect feedback linkage. Align the follower arm to move freely within the expected range of valve travel. Over-rotating the feedback shaft will not damage the unit.

### PNEUMATIC CONNECTIONS

Connect pneumatic ports A and B to the actuator. Port A should typically be connected to the side of the actuator opposing the actuator spring. With air supplied, but no electrical power to the system, port A will vent, and leave port B pressurized. For single acting actuators, connect to port A and plug port B. See section 5, Installation - Tubing, for more detail.

**⚠ CAUTION:** Connecting the supply air may cause the valve to move. Before connecting supply air, ensure the valve is isolated.

Connect port S to a clean, filtered air supply. See section 14, Positioner Specifications, for air cleanliness specifications.

### ELECTRICAL CONNECTIONS (HART)

**⚠ CAUTION:** Connecting the 4-20 mA signal may cause the valve to move. Before connecting electrical signal, ensure the valve is isolated.

Connect a 4-20 mA signal to the terminals labeled “4-20” or the tabs labeled “HART.” A signal above 3.8 mA will activate the positioner. LEDs on the positioner will light up indicating power is connected.

## 1.4 Configuration

Set the configuration dip switches. See section 8, Operation – Dip Switch Configuration, for more detail.

### AIR ACTION DIP SWITCH (ATO ◀▶ ATC)

For increasing pressure in port A to open the valve (air to open) select “ATO.” For increasing pressure in port A to close the valve (air to close) select “ATC.”

### ACTUATOR SWITCH (DOUBLE ◀▶ SINGLE)

For double-acting actuators select “DOUBLE.” For single-acting actuators, select “SINGLE.”

### CHARACTERIZATION SWITCH (LINEAR ◀▶ OTHER)

For a linear relationship between the command signal and the position of the valve, select “LINEAR.” To customize the characterization curve, select “OTHER.” Other curves can be chosen using the LCD menu, a handheld device, or DTM. See Appendix C – Programmed Flow Characterization Options for a table and graph describing the “OTHER” options.

### AUTO TUNE SWITCH (TUNE ON ◀▶ TUNE OFF)

For the QUICK-CAL calibration to automatically select custom tuning parameters, select TUNE ON (preferred). For default tuning parameters, select TUNE OFF.

### JOG CALIBRATION SWITCH (CAL AUTO ◀▶ CAL JOG)

For valves with a mechanical stop at the fully opened position (most valves), select CAL AUTO. For valves with no mechanical stop, select CAL JOG. This allows the user to set the upper limit of travel by jogging the position manually.

### VALVE STABILITY SWITCH (LO FRIC ◀▶ HI FRIC)

For valves with normal friction, select LO FRIC. For valves with very high friction, select HI FRIC.

### SIGNAL AT CLOSED SWITCH (HART) (4mA ◀▶ 20mA)

For a 4mA signal to move the valve to a closed position, select 4mA. For a 20mA signal to move the valve to closed, select 20mA.

### HART SWITCH (HART) (HART 6 ◀▶ HART 7)

For HART 6 protocol, select HART6. For HART 7 protocol, select HART7.



## 1.5 Calibration

**⚠ CAUTION:** *During the QUICK-CAL operation the valve may stroke unexpectedly. Notify proper personnel that the valve will stroke, and make sure the valve is properly isolated.*

### QUICK-CAL

The QUICK-CAL  button is used to initiate an automatic stroke calibration. This stroke calibration determines the closed (0%) and open (100%) positions of the valve and gathers information about the response of the valve to determine the control gains. The gains are automatically set. After a QUICK-CAL calibration, the positioner is ready to control.

To perform a QUICK-CAL, press and hold the QUICK-CAL  button for approximately 3 seconds, then release.

During the calibration, the LED lights will flash Yellow-Red-Yellow-Green indicating the calibration is in progress. After the calibration is complete, the LED lights should flash Green-Green-Green-Green indicating a successful calibration.

### GAIN SWITCH

After the calibration, (and at any time during operation), fine tune the gains by adjusting the Selectable GAIN Switch. Selecting "A" through "D" will provide a more stable or slower response. Selecting "F" through "J" will provide a more active or quicker response. The "E" position is the default and is typically more stable.

--- END OF QUICK START GUIDE ---



## 2 SAFETY INFORMATION





### 2.1 Using This Document

Product users and maintenance personnel should thoroughly review this manual before installing, operating, or performing any maintenance on the positioner.

The following instructions are designed to assist in unpacking, installing and performing maintenance as required on Logix™ 3800e positioners. Logix 3800e is the term used for all the positioners herein; however, specific numbers indicate features specific to model (i.e., Logix 3820e indicates that the positioner has HART®).

Separate Flow Control Products User Instructions cover the valve, actuator, or other portions of the system and other accessories. Refer to the appropriate instructions when this information is needed. The design of FLOWSERVE valves, actuators, and accessories are for specific applications considering medium, pressure, and temperature in most cases. For this reason, do not use them in other applications without first contacting the manufacturer.

### 2.2 Terms Concerning Safety

The safety terms  **NOTE**,  **CAUTION**, and  **DANGER** are used in these instructions to highlight particular hazards and to provide additional information on aspects that may not be readily apparent.  **DANGER** and  **CAUTION** notes must be strictly followed to avoid possible injury to personnel or damage to equipment or property.

 **NOTE:** *Indicates and provides additional technical information, which may not be obvious.*

 **CAUTION:** *Proper precautions must be observed to avoid minor personal injury and property damage.*

 **DANGER:** *Indicates that death, severe personal injury and/or substantial property damage can occur if proper precautions are not taken.*

Compliance with notes about installation, operation, maintenance and technical documentation (e.g. in the operating instruction, product documentation or on the positioner) is essential to avoid faults, which in themselves might directly or indirectly cause severe personal injury or property damage.

### 2.3 Protective Clothing

FLOWSERVE positioners use high-pressure gas to operate. Use eye protection when working around pressurized equipment. Follow proper procedures for working with natural gas.

 **DANGER:** *Standard industry safety practices must be adhered to when working on this or any process control product. Specifically, use personal protective equipment as warranted.*

### 2.4 Qualified Personnel

Qualified personnel are people who, because of their training, experience, instruction and their knowledge of relevant standards, specifications, accident prevention regulations and operating conditions, have been authorized by those responsible for the safety of the plant to perform the necessary work and who can recognize and avoid possible dangers.

In unpacking, installing and performing maintenance as required on FLOWSERVE products, product users and maintenance personnel should thoroughly review this manual before installing, operating, or performing any maintenance.

### 2.5 Valve and Actuator Variations

These instructions cannot claim to cover all details of all possible product variations, nor can they provide information for every possible example of installation, operation scenario, or maintenance requirement. Qualified personnel should follow the instructions provided and only use the product for its defined purpose. If clarification is needed or there are any uncertainties in this respect, particularly in the event of missing product-related information, immediately contact the appropriate Flowserve sales office. Contact information is listed at the back of this manual.

### 2.6 Spare Parts

Use only FLOWSERVE original components. FLOWSERVE cannot accept responsibility for any damages that occur from using components or fastening materials from other manufacturers. If FLOWSERVE products (especially sealing materials) have been in storage for longer periods, check them for corrosion or deterioration before using these products. See Appendix G - How To Order for more information.

### 2.7 Service / Repair

 **CAUTION:** *Proper precautions must be strictly observed to avoid possible personal injury and property damage.*

Modifying this product, substituting non-factory parts, or using maintenance procedures other than outlined in this instruction could drastically affect performance and be hazardous to personnel and equipment, and may void existing warranties.

There are moving parts between the actuator and the valve. To avoid injury FLOWSERVE provides pinch-point-protection in the form of cover plates, especially with side-mounted positioners. Special attention is required when removing these plates for inspection, service or repair. Refit the cover plates after completing work.

Logix 3800e positioner repair is limited to the replacement of sub-assemblies and circuit boards with FLOWSERVE-manufactured replacements as outlined in this manual.

**DANGER:** *Substitution with non-factory positioner components may impair intrinsic safety.*

**CAUTION:** *Before returning products to FLOWSERVE for repair or service, provide a certificate to FLOWSERVE which confirms that the product has been decontaminated and is clean; FLOWSERVE will not accept deliveries if a certificate is not provided (a form is available from FLOWSERVE).*

Apart from the operating instructions and the necessary accident prevention directives valid in the country of use, follow all recognized regulations for safety and good engineering practices.

## 2.8 Natural Gas Service

If a natural gas model positioner is ordered, then the use of natural gas as an actuation medium with a FLOWSERVE Logix 3800e positioner is acceptable.

**CAUTION:** *The natural gas used must be sweet natural gas. Use of sour natural gas may cause positioner to fail prematurely.*

**DANGER:** *The Logix 3800e is vented directly to atmosphere. The substitution of sweet natural gas as the air supply requires piping to route the exhausted natural gas to a safe environment. Refer to section 5.4, Venting, for venting details.*

## 3 PRE-INSTALLATION

### 3.1 Storage

It is mandatory to store FLOWSERVE control valves and instruments in a clean, dry environment. Prevent flooding of the equipment, including rainwater, that can pool in packaging materials. Prevent dirt or sand accumulation in the pneumatic and valve ports. Plastic caps are fitted to protect positioner ports from ingress of foreign materials. These caps should be removed before fitting with conduit or air supply lines.

If FLOWSERVE products have been in storage for longer periods, check them for corrosion or deterioration before using these products. The end user must provide fire protection for FLOWSERVE products.

**NOTE:** *The positioner is not IP66/NEMA 4X certified until installed and temporary plugs have been fitted with tubing, conduit or permanent plugs.*

### 3.2 Unpacking

While unpacking the valve and Logix 3800e positioner, check the packing list against the materials received. Each shipping container includes a list describing the system and accessories included.

In the event of shipping damage, contact the shipper immediately. Should any problems arise, please contact a FLOWSERVE Flow Control Division representative. Phone numbers are at the back of the manual.

Remove the plastic plugs (blue color) from the conduit and pneumatic ports before installing. Replace with plugs that will seal the opening using either ¼" NPT, ½" NPT or M20 threaded plug, depending on the housing, which is clearly marked.

**CAUTION:** *The plastic plugs in the conduit and pneumatic ports are intended only to protect the threads during shipment. Failure to replace these with a sealing plug may result in liquid and debris ingress and damage to the positioner.*

**DANGER:** *When lifting a valve/actuator assembly with lifting straps, be aware that the center of gravity may be above the lifting point. Therefore, support must be given to prevent the valve/actuator from rotating and falling. Failure to do so can cause serious injury to personnel or damage to nearby equipment.*

### 3.3 Pre-installation Inspection

When installing a positioner, check the feedback shaft for damage and that the plugs and cover are in place. If there is contamination in the positioner, clean the positioner components gently with a soft damp cloth. One may remove some parts for better access. Do not get water on the electronics assembly.

### 3.4 Label Verification

Verify that the labels match the intended application. See section 15, Hazardous Location Specifications, for more details.

**NOTE:** The installer should mark the checkbox on the label that is appropriate for the intended use of the Logix 3800e.

3

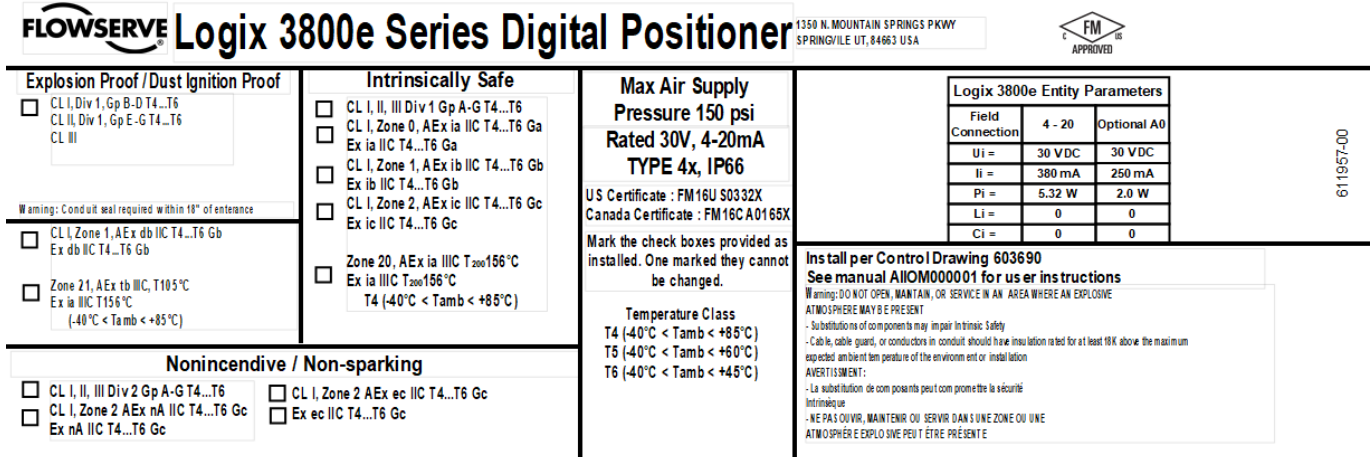

Figure 4: Certification Labels (Explosion Proof Housing)

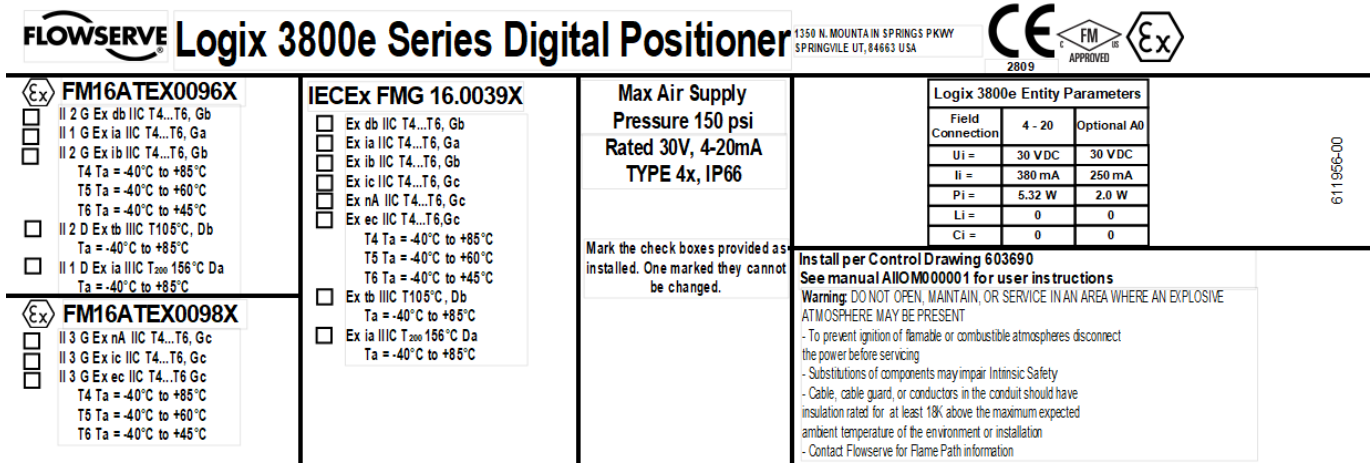

Figure 5: Certification Labels (Explosion Proof Housing)

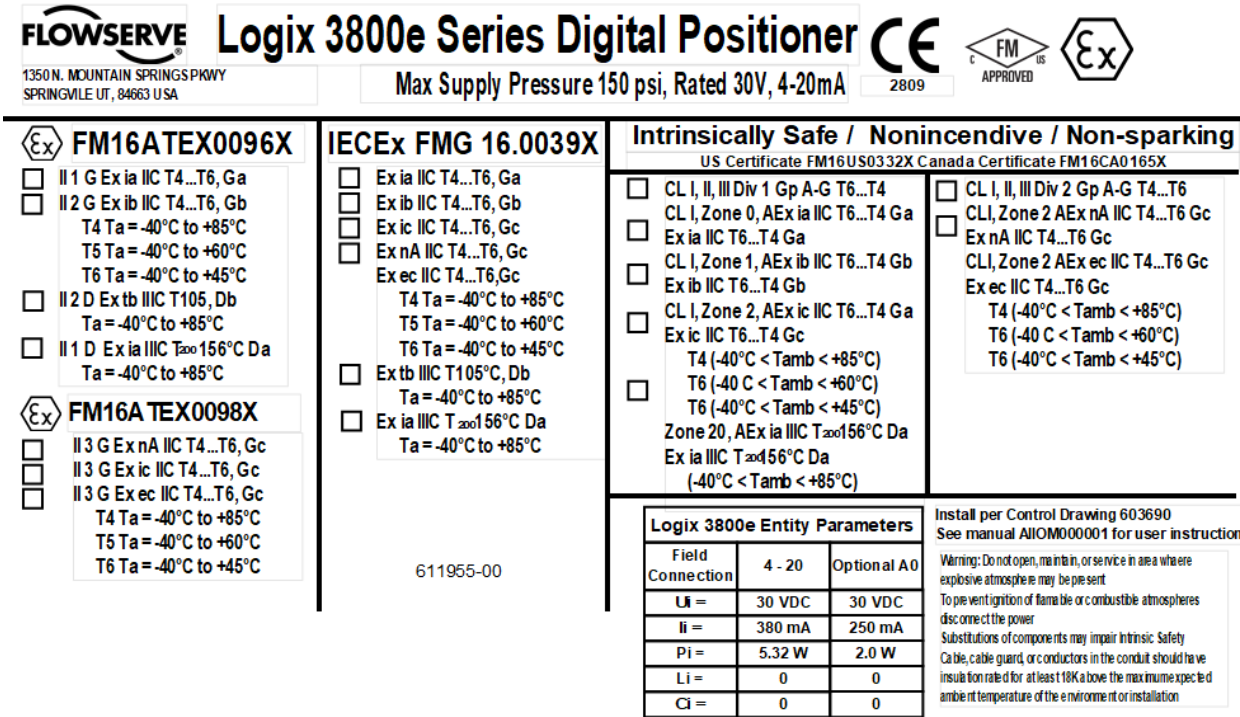

Figure 6: Certification Labels (Intrinsically Safe Housing)

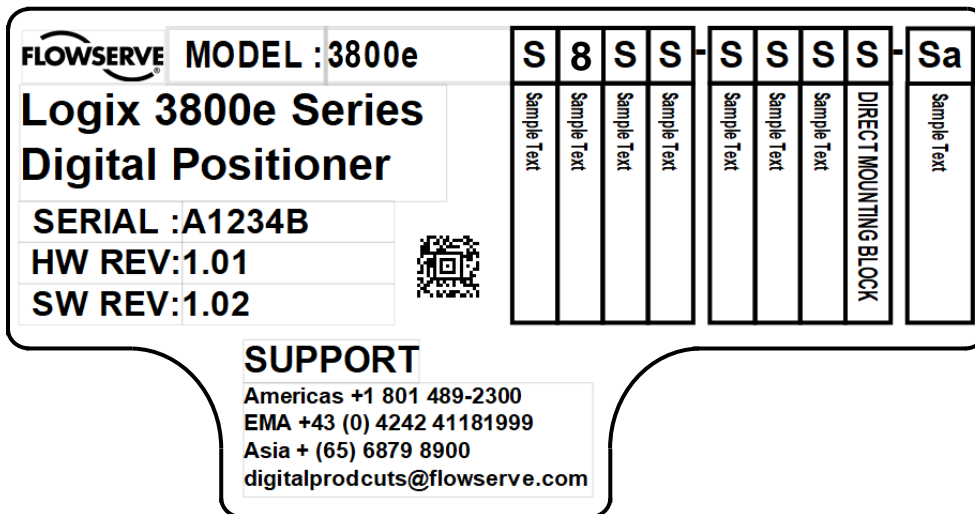

Figure 7: Model Code Label



## 4 INSTALLATION – MOUNTING

**NOTE:** The Logix 3800e positioner can be mounted in any orientation - with gauges on the left or right.

### 4.1 Mounting to Mark One Linear Valves

To attach a Logix 3800e positioner to a Valtek linear Mark I valve, refer to Figure 8: Mounting to Mark I Linear Valve and proceed as outlined below. Refer to Figure 9: Mounting Namur to Linear Valve if using a Namur shaft. Refer to Table 22: Linear Actuator Mounting Kits (D Shaft), APPENDIX G - HOW TO ORDER, for complete linear actuator mounting kit listings.

- 1 Remove washer and nut from follower pin assembly. Insert pin into the appropriate hole in follower arm, or locate the pin long the slot in the follower arm based on stroke length. The stroke lengths are located on the follower arm. Make sure the stamped side of the arm is toward the unthreaded end of the pin. Reinstall the lock washer and tighten the nut to complete follower arm assembly.
- 2 Slide the slot in the follower arm assembly over the flats on the position feedback shaft on the back of the positioner. The follower arm will be specific to a D shaft or a Namur shaft. Rotate the arm until the arm is pointing toward the side of the positioner with ports A, B, and Supply. Slide the lock washer over the threads on the shaft and tighten down the nut.

**NOTE:** The feedback shaft has a clutch mechanism that allows for over-rotation of the shaft for easy adjustments.

- 3 Align the bracket with the three outer mounting holes on the positioner. Fasten with 5/16-18 UNC bolts.
- 4 Screw one mounting bolt into the hole on the yoke mounting pad nearest the cylinder. Stop when the bolt is approximately 3/16" from being flush with the mounting pad.
- 5 Slip the large end of the slotted mounting hole in the back of the positioner/bracket assembly over the mounting bolt. Slide the small end of the teardrop under the mounting bolt and align the lower mounting hole.
- 6 Insert the lower mounting bolt and tighten the bolting.
- 7 Position the take-off arm mounting slot against the stem clamp mounting pad. Apply Loctite 222 to the take-off arm bolting and insert through washers into stem clamp. Leave bolts loose.
- 8 Center the take-off arm on the follower pin.
- 9 Align the take-off arm with the top surface of the stem clamp and tighten bolt. Torque to 120 in-lb.

**NOTE:** If mounted correctly, the follower arm should be horizontal when the valve is at 50% stroke and should move approximately  $\pm 30^\circ$  from horizontal over the full stroke of the valve. A stroke calibration error will occur if the positioner is mounted incorrectly, and the indicator lights will blink a Red-Red-Yellow-Green code indicating the position sensor has gone out of range on one end of travel, or the travel is too small. Reposition the feedback linkage or the positioner to correct the error.

**NOTE:** To virtually eliminate non-linearity, use the Linearization feature in the Custom Characterization page of the DTM.

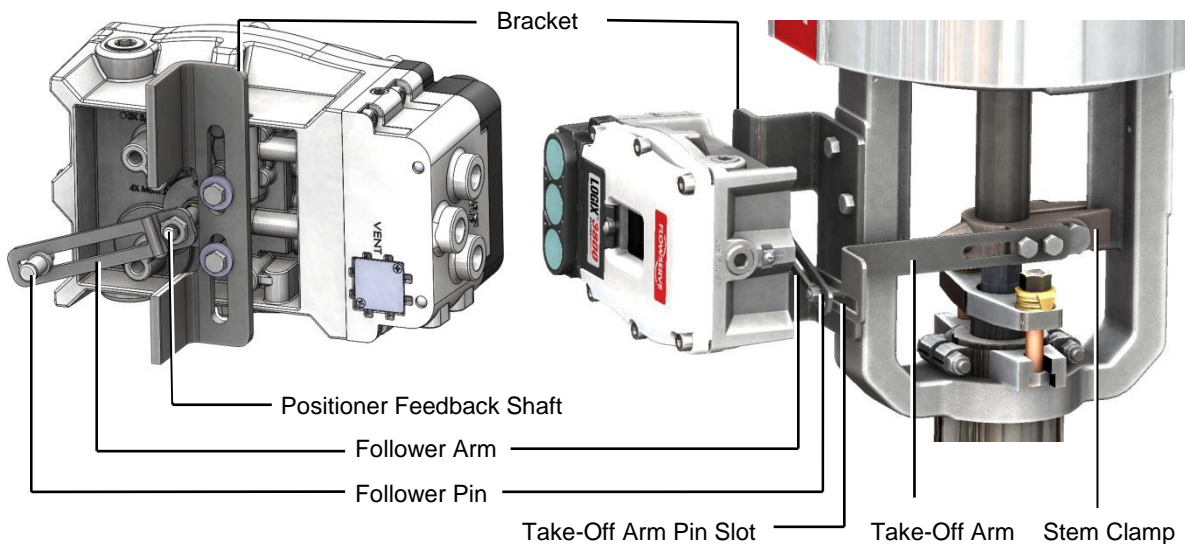
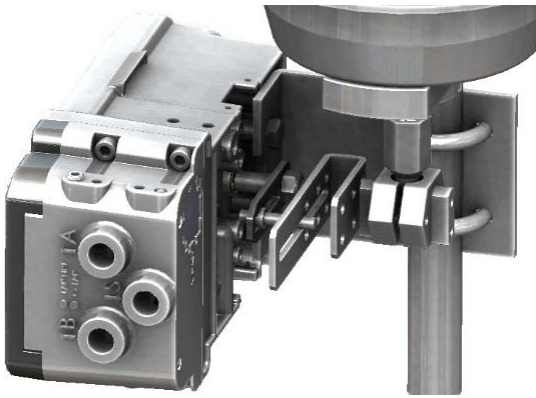

Figure 8: Mounting to Mark I Linear Valve



**Figure 9: Mounting Namur to Linear Valve**

**4.2 Mounting to Standard Valtek Rotary Valves**

The standard rotary mounting applies to Valtek valve/actuator assemblies that do not have mounted volume tanks or hand-wheels. The standard mounting uses a linkage directly coupled to the valve shaft. This linkage has been designed to allow for minimal misalignment between the positioner and the actuator. Refer to Figure 10: Valtek Rotary Follower Arm through Figure 13: Valtek Rotary Final Orientation.

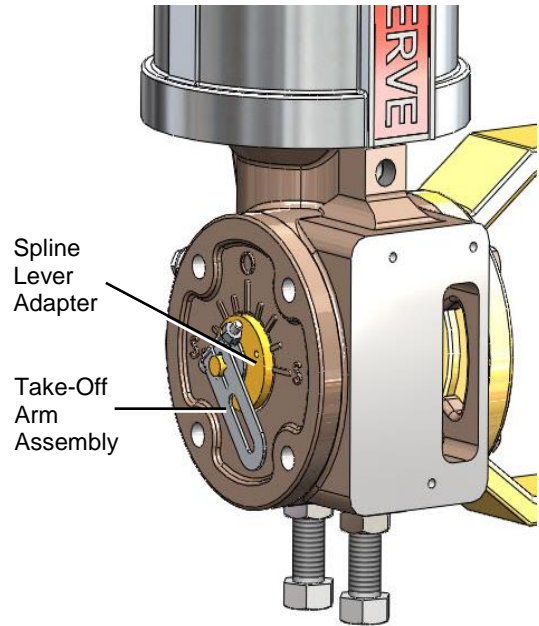

**Figure 11: Valtek Rotary Take Off Arm**

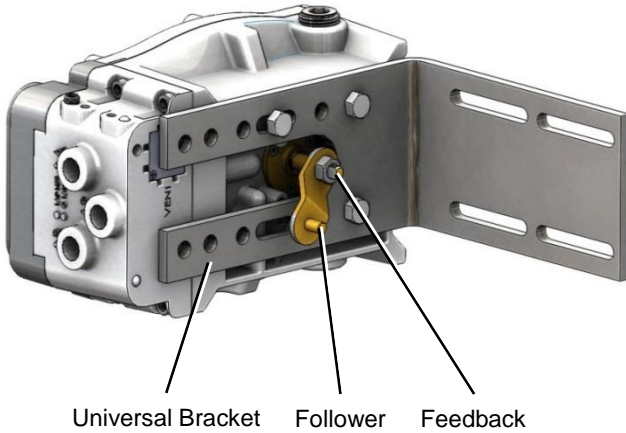

**Figure 10: Valtek Rotary Follower Arm**



**Figure 12: Valtek Rotary Mounting**

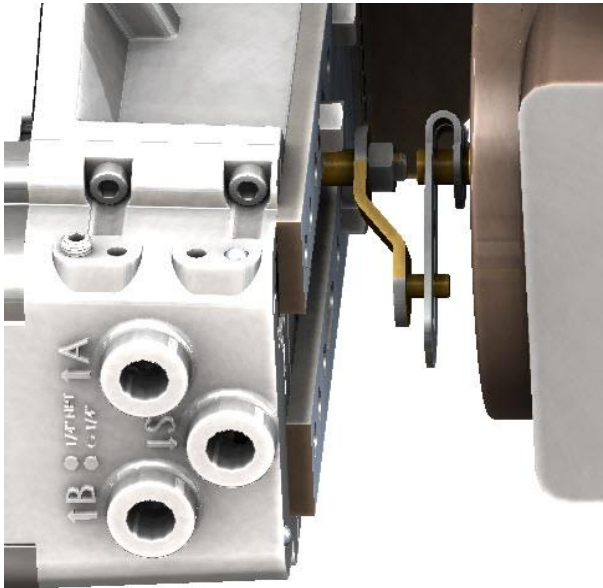

**Figure 13: Valtek Rotary Final Orientation**

- 1 Fasten the spline lever adapter to the splined lever using two 4-40 screws.
- 2 Slide the take-off arm onto the spline lever adapter shaft, orienting the arm to the current valve position. Insert the screw with star washer through the take-off arm and add the second star washer and nut and tighten.
- 3 Attach follower arm to positioner feedback shaft using the 10-32 nut.
- 4 Rotate the follower arm so that the follower pin will slide into the slot on the take-off arm. Adjust the bracket position as needed noting the engagement of the follower pin and the take-off arm slot. The pin should extend approximately 2 mm past the take-off arm. When properly adjusted, securely tighten the bracket bolts.
- 5 Using three 5/16-18 UNC x 1/2" bolts, fasten positioner to the universal bracket.
- 6 Using a 1/2" end wrench and two 5/16-18 UNC X 1/2" bolts, attach the bracket to actuator transfer case pad. Leaving these bolts slightly loose will aid in final adjustments.
- 7 Rotate follower arm so the follower pin will slide into the slot on the take-off arm. Over-rotate the follower arm if needed, so the arm moves freely through the intended travel.

**NOTE:** The feedback shaft has a clutch mechanism that allows for over-rotation of the shaft for easy adjustments.

- 8 Adjust the bracket position as needed noting the engagement of the follower pin and the take-off arm slot. The pin should extend approximately 1/16" past the take-off arm. When properly adjusted, securely tighten the bracket bolts.

- 9 If calibration fails, retry the calibration. Exceeding the feedback values will cause it to continue to fail, and the arm must be adjusted away from the positioner's limits. Rotate the feedback shaft so that the full free travel of the feedback shaft is in the range of the actuator movement. Optionally, continue to attempt the calibration. Each calibration attempt adjusts the acceptable limits, and it should eventually pass.

**CAUTION:** Remember to remove the air supply before re-adjusting take-off arm.

**NOTE:** If mounted correctly to a standard valve, the follower arm should be horizontal when the valve is at 50% stroke and should move approximately ±30° from horizontal over the full stroke of the valve.

**NOTE:** To improve linearity of feedback, use the Linearization feature on the Custom Characterization page of the DTM.

### 4.3 Mounting to MaxFlo Rotary Valves

- 1 Slide the take-off arm onto the shaft. Insert the screw with the star washer through the take-off arm and add the second star washer and nut. Tighten the nut with a socket, so the arm is just snug on the shaft but still able to rotate. Tightening will occur after linkage is correctly oriented. Refer to Figure 14: MaxFlo Take Off Arm.

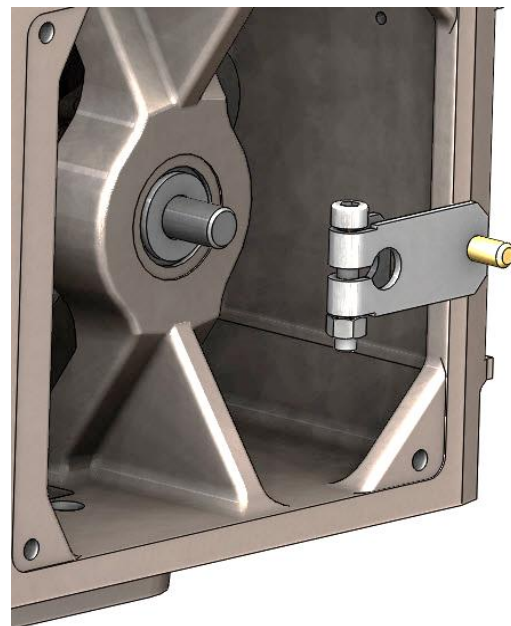

**Figure 14: MaxFlo Take Off Arm**



- 2 Attach the mounting plate to the positioner using four screws and attach follower arm to positioner feedback shaft. See Figure 15: MaxFlo Follower Arm and Figure 16: MaxFlo Connection.

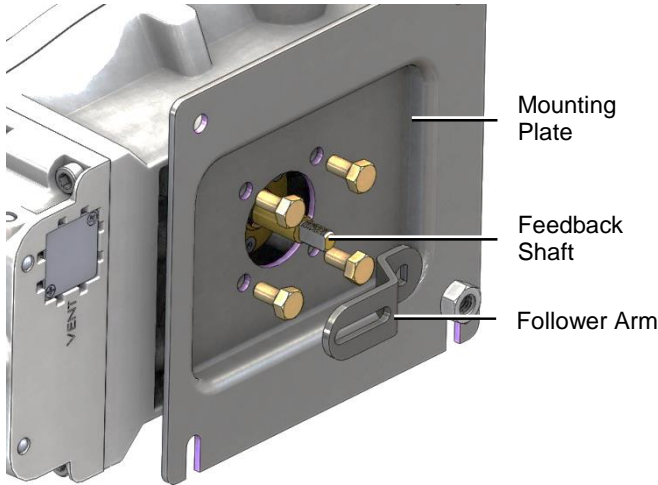
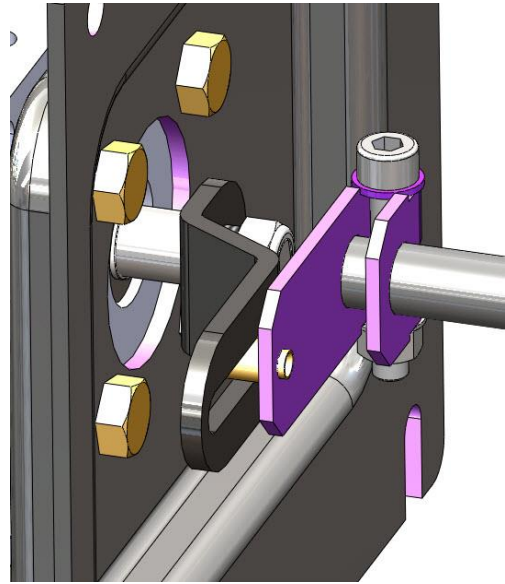

**Figure 15: MaxFlo Follower Arm**



**Figure 16: MaxFlo Connection**

- 3 Rotate the follower arm so that the take-off pin will slide into the slot on the follower arm. Adjust the bracket position as needed noting the engagement of the follower pin and the take-off arm slot. The pin should extend approximately 2 mm past the take-off arm. When properly adjusted, securely tighten the bracketing bolts. See Figure 17: MaxFlo Assembly.



**Figure 17: MaxFlo Assembly**

**NOTE:** The feedback shaft has a clutch mechanism that allows for over-rotation of the shaft for easy adjustments.

- 4 If calibration fails, retry the calibration. If it still fails, remove power from the positioner, disconnect the air, and then reconnect the positioner and continue to attempt the calibration. Each calibration attempt adjusts the acceptable limits, and it should pass eventually.

#### 4.4 Mounting to Rotary NAMUR Valves

- 1 Attach the mounting plate to the positioner using four screws. See Figure 18: AutoMax Bracket.

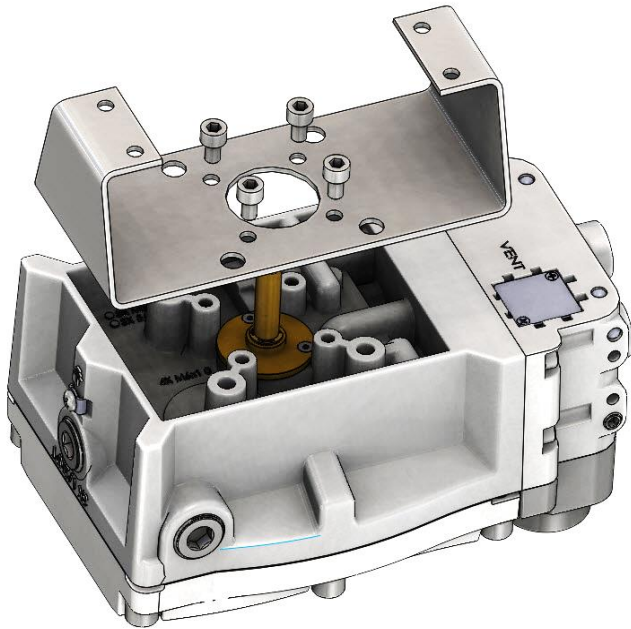

**Figure 18: AutoMax Bracket**

- 2 Rotate the feedback shaft to match the orientation of the receiver on the actuator.

**NOTE:** *The feedback shaft has a clutch mechanism that allows for over-rotation of the shaft for easy adjustments.*

- 3 Mount the positioner onto the actuator using the washers and nuts as shown in Figure 19: AutoMax Assembly and Figure 20: MaxFlo 4 Assembly.
- 4 If calibration fails, retry the calibration. If it still fails, remove power from the positioner, disconnect the air, and then reconnect the positioner and continue to attempt the calibration. Each calibration attempt adjusts the acceptable limits, and it should eventually pass.

**CAUTION:** *Remember to remove the air supply before re-adjusting take-off arm.*



**Figure 19: AutoMax Assembly**

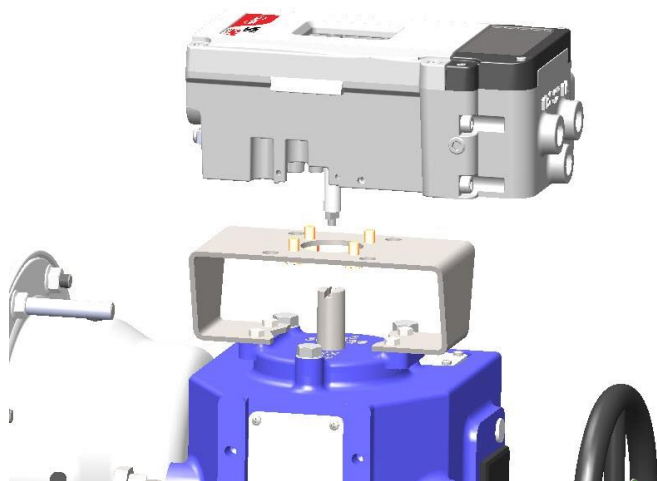

**Figure 20: MaxFlo 4 Assembly**

## 4.5 Direct Mount

Direct mount allows the positioner to be mounted directly to the actuator without tubing. See your Flowserve sales representative for actuator options.

- 1 Assemble the direct mount block onto the positioner. See figure 23.
- 2 Ensure the feedback shaft and take-off arm are properly aligned.
- 3 If the actuator is designed as an ATO system, remove the plug from the positioner's direct air port, and insert a 1/4" plug into positioner ports A and B.
- 4 Mount the positioner assembly to the actuator that is compatible with Flowserve direct mount devices.



**Figure 21: Direct Mount on IS Housing**

## 5 INSTALLATION - TUBING

After mounting to the actuator, tube the positioner using the appropriate compression fitting connectors. For best performance, use 10 mm (3/8 inch) tubing for 645 square cm (100 square inches) actuators or larger.

### 5.1 Determine Air Action

When an air supply is present, and the relay is energized, port “A” delivers air. Typically, the tubing from port “A” is connected to side of the actuator that results in the air compressing the actuator spring. When tubed this way, the spring is designed to return the valve to the fail-safe state should supply air or power to the unit fail or be turned off.

Tube the port labeled “A” to the side of the actuator that must receive air to begin moving away from the fail-safe state.

If air from “A” should open the valve, set the Air Action configuration DIP switch on the positioner to Air-to-Open, otherwise set it to Air-to-Close. The Air-to-Open and Air-to-Close selection is only a reflection of the tubing. When selecting air action during configuration, the selection tells the control which way the actuator was tubed.

If the valve is double acting, port the valve labeled “B” to the other side of the actuator, otherwise plug port “B”.

**DANGER:** Proper tubing orientation is critical for the positioner to function correctly and have the correct failure mode. The backward tubing could cause an unsafe failure mode.

#### Example: Tubing Linear Double-Acting Actuators

For a linear air-to-open actuator, the tubing from port “A” is connected to the bottom side of the actuator (closest to the valve). Tube the “B” port of the positioner to the top side of the actuator. See Figure 22: Linear, Double Acting, Air to Open. For a linear air-to-close actuator the tubing configuration is reversed.

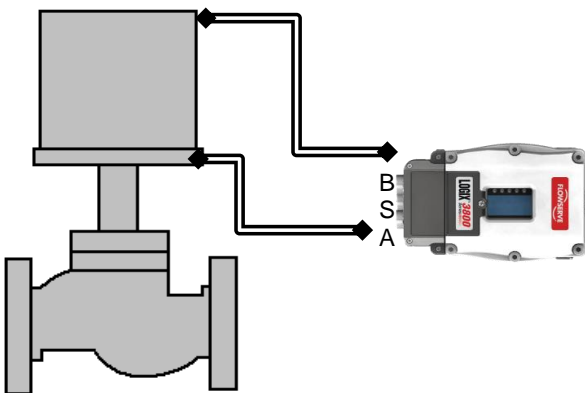

Figure 22: Linear, Double Acting, Air to Open

#### Example: Rotary Double-Acting Actuators

For a rotary actuator, rout tubing from Port “A” to the far side of the actuator and tubing from port “B” to the side of the actuator closer to the transfer case. Follow this tubing convention regardless of air action. On rotary actuators, the transfer case orientation determines the air action. See Figure 23: Rotary, Double Acting, Air to Open.

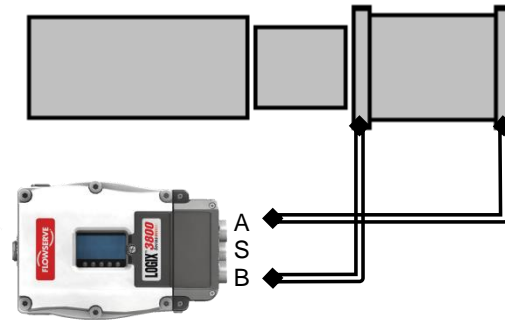

Figure 23: Rotary, Double Acting, Air to Open

#### Example: Tubing Single-Acting Actuators

For single-acting actuators, tubing for port “A” is always to the pneumatic side of the actuator regardless of air action. Port B is plugged. See Figure 24: Linear, Single Acting, Air to Open.

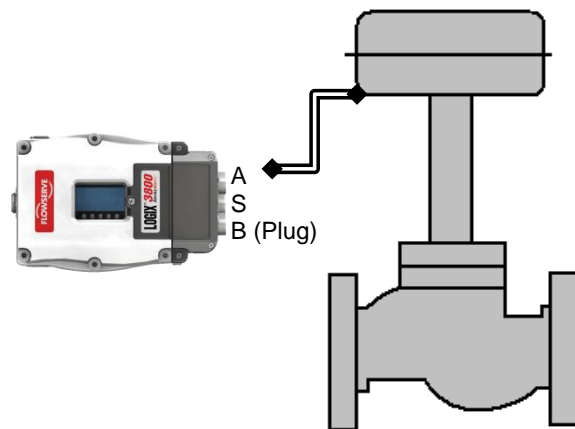

Figure 24: Linear, Single Acting, Air to Open

### 5.2 Connect Supply Port

The housing indicates the positioner ports’ threads (either G 1/4 or 1/4 NPT).

Always install a coalescing filter in the supply gas line to maintain the recommended air quality. If dirty air is a possibility, always install an air filter. There are small screens installed in the positioner passages, which remove medium and coarse size dirt from the pressurized air. If necessary, they are readily available for cleaning.

If the customer is using the diagnostic features of the Logix 3800e, a supply regulator will provide the best result. In applications where the supply pressure is higher than the maximum actuator pressure rating a supply, the regulator is required to lower the pressure to the actuator's maximum rating.

**DANGER:** Exceeding the maximum actuator supply pressure may cause the actuator to explode, causing death, injury or property damage.

### 5.3 Purging

Purging allows the non-pressurized side of a single acting actuator to fill with clean exhaust gas instead of moist atmospheric air. This configuration helps prevent corrosion of actuator components in harsh environments. Figure 25 shows the purging configuration. Contact your local FLOWERVE Representative for more information regarding the purging option.

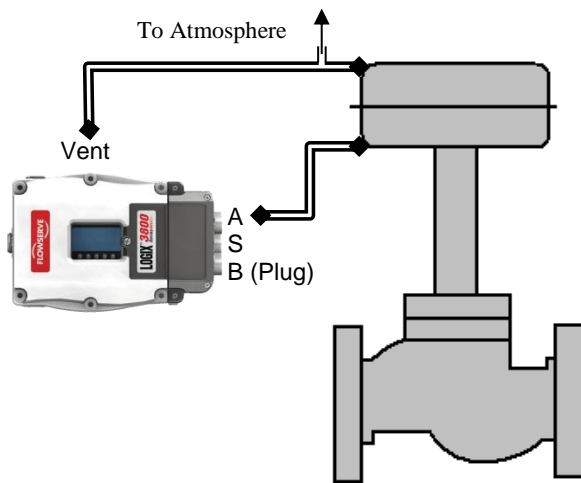

Figure 25: Purging

### 5.4 Venting

A Logix 3800e positioner is vented directly to the atmosphere. When supply air is substituted with sweet natural gas, piping must be used to route the exhausted natural gas to a safe environment.

The exhaust port is located on the back of the positioner. The port is tapped with a 1/4 NPT thread and covered with a protective cap. To control vented gas, remove the cap and connect the necessary tubing/piping to these ports. See Figure 26: Exhaust Vent. Refer to Table 1: Max. Recommended Vent Tubing Length(ft) with 1/2" Dia. Tubing for a list of tubing size recommendations

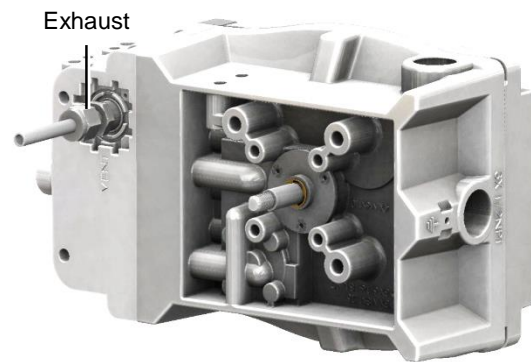

Figure 26: Exhaust Vent

This piping system may cause some positioner back pressure. The maximum allowable back pressure is 0.55 bar g (8.0 PSIG).

**NOTE:** It is not recommended to use 1/4" Tubing for venting any actuator positioner configuration due to the likelihood of positioner overshoot.

**CAUTION:** The back pressure in the main housing must never rise above 0.55 bar g (8.0 PSIG). This could cause the positioner to become unresponsive under some circumstances.

Table 1: Max. Recommended Vent Tubing Length(ft) with 1/2" Dia. Tubing

Actuator Size (in <sup>2</sup> )	Gain	Supply Pressure (PSI)		
		60	90	120
25	B	100	50	5
	E	25	3	-
100	E	65	25	13



## 6 INSTALLATION – ELECTRICAL CONNECTIONS (HART)

**⚠ CAUTION:** Connect only wires with compatible electrical signals to the terminals. Voltages or currents outside the specified range can damage the circuit boards.

### 6.1 Electrical Terminals

Figure 27 shows the terminals on the positioner unit labeled for HART protocol.



Figure 27: Terminal Diagram (HART)

### 6.2 Command Input (4-20 mA) Connection

Wire 4-20 mA current source to the input terminal labeled “HART 4-20”. The Logix 3820e has spring loaded terminal blocks that do not require tools. Depending on the current source, a HART filter may be required. See section 11, Maintenance – Troubleshooting.

**↻ NOTE:** The polarity of the terminals is labeled on the cover; however, the command input connection is polarity insensitive.

#### 6.2.1 Compliance Voltage

Output compliance voltage refers to the maximum voltage the current source can provide. A current loop system consists of the current source, wiring resistance, barrier resistance (if present), and the Logix 3820e impedance.

The Logix 3820e requires that the current loop system allows for a 10 VDC drop across the positioner at maximum loop current. The current loop system should have a minimum compliance voltage greater than 10 VDC and a maximum less than 32 VDC. The current operating range is from 4 to 20 mA. See Figure 28: Compliance Voltage.

To determine if the loop will support the Logix 3820e, perform the calculation in the following equation. The Available Voltage must be greater than 10VDC to support the Logix 3820e.

#### Equation 1

$$\text{Available Voltage} = \text{Controller Voltage (@Current}_{max}) - \text{Current}_{max} \times (R_{\text{barrier}} + R_{\text{wire}})$$

#### Example:

$$\text{Current}_{max} = 20\text{mA}$$

$$R_{\text{barrier}} = 300\Omega$$

$$R_{\text{wire}} = 25\Omega$$

$$\text{Available Voltage} = 19\text{ V} - 0.020\text{ A} \times (300\Omega + 25\Omega)$$

$$\text{Available Voltage} = 12.5\text{ V}$$

The available voltage (12.5 V) is greater than the required voltage (10.0 V) therefore; this system will support the Logix 3820e. The Logix 3820e has an input resistance equivalent to 500 Ω at a 20 mA input current.

**⚠ CAUTION:** Always limit the current for 4-20 mA operation. Never connect a voltage source directly across the Logix 3820e terminals. Permanent circuit board damage may occur.

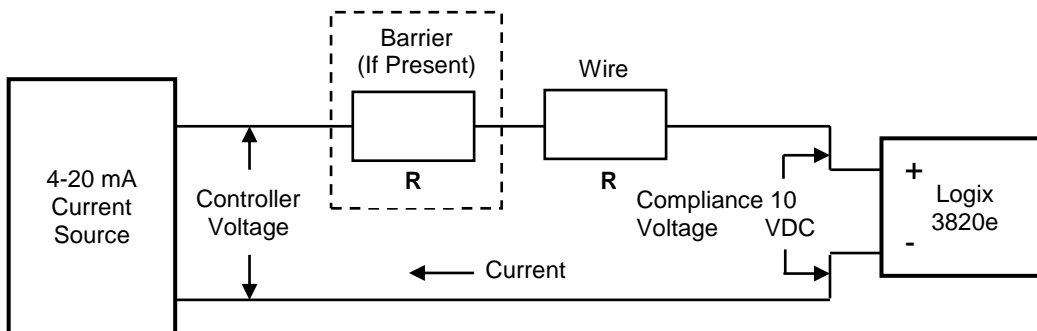

Figure 28: Compliance Voltage

### 6.2.2 Cable Requirements

The Logix 3820e digital positioner utilizes the HART Communication protocol. It is superimposed on the 4-20 mA current signal. The two frequencies used by the HART protocol are 1200 Hz and 2200 Hz. Calculate cable length restrictions to prevent distortion of the HART communication signal and cable capacitance. The cable length must be limited if the capacitance is too high. Selecting a cable with lower capacitance/foot rating will allow longer cable runs. In addition to the cable capacitance, the network resistance also affects the allowable cable length.

For installation practices, wire gauge sizes, and allowable cable lengths see the HART Field Communications Protocol Application Guide, HCF LIT 34.

The input loop current signal to the Logix 3820e digital positioner should be in shielded cable. By tying shields to ground at only one end of the cable removes environmental and electrical noise. Connect the shield wire to the source, not at the positioner.

### 6.2.3 Intrinsically Safe Barriers

When selecting an intrinsically safe barrier, make sure the barrier is HART compatible. Contact a FLOWSERVE representative to verify compatibility. Although the barrier will pass the loop current and allow normal positioner control, if not compatible, it may prevent HART communication.

### 6.2.4 Conduit

This product has three electrical conduit connections in thread size 1/2" NPT. Located near the conduit connection is the thread size for the conduit of the positioner. Conduit fittings must match equipment housing threads before installation. If threads do not match, obtain suitable adapters or contact a FLOWSERVE representative.

### 6.2.5 Grounding

The grounding terminals, located by the electrical conduit ports should be used to provide the unit with an adequate and reliable earth ground reference. Tie the outer grounding terminal to the same ground as the electrical conduit. Tie the inner grounding terminal to the cable shield.

**NOTE:** For maximum conducted immunity tie both sides of the shield to a common earth reference.

Figure 29 shows the conduit and grounding connections on the positioner.

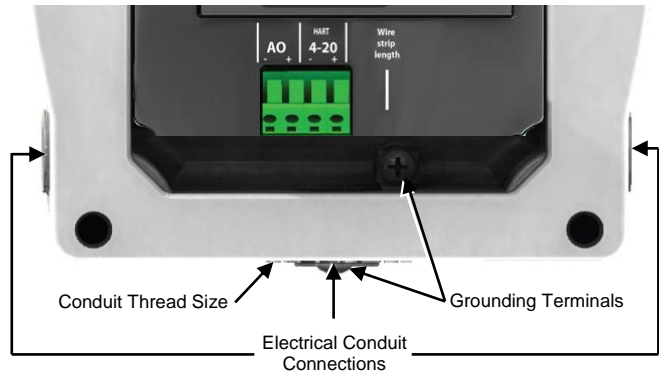

Figure 29: Conduit and Grounding (HART)

### 6.2.6 Electromagnetic Compatibility

The Logix 3820e digital positioner has been designed to operate correctly in electromagnetic (EM) fields found in typical industrial environments. Care should be taken to prevent the positioner from being used in environments with excessively high EM field strengths (greater than 10 V/m). Do not use portable EM devices such as hand-held two-way radios within 30 cm of the device.

Ensure proper wiring and shielding techniques of the control lines, and route control lines away from electromagnetic sources that may cause unwanted electrical noise. To help eliminate noise use an electromagnetic line filter; contact a FLOWSERVE representative for line filter recommendations.

In the event of a severe electrostatic discharge near the positioner, the device should be inspected to ensure correct operability. It may be necessary to recalibrate the Logix 3820e positioner to restore operation.

## 6.3 Auxiliary I/O Circuits

The Logix 3820e contains an Analog Output (AO) auxiliary circuit. The AO connection is labeled on the cover adjacent to the connection terminals.

### 6.3.1 Analog Output

The Analog Output function produces a 4-20 mA signal that corresponds to the position of the valve. Output follows actual position of the valve, including all failure modes of positioner except the loss of power. An output of < 1.0 mA is transmitted when the positioner loses power.

Calibration of the analog output signal is performed using the display menu, a HART handheld communicator, the ValveSight DTM or the LCD menu.



The AO does not interfere with positioner operation.

The AO signal corresponds with the configuration of the Signal At Closed DIP switch setting. If the valve closes with a four mA signal, the AO will show a four mA signal when closed. If the valve closes with a 20 mA signal, the AO will show a 20 mA signal when closed. This can be changed with an AO calibration.

**NOTE:** The AO has an internal fuse. In the event of a surge this fuse could be damaged and leave the AO nonfunctional.

For AO function connect AO terminals in series with a 10 to 40 VDC power supply, including a method to determine the current. The AO current will follow the valve position and will have a range of 4-20mA. See Figure 30 for more info.

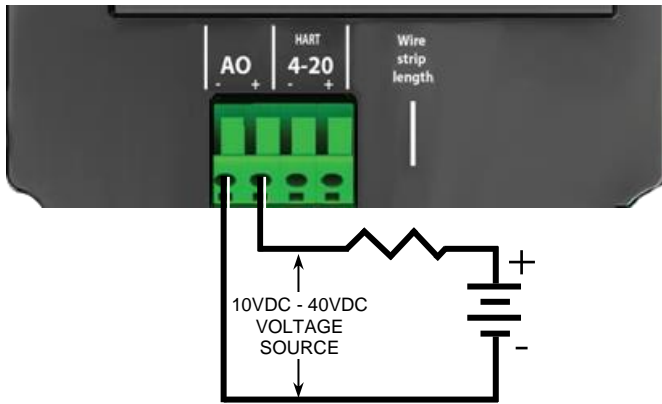

Figure 30: Analog Output Circuit

### 6.3.2 I/O Circuit Specification Summary

See Table 2: Auxiliary Circuit Status for detail on the status and condition of each circuit.

Table 2: Auxiliary Circuit Status

Circuit	Condition	Status Indication
AO	Monitoring Position (typical 4-20mA )	Output (mA)
	Less than 10 V on AO terminals.	No Loop Power

### 6.3.3 Connections for Intrinsically Safe Operation

See section 15, Hazardous Location Specifications for more information on intrinsically safe operation.

## 7 OPERATION - HOW IT WORKS

### 7.1 Basic Operation (HART)

The Logix 3820e digital positioner is a two-wire 4-20 mA input digital valve positioner which uses the HART protocol to allow two-way remote communications. The positioner is completely powered by the 4-20 mA input signal. Start-up current must be at least 3.8 mA. The positioner is configurable through the local user interface, hand-held or DTM. The Logix 3800e positioner can control both double and single-acting pneumatic actuators with linear or rotary mountings.

The Logix 3800e digital positioner is an electronic and pneumatic closed-loop feedback instrument. Figure 31 shows a schematic of the Logix 3800e.

### 7.2 Position Definition

Whether in Analog or Digital Source, the position at 0% is always defined as the valve in a closed position and 100% is always defined as the valve in an open position.

In HART Analog Source, the 4-20 mA signal is converted to a position (in percent). During loop calibration, the signals corresponding to 0% and 100% are defined.

### 7.3 Command Input and Final Command

The Command Input signal (in percent) passes through a characterization/limits modifier block. This function is done in software, which allows for in-the-field customer adjustment. The characterization block can apply no adjustment (Linear), one of several pre-defined characterization curve adjustments (including several Equal Percent), or a 21-point custom characterization curve adjustment. In Linear mode, the input signal is passed straight through to the control algorithm in a 1:1 transfer. With the pre-defined Equal Percent (=%) characterization curve, the input signal is mapped to a standard rangeability equal percent curve. If custom characterization is enabled, the input signal is mapped to a custom, user-defined 21-point output curve. The custom user-defined 21-point output curve is defined using a handheld or ValveSight software. Also, two user-defined features, soft limits and tight shutoff may affect the position. The actual command being used to position the stem after the evaluation of characterization curves and user limits is called the final command.

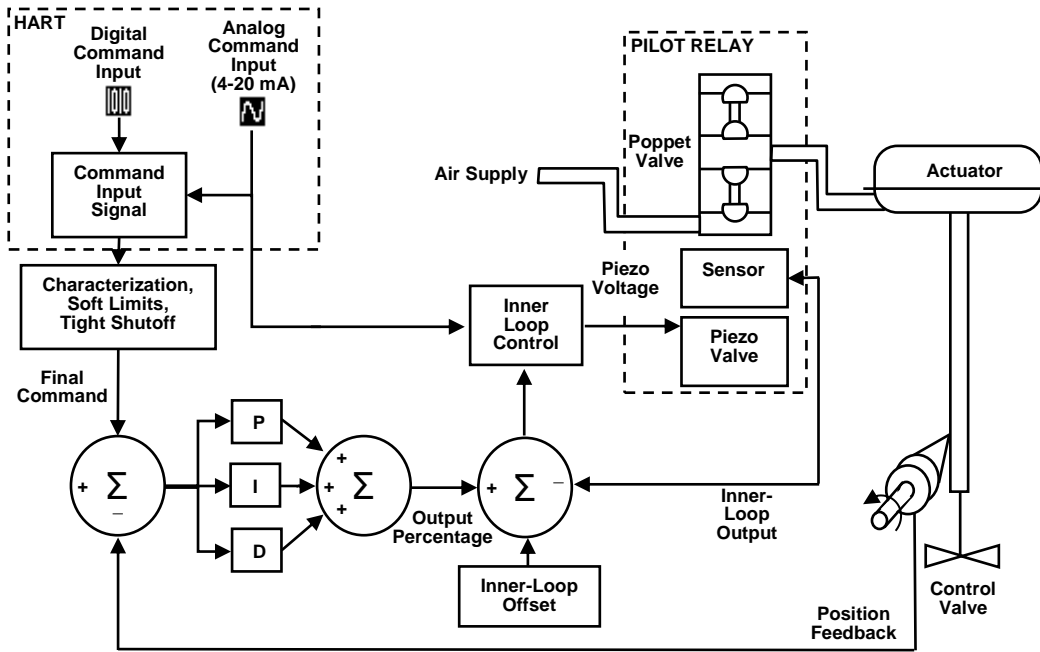

Figure 31: Principles of Operation of Logix 3800e

## 7.4 Outer Loop

The Logix 3800e uses a two-stage, stem-positioning algorithm. The two stages consist of an inner-loop (pilot relay control) and an outer-loop (stem position control). A stem position sensor provides a measurement of the stem movement. The final command is compared against the stem position. If any deviation exists, the control algorithm sends a signal to the inner-loop control to move the relay in a direction, depending upon the deviation. The inner-loop then quickly adjusts the relay poppet valve. The actuator pressures change, and the stem begins to move. The stem movement reduces the deviation between final command and stem position. This process continues until the deviation goes to zero.

## 7.5 Inner Loop

The inner-loop controls the position of the relay valve using a driver module. The driver module consists of a sensor and a Piezo valve pressure modulator. The Piezo valve pressure modulator controls the air pressure under a diaphragm using a Piezo beam bender. The Piezo beam deflects in response to an applied voltage from the inner-loop electronics. As the voltage to the Piezo valve increases, the Piezo beam bends, closing off against a nozzle causing the pressure under the diaphragm to increase. As the pressure under the diaphragm increases or decreases, the poppet valve moves up or down respectively. The sensor transmits the position of the poppet valve back to the inner-loop electronics for control purposes.

## 7.6 Detailed Sequence of Positioner Operations

A more detailed example explains the control function. Assume the unit is configured as follows:

- The unit is in Analog command source. (if using HART)
- Custom characterization is disabled (therefore characterization is Linear).
- No soft limits enabled. No final value cutoff set.
- Valve has zero deviation with a present input signal of 50%
- Loop calibration (if using HART): 4 mA = 0% command, 20 mA = 100% command.
- The actuator is tubed and positioner is configured air-to-open.

Given an input command of 50%, since custom characterization is disabled, the command source is passed 1:1 to the final command. Since zero deviation exists, the stem position is also at 50%. With the stem at the desired position, the relay will be at a middle position that balances the pressures above and below the piston in the actuator. This is commonly called the null position.

Assume the input signal changes from 50% to 75%. The positioner sees this as a command source of 75%. With linear characterization, the final command becomes 75%. Deviation

is the difference between final command and Stem Position: Deviation = 75% - 50% = +25%, where 50% is the present stem position. With this positive deviation, the control algorithm sends a signal to move the poppet up from its present position. As the relay moves, the supply air is applied to the bottom of the actuator, and the air is exhausted from the top of the actuator. This new pressure differential causes the stem to start moving towards the desired position of 75%. As the stem moves, the Deviation begins to decrease. The control algorithm begins to reduce the poppet opening. This process continues until the Deviation goes to zero. At this point, the relay will be back in its null or balanced position. The desired stem position is achieved when the stem movement stops.

## 7.7 Inner Loop Offset

The position of the poppet at which the pressures are balanced, holding the valve position in a steady state, is called the inner loop offset. The controlling algorithm uses this value as a reference in determining the piezo voltage. This parameter is important for proper control and is optimized and set automatically during stroke calibration.

## 8 OPERATION – DIP SWITCH CONFIGURATION

The Logix 3800e local user interface allows the user to calibrate, configure the basic operation, and tune the response of the positioner without additional tools or configurators.

Before placing the unit in service set the DIP Switches to the desired control options. The DIP Switch settings do not take effect immediately, but are activated only by performing a Stroke calibration (pressing the “QUICK-CAL” button for 3 seconds). However, the DIP switch settings may be edited from the DTM or Handheld at any time. See Figure 32: Local User Interface.



Figure 32: Local User Interface

### 8.1 Air Action Switch (ATO ◀▶ ATC)

The air action switch must be set to match the configuration of the valve/actuator mechanical tubing connection. The tubing determines the air action of the system.

ATO – Increasing pressure from Port A causes the valve to open.

ATC – Increasing pressure from Port A causes the valve to close.

### 8.2 Actuator Switch (DOUBLE ◀▶ SINGLE)

The actuator switch must be set to match the configuration of the actuator. The diagnostics and control depend on the accurate selection of this switch. .

Double – When there is pressure on both sides of the actuator Select Double.

Single – When there is pressure on only one side of the actuator select Single.

### 8.3 Characterization Switch (LINEAR ◀▶ OTHER)

The Characterization Switch allows a better match between the input command and the actual fluid flow through the valve. The positioner makes a correction by applying an adjustment to the input command according to a characterization curve. Usually, valves that have non-linear flow characteristics require a characterization curve to be specified.

Linear – Select Linear if the actuator position should be directly proportional to the command input signal. (For most rotary valves, this setting gives an =% Cv characteristic due to their inherent =% characteristics.)

Other – To select one of the pre-set characterization curves or a custom curve choose Other. The default is the Linear Characterization. Other custom curves such as a standard 30:1 equal percent range ability curves are available in the diagnostic tools. To select one of the other curve options, use the LCD menu, a Handheld or the ValveSight DTM. To modify the Custom curve, use the DTM.

### 8.4 Auto-Tune Switch (TUNE ON ◀▶ TUNE OFF)

This switch controls whether the positioner will automatically tune itself during the stroke calibration (Quick-Cal), or use preset tuning parameters. On is recommended in most cases.

On – Selecting On enables an auto tune feature that will automatically determine the positioner gain settings. Response parameters measured during the latest Quick-Cal determine the automatic tuning. The valve response is a combination of these response parameters and the current position of the Selectable GAIN Switch.

Off – Selecting Off forces the positioner to use one of the factory preset tuning sets determined by the Selectable GAIN Switch. Settings “B” through “J” are progressively higher predefined tuning sets.

Selecting “A” on the Selectable Gain Switch during a Quick-Cal allows the user to use and preserve manually adjusted gains. The calibration only sets the position limits in this case. See section 9, Operation – Calibration And Control9, for more details.

**NOTE:** The gain switch is LIVE meaning that regardless of the Auto-Tune selection, the gain settings can be adjusted at any time during operation by changing the selectable Gain switch position. See Figure 33: Selectable Gain Switch.

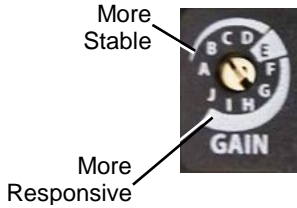

Figure 33: Selectable Gain Switch

### 8.5 Jog Calibration Switch (CAL AUTO ◀▶ CAL JOG)

This switch selects between Auto and Jog calibration modes.

Auto – The Auto setting works for most valves if the fully opened position of the valve has a mechanical stop. In Auto mode during a stroke calibration (Quick-Cal), the positioner will fully close the valve and register the 0% position, then fully open the valve to register the 100% position.

Jog – Use the Jog setting if the fully opened position of the valve has no hard stop and is manually set. In Jog mode during a stroke calibration (Quick-Cal), the positioner will fully close the valve and register the 0% position, then wait for the user to move the valve to the 100% open position using the Up and Down buttons. Press the ACCEPT/QUICK-CAL button to accept the 100% location.

See section 9, Operations – Calibration and Control, for more information.

### 8.6 Valve Stability Switch (LO FRIC ◀▶ HI FRIC)

This switch adjusts the position control algorithm of the positioner for use with low-friction control valves or high-friction automated valves.

Lo Friction – Placing the switch to Lo Friction optimizes the response for low friction, high-performance control valves. This setting provides for optimum response times when used with most low friction control valves.

Hi Friction – Placing the switch to the right optimizes the response for valves and actuators with high friction levels. This setting slightly slows the response and will normally stop limit cycling that can occur on high friction valves.

### 8.7 Signal at Closed Switch (HART) (4mA ◀▶ 20mA)

Normally this will be set to 4 mA for an Air-To-Open actuator configuration, and 20 mA for Air-To-Close.

4 mA – Selecting 4 mA will make the valve close when the signal is low (4 mA) and open when the signal is high (20 mA).

20 mA – Selecting 20 mA will make the valve close when the signal is high (20 mA) and open when the signal is low (4 mA).

**NOTE:** When using an Analog Output (AO) function, the AO signal corresponds with the Signal At Closed selection. If the valve closes with a 4 mA signal, the AO will show a 4 mA signal at closed. If the valve closes with a 20 mA signal, the AO will show a 20 mA signal at closed.

### 8.8 HART Switch (HART) (HART 6 ◀▶ HART 7)

For HART 6 protocol, select HART6. For HART 7, select HART 7.

## 9 OPERATION – CALIBRATION AND CONTROL

### 9.1 Quick-Cal Calibration

The QUICK-CAL  button is used to initiate an automatic stroke calibration. This stroke calibration determines the closed (0%) and open (100%) positions of the valve and gathers information about the response of the valve to determine the gains. The gains are automatically set. After a stroke calibration, the positioner is ready to control.

To perform a QUICK-CAL, press and hold the QUICK-CAL  button for approximately 3 seconds.

While the automatic calibration is in progress, the LED lights will flash Y-R-Y-G (yellow-red-yellow-green) status codes indicating the calibration progress.



## 9.2 Jog Calibration

If the valve/actuator assembly has **no** internal mechanical stop at the fully open position, set the Jog Calibration Switch (DIP 5) to Cal Jog. In this case, press and hold the QUICK-CAL button for approximately 3 seconds.

This process initiates the jog stroke calibration. The positioner will then close the valve and set the zero position. The zero position is automatically always set at the valve seat. At this point, the LED's will flash in a sequence of Y-R-Y-G (yellow-red-yellow-green) which indicates that the user must use the jog keys to position the valve to approximately 100% manually.

## 9.3 Tuning Options

Use the Selectable GAIN Switch to adjust the gain at any time during operation. This adjustment takes effect immediately. For faster response select settings above "E" (F-J). For a more stable response, select settings below "E" (B-D). See Figure 33: Selectable Gain Switch.

Quick-Cal Custom Gains – This is typically the fastest way to achieve ideal gains. Set the Auto-Tune Configuration Switch to "On" and the Selectable GAIN Switch to "E." Then perform a Quick-Cal. During the Quick-Cal, custom tuning parameters will be determined based on measured response parameters. Fine tune the gains by adjusting the Selectable GAIN Switch. Selecting "D" "C" or "B" will progressively provide a more stable response. Selecting "F" through "J" will progressively provide a more active response. In most cases selecting "E" will give the best results and is the default setting for all actuator sizes. Raising or lowering the Selectable Gain Switch setting is a function of the positioner/valve response to the control signal, and is not actuator size dependent.

Standard Preset Gains – If standard, preset gains are desired, set the Auto-Tune Configuration Switch to Off. After performing a Quick-Cal, use the Selectable GAIN switch to the desired level ("B" – "J"). The standard, preset gain settings are not affected by Quick-Cal.

It may be necessary to set the gain switch BEFORE the Quick Cal. Very fast stroking valves may need to be at lower gains and very slow stroking valves may need to be at higher gains.

Custom Manual Gains – To set gains manually, set the selectable GAIN switch to "A." Changing the switch from "B" to "A" will write the standard "B" settings into the "A" parameters, allowing a starting point for modification. Similarly, changing the switch from "J" to "A" will write the standard "J" settings into the "A" parameters. Custom tuning values can then be entered using the Display Menu, a Handheld or ValveSight DTM. With the Selectable GAIN Switch set to "A," the tuning will not be modified during a Quick-Cal.

## 9.4 Factory Reset

To perform a factory reset, hold the QUICK-CAL button while applying power. Factory reset causes a reset of all the internal variables to factory defaults, including calibration. The

Use the button and button to position the valve at approximately 100% open.

Press the ACCEPT/QUICK-CAL button to proceed. Once complete, there are no more required user actions during calibration. The calibration is complete when the lights return to a sequence that starts with a green light.

The jog calibration process will only allow the user to set the span. If an elevated zero is needed, a handheld or ValveSight DTM are required.

positioner must be re-calibrated after a factory reset. Restore tag names and other user configured limits, alarm settings, and valve information.

**NOTE:** For HART position, a factory reset will always reset the command source to analog 4-20 mA.

**CAUTION:** Performing a factory reset may result in the inability to operate the valve until properly reconfigured. Notify proper personnel that the valve may stroke, and make sure the valve is properly isolated.

# 10 OPERATION – USER INTERFACE

## 10.1 LCD

The optional LCD provides a variety of useful information and functions. The Main View shows important information using icons and scrolling status lines. See Figure 34 for more detail. For display information related to fieldbus see the Logix 3800e FF Reference Guide, LGENIM3840.

Use the directional buttons to navigate from the Main View to the LCD menu. This menu provides detailed information and allows the user to perform common functions.

**NOTE:** The LCD backlight may change brightness during use and is normal. The backlight uses any residual power not used by other functions of the circuitry. When current supply is low (4mA) the screen will appear darker. When current supply is high (20mA) the screen will appear brighter. Also note, the LCD may not be readable at temperatures below -20°C (-4°F) and temperatures above 70°C (158°F).

The main view provides an instant display of important status parameters: Position, Final Command, Scrolling Status Message, Current Alarm Status and Status Icons.

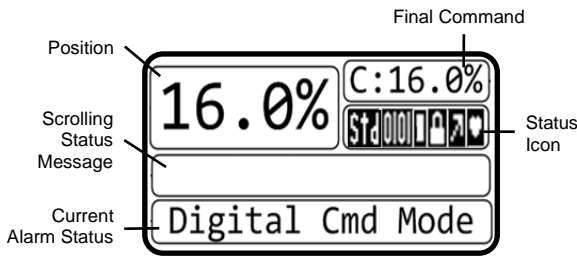

Figure 34: Display Main View

### 10.1.1 Position and Final Command

Shown always are the current Position and Final Command. The Final Command is the command adjusted according to a Characterization Curve, Tight Shut Off, or Soft Limits that have been applied. Final Command should match the Position.

### 10.1.2 Scrolling Status Messages

The Scrolling Status Message provides the following information as applicable:

Date and Time – The date and time format is adjustable.

Ambient Temperature – This is the temperature inside the positioner.

DIP Switch Override – This indicates that the Configuration (DIP) Switches do not reflect the actual configuration of the positioner. Changing a Configuration Switch after a Quick-Cal, or if the configuration is changed from the DTM will cause a Dip Switch Override. Performing a Quick-Cal will reset the configuration to what the Configuration Switches show, which may not be desirable in this case. Ensure the Configuration Switches are set properly before performing a Quick-Cal.

**NOTE:** *The Scrolling Status Message function is disabled by default. Activate Scrolling Status Messages through the display menu.*

### 10.1.3 Current Alarm Status

The Current Alarm Status area shows the highest priority alarm, warning, alert or status indication. This matches the code indicated by the flashing LEDs.

### 10.1.4 Status Icons

Status icons continuously show the state of the features and modes. See Table 3: Status Icons for more details.

Command Source Icons – The positioner is in Analog Command mode if it is using the 4-20 mA signal to control the location of the valve. In Digital Command mode, a HART

positioner ignores the 4-20 command and responds to the position command given through HART. In Out Of Service mode, the positioner is performing a calibration, signature, partial stroke test, is in a factory reset state, or another off-line mode.

Communications Icons – When the positioner is sending or receiving data via the HART communication protocol, the heart icon will be displayed. During burst mode, a pulsating heart icon will be displayed.

Table 3: Status Icons

Icon Location	Icon	Icon Meaning
Licensing		Standard
Command Source		Analog command mode
		Digital command mode
		Out of service
	(blank)	Pressure control not locked
Communications		HART communication currently in progress
		HART Burst mode in progress
	(blank)	No communication currently in progress

10

## 10.2 LCD Menu Features

To enter the menu briefly press or button. A menu tree can be found in Appendix A – Lcd Menu Tree Overview. Menu features are fully described in Appendix B – Lcd Menu Tree Descriptions.

## 10.3 LEDs and Status Codes

LEDs give two types of status codes. The first type is a single color NAMUR status. The second type is a 4-blink status that correlates to a specific positioner error or condition. Regardless of the type of code (1 blink or 4), the LEDs always indicate a code corresponding to the highest priority alarm, warning, alert or status that is currently active.



### 10.3.1 Single Blink NAMUR Color Codes

If buttons on the positioner have not been pressed recently, the positioner will blink one color. This color represents one of the 5 conditions outlined in the NAMUR standard, NE-107. These are listed in Table 4: NE 107 Status Code. How these colors are assigned to specific conditions can be customized in the DTM.

**Table 4: NE 107 Status Code**

Single Blink Color	NE 107 Indication
	Diagnostics active – No issues
	Maintenance
	Out of specification
G	Check function
B	Failure

O  
R

### 10.3.2 4-Blink Status Codes

When a button is pressed on the positioner, the color code will expand to a 4-color sequence. This corresponds to one of the specific status indications listed in Appendix D – 4-Blink Status Codes. When multiple codes are active, only the highest priority condition is represented by the blink code. To see all of the active alarms and status conditions, use a DD or DTM.

## 10.4 Tamper Lock

In order to prevent unintentional adjustments of the configuration, tuning, or control of the valve, the Tamper Lock feature may be used. This is set in the DTM and disables the buttons and menus except for the ability to view the status of the positioner. When locked, the positioner may be temporarily unlocked by entering a PIN. The PIN may be entered using LCD. The tamper lock feature can also be disabled in the DTM.

## 10.5 Hot Keys

Hot keys are button combinations used to quickly access different features. They are available to press when the LCD screen is showing the Main view. See Table 5: Hot Keys. or for more detailed instruction, see Appendix F – Hot Keys.

**Table 5: Hot Keys**

	I	II	III	From Dashboard
Brief Button Press				Navigate Menu
				Continue in Menu
				Navigate Menu
				Abort Calibration
3 Sec Press				Quick-Cal*
				Command Reset (HART)
				PST
				View Code Version
				Adjust LCD Screen Contrast
				Local Valve Control
				I/O Calibrations (HART)
6 Sec Press				Low Level Calibration Functions
Seq. Press				Clear PST fail error message (Hold III for 3 Sec, then brief press II)

## 10.6 Viewing Version Numbers (No LCD)

The firmware version numbers may be checked at any time except during a calibration. To see the version number, hold the and the buttons for 3 seconds. Then briefly press the button to see the major version and the button for minor version number. The codes are in a 3-blink sequence. The sequence corresponds to a number as shown in Table 6: Version Number Codes.

To exit the version viewing mode, briefly press the button. This will not alter the operation of the positioner.

**Table 6: Version Number Codes**

1 <sup>st</sup> Blink Color	2 <sup>nd</sup> Blink Color	3 <sup>rd</sup> Blink Color	Version Number
			0
			1
G	G	G	2
G	G	B	3
G	G	Y	4
G	G	O	5
G	B	G	6
G	B	B	7
G	B	Y	8
G	B	O	9
G	Y	G	10
G	Y	B	11
G	Y	Y	12
G	Y	O	13
G	O	G	14
G	O	B	15
G	O	Y	16
G	O	O	17
G	R	G	18
G	R	B	19
G	R	Y	20
G	R	O	21
B	G	G	22
			23
			24
			25

## 11 MAINTENANCE – TROUBLESHOOTING

Below are some common solutions related to commissioning.  
For additional help with errors, refer to Appendix D – 4-Blink Status Codes.

### 11.1 Troubleshooting Guide (HART)

**Table 7: Troubleshooting Guide (HART)**

Failure	Probable Cause	Corrective Action
No LED is blinking.	<ol style="list-style-type: none"> <li>1. Current source too low.</li> <li>2. The current source voltage is too low.</li> </ol>	<ol style="list-style-type: none"> <li>1. Verify current source supplies at least 3.8 mA.</li> <li>2. Verify voltage source supplies at least 10VDC at terminals of device.</li> </ol>
Erratic communications.	<ol style="list-style-type: none"> <li>1. Current source bandwidth is not limited to 25Hz.</li> <li>2. Maximum cable length or cable impedance exceeded.</li> <li>3. HART modem not receiving enough power.</li> <li>4. Interference with I.S. barrier.</li> <li>5. The current source is stripping (filtering) HART signal.</li> </ol>	<ol style="list-style-type: none"> <li>1. Maximum allowable current source rate of change is 924 mA per second.</li> <li>2. Check cable size, length and capacitance.</li> <li>3. Verify laptop battery is not low.</li> <li>4. Must use HART compatible I.S. barrier.</li> <li>5. Use a 250Ω resistor and a 22 μF capacitor to create a HART filter according to the following schematic.</li> </ol>
The unit does not respond to analog commands.	<ol style="list-style-type: none"> <li>1. The positioner is in digital command mode.</li> <li>2. An error occurred during calibration.</li> </ol>	<ol style="list-style-type: none"> <li>1. Switch to analog command mode using the one of the following procedures. <ol style="list-style-type: none"> <li>a. Valve Sight DTM</li> <li>b. Handheld communicator</li> <li>c. Hot key – Hold  for 3 seconds</li> </ol> </li> <li>2. Check Status Codes. Correct calibration error. Recalibrate.</li> </ol>
Valve position reading is not accurate.	<ol style="list-style-type: none"> <li>1. Stroke not calibrated.</li> <li>2. Tight shutoff is active.</li> <li>3. Custom characterization or soft stops are active.</li> </ol>	<ol style="list-style-type: none"> <li>1. Perform a Stroke calibration (Quick-Cal).</li> <li>2. Verify Tight Shutoff settings.</li> <li>3. Verify custom characterization or soft-stop limits.</li> </ol>
The position is driven fully open or closed and will not respond to the command.	<ol style="list-style-type: none"> <li>1. Bad stroke calibration.</li> <li>2. The relay sensor or magnet is not connected.</li> <li>3. Selected the wrong air action in the software.</li> <li>4. Actuator tubing is backward.</li> <li>5. The relay or piezo is malfunctioning.</li> <li>6. Control parameter inner-loop offset is too high/low.</li> </ol>	<ol style="list-style-type: none"> <li>1. Perform stroke calibration (Quick-Cal)</li> <li>2. Verify hardware connections.</li> <li>3. Check ATO (Air-to-open) and ATC (Air-to-Close) settings. Recalibrate using Quick-Cal to apply settings.</li> <li>4. Verify ATO/ATC actuator tubing.</li> <li>5. Replace the relay or piezo.</li> <li>6. Perform stroke calibration (Quick-Cal).</li> </ol>

Failure	Probable Cause	Corrective Action
Sticking or hunting operation of the positioner	<ol style="list-style-type: none"> <li>1. Contamination of the electro-pneumatic converter.</li> <li>2. Control tuning parameters not correct.</li> <li>3. Packing friction is high.</li> <li>4. Improper sizing of Valve/Actuator for process conditions.</li> </ol>	<ol style="list-style-type: none"> <li>1. Check air supply for proper filtering and meeting ISA specifications ISA-7.0.01.</li> <li>2. Lower proportional gain settings. Use the Gain switch.</li> <li>3. Change the stability DIP switch to “HI FRIC” on the local interface and recalibrate. If the problem persists, adjust pressure control window with handheld communicator or ValveSight and recalibrate.</li> <li>4. Verify the Valve and Actuator are sized properly for operating conditions.</li> </ol>
LCD backlight is flickering or dim.	<ol style="list-style-type: none"> <li>1. The backlight uses any residual power not used by other functions of the circuitry.</li> </ol>	<ol style="list-style-type: none"> <li>1. Fluctuations in the LCD backlight are normal. No action required.</li> </ol>

## 12 MAINTENANCE - REPAIR

### 12.1 Training and Precautions

The replacement of the kits listed in section 14, Positioner Specifications, must be by a technician trained in positioner function and handling of static sensitive devices. Remove from hazardous area prior to working through any maintenance procedures.

**CAUTION:** Use eye protection when servicing.

**CAUTION:** Depressurize the positioner before servicing.

**CAUTION:** When touching the circuit boards, observe precautions for handling electrostatically sensitive devices.

### 12.2 Cleaning

With the cover in place and with cover bolts torqued to spec, the positioner may be cleaned by spraying with water. The positioner may be wiped with a soft cloth. Do not use abrasive materials, detergents, or chemicals.

### 12.3 Scheduled Maintenance

The supply gas filter(s) should be scheduled for regular maintenance as required to maintain supply gas quality. Any contamination found in the filter, requires visual inspection inside of the positioner for contamination. Any contamination found in the positioner, requires replacement of the positioner.

### 12.4 Required Tools and Equipment

The Logix 3800e digital positioner has modular components that can be replaced using the tools shown in Figure 35.





- Philips Screwdriver #2 
- 6.0 mm Hex Key 
- 5.0 mm Hex Key 
- 2.5 mm Hex Key 

Figure 35: Tools List

### 12.5 Torque Specification for Screws

Table 8: Torque Specification shows the Logix 3800e torque specifications. Torque all screws to the proper specification to avoid damaging components or loosening of the screws during use.

Table 8: Torque Specification

Screw or Bolt	Type	Torque
Outer Cover – EX and SS (6 Bolts)	6 mm Hex	5.6 N-m (50 in-lb)
Outer Cover – IS (4 Bolts)	Phillips	1.7 N-m (15 in-lb)
Manifold (4 Bolts)	5 mm Hex	2.8 N-m (25 in-lb)
Inner Cover (2 Screws)	2.5 mm Hex	2.0 N-m (18 in-lb)
Electronic Assembly (5 Screws)	Phillips	0.9 N-m (8 in-lb)
Feedback Shaft Cover (3 screws)	Phillips	0.9 N-m (8 in-lb)

## 12.6 Replacing the Electronics

Refer to Figure 36: Piezo Installation and Figure 37: Replacing the Electronics.

### Removal:

- 1 Make sure the valve is bypassed or in a safe condition.
- 2 Disconnect power to the positioner.
- 3 Disconnect air supply to the positioner.
- 4 Remove the inner cover by removing the two PCB cover retaining screws.
- 5 Unscrew the five electronics module retaining screws.
- 6 Gently remove the electronics by holding the terminal block and lifting the electronics from the housing.

### Installation:

- 1 Verify that the 4 pressure sensor O-rings are in the electronics assembly.
- 2 Verify that the piezo O-rings are placed in the Housing.
- 3 Verify that the piezo is plugged into the bottom of the electronics assembly.
- 4 Place the electronics assembly into the housing, aligning the pressure sensor O-rings with the four holes in the housing.
- 5 Tighten the 5 electronics assembly screws down, in a star-shaped pattern, to verify even pressure for sealing the O-rings.
- 6 Torque screws to 0.9 N-m (8 in-lb).
- 7 Place inner cover over electronics assembly and tighten screws in a back and forth pattern to verify even pressure.
- 8 Torque screws to 0.9 N-m (8 in-lb).
- 9 Reconnect the valve, mounting, power, and air supply as directed by this manual.
- 10 Recalibrate as directed by this manual.

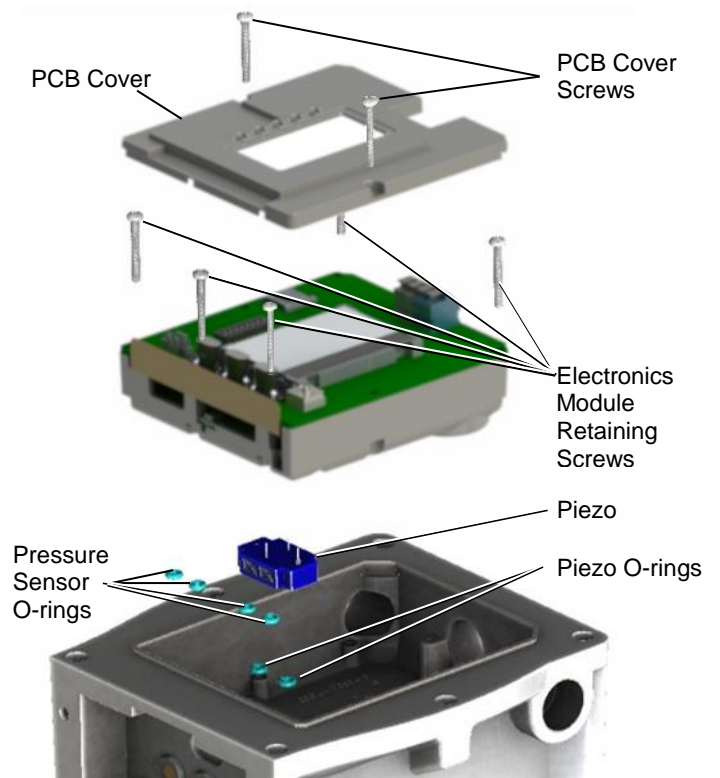

Figure 37: Replacing the Electronics

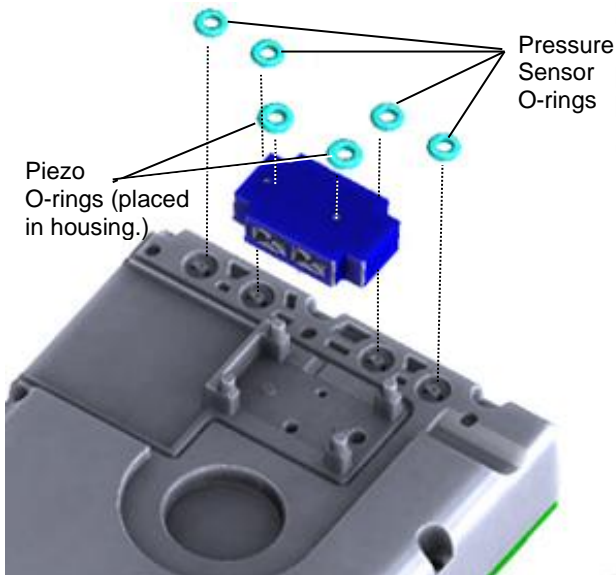

Figure 36: Piezo Installation



## 12.7 Replacing the Relay

Refer to **Error! Reference source not found..**

### Removal:

- 1 Make sure the valve is bypassed or in a safe condition.
- 2 Disconnect power and conduit to the positioner.
- 3 Disconnect air supply and actuator tubing to the positioner.
- 4 Remove the manifold bolts (using 5.0mm Hex Key).
- 5 Remove the manifold.
- 6 Discard the 5 manifold O-rings.

### Installation:

- 1 Tip the housing so that the Manifold interface is facing up (so the O-rings don't fall).
- 2 Place the five new O-rings shipped in the kit in the housing.
- 3 Place the Manifold/Relay assembly onto the housing.
- 4 Tighten the 4 bolts in a star pattern to ensure even pressure.
- 5 Torque the bolts to 2.8 N-m (25 in-lb).
- 6 Readjust the positioner to the correct orientation and tighten the mounting bolts.
- 7 Reconnect power, and air supply as directed by this manual.
- 8 Recalibrate as directed by this manual.

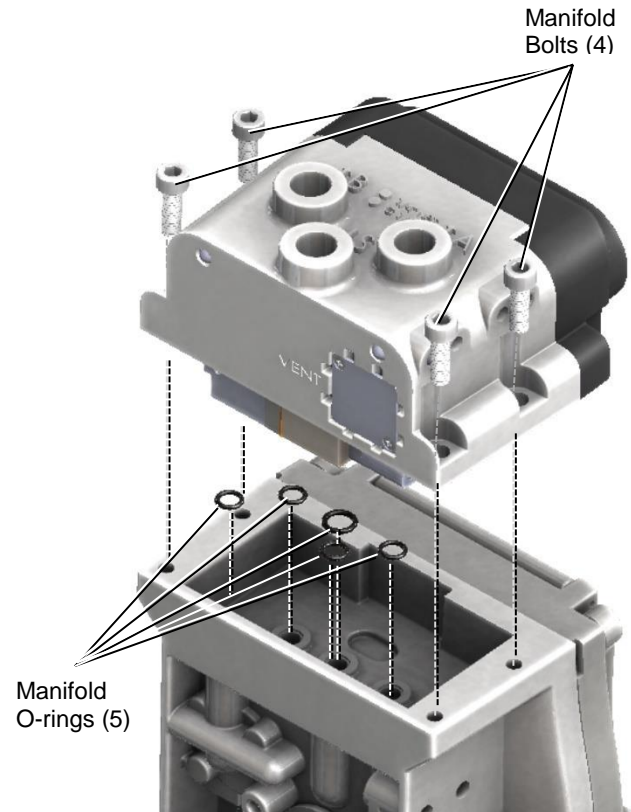

**Figure 38: Replacing the Relay**

## 12.8 Replacing the Shaft Assembly

Refer to Figure 39: Replacing the Feedback Mechanism

### Removal:

1. Make sure the valve is bypassed or in a safe condition.
2. Disconnect power and conduit to the positioner.
3. Disconnect air supply and actuator tubing to the positioner.
4. Unmount the positioner from actuator and disengage the feedback mechanism from the follower arm assembly.
5. Place the positioner facedown so that the feedback shaft is pointing up and use a Phillips Screwdriver #2 to remove the three feedback screws.
6. Discard the feedback mechanism and screws

### Installation:

1. Apply 3M Scotch-Weld Threadlocker TL22 or Loctite 243 to the three holes on the back of the positioner housing
2. Insert and align the new feedback mechanism assembly with the back of the housing.
3. Using a Phillips Screwdriver #2, torque the three screws to 0.9 N-m (8 in-lb)
4. Adjust the positioner to the correct mounting orientation, connect the feedback mechanism to the follower arm assembly. It is recommended to connect the feedback mechanism and follower arm in a position where the feedback spring is engaged; not on a feedback shaft rotational stop. Finish mounting the positioner.
5. Reconnect power, and air supply as directed by this manual.
6. Perform a Stroke Calibration as directed by this manual

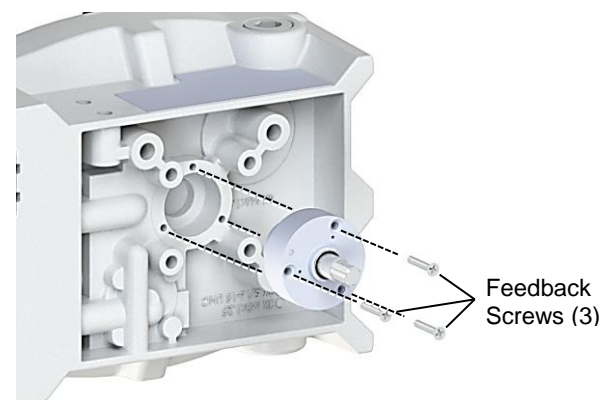

**Figure 39: Replacing the Feedback Mechanism**

## 12.9 Ordering Spare Parts

For spare part kits and part numbers, see Appendix G - How To Order.

## 12.10 Disposal

Although the Logix 3800e is not within the scope of the Waste Electronics and Electrical Equipment (WEEE) Directive 2012/19/EU, disposal of this product should be handled by a specialized recycling facility; not by municipal waste collection services. Proper disposal is essential to the protection of the environment and community. If proper disposal is not possible, the positioner may be returned to Flowserve for disposal. Call your local sales representative for more information regarding Flowserve's disposal process and associated fee.

If the cause of the unit failure is found to be a manufacturing defect and the unit is within the warranty period it will be repaired free of charge. There is a fee for the evaluation in the event there is no problem found with the unit, and the unit is still under warranty. A fee will be charged for the evaluation if the warranty does not cover the cause of the unit failure. A quote will be provided showing the cost of the repair. Waiving of the fee requires the customer to purchase a new positioner.

# 13 MAINTENANCE - HELP FROM FLOWSERVE

## 13.1 Phone Support

Over-the-phone troubleshooting is available for positioner issues. Should your positioner be experiencing problems, or if you have questions that are not answered by this manual, feel free to call your local sales representative or a Quick Response Center (QRC).

Contact your nearest FLOWSERVE sales representative.  
 Europe +43 (0) 4242 41181 999  
 North America +1 801 489-2300  
 Asia + (65) 6879 8900  
[digitalproductstac@flowserve.com](mailto:digitalproductstac@flowserve.com)

See the back cover of this manual for additional contact details.

## 13.2 Returning the Logix 3800e Positioner for Service

Returning the unit is an option if troubleshooting is unable to solve the problem. Please follow the steps below.

1. Request a Return Materials Authorization (RMA) form. The form should arrive in an email.
2. Remove all fittings, brackets, filters, feedback arms, etc. from the unit before packaging.
3. When operating the unit with a gas other than clean air requires the related MSDS with the unit.
4. Complete the RMA form. Write any particular issues with the positioner you would like us to evaluate. Please include the customer name and contact information.
5. When packaging, please secure the unit in a method that will ensure it will reach our facility undamaged (the weight of positioners will often settle through packing peanuts and pop large air pockets).
6. Please insert a copy of the completed RMA form inside the package and write the RMA number on the outside of the package. Send the unit to the address at the bottom of the form.

## 14 POSITIONER SPECIFICATIONS

### 14.1 Input Signal

**Table 9: Input Signal (HART)**

Power Supply	Two-wire, 4-20 mA 10.0 VDC plus line losses
Input Signal Range	4 - 20 mA
Compliance Voltage	10 to 32 VDC @ 20 mA
Effective Resistance	500 Ω @ 20 mA Typical
Minimum Required Operating Current	4.0 mA
Maximum Shutdown Current	3.6 mA
Power Interruption Time Limit	After applying power for at least 1 minute, a 40 ms power interruption will not cause the positioner to reset.
Power-up time	Time from the application of power to begin controlling valve < 1.0 second.
Communications	HART protocol (Logix 382Xe) No COMM (Logix 381Xe)
Wire	Spring Terminal 24-16 AWG
Cable	Refer to the HART Field Communications Protocol Application Guide, HART HCF LIT

### 14.2 Pneumatic Output

**Table 10: Pneumatic Output**

Output Pressure Range	0 to 100% of air supply pressure.
Output Air Capacity	14.3 Nm <sup>3</sup> /h @ 1.5 bar (8.44 SCFM @ 22 PSI)
	30.6 Nm <sup>3</sup> /h* @ 4.1 bar (17.5 SCFM* @ 60 PSI) (C <sub>v</sub> 0.47)
Output Air Capacity Single Acting Relay	6.85 Nm <sup>3</sup> /h @ 1.5 bar (4.27 SCFM @ 22 PSI)
	15.3 Nm <sup>3</sup> /h @ 4.1 bar (9.50 SCFM @ 60 PSI) (C <sub>v</sub> 0.257)
Primary Output Ports (Pressurized port is in energized state. Port is exhausted upon loss of power.)	Port A
<small>*Port screen filters may reduce the output air capacity to 22.4 Nm<sup>3</sup>/h @ 4.1 bar (12.8 SCFM @ 60 PSI C<sub>v</sub> 0.35). Removal of the filters may be required to obtain maximum air capacity.</small>	

### 14.3 Air Supply

**Table 11: Air Supply**

Minimum Input Pressure	1.5 Bar (22 PSI)
Maximum Input Pressure	10.3 Bar (150 PSI)
Air Supply Quality	The air supply must be free from moisture, oil, and dust by conforming to the ISA 7.0.01 standard. (A dew point at least 18° F below ambient temperature, particle size below five microns, and oil content not to exceed one part per million).
Operating Humidity	0 - 100% non-condensing
Acceptable Supply Gasses	Air, sweet natural gas, nitrogen, and CO <sub>2</sub> are acceptable supply gasses. Sour natural gas is not acceptable. For Type nA and Type tb installation, only connect air or inert gas to the air supply inlet.
Air Consumption Double Acting Relay	0.297 Nm <sup>3</sup> /h @ 1.5 bar (0.175 SCFM @ 22 PSI)
	0.637 Nm <sup>3</sup> /h @ 4.1 bar (0.300 SCFM @ 60 PSI) (C <sub>v</sub> 0.008)
Air Consumption Single Acting Relay	0.178 Nm <sup>3</sup> /h @ 1.5 bar (0.111 SCFM @ 22 PSI)
	0.275 Nm <sup>3</sup> /h @ 4.1 bar (0.171 SCFM @ 60 PSI) (C <sub>v</sub> 0.005)
Air Consumption Double Acting Low Bleed Relay	0.075 SCFM @ 60 PSI (C <sub>v</sub> 0.002)

### 14.4 Analog Output (HART)

**Table 12: 4 to 20 mA Analog Output Specification**

Power Supply Range	10.0 to 40 VDC, (24 VDC Typical)
Current Signal Output	4 to 20 mA
Linearity	1.25% F.S.
Repeatability	0.25% F.S.
Hysteresis	1.0% F.S.
Operating Temperature	-55 to 85°C (-67 to 185°F)

### 14.5 Stroke Output

**Table 13: Stroke Output**

Feedback shaft Rotation	Min 15°, Max 110° (with spring bias) Max 180° (without spring bias) 60° recommended for linear applications.
-------------------------	--

## 14.6 Positioner Performance Characteristics

**Table 14: Performance Characteristics**

Better than or equal to the following values on a 25 square inch Mark I actuator.	
Resolution	≤ 0.25%
Linearity	+/-1.25%
Repeatability	≤ 0.25%
Hysteresis	≤ 1.0%
Deadband	≤ 0.3%
Sensitivity	≤ 0.25%
Stability	≤ 0.4%
Long term drift	≤ 0.5%
Supply Pressure Effect	≤ 0.2% per 10 psi (0.69 bar)

**NOTE:** Performance tested according to ISA 75.13.

## 14.7 Temperature

**Table 15: Temperature**

Operating Temperature Range	-40 to 70°C (-67 to 158°F)
Transport and Storage Range	-40 to 70°C (-67 to 158°F)

**NOTE:** Reduced performance possible at low temperatures. LCD may not be readable at temperatures below -20°C (-4°F) and temperatures above 70°C (158°F).

## 14.8 Physical Specifications

**Table 16: Physical Specifications**

Housing Material	Cast, powder-painted Copper-free aluminum (EN AC-43400/EN AC-ALSi10Mg(Fe))
Soft Goods	Fluorosilicone / Fluorocarbon / Buna-N
Weight of Base Positioner Without Accessories	4 kg (8.8 lbs.) – Aluminum

## 14.9 ValveSight DTM Software Specifications

**Table 17: ValveSight DTM Software Specifications**

Computer	Minimum Pentium processor running Windows 2000, XP, Server 2003, Server 2003 R2, Server 2008 (32-bit & 64-bit Versions), Server 2008 R2 (32-bit & 64-bit Versions), and 7 (32-bit & 64-bit Versions). Memory: >64MB Available HARD Disk Space : >64MB
Ports	One minimum available with eight maximum possible. (Can also communicate via serial, and USB connections)
HART Filter	Often required in conjunction with some DCS hardware.

**14.10 Positioner Dimensions - Explosion Proof Housing**

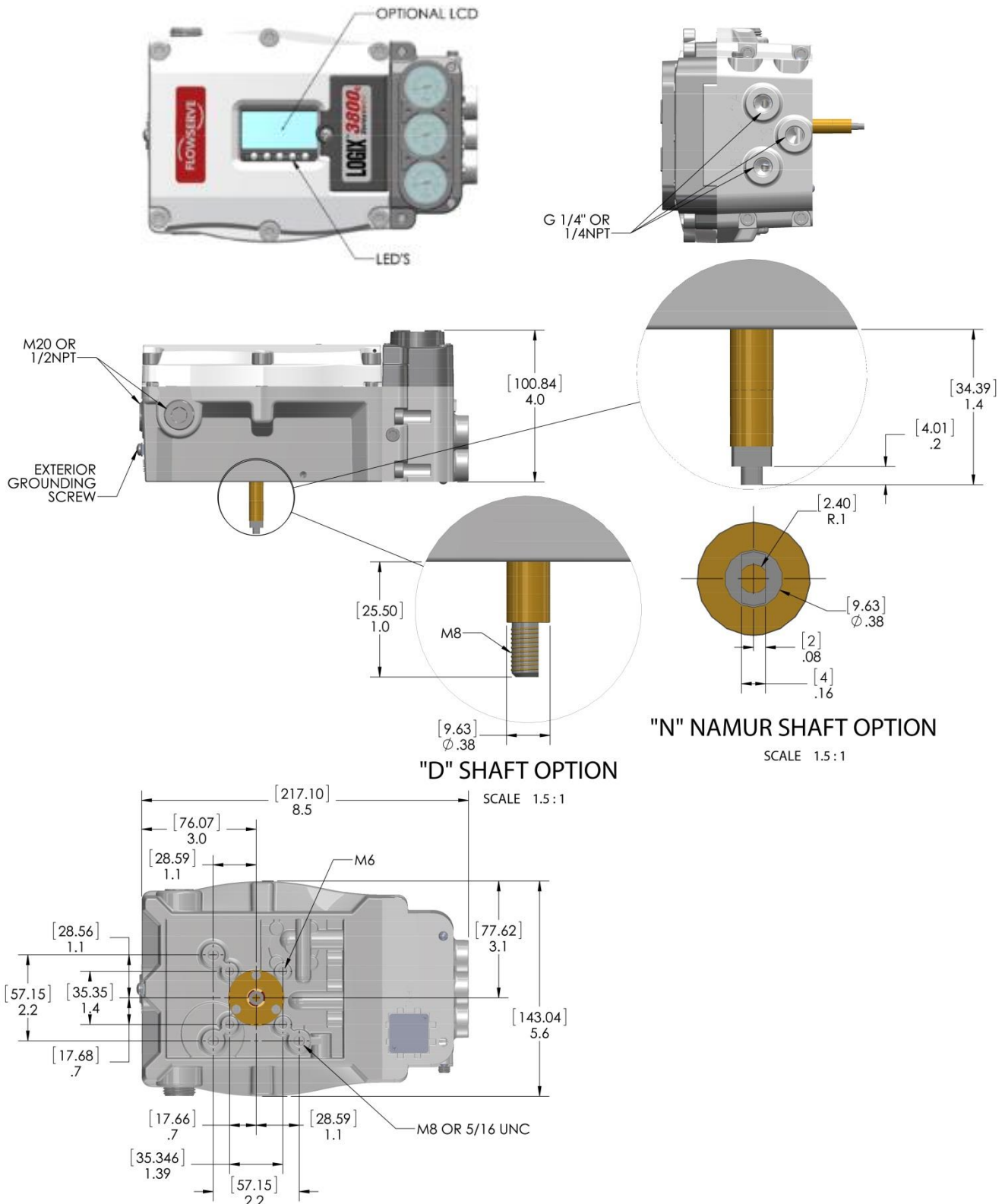

**Figure 40: Positioner Physical Dimensions (EX and SS)**

**14.11 Positioner Dimensions - IS Housing**

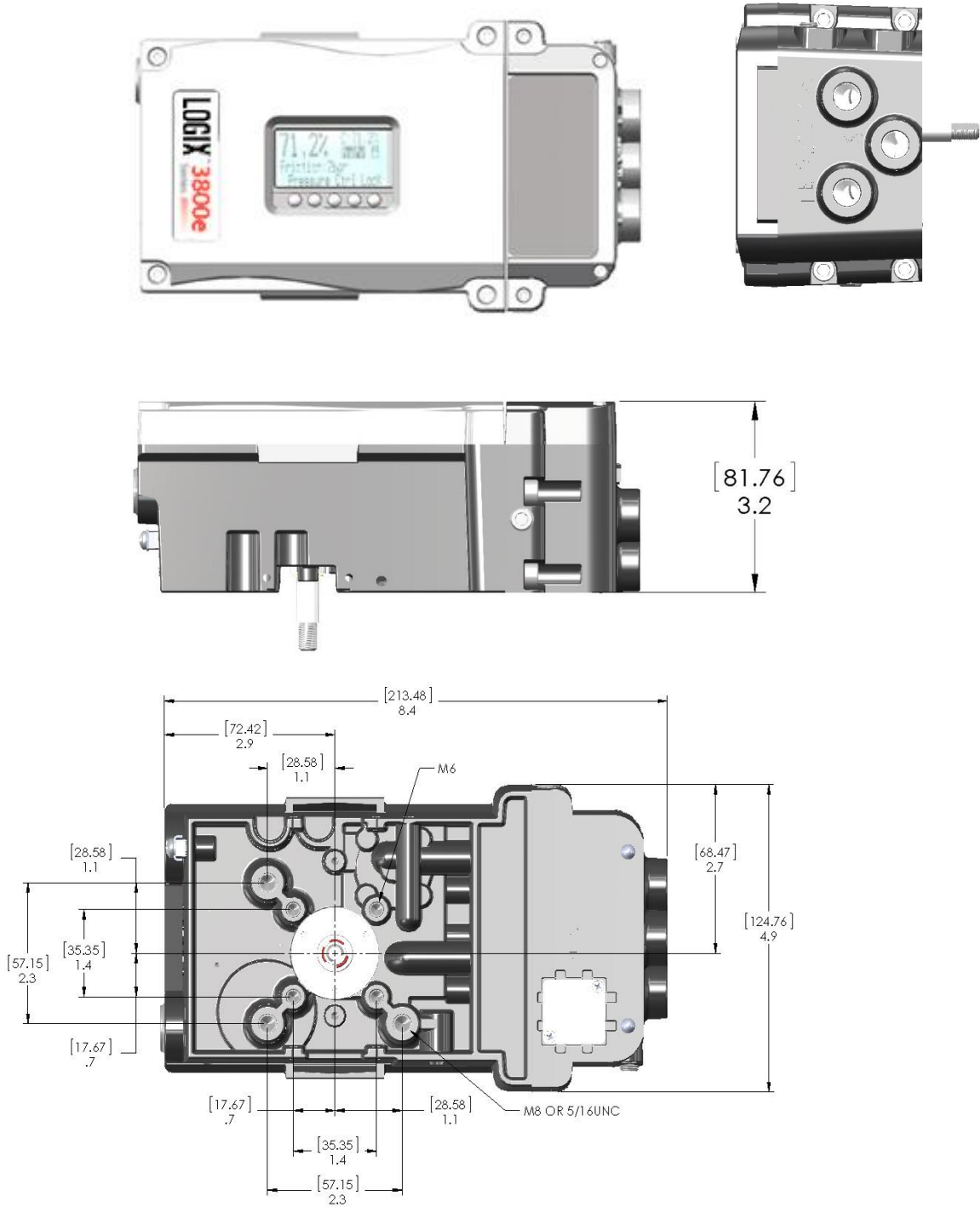

**Figure 41: Positioner Physical Dimensions (IS)**



## 15 Hazardous Location Specifications

### 15.1 Hazardous Location Information

Table 18: Hazardous Location Information – Logix 3800e EX







Certification Code	Area	Protection Method	Markings	Temperature Code	Enclosure Ratings				
 <b>34</b>	<b>US / CANADA</b>	<b>Explosion Proof</b>	XP - Class I, Div 1, Groups B,C,D, T6...T4	T4 = -40C to +85C T5 = -40C to +55C T6 = -40C to +45C	<b>Type 4X, IP66</b>				
			US - Class I, Zone 1, AEx db IIC T6...T4 Gb						
			CANADA- Ex db IIC T6...T4 Gb						
		<b>Intrinsically Safe</b>	IS - Class I,II,III, Div 1, Groups A-G T6...T4						
			US -Class I, Zone 0, AEx ia IIC T6...T4 Ga						
			Canada - Ex ia IIC T6...T4 Ga						
			US -Class I, Zone 0, AEx ib IIC T6...T4 Gb						
			Canada - Ex ib IIC T6...T4 Gb						
			US -Class I, Zone 0, AEx ic IIC T6...T4 Gc						
			Canada - Ex ic IIC T6...T4 Gc						
		<b>Non Incendive / Non Sparking</b>	NI - Class I, Div 2, Groups A,B,C,D T6...T4						
			US - Class I, Zone 0, AEx nA IIC T6...T4 Gc						
			Canada - Ex nA IIC T6...T4 Gc						
			US - Class I, Zone 0, AEx ec IIC T6...T4 Gc						
		<b>Dust</b>	Class II, III, Div 1, Groups E,F,G T6...T4			Tamb = -40C to +85C			
			US - Class I, Zone 21, AEx tb IIC T105°C Db						
Ex ia IIIC T200 156° Da Ta = -40C to +85C									
Canada - Ex tb IIC T105°C Db									
 <b>28</b>	<b>ATEX</b>	<b>Explosion Proof</b>	II 2 G - Ex db IIC T6...T4 Gb	T4 = -40C to +85C T5 = -40C to +55C T6 = -40C to +45C	<b>Type 4X, IP66</b>				
		<b>Dust</b>	II 2 D - Ex tb IIIC T105°C Db Ta = -40C to +85C						
			II 1 D - Ex ia IIIC T200 156° Da Ta = -40C to +85C						
		<b>Intrinsically Safe</b>	II 1 G - Ex ia IIC T6...T4 Ga						
			II 1 G - Ex ib IIC T6...T4 Gb						
			II 3 G - Ex ic IIC T6...T4 Gc						
		<b>Non Sparking</b>	II 3 G - Ex nA IIC T6...T4 Gc						
			II 3 G - Ex ec IIC T6...T4 Gc						
			<b>IECEx</b>			<b>Explosion Proof</b>	Ex db IIC T6...T4 Gb	T4 = -40C to +85C T5 = -40C to +55C T6 = -40C to +45C	<b>Type 4X, IP66</b>
						<b>Dust</b>	Ex tb IIIC T105°C Db Ta = -40C to +85C		
Ex ia IIIC T200 156° Da Ta = -40C to +85C									
<b>Intrinsically Safe</b>	Ex ia IIC T6...T4 Ga								
	Ex ib IIC T6...T4 Gb								
	Ex ic IIC T6...T4 Gc								
<b>Non Sparking</b>	Ex nA IIC T6...T4 Gc								
	Ex ec IIC T6...T4 Gc								

Table 19: Hazardous Location Information – Logix 3800e IS

Certification Code	Area	Protection Method	Markings	Temperature Code	Enclosure Ratings	
	37	US / CANADA	Intrinsically Safe	IS - Class I,II,III Div 1, Groups A-G T6...T4	T4 = -40C to +85C T5 = -40C to +55C T6 = -40C to +45C	Type 4X, IP66
				US -Class I, Zone 0, AEx ia IIC T6...T4 Ga		
				Canada - Ex ia IIC T6...T4 Ga		
				US -Class I, Zone 0, AEx ib IIC T6...T4 Gb		
				Canada - Ex ib IIC T6...T4 Gb		
				US -Class I, Zone 0, AEx ic IIC T6...T4 Gc		
				Canada - Ex ic IIC T6...T4 Gc		
		Non Incendive / Non Sparking	NI - Class I, Div 2, Groups A,B,C,D T6...T4			
			US - Class I, Zone 0, AEx nA IIC T6...T4 Gc			
			Canada - Ex nA IIC T6...T4 Gc			
			US - Class I, Zone 0, AEx ec IIC T6...T4 Gc			
		Dust	Class II, III, Div 1, Groups E,F,G T6...T4	T4 = -40C to +85C T5 = -40C to +55C T6 = -40C to +45C		
			US - Class I, Zone 21, AEx tb IIC T105°C Db	Tamb = -40C to +85C		
			Ex ia IIIC T200 156° Da Ta = -40C to +85C			
			Canada - Ex tb IIC T105°C Db			
	ATEX	Dust	II 2 D - Ex tb IIIC T105°C Db Ta = -40C to +85C	Ta = -40C to +85C	Type 4X, IP66	
			Intrinsically Safe			II 1 D - Ex ia IIIC T200 156° Da Ta = -40C to +85C
		II 1 G - Ex ia IIC T6...T4 Ga				
		Non Sparking		II 1 G - Ex ib IIC T6...T4 Gb		
			II 3 G - Ex ic IIC T6...T4 Gc			
			II 3 G - Ex nA IIC T6...T4 Gc			
			II 3 G - Ex ec IIC T6...T4 Gc			
	IECEx	Dust	Ex tb IIIC T105°C Db Ta = -40C to +85C	T4 = -40C to +85C T5 = -40C to +55C T6 = -40C to +45C	Type 4X, IP66	
			Ex ia IIIC T200 156° Da Ta = -40C to +85C			
		Intrinsically Safe	Ex ia IIC T6...T4 Ga			
			Ex ib IIC T6...T4 Gb			
			Ex ic IIC T6...T4 Gc			
		Non Sparking	Ex nA IIC T6...T4 Gc			
			Ex ec IIC T6...T4 Gc			

## 15.2 Entity Compliant Parameters

See Appendix G - How To Order for complete model listing.

**Table 20: Entity Parameters Models 382Xe**

Logix 3800e Entity Parameters		
Field Connections	4-20	Optional AO
UI (Vmax) =	30 VDC	30 VDC
Ii(Imax) =	380 mA	250 mA
Pi(Pmax) =	5.32W	2.0W
Li =	0	0
Ci =	0	0

## 15.3 Warnings and Special Conditions for Safe Use

### Warning!

- Substitution of components may Impair Intrinsic safety.
- DO NOT OPEN, MAINTAIN OR SERVICE IN AN AREA WHERE AN EXPLOSIVE ATMOSPHERE MAY BE PRESENT

### Special Conditions for Safe Use:

- For Intrinsically Safe installations the positioner must be connected to suitably rated intrinsically safe equipment and must be installed in accordance with applicable intrinsically safe installation standards.
- Use appropriately rated cable insulation at higher temperatures.
- Cable, cable guard, or conductors in conduit should have insulation rated for at least 18K above the maximum expected ambient temperature of the environment or installation.
- Contact Flowserve for Flame Path information.
- The Model 38X0e and 38X1e Positioner enclosures contain aluminum and are considered to present a potential risk of ignition by impact or friction. Care must be taken into account during installation and use to prevent impact or friction. Clean only with damp cloth.
- Provisions shall be made externally to provide transient overvoltage protection to a level not to exceed 140% of the peak rated input voltage.
- Using the box provided on the nameplate, the User shall permanently mark the type of protection chosen for the specific installation. Once the type of protection has been marked it shall not be changed.
- Potential electrostatic charging hazard. Clean only with a damp cloth.
- Discontinue use of equipment if the fasteners securing the enclosure cover or the cover window are damaged. Contact Flowserve for repair.

### AVERTISSEMENT:

- La substitution de composants peut compromettre la sécurité intrinsèque.
- NE PAS OVRIR, MAINTENIR OU SERVIR DANS UNE ZONE OU UNE ATMOSPHERE EXPLOSIVE PEUT ÊTRE PRÉSENTE

Assessed to the following ATEX standards: EN 60079-0: 2012, EN 60079-1: 2014, EN 60079-11: 2012, EN 60079-1:2007, EN 60079-31:2009, EN 60529: 1991/A1:2001

Assessed to the following IECEx standards: IEC 60079-0: 2011, IEC 60079-1:2014, IEC 60079-11: 2011, IEC 60079-15: 2010, IEC 60529: 1999, IEC 60079-1: 2007-04, IEC 60079-31:2013

Assessed to the following US standards: FM Class 3600 :2011, Class 3610 :2010, FM Class 3615:2006, FM Class 3616:2011, FM Class 3810: 2005, ANSI/ISA 60079-0:2013, ANSI/ISA 60079-1:2015, ANSI/ISA 60079-11:2014, ANSI/NEMA 250:2003, ANSI/IEC 60529:2004, INSI/ISA 60079-1: 2009

Assessed to the following CSA standards: CSA-C22.2 No. 0.4:2013, CSA-C22.2 No. 0.5:2012, CSA-C22.2 No. 25:2014, CSA-C22.2 No. 60529:2010, CAN/CSA-C22.2 No. 60079-0:2011, CAN/CSA-C22.2 No. 60079-1:2011, CSA-C22.2 No. 60529:2010, CSA C22.2 No. 157:2012, CSA C22.2 No. 157:2012, CSA C22.2 No. 60079-0 2011, CSA C22.2 No. 60079-11 2011, CSA C22.2 No. 1010.1 2004 (R2009), CSA C22.2 No. 60529 2005

**15.4 Control Drawing – North America Connection Diagram**

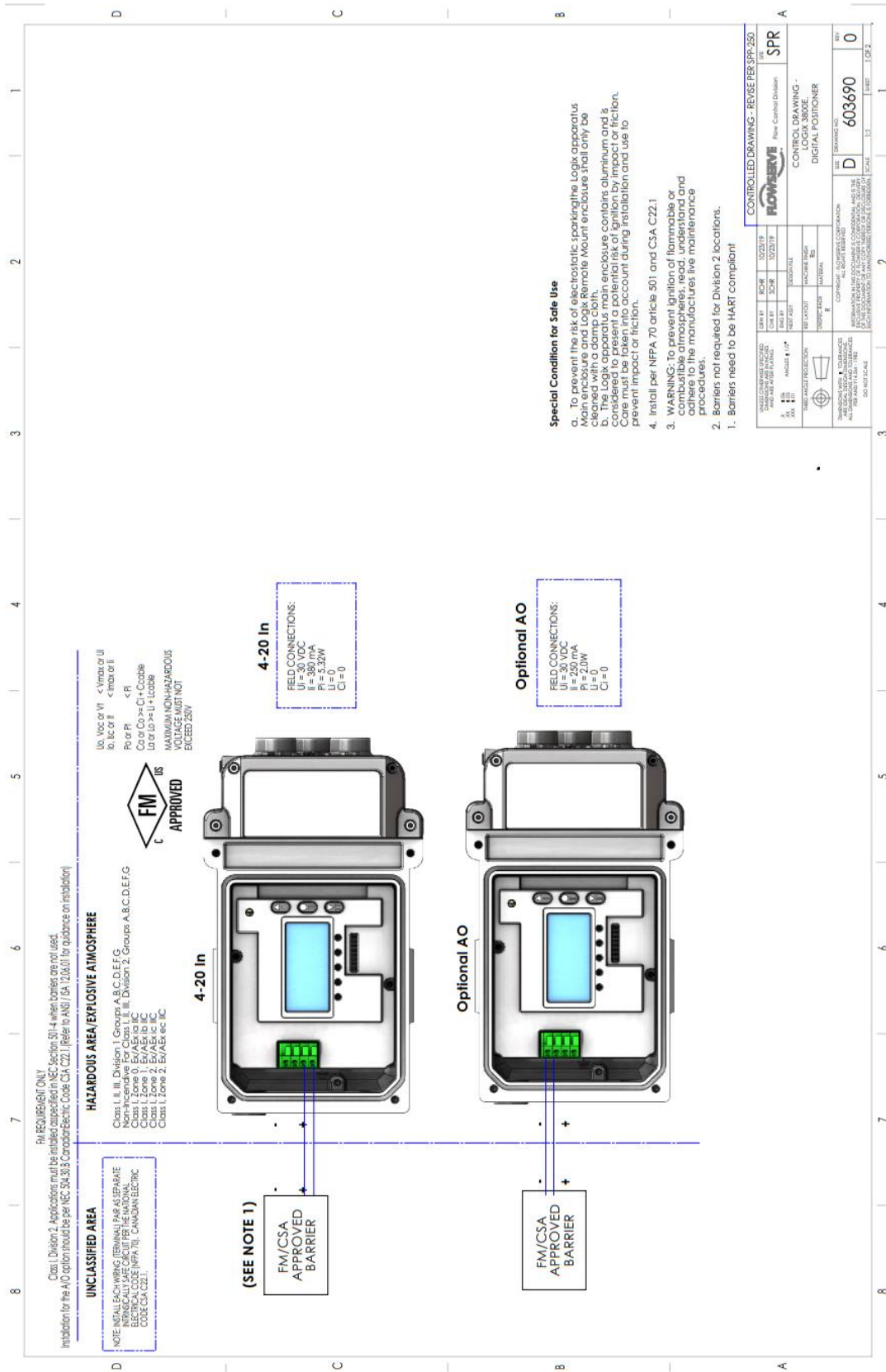

### 15.5 Control Drawing – ATEX / IECEx Connection Diagram

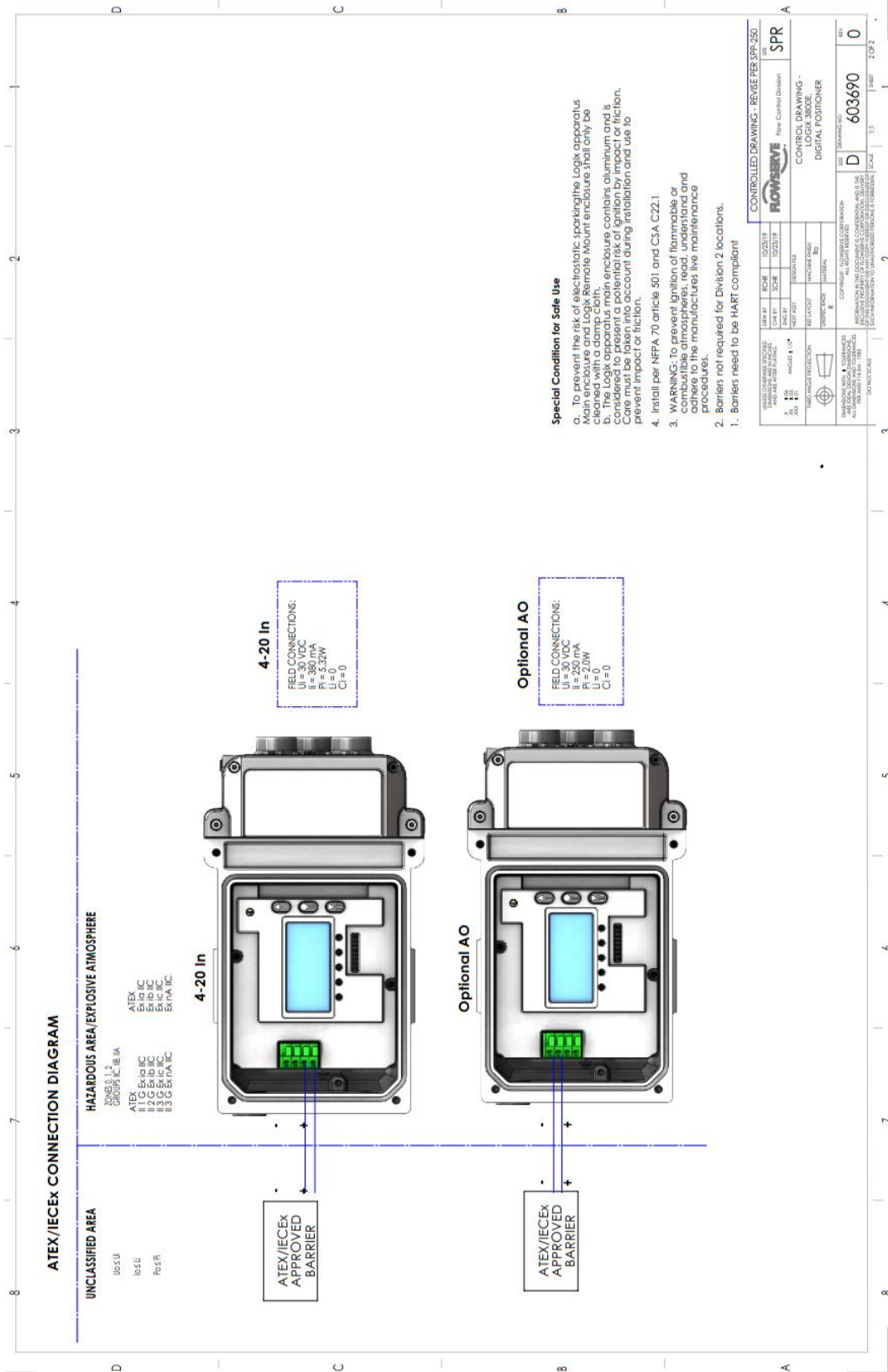

**Special Condition for Safe Use**

- To prevent the risk of electrostatic sparking the Logix apparatus Main enclosure and Logix Remote Mount enclosure shall only be used in an approved ATEX/IECEx enclosure.
- The Logix apparatus main enclosure contains aluminum and is considered to present a potential risk of ignition by impact or friction. Care must be taken into account during installation and use to prevent impact or friction.

- Install per NFPA 70 article 501 and CSA C22.1
- WARNING:** To prevent ignition of flammable or combustible atmospheres, read, understand and adhere to the manufacturer's live maintenance procedures.
- Barriers not required for Division 2 locations.
- Barriers need to be HART compliant

## APPENDIX A – LCD MENU TREE OVERVIEW

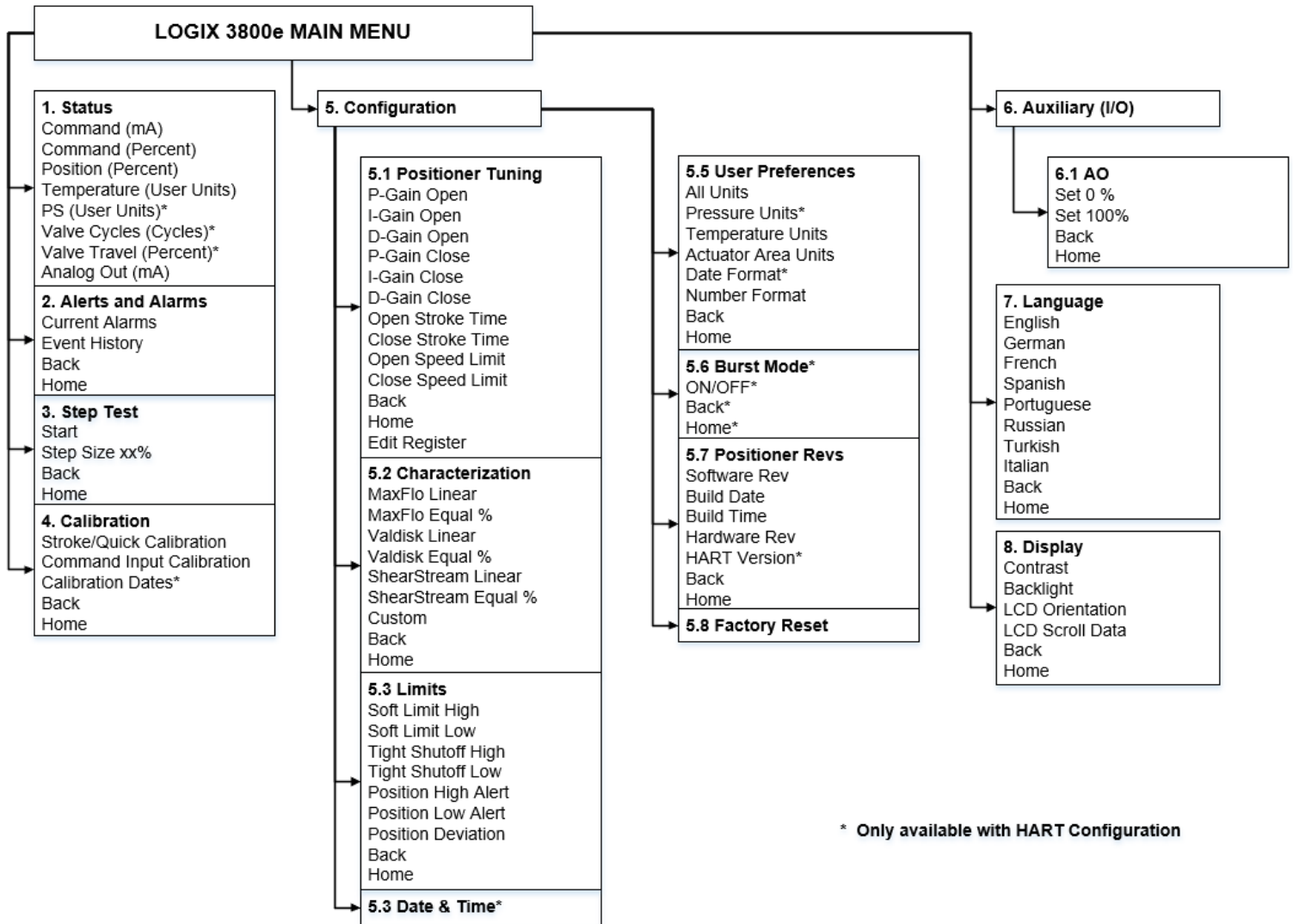

\* Only available with HART Configuration

A



## APPENDIX B – LCD MENU TREE DESCRIPTIONS

Menu Feature	Description	Menu Location	No-Comm	HART
<b>Status</b>	The Status menu is used to view information about the configuration and operation of the system.	1	•	•
Command (mA)	Command (mA) displays the final command in mA.	1.1	•	•
Command (Percent)	Command (Percent) displays the final command in %.	1.2	•	•
Position (Percent)	Position (Percent) displays the valve position in %.	1.3	•	•
Temperature (User Units)	Temperature (User Units) displays the temperature inside the positioner.	1.4	•	•
PS (User Units)		1.5		•
Valve Cycles (Cycles)	Valve Cycles (Cycles) are counted each time the positioner changes direction. The movement must be beyond a dead-band window. This window is set to 0.5% as a default, but can be changed using the DTM.	1.6		•
Valve Travel (Percent)	Valve Travel (Percent) is counted in small increments every time the valve moves beyond the dead-band window. The display of travel is in % of full stroke.	1.7		•
Analog Output (AO)	The Analog Output provides a 4-20 mA feedback mechanism, indicating the position of the valve, to the host system.	1.8	•	•
<b>Alerts and Alarms</b>	The Alerts and Alarms menu show current and past alarms, warnings, alerts, and calibrations.	2	•	•
Current Alarms	Current Alarms displays all events that are actively sounding.	2.1	•	•
Event History	Event History displays past 32 events including alarms, warnings, alerts, and calibrations. Displayed is the event that occurred most recently, first (event 32) with later events recorded below. Each event would have a timestamp and shows if it was turning on or off.	2.2	•	•
Back		2.3	•	•
Home		2.4	•	•
<b>Step Test</b>	The Partial Stroke Test (PST) menu provides the user the ability to start a PST and see the results of the latest PST.	3	•	•
Start	Start allows the user to initialize the (PST).	3.1	•	•
Step Size xx%	Last Result shows “Pass” or “Fail” from the last PST attempt.	3.2	•	•
Back		3.3	•	•
Home		3.4	•	•
<b>Calibration</b>	The Calibration menu allows the user to calibrate the positioner’s sensors. The positioner can accurately control with only a Quick-Cal.	4	•	•
Stroke/Quick Calibration	Stroke/Quick Calibration starts an automatic calibration of the position feedback sensor. The stroke calibration determines the closed (0%) and open (100%) positions of the valve and gathers information about the response of the valve (such as valve stroke time) to determine the gains. The gains are then automatically set. After a stroke calibration, the positioner is ready to control.	4.1	•	•

Menu Feature	Description	Menu Location	No-Comm	HART
Command Input Calibration	Command Input Calibration is used to adjust the input range. Set the lowest current (Set 0%) and the highest current used (Set 100%). The default input range is 4 to 20 mA. The “Set 0%” value must be lower than the “Set 100% value.	4.2	•	•
Calibration Dates	Calibration Dates lists the most recent date of each calibration.	4.3		•
Back		4.4	•	•
Home		4.5	•	•
<b>Configuration</b>		5	•	•
<b>Positioner Tuning</b>	The Configuration – Positioner Tuning menu allows the user to adjust individual tuning parameters manually. All tuning parameters are automatically set to optimal values during Quick-Cal. Typically a Quick-Cal is all that is needed for positioner tuning.	5.1	•	•
P-Gain Open	P-Gain is the proportional, integral, and differential element of the feedback algorithm. This gain is different for the opening and closing directions because typically responsiveness is different in each direction.	5.1.1	•	•
I-Gain Open	I-Gain is the proportional, integral, and differential element of the feedback algorithm. This gain is different for the opening and closing directions because typically responsiveness is different in each direction.	5.1.2	•	•
D-Gain Open	D-Gain is the proportional, integral, and differential element of the feedback algorithm. This gain is different for the opening and closing directions because typically responsiveness is different in each direction.	5.1.3	•	•
P-Gain Close	P-Gain is the proportional, integral, and differential element of the feedback algorithm. This gain is different for the opening and closing directions because typically responsiveness is different in each direction.	5.1.4	•	•
I-Gain Close	I-Gain is the proportional, integral, and differential element of the feedback algorithm. This gain is different for the opening and closing directions because typically responsiveness is different in each direction.	5.1.5	•	•
D-Gain Close	D-Gain is the proportional, integral, and differential element of the feedback algorithm. This gain is different for the opening and closing directions because typically responsiveness is different in each direction.	5.1.6	•	•
Open Stroke Time	Open Stroke Time is the fastest time it took the valve to stroke from 0% to 100% during Quick-Cal.	5.1.7	•	•
Close Stroke Time	Close Stroke Time is the fastest time it took the valve to stroke from 100% to 0% during Quick-Cal.	5.1.8	•	•
Open Speed Limit	Open Speed Limit and Closed Speed Limit are used to prevent the valve from moving too quickly. Speed limits help when the process is sensitive to rapid flow or pressure changes. This shows the time (in seconds) that the positioner will allow the valve to travel a full stroke. This speed limit applies to smaller movements of the valve too.	5.1.9	•	•
Close Speed Limit	Open Speed Limit and Closed Speed Limit are used to prevent the valve from moving too quickly. Speed limits help when the process is sensitive to rapid flow or pressure changes. This shows the time (in seconds) that the positioner will allow the valve to travel a full stroke. This speed limit applies to smaller movements of the valve too.	5.1.10	•	•

B

Menu Feature	Description	Menu Location	No-Comm	HART
Back		5.1.11	●	●
Home		5.1.12	●	●
(Edit Register)	Reserved for service only for writing and reading variables in system.	5.1.13	●	●
<b>Characterization</b>	The Configuration – Characterization menu allows the user to change the characterization of the command. This allows a better match between the input command and the actual fluid flow through the valve. This feature is typically used with valves that have non-linear flow characteristics. The positioner makes a correction by applying an adjustment to the input command according to a characterization curve. The table in this appendix shows the available characterization curve options. Each point of the Custom curve can be adjusted using the ValveSight DTM.	5.2	●	●
MaxFlo Linear	See Appendix C – Programmed Flow Characterization Options for characteristic curve data and illustrated curves	5.2.1	●	●
MaxFlo Equal %	See Appendix C – Programmed Flow Characterization Options for characteristic curve data and illustrated curves	5.2.2	●	●
Valdisk Linear	See Appendix C – Programmed Flow Characterization Options for characteristic curve data and illustrated curves	5.2.3	●	●
Valdisk Equal %	See Appendix C – Programmed Flow Characterization Options for characteristic curve data and illustrated curves	5.2.4	●	●
ShearStream Linear	See Appendix C – Programmed Flow Characterization Options for characteristic curve data and illustrated curves	5.2.5	●	●
ShearStream Equal %	See Appendix C – Programmed Flow Characterization Options for characteristic curve data and illustrated curves	5.2.6	●	●
Custom	Select Custom for a standard 30:1 linear, equal percent rangeability curve. The curve may be customized point-by-point. To modify the Custom curve, use the ValveSight DTM. See Appendix C – Programmed Flow Characterization Options for characteristic curve data and illustrated curves	5.2.7	●	●
Back		5.2.8	●	●
Home		5.2.9	●	●
<b>Limits</b>	Limits allows the user to limit the movement of the valve. Shutoff allows the user to shut the valve with all available force tightly.	5.3	●	●
Soft Limit High	This feature is used to simulate physical blocks on the valve that restrict movement past a set point. Once the Soft Limit is set, the positioner will not attempt to move the valve position (final command) beyond the set point, regardless of the analog or digital command input signal.	5.3.1	●	●
Soft Limit Low	This feature is used to simulate physical blocks on the valve that restrict movement past a set point. Once the Soft Limit is set, the positioner will not attempt to move the valve position (final command) beyond the set point, regardless of the analog or digital command input signal.	5.3.2	●	●
Tight Shutoff High	This feature is used to close or open the valve tightly. It is used when a tight seal is needed or when debris or friction may otherwise interfere with complete closure. When the valve is commanded past the Shutoff points, the pilot relay will direct full supply pressure to the appropriate port, applying all available force to close (or open) the valve. The Shutoff points apply to the Final Command.	5.3.3	●	●

Menu Feature	Description	Menu Location	No-Comm	HART
Tight Shutoff Low	This feature is used to close or open the valve tightly. It is used when a tight seal is needed or when debris or friction may otherwise interfere with complete closure. When the valve is commanded past the Shutoff points, the pilot relay will direct full supply pressure to the appropriate port, applying all available force to close (or open) the valve. The Shutoff points apply to the Final Command.	5.3.4	●	●
Position High Alert	Position High Alert Algorithm for customer's choice	5.3.5	●	●
Position Low Alert	Position Low Alert Algorithm for customer's choice	5.3.6	●	●
Position Deviation	Position Deviation Alert Algorithm for customer's choice	5.3.7	●	●
Back		5.3.8	●	●
Home		5.3.9	●	●
<b>Date &amp; Time</b>		5.4		●
<b>User Preferences</b>	The User Preferences menu allows the user to format how information is displayed.	5.5	●	●
All Units	(North American, SI)	5.5.1	●	●
Pressure Units		5.5.2		●
Temperature Units	(degrees F, degrees C)	5.5.3	●	●
Actuator Area Units	(in2, cm2)	5.5.4	●	●
Date Format		5.5.5		●
Number Format	(Decimal Point, Comma)	5.5.6	●	●
Back		5.5.7	●	●
Home		5.5.8	●	●
<b>Burst Mode</b>	Burst Mode continuously transmits HART information.	5.6		●
ON/OFF	On/Off – Use this feature to turn burst mode on and off.	5.6.1		●
Back		5.6.2		●
Home		5.6.3		●
<b>Positioner Revs</b>		5.7	●	●
SW Rev	The revision of the embedded software.	5.7.1	●	●
Bld Date	The date of the embedded software build.	5.7.2	●	●
Bld Time	The time of day of the embedded software build.	5.7.3	●	●
HW Rev	The revision of the main board.	5.7.4	●	●
HART Ver	The revision of the HART protocol (6, or 7).	5.7.5		●
Back		5.7.6	●	●
Home		5.7.7	●	●
<b>Factory Reset</b>	Use this feature to reset all variables to their factory default state. All of the internal variables are reset including calibration to factory defaults. The positioner must be re-calibrated after a factory reset. Tag names and other user configured limits, alarm settings, and valve information will also be lost and require restoring. A factory reset will always reset the command source to analog 4-20 mA.	5.8	●	●

B

Menu Feature	Description	Menu Location	No-Comm	HART
<b>Auxiliary I/O</b>	The terminal block gives options for analog output (AO).	6	•	•
<b>AO</b>		6.1	•	•
Set 0%	Set the current (mA) that will correspond to the 0% (closed) valve position.	6.1.1	•	•
Set 100%	Set the current (mA) that will correspond to the 100% (open) valve position.	6.1.2	•	•
Back		6.1.3	•	•
Home		6.1.4	•	•
<b>Language</b>		7	•	•
English		7.1	•	•
German		7.2	•	•
French		7.3	•	•
Spanish		7.4	•	•
Portuguese		7.5	•	•
Russian		7.6	•	•
Turkish		7.7	•	•
Italian		7.8	•	•
Back		7.9	•	•
Home		7.10	•	•
<b>Display</b>		8	•	•
Contrast	LCD Contrast. Customer's Choice	8.1	•	•
Backlight	LCD Backlight. Customer's Choice	8.2	•	•
LCD Orientation	(Standard, Rotate 180°)	8.3	•	•
LCD Scroll Data		8.4	•	•
Back		8.5	•	•
Home		8.6	•	•

## APPENDIX C – PROGRAMMED FLOW CHARACTERIZATION OPTIONS

The characterization menu allows the user to change the characterization of the command. This allows a better match between the input command and the actual fluid flow through the valve. This feature is typically used with valves that have non-linear flow characteristics. The positioner makes a correction by applying an adjustment to the input command according to a characterization curve. The table below shows the available characterization curve options. Each point of the Custom curve can be adjusted using the ValveSight DTM.

Command Input	Final Command							
	Characterization DIP set to "Linear"	Characterization DIP set to "Other"						
	Linear	MaxFlo Linear	MaxFlo =%	Valdisk Linear	Valdisk =%	Shear-Stream Linear	Shear-Stream =%	Custom (Default) (Linear =%)
0.0	0.00	0.00	0.00	0.00	0.00	0.00	0.00	0.00
5.0	5.00	6.50	1.00	13.00	4.00	25.00	8.00	0.62
10.0	10.00	11.60	2.00	20.00	6.00	35.00	14.00	1.35
15.0	15.00	16.20	3.00	26.25	7.80	44.00	17.00	2.22
20.0	20.00	20.50	4.40	32.10	9.30	50.20	21.00	3.25
25.0	25.00	24.60	5.80	37.50	11.50	55.50	24.00	4.47
30.0	30.00	28.50	7.40	42.60	14.00	60.20	27.50	5.91
35.0	35.00	32.40	9.30	47.40	16.50	64.30	31.50	7.63
40.0	40.00	36.20	11.20	51.80	19.30	68.00	35.50	9.66
45.0	45.00	40.00	13.50	56.00	22.50	71.50	39.50	12.07
50.0	50.00	43.80	16.10	60.00	26.00	74.70	43.90	14.92
55.0	55.00	47.60	19.10	63.60	30.00	77.70	48.10	18.31
60.0	60.00	51.50	22.40	67.20	34.70	80.50	52.80	22.32
65.0	65.00	55.50	26.20	70.60	39.60	83.20	57.40	27.08
70.0	70.00	59.50	30.60	73.90	45.10	85.90	62.40	32.71
75.0	75.00	63.80	35.70	77.20	51.30	88.40	67.50	39.40
80.0	80.00	68.20	41.70	81.30	57.80	90.80	72.90	47.32
85.0	85.00	73.00	48.90	84.00	64.80	93.20	78.60	56.71
90.0	90.00	78.40	57.70	87.80	72.50	95.50	84.70	67.84
95.0	95.00	85.00	69.20	92.10	81.30	97.80	91.20	81.03
100.0	100.00	100.00	100.00	100.00	100.00	100.00	100.00	100.00

C



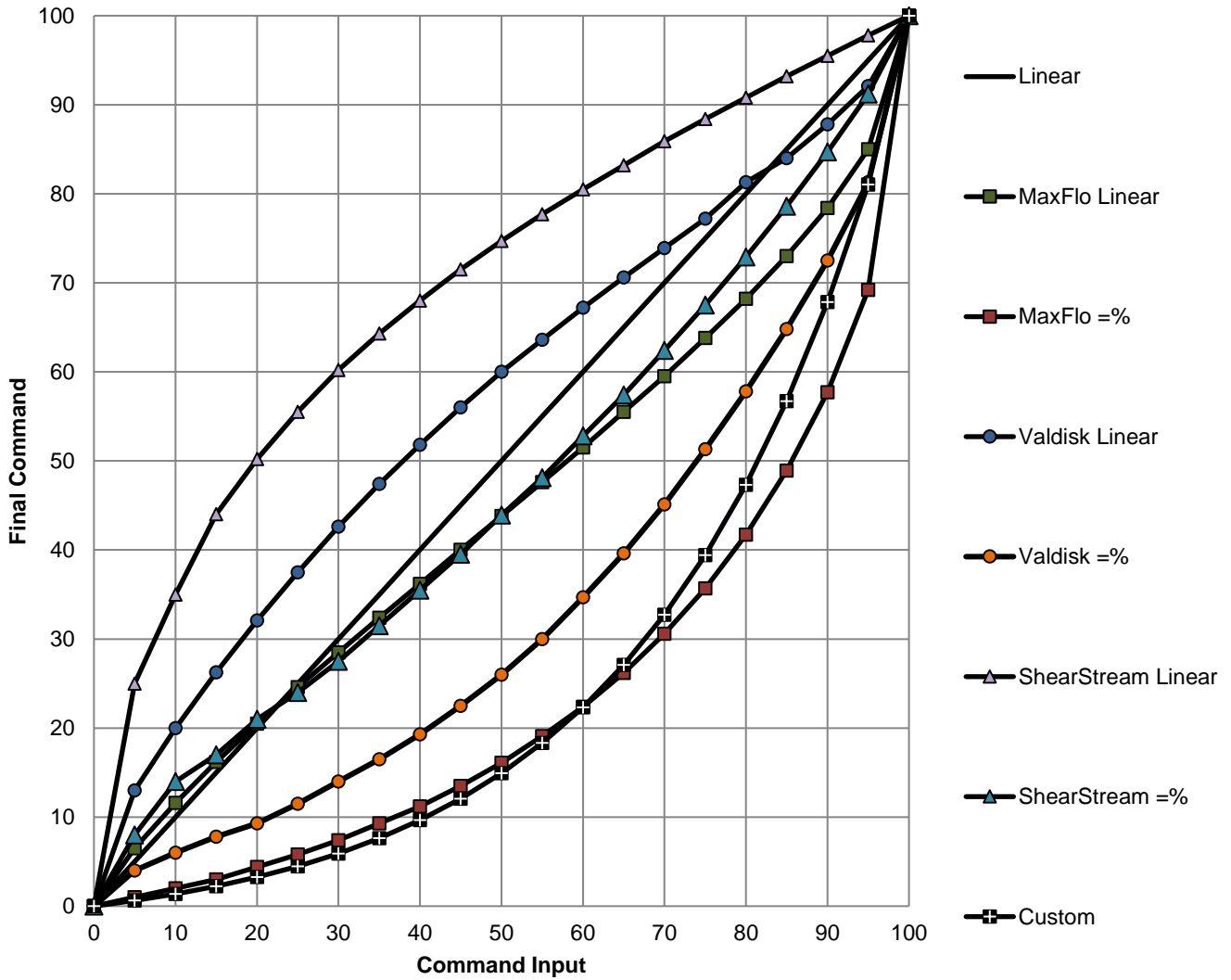

**Figure 42: Characterization Curve Options**

## APPENDIX D – 4-BLINK STATUS CODES

**NOTE:** Not all codes apply to all positioners. The order of sorting is

Color Code	Status	Color Code	Status
	Power ON		Temperature High Warning
	Calibration Succeeded	GBYOR	Temperature Low Warning
	Tight Shut Off Mode		Valve Opened Too Far Warning
G	Local Interface Off	YYGG	Valve Closed Too Far Warning
G	Digital Command Mode	YYGY	Supply Pressure High Warning
G	Initializing	YYGY	Supply Pressure Low Warning
G	Test Mode	YYOR	System Exception Warning
G	Squawk Mode	YYYO	CPU Usage Warning
G	Soft Stop High Limit Alert	YYYO	RAM Cyclic Redundancy Check Error
G	Soft Stop Low Limit Alert	YYYO	NVMEM CRC Error
G	Pressure Calibration Required	YYR	Flash CRC Error
G	AO Input Set 0%	YYOG	Button Stuck On
G	AO Input Set 100%	YRYG	Stroke Calibration in Progress
G	Calibration Type Set	YRYG	Feedback Calibration in Progress
G	Signature or Partial Stroke Test in Progress	YRYG	Pressure Calibration in Progress
G	Command Input Set 0%	YRYG	Command Input Calibration in Progress
G	Command Input Set 100%	RGGG	Analog Output Calibration in Progress
G	Jog Command Mode	RGGG	Relay Characterization in Progress
G	Position High Limit Alert	RGGY	Command Input Range Too Small
G	Position Low Limit Alert	RGGR	Command Input Below ADC Range
G	Valve Cycles Warning	RGYG	Command Input Above ADC Range
G	Valve Travel Warning	RGYR	Position Range Too Small
	Relay Cycles Warning		Inner Loop Offset Time Out
	Relay Travel Warning		Settle Time Out
	Jog Calibration Set 100% Position		No Motion Time Out
	Position Recovery Mode		Analog Output Range Too Small

D



Color Code	Status	Color Code	Status
	Relay Calibration Error		Position Sensor Failure Alarm
	Calibration Required		Port S Out of Range
	Position Feedback Calibration Required		Port S Range Too Small
	Stroke Shift		Pressure Sensor Failure
	Stroke Span Increase		Feedback Linkage Alarm
	Stroke Span Decrease		Relay Can't Open
	Valve Can't Open Alarm		Relay Can't Shut
	Valve Can't Shut Alarm		Relay Sensor Failure
	Supply Pressure Low Alarm		Relay Type Unknown
	Analog Output No Loop Power		Relay Inner Loop Offset Out-of-Range Warning
	Analog Output Error		Position Deviation Alarm

R  
R  
R  
R  
R  
R  
R  
R  
R  
R  
R

RYRG  
RYRY  
RYRY  
PVPV  
RRYR  
RRYR  
RRYR  
RRYR  
RRYO  
RRRR

RYYO

## APPENDIX E – STATUS CODE DESCRIPTIONS

Name	Description	Possible Solution	LED Color Code
Analog Output Calibration in Progress	The analog output calibration sequence is in progress.	The calibration can be canceled from the Analog Output Calibration page of the DTM, from the handheld, or by briefly pressing all three buttons at once.	
Analog Output Error	The Analog Output circuit is not producing the expected output current.	Check AO loop wiring and ensure adequate compliance voltage. Replace electronics assembly if the error persists.	
Analog Output No Loop Power	The Analog Output terminals have no loop power. The positioner previously detected power on the terminals.	Check terminal connection. Mask the terminals if the circuit is not used.	
Analog Output Range Too Small	During a Analog Output calibration the difference between the milliamp signal at 0% and the milliamp signal at 100% was too small.	Recalibrate making sure to use a larger difference between signal limits. This notification can be cleared by briefly pressing the QUICK-CAL button.	
AO Input Set 0%	An Analog Output Calibration has been started using the buttons (not LCD) and the positioner is waiting for the user to adjust the output current to 0% via the I and III Buttons, then press the QUICK-CAL button to accept.	Complete Calibration.	
AO Input Set 100%	An Analog Output Calibration has been started using the buttons (not LCD) and the positioner is waiting for the user to adjust the output current to 100% via the I and III Buttons, then press the QUICK-CAL button to accept.	Complete the calibration.	
Button Stuck On	One of the three buttons (internal or external) is stuck in the on state.	Manipulate the buttons to attempt to unstick them. Clean the buttons with soft moist cloth to prevent buildup of debris.	
Calibration Required	A factory reset was performed and the positioner has not yet been calibrated. The unit will not respond to commands and will remain in the failsafe position until a calibration is successfully completed.	Perform a Stroke Calibration (QUICK-CAL) by holding the QUICK-CAL button down for 3 seconds, or perform a Pressure or Friction calibration if desired. See section 9, Operation – Calibration And Control for warnings.	
Calibration Succeeded	The last calibration succeeded.	Blink code will terminate automatically.	
Calibration Type Set	The user has selected a combination of key presses (Hot Key) that initiates a calibration. The positioner is waiting for the user to select the type of calibration to run.	Refer Appendix F – Hot Keys to see the calibration options.	

E

Name	Description	Possible Solution	LED Color Code
Command Input Set 0%	A Command Input Calibration has been started using the buttons (not LCD) and the positioner is waiting for the user to adjust the loop current to 0% and press the QUICK-CAL button to accept.	Complete the calibration.	
Command Input Set 100%	A Command Input Calibration has been started using the buttons (not LCD) and the positioner is waiting for the user to adjust the loop current to 100% and press the QUICK-CAL button to accept.	Complete the calibration.	
Command Input Above ADC Range	During Command Loop Calibration, the 100% signal was out of the Analog to Digital Converter (ADC) range.	Replace the electronics assembly.	
Command Input Below ADC Range	During Command Loop Calibration, the 0% signal was out of the Analog to Digital Converter (ADC) range.	Replace the electronics assembly.	
Command Input Calibration in Progress	The command input calibration sequence is in progress.	The calibration can be canceled from the Command Calibration page of the DTM, from the handheld, or by briefly pressing all three buttons at once.	
Command Input Range Too Small	During a Command Loop Calibration, the difference between the signal at 0% and the signal at 100% was too small. The system is designed to accept a difference greater than 5 mA.	Recalibrate making sure to use a larger difference between command signal limits. The difference must exceed 5 mA.	
CPU Usage Warning	The CPU usage is too high.	Update the firmware.	
Digital Command Mode	The input command is set by a digital HART command instead of the 4-20 mA signal.	The input command source can be changed back to the 4-20 mA signal by using a handheld, the Dashboard page of the DTM, or performing a manual Command Reset. Perform the Command Reset by holding both the I and III buttons and briefly pressing the QUICK-CAL button.	
Factory Reset State	The positioner is in factory reset state. Calibration is required to enable control.	Perform a Stroke Calibration (QUICK-CAL).	
Feedback Calibration in Progress	A feedback calibration sequence is in progress. Turn the follower arm 2 full rotations over 10 seconds.	Rotate the follower arm 2 full rotations over 10 seconds. The calibration can be canceled from the Sensor Calibration page of the DTM, from the handheld, or by briefly pressing all three buttons at once.	
Feedback Linkage Alarm	The feedback linkage is broken or the position feedback sensor is out of range.	Fix broken linkage or recalibrate the stroke.	

Name	Description	Possible Solution	LED Color Code
Flash CRC Error	The FLASH program memory is corrupt. This will trigger the Memory Error Warning.	Reprogram the main board with the latest firmware. If this error persists, replace the main board.	
Initializing	The positioner has powered up and is displaying a blink sequence 3 times.	Wait for 3 blink sequences to complete.	
Inner Loop Offset Time Out	During calibration the Inner Loop Offset (ILO) value did not settle. This could result in less accurate positioning.	Repeat the stroke calibration to get a more accurate ILO value. To proceed using the less accurate ILO value, this error may be cleared by briefly pushing the QUICK-CAL button. Lowering the setting on the gain selection switch may help if the actuator is unstable during the calibration.	Y Y Y R G G Y R R G G R
Jog Calibration Set 100% Position	During a jog calibration, the unit is waiting for the user to manually adjust the valve position to the desired 100% open position.	Use the I and III buttons on the positioner to adjust the valve to the desired fully open position. Press the QUICK-CAL button to accept.	Y G G R
Jog Command Mode	The positioner has been placed in a local override mode where the valve can only be stroked using the I and III buttons. The positioner will not respond to analog or digital input commands from HART.	Control the valve using the I and III buttons. This mode may be cancelled by pushing the QUICK-CAL button.	G R R Y
Local Interface Off	Control and configuration features are locked at the positioner's local interface. This is to prevent unauthorized or accidental adjustments. The buttons can still be used to view information on the LCD. The status code is only present for a short time when the user attempts to make a change through the display menu.	The DTM's Local Interface page is used to unlock the local interface, turn this feature on and off, and to set the PIN. For temporary access, a Personal Identification Number (PIN) can be entered from the positioner if an LCD is installed.	G G Y G
No Motion Time Out	During a stroke calibration, there was no valve motion detected. Because some valves are quite large, this indicator can take up to 9 minutes to detect an error.	Check linkages and air supply to make sure the system is properly connected. If the time out occurred because the actuator is very large then simply retry the QUICK-CAL and the positioner will automatically allow for a larger actuator by doubling the time allowed for movement. This error may be cleared by briefly pushing the QUICK-CAL.	R G Y Y Y Y Y R
NVMEM CRC Error	The CRC test of the internal data did not pass. This may affect the function of the positioner in various ways or not at all. This will trigger the Memory Error Warning.	Error may clear with time. If error persists, cycle power and complete a QUICK-CAL. If the error still persists, perform a factory reset or replace the main circuit board.	

E



Name	Description	Possible Solution	LED Color Code
Port S Out of Range	The supply pressure sensor (Port S) is either saturated with a very high pressure or the sensor is broken.	Check the supply pressure and the supply pressure reference. Ensure the supply pressure is less than 10.3 bar (150 PSI). Calibrate pressure sensors. Replace the electronics assembly if the condition persists.	
Port S Range Too Small	During a pressure sensor calibration, the range of applied pressures to the pressure sensor port (port S) was too small for optimum performance or the pressure sensor has failed.	Adjust the supply pressure to a higher value so the positioner can properly span the sensors, then recalibrate. If the problem persists, replace the electronic assembly.	
Position Deviation Alarm	The difference between the command and the actual position has been greater than the user set limit for longer than a user set time.	Review active alarms and warnings to find root causes of this alarm. The deviation settings can be changed in the Valve Health page of the DTM.	
Position Feedback Calibration Required	Position feedback calibration required	Perform a Position Feedback Calibration. See Appendix F – Hot Keys.	
Position High Limit Alert	The position has reached, or is exceeding, a user defined upper position indicator. This is similar to a limit switch indicator.	Set the limit to a higher value if more travel is needed, or adjust the command signal back in the specified range.	
Position Low Limit Alert	The position has reached, or is exceeding a user defined lower position indicator. This is similar to a limit switch indicator.	Set the limit to a lower value if more travel is needed, or adjust the command signal back in the specified range.	
Position Range Too Small	During calibration, the range of motion of the position feedback arm was too small for optimum performance.	Check for loose linkages and/or adjust the feedback pin to a position closer to the follower arm pivot to create a larger angle of rotation and recalibrate. The minimum angle of rotation should be greater than 15 degrees. Briefly pressing the QUICK-CAL button acknowledges this condition and the positioner will operate using the short stroke calibration if otherwise a good calibration.	
Position Sensor Failure Alarm	The feedback arm may be disconnected from the valve assembly or the sensor has failed.	Check the feedback arm linkage. Recalibrate. If the problem persists return the unit for repair.	
Power On	Power On	No issues.	
Pressure Calibration in Progress	A pressure calibration sequence is in progress.	The calibration can be canceled from the Pressure Calibration page of the DTM, or by briefly pressing the QUICK-CAL button.	

Name	Description	Possible Solution	LED Color Code
Pressure Calibration Required	A Factory Pressure Calibration has not been performed. Unlike a regular pressure sensor calibration, a Factory Pressure Calibration saves the calibration values to memory, making them available should a factory reset be performed. Proper pressure sensor calibration is required for proper pressure sensing and diagnostics. Calibration values from a regular pressure sensor calibration will be lost when a factory reset is performed. Typically, no pressure calibration is required with a new positioner.	Contact your Flowserve representative.	
Pressure Sensor Failure	One or more pressure sensors is bad. An algorithm that checks the relationship between PA, PB, and PS during operation has detected an error.	Calibrate pressure sensors. If the problem persists, replace the electronic assembly.	
Position Recovery Mode	Recovering from position measurement out of calibrated range.	Check valve linkage configuration, recalibrate if needed.	
RAM Cyclic Redundancy Check Error	The RAM data memory is corrupt. This will trigger the Memory Error Warning.	If this error persists, replace the main board.	
Relay Calibration Error	The relay is not moving far enough.	Check relay installation, alignment, and magnet. Re-run the relay characterization.	
Relay Can't Open	The pilot relay appears to be unable to move in the open (pressurized) direction and is not responding. This could be due to a broken or out of calibration sensor, a broken piezo, stuck poppet, or a wire connection problem. This will trigger a Driver Module Alarm.	Check the internal wiring harnesses for good connections. Check the relay for sticking problems. If the positioner still does not operate replace the piezo, and/or relay assembly.	
Relay Can't Shut	The pilot relay appears to be unable to move in the lower (depressurized) direction and is not responding. This could be due to a broken or out of calibration sensor, a broken piezo, stuck poppet, or a wire connection problem. This will trigger a Driver Module Alarm.	Check the internal wiring harnesses for good connections. Check the relay for sticking problems. If the positioner still does not operate replace the piezo, and/or relay assembly.	
Relay Characterization in Progress	A relay calibration is in progress. The position sets the pressures equal while the user adjusts the relay adjustment screw.	Adjust the relay set screw until the pressures in port A and port B are approximately 90% of supply pressure. Then briefly press the QUICK-CAL button to end.	

E

Name	Description	Possible Solution	LED Color Code
Relay Cycles Warning	The relay cycle limit, set by the user, has been exceeded. The relay cycles indicate the activity level of the pilot relay as it maintains a valve's position. Excessive cycles can contribute to a worn relay which can lead to high air consumption.	Inspect for high air consumption and signs of wear.	
Relay Inner Loop Offset Out of Range Warning	The Inner Loop Offset is not close to expected value. This will trigger a Driver Module Alarm.	Check the sensor connector. Verify the relay magnet is not loose. Replace the relay. Replace the main board.	
Relay Sensor Failure	The relay sensor has failed or no magnet is detected	Check for magnet	
Relay Travel Warning	The total accumulated relay travel (% of full relay span) set by the user has been exceeded. The relay travel indicates the activity level of the relay as it maintains a valve's position. Excessive travel can contribute to a worn pilot relay which can lead to high air consumption.	Inspect for high air consumption and signs of wear.	
Relay Type Unknown	Relay Type Unknown	Check the model code, update embedded software.	
Settle Time Out	During calibration, the position feedback sensor or supply pressure (for pressure calibration) showed movement, but did not settle.	Check for loose linkages or a loose positioner sensor. Check for regulated supply pressure. This error may appear on some very small actuators during the initial calibration. Recalibrating may clear the problem, or this error may be cleared by briefly pushing the QUICK-CAL button.	
Signature or Partial Stroke Test in Progress	The positioner is in Out of Service (OOS) mode because a test or signature has been initiated. These include Step Test, Ramp Test, or Partial Stroke Test.	Signatures and tests can be defined, initiated, and cancelled through the Off-Line Diagnostics pages of the DTM.	
Soft Stop High Limit Alert	The Final Command would move the valve beyond the user set Soft Limit, but the internal software is holding the position at the limit. The function is similar to a mechanical limit stop except it is not active if the unit is un-powered.	If more travel is needed, reset the Soft Limits. If not, adjust the Final Command signal back into the specified range.	
Soft Stop Low Limit Alert	The Final Command would move the valve beyond the user set Soft Limit, but the internal software is holding the position at the limit. The function is similar to a mechanical limit stop except it is not active if the unit is un-powered.	If more travel is needed, reset the Soft Limits. If not, adjust the Final Command signal back into the specified range.	

Name	Description	Possible Solution	LED Color Code
Squawk Mode	A user has set the positioner to flash a special sequence so that it can be visually located.	This mode is cancelled if one of the following occurs: 1) The QUICK-CAL button is briefly pressed. 2) The Squawk mode is selected again remotely. 3) More than one hour has passed since the command was issued.	
Stroke Calibration in Progress	A stroke calibration sequence is in progress.	The calibration can be canceled from the Sensor Calibration page of the DTM, from the handheld, or by briefly pressing the QUICK-CAL button.	G B B B
Stroke Shift	The 0% and 100% valve positions have both shifted in the same direction since the last stroke calibration. This may be related to a bent or adjusted feedback linkage, or loose positioner mounting.	Ensure the feedback linkage is not bent and the positioner is mounted securely. This notification can be cleared by briefly pressing the QUICK-CAL button.	Y R Y G R G R Y
Stroke Span Decrease	The 0% and 100% valve positions are closer together compared to the last stroke calibration. This could indicate debris or build up at valve seat.	Inspect valve or schedule valve for inspection. This notification can be cleared by briefly pressing the QUICK-CAL button.	R G R Y
Stroke Span Increase	The 0% and 100% valve positions are farther apart compared to the last stroke calibration. This could indicate seat wear.	Inspect valve or schedule valve for inspection. This notification can be cleared by briefly pressing the QUICK-CAL button.	R G R Y
Supply Pressure High Warning	The supply pressure is above the user set warning limit. Supply pressure that exceeds the maximum rating on the actuator can become a potential hazard.	Regulate the supply pressure at the positioner below the maximum limit recommended for your actuator. Recalibrate pressure sensors. Check the pressure sensor board connections. Replace pressure sensor board if necessary.	Y Y G R
Supply Pressure Low Alarm	The supply pressure is below the user set warning limit. Low supply pressure can cause poor valve response or positioner failure. The minimum recommended supply pressure for proper operation is 1.3 bar (19 PSI).	Regulate the supply pressure at the positioner above 1.3 bar (19 PSI). Ensure system air/gas supply is adequate. Repair kinked or restricted supply tubing. Check for pneumatic leaks in the actuator and actuator tubing. Recalibrate pressure sensors. Check the pressure sensor board connections and replace pressure sensor board if necessary.	R Y Y G

E

Name	Description	Possible Solution	LED Color Code
Supply Pressure Low Warning	The supply pressure is below the user set warning limit. Low supply pressure can cause poor valve response or positioner failure. The minimum recommended supply pressure for proper operation is 1.3 bar (19 PSI).	Regulate the supply pressure at the positioner above 1.3 bar (19 PSI). Ensure system air/gas supply is adequate. Repair kinked or restricted supply tubing. Check for pneumatic leaks in the actuator and actuator tubing. Recalibrate pressure sensors. Check the pressure sensor board connections and replace pressure sensor board if necessary.	Y Y Y G
System Exception Warning	System has logged an internal error.	Update the firmware.	
Temperature High Warning	The temperature of the internal electronics has exceeded the manufacturer set limit of 85°C (176°F). High temperature may affect performance or limit the life of the positioner.	Regulate the temperature of the positioner by shading or cooling supply gas. If the temperature reading is in error, replace the main board.	Y Y Y O Y Y G G
Temperature Low Warning	The temperature of the internal electronics has exceeded the manufacture set limit of -40°C (-40°F). Low temperature may inhibit responsiveness and accuracy.	Regulate the temperature of the positioner. If the temperature reading is in error, replace the main circuit board.	Y Y G G
Test Mode	Test mode is active.	Power cycle to leave test mode.	G G R R
Tight Shut Off Mode	Also called MPC. The Final Command is beyond the user set limit for the tight shutoff feature and the positioner is applying full actuator pressure to close (or open) the valve. This is a normal condition for all valves when closed. The factory default setting triggers this at command signals below 1%. This indication may also occur on 3 way valves at both ends of travel if the upper Tight Shut Off value has been set.	If tight shutoff is not desired reset the tight shutoff limits or adjust the command signal inside of the specified Tight Shut Off values.	G G G Y
Valve Can't Open Alarm	Pressure has been applied (or removed) to open the valve, but the valve is not opening. This may be caused by excessive friction.	Verify adequate supply pressure is applied. Verify the feedback linkage is connected. View the friction trends if available. Consider the following: Clear any external or internal mechanical obstruction, loosen the packing, clean the stem, repair or replace the actuator, repair the valve if galling is suspected.	R Y G G

Name	Description	Possible Solution	LED Color Code
Valve Can't Shut Alarm	Pressure has been removed (or applied) to close the valve, but the valve is not closing. This may be caused by excessive friction.	Verify adequate supply pressure is applied. Verify the feedback linkage is connected. View the friction trends if available. Consider the following: Clear any external or internal mechanical obstruction, loosen the packing, clean the stem, repair or replace the actuator, repair the valve if galling is suspected. <b>R Y G G</b>	
Valve Closed Too Far Warning	While the valve was in use, it closed farther than it did at the last calibration by 0.5%.	Check the feedback arm linkage and ensure the valve stem connection is tight. Recalibrate the stroke. If the process cannot be interrupted a service technician may be able to adjust the calibration. <b>Y Y G Y</b>	
Valve Cycles Warning	The valve cycle limit has been exceeded. Each cycle represents two reversals of the direction of valve movement. The cycle counting criterion and count limit are set by the user to track the usage of the valve.	Follow routine procedures for maintenance when the limit is reached such as checking the packing tightness, and checking linkages for wear, misalignment, and tightness. After maintenance, reset the cycle accumulator. <b>Y G G Y</b>	
Valve Opened Too Far Warning	While the valve was in use, it opened farther than it did at the last calibration by 0.5%.	Check the feedback arm linkage and ensure the valve stem connection is tight. Recalibrate the stroke. If the process cannot be interrupted a service technician may be able to adjust the calibration. <b>Y Y G Y</b>	
Valve Travel Warning	The total accumulated valve travel limit has been exceeded. The travel is accumulated in both directions. The travel counting criterion and limit are set by the user to track the usage of the valve.	Follow routine procedures for maintenance when the limit is reached such as checking the packing tightness, and checking linkages for wear, misalignment, and tightness. After maintenance, reset the travel accumulator. <b>Y G G Y</b>	

E



## APPENDIX F – HOT KEYS

Hot keys are quick button combinations to access different features without the use of the LCD menu. This table shows the key combinations and the related features.

Function	Step	Procedure	Button		
			I	II	III
<b>Access Menu</b>	Access the user menu.	Press I or III briefly.	Brief		Brief
	Select menu item.	Press I or III briefly.	As Needed		As Needed
	Exit the user menu.	Select the Back or Exit option in the menu and press II briefly.		Brief	
<b>Quick Cal</b>	Initiate a Quick-Cal stroke calibration.*	Hold II for 3 seconds.		3s	
	(For Jog Calibration, set 100% position.)	Press II briefly.		Brief	
	Abort a Quick-Cal stroke calibration (or End Jog Cal).	Press II briefly.		Brief	
<b>Factory Reset</b>	Set positioner to Factory Reset state.	Hold II while applying power to the positioner.		Brief	
<b>Local Valve Control</b>	Initiate local valve control.	Hold I and III together for 3 seconds.	3s		3s
	Move valve toward opened position.	Press I as needed.	As Needed		
	Move valve toward closed position.	Press III as needed.			As Needed
	Exit Local valve control.	Press II briefly.		Brief	
<b>Command Source Reset (HART)</b>	Change from digital command to analog command.	Hold I for 3 seconds.	3s		
<b>Command Input Calibration (HART)</b>	Initiate calibrations.	Hold I, II and III together for 3 seconds.	3s	3s	3s
	Select Command Input Calibration and allow setting 0%	Press II briefly.		Brief	
	Set 0%	Set input value and press II briefly.		Brief	
	Set 100% and complete calibration.	Set input values and press II briefly to complete calibration.		Brief	
	Abort Calibration at any time.	Press I, II and III together briefly.	Brief	Brief	Brief

Function	Step	Procedure	Button		
			I	II	III
Analog Output Calibration (HART)	Initiate calibrations.	Hold I, II and III together for 3 seconds.	3s	3s	3s
	Select Analog Output calibration and allow setting 100%.	Press III briefly.			Brief
	Adjust output current to 100% position.	Press I or III as needed.	Brief		Brief
	Store the 100% value and allow setting 0%.	Press II to move to the next step.		Brief	
	Adjust output current to 0% position.	Press I or III as needed.	Brief		Brief
	Complete calibration.	Press II to complete calibration.		Brief	
	Abort calibration at any time.	Press I, II and III together briefly.		Brief	Brief
Feedback Calibration	Initiate low level calibration functions.	Hold I, II and III together for 6 seconds.	6s	6s	6s
	Initiate feedback calibration function.	Press I briefly. Then rotate feedback arm all the way around.	Brief		
	Abort calibration at any time.	Press I, II and III together briefly.	Brief	Brief	Brief
Relay Calibration	Initiate low level calibration functions.	Hold I, II and III together for 6 seconds.	6s	6s	6s
	Initiate balance pressure function.	Press II briefly. Wait for settle blink code (YGBB) to clear.		Brief	
	If not in range (RRRO), adjust balance pressure with hex wrench.	Press I briefly. (After adjusting balance pressure.)	Brief		
	If in range (GGGO), end calibration.	Press II briefly.		Brief	
Relay Characterization	Initiate low level calibration functions.	Hold I, II and III together for 6 seconds.	6s	6s	6s
	Initiate relay characterization function.	Press III briefly.			Brief
	End calibration at any time.	Press I, II and III together briefly.	Brief	Brief	Brief
View Software Versions	View S/W version.	Hold I and II together for 3 seconds. (Major SW version will be shown.)	3s	3s	
	View Minor S/W version.	Press III briefly.			Brief
	View Major S/W version.	Press I briefly. (You can toggle back and forth.)	Brief		
	Exit viewing S/W versions.	Press II briefly.		Brief	
Adjust LCD Screen Contrast	Enter contrast adjusting mode.	Hold II and III together for 3 seconds.		3s	3s
	Select higher contrast.	Press I as needed.	As Needed		
	Select lower contrast.	Press III as needed.			As Needed
	Exit contrast adjusting mode.	Press II briefly.		Brief	

F

## APPENDIX G - HOW TO ORDER

Table 21: Spare Parts Kits

Ref.	Description	Part No.
1	Gauge Cover:	
	Gauge Option Cover	361755.999.000
	No-Gauge Option Ex d Cover	361756.999.000
	No-Gauge Option IS Cover	361757.999.000
2	Gauge:	
	Nickel Plated, psi (bar/kPa)	283141.999.000
	Nickel Plated, psi (kg/cm2 )	283228.999.000
	SS, psi (bar/kPa)	291846.999.000
	SS, psi (kg/cm2 )	291847.999.000
	UCC Press Test Plug, 1/8" NPT	017909.999.000
	Valve, Tank, Schrader 645A	002174.999.000
3	Electronics Module:	
	HART, no LCD, no AO	391499.999.000
	HART, LCD and AO	391498.999.000
4	Piezo Assembly	218797.999.000
5	Feedback Assembly:	
	D Shaft KIT, LOGIX 38X	381225.999.000
	Reverse Spring D Shaft KIT, LOGIX 38X	603675.999.000
	NAMUR Shaft KIT LOGIX 38X	381226.999.000
	DD Shaft KIT LOGIX 38X	381227.999.000
	Reverse Spring DD Shaft KIT, LOGIX 38X	603676.999.000
	NAF Shaft KIT LOGIX 38X	381228.999.000
6	Pilot Relay Module:	
	A pilot relay module assembly includes a pilot relay, manifold, gauges, and cover with attaching hardware and gaskets. To order assemblies not listed below, contact your Flowserve representative. Have your positioner model code ready.	
	<ul style="list-style-type: none"> <li>Aluminum manifold</li> <li>¼ NPT port threads</li> <li>Double acting standard relay</li> <li>3 nickel plated gauges, psi (bar/kPa)</li> <li>Right side gauge orientation</li> </ul>	373352.999.000
	<ul style="list-style-type: none"> <li>Aluminum manifold</li> <li>¼ NPT port threads</li> <li>Double acting standard relay</li> <li>3 nickel plated gauges, psi (bar/kPa)</li> <li>Left side gauge orientation</li> </ul>	373353.999.000
	<ul style="list-style-type: none"> <li>Aluminum manifold</li> <li>¼ NPT port threads</li> <li>Single acting standard relay</li> <li>3 nickel plated gauges, psi (bar/kPa)</li> </ul>	603911.999.000
7	Direct Mounting Kit:	
	Alum. IS Housing	373042.999.000
	Alum. Ex d Housing	373043.999.000

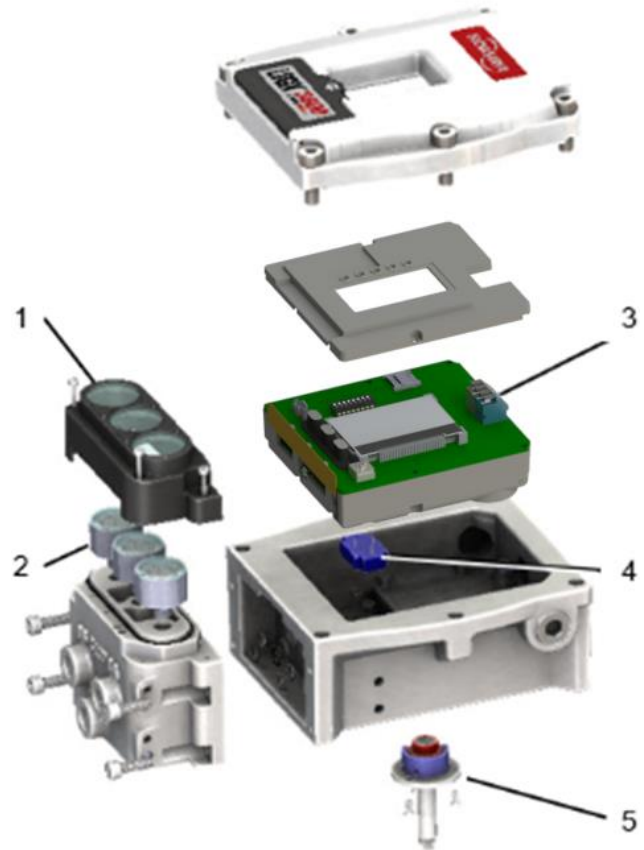

Figure 44: Spare Parts

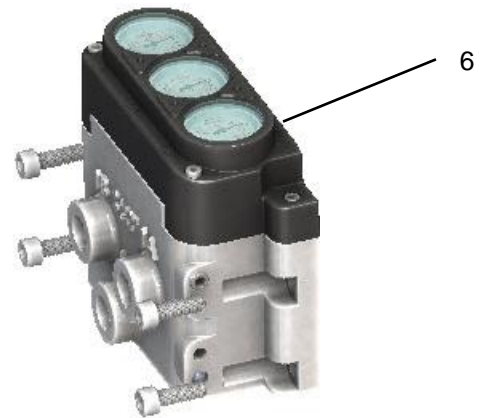

Figure 43: Pilot Relay Module

**Table 22: Linear Actuator Mounting Kits (D Shaft)**

<b>Positioner Mounting Kits, Logix 3800e, Valtek Linear Actuators</b>				
<b>Stainless Steel</b>				
<b>SPUD</b>	<b>Size 25</b>	<b>Size 50</b>	<b>Size 100/20</b>	<b>Size 300/400</b>
<b>2</b>	380558.150.000	380442.150.000		
<b>2.62</b>		381232.150.000	380298.150.000	
<b>2.88</b>			380298.150.000	
<b>3.38</b>			380417.150.000	380424.150.000
<b>4.75</b>			380417.150.000	380424.150.000

Note: mounting kits consist of all bracketing, bolting, stem clamps and stem clamp bolting, etc. required to mount the Logix 3800e positioner. It does not include any actuator parts nor yoke clamps and bolting.

Contact Flowserve for assistance in selected the correct mounting kit.

**Table 23: Logix 3800e Positioner Model Code**

Selection	Description	Code
<b>Base Model</b>	Logix 3800 Series	38
<b>Communication</b>	Analog Only	1
	HART	2
<b>Housing</b>	Aluminum – Aluminum Cover, IS	0
	Aluminum – Ex d	1
	Aluminum – Plastic Cover, IS, (General Purpose Only)	3
<b>Certifications</b>	Brazil-InMetro, Ex db, Ex ia,ib,ic, Ex t, Ex nA, IP66	06
	General Purpose	14
	ATEX / IECEx ,Ex db, Ex ia,ib,ic, Ex t, Ex nA, IP66 <sup>1</sup>	28
	*FM/US/Canada Ex Proof Class I Div 1 Gp B-D (A)Ex db, Ex ec, Dust Ignition Proof Class II,III Gp E-G (A)Ex tb, Intrinsically Safe Class I,II,III Div 1 Gp A-G (A)Ex ia,ib ic, Nonincendive Class I,II,III , Div 2 Gp A-G (A) Ex nA, Type 4x, IP66 <sup>3</sup>	34
	IS Housing Option Only - ATEX / IECEx , Ex ia,ib,ic, Ex t, Ex nA, Ex ec, IP66 FM/US/Canada , Intrinsically Safe Class I,II,III Div 1 Gp A-G (A)Ex ia,ib ic, Nonincendive Class I,II,III , Div 2 Gp A-G (A) Ex nA, Dust Ignition Proof Class II,III Gp E-G (A)Ex tb,Type 4x, IP66 <sup>2</sup>	37
	Plastic cover (Housing Option 3) Only - ATEX / IECEx, Ex ia,ib,ic, IP66 FM/US/Canada, Intrinsically Safe Class I,II,III Div 1 Gp A-G (A)Ex ia,ib ic, Dust Ignition Proof Class II,III Gp E-G (A)Ex tb,Type 4x, IP66 <sup>4</sup>	48
<b>Threaded Connections</b>	Mounting: 5/16" 18 UNC, Pneumatics: 1/4" NPT, Conduit: 1/2" NPT, Vents 1/4" NPT	E
	Mounting: M8 x 1.25, Pneumatics: G1/4", Conduit: M20 x 1.5, Vents G1/4"	G
	Mounting: M8 x 1.25, Pneumatics: 1/4" NPT, Conduit: M20 x 1.5, Vents 1/4" NPT	M
<b>Actuation Medium</b>	Air	A
	Natural Gas	G
<b>Relay Type</b>	Double Acting, Standard	D
	Double Acting, Low Bleed (Natural Gas)	L
	Single Acting, Low Bleed	S
<b>Actuator Action</b>	Three Way, Single Acting	3
	Four Way, Double Acting	4
<b>Pressure Gauges</b>	No Gauges	0
	Nickel Plated with Brass Internals, psi (bar/kPa) Sealed and purged	1
	Nickel Plated with Brass Internals. psi (kg/cm2 ) Sealed and purged	2
	SS with Brass Internals. psi (bar/kPa) Sealed and purged	3
	SS with Brass Internals. psi (kg/cm2 ) Sealed and purged	4
	UCC Press Test Plug, 1/8" NPT	A
Valve, Tank, Schrader 645A	B	
<b>Gauge Orientation</b>	Pneumatic ports, vents and gauges oriented for display on the left side of the positioner	L
	Pneumatic ports, vents and gauges oriented for display on the right side of the positioner	R
<b>Diagnostics</b>	Standard Diagnostics (Standard Functionality)	0
<b>Display/AO</b>	No LCD, No AO	2
	LCD, AO	3
<b>Feedback Shaft</b>	No Feedback Shaft	0
	D - 316 Stainless Steel Shaft	1
	NAMUR - 316 Stainless Steel Shaft (VDI/VDE 3845)	2
	DD - 316 Stainless Steel Shaft (Logix 3200/3400 retrofit mounting)	3
	NAF - 316 Stainless Steel Shaft	4
	DD - 316 Stainless Steel Shaft (Valtek Standard)	5
	D - 316 Stainless Steel Shaft w/ Reverse Spring	6
DD - 316 Stainless Steel Shaft w/Reverse Spring	7	
<b>Mounting</b>	Standard Mounting	0
	Direct Mounting Block	D
	VDI/VDE 3847 Manifold	V
<b>Special Options</b>	No Special Options	00
	Special Options	ZZ

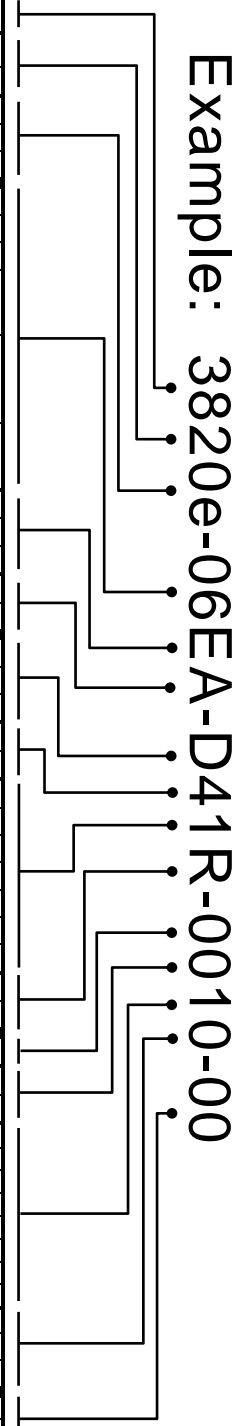

Example: 3820e-06EA-D41R-0010-00

1 For use with either Housing options 0 or 1  
 2 For use only with Housing option 0  
 3 For use only with Housing option 1  
 4 For use only with Housing option 3



**Flowserve Headquarters**  
5215 N. O'Connor Blvd. Suite 2300  
Irving, Tx. 75039  
Phone: +1 972 443 6500

**Flowserve Corporation**  
Flow Control Division  
1350 N. Mt. Springs Parkway  
Springville, UT 84663 USA  
Phone: +1 801 489 8611  
Fax: +1 801 489 3719

**Flowserve Canada Inc.**  
9044 18th Street  
Edmonton, Alberta  
Canada T6P 1K6  
Phone: +1 780 449 4850  
Fax: +1 780 449 4850

**Flowserve (Singapore) Pte Ltd.**  
12 Tuas Avenue 20  
Republic of Singapore 638824  
Phone: +65 6879 8900  
Fax: +65 6862 4940

**Flowserve Australia Pty Ltd.**  
14 Dalmore Drive  
Scoresby, Victoria 3179 Australia  
Phone: +61 397 593 300  
Fax: +61 397 593 301

**Brazil - Flowserve Ltda .**  
Rua Tocantins, 128  
São Caetano do Sul, SP 09580-130  
Brazil  
Phone: +55 11 2169 6300  
Fax: +55 11 2169 6313

**Flowserve (Austria) Control Valves gmbH**  
Control Valves - Villach Operation  
Kaserngasse 6  
Villach, Carinthia Austria A-9500  
Phone: +43 (0)4242 41181 0  
Fax: +43 (0)4242 41181 50

**Flowserve Netherlands**  
Ambachtsstraat 15  
3176 PR Poortugaal  
The Netherlands  
Phone: +31 10 524 1050  
Fax: +31 10 524 1055

**Flowserve (China)**  
No. 35 Baiyu Road  
Suzhou City, Jiangsu  
China, 215021  
Phone: +86 512 6255 2388

**Flowserve India Controls**  
Plot No.4, 1 A, Road No. 8  
Export Promotion Industrial Park (EPIP)  
Whitefield, Bangalore – 560 066  
Karnataka, India  
Phone: +91 80 401 46217  
Fax: +91 80 28 410286 -287

**Flowserve Abahsain (Saudi Arabia) Flow Control Company Ltd.**  
Plot 10 & 12 Phase 4  
2nd Industrial Area  
Dammam Kingdom of Saudi Arabia 31952  
Phone: +966 3 857 3150 X 243  
Fax: +966 3 8574243

**South Africa (Pty.) Ltd;**  
Unit N. 1  
12 Director Road  
Spartan, Ext 2, Kempton Park  
Gauteng, South Africa  
Phone: +27 11 923-7330  
Fax: +27 11 974 6420

**Flowserve Russia/Belorussia**  
2/1, Gamsonovsky Lane  
115191 Moscow, Russia  
Phone: +7 495 781-5977 / 79  
Fax: +7 495 781-5979

To find your local Flowserve representative please use the Sales Support Locator System found at:

- [www.flowserve.com](http://www.flowserve.com)
- [digitalproductstac@flowserve.com](mailto:digitalproductstac@flowserve.com)
- Europe +43 (0) 4242 41181 999
- North America +1 801 489-2300
- Asia + (65) 6879 8900



**Download 3800e Manual**

(Certification information in manual may not be applicable. Valid certifications are found on positioner labels.)

Flowserve Corporation has established industry leadership in the design and manufacture of its products. When properly selected, this Flowserve product is designed to perform its intended function safely during its useful life. However, the purchaser or user of Flowserve products should be aware that Flowserve products might be used in numerous applications under a wide variety of industrial service conditions. Although Flowserve can (and often does) provide general guidelines, it cannot provide specific data and warnings for all possible applications. The purchaser/user must therefore assume the ultimate responsibility for the proper sizing and selection, installation, operation, and maintenance of Flowserve products. The purchaser/user should read and understand the Installation Operation Maintenance (IOM) instructions included with the product, and train its employees and contractors in the safe use of Flowserve products in connection with the specific application.

While the information and specifications contained in this literature are believed to be accurate, they are supplied for informative purposes only and should not be considered certified or as a guarantee of satisfactory results by reliance thereon. Nothing contained herein is to be construed as a warranty or guarantee, express or implied, regarding any matter with respect to this product. Because Flowserve is continually improving and upgrading its product design, the specifications, dimensions and information contained herein are subject to change without notice. Should any question arise concerning these provisions, the purchaser/user should contact Flowserve Corporation at any one of its worldwide operations or offices.

© 2012 Flowserve Corporation, Irving, Texas, USA. Flowserve is a registered trademark of Flowserve Corporation.

For more information about Flowserve Corporation, contact [www.flowserve.com](http://www.flowserve.com) or call USA 1-800-225-6989.