

SIHI[®] UEA
Gas-Handling
Centrifugal Pumps



Design

UEA pumps are horizontal centrifugal pumps of the segmental type with closed impellers and a suction stage. The suction stage is installed on the discharge side. It is arranged in parallel to the last liquid handling stage and operates according to the sucking-through principle.

The design of the UEA has an axial inlet with an NPSH inducer stage. The axial thrust is compensated by single-impeller relief. The remaining axial thrust is compensated by antifriction bearings.

Applications

Gas-handling centrifugal pumps of the UEA series are used for the trouble-free handling of pure or turbid, unaggressive liquids, containing no solids.

The gas-handling capability of UEA pumps is used to handle mainly liquid gas (LPG) and other hydrocarbon liquidate reshipment points and large gas depots, fire extinguishing plants, sprinkling and irrigation plants, emptying of fuel trucks filling of high tanks, and refueling cars.

Centrifugal pumps of the UEA series with special NPSH inducer stage are applied for trouble-free pumping under unfavorable conditions at the suction side. A special priming stage eventually absorbs existing vapor from the suction side. The capability of the pumps in this series to handle liquids at the boiling point allows a wide-ranging application when handling.

- LPG
- Hydrocarbon condensates
- Hydrocarbon-liquefied gases

Technical data

Output	to 220 m ³ /h
Differential pressure	to 20 bar
Speed	to 3600 rpm
Temperature	-40°C to 80°C (-40°F to 176°F)
Casing pressure	PN 40 to size 8000, PN 25 size to 10 000
Shaft sealing	mechanical seal
Flange connections	DIN EN 1092; PN 25 or PN 40 Option: ASME B16.5
Sense of rotation	clockwise, when seen from the drive on the pump
Certification	ATEX 94/9/EG, Ex II 2 G c T4-T5, GOST



Figure 1: SIHI UEA

Construction

Casing pressure

max. 40 bar to size 8000; -40°C to 120°C (-40°F to 248°F)
max. 25 bar to size 10 000; -40°C to 120°C (-40°F to 248°F)
Pressure stages for higher temperatures according to
DIN EN 764-1.

Please note

Technical and safety rules.

Casing pressure = zero delivery head + positive
suction pressure

Position of the branches

Suction flange axially and discharge flange radially upward.

Flanges

At suction and discharge sides, the flanges correspond to
DIN EN 1092, PN 25 and PN 40. Flange design with groove
to DIN EN 1092 or bored to ASME B 16.5 possible.

Hydraulics

Centrifugal hydraulic with special NPSH impeller and gas
priming stage.

Bearings

At suction side, a liquid-surrounded sleeve bearing; at discharge
side, grease-lubricated inclined ball bearings, as per DIN 628.
A grease filling for antifriction bearing is made in the factory.

Sense of rotation

Clockwise when looking at the pump from the drive end.

Shaft sealing

The shaft can be sealed either by single mechanical or by
double mechanical seal.

Special for liquid gas

Designation DNE: Flowserve EUROPAC 610 (balanced,
internal flushed) standard single mechanical seal with throttle
bush for leakage control.

- **Temperature range:** -40°C to 120°C (-40°F to 248°F);
max. 40 bar

Designation RBG: Flowserve EUROPAC 610/610 (balanced,
internal or external flushed), according to API 682 Plan 52 in
tandem arrangement

- **Temperature range:** -40°C to 120°C (-40°F to 248°F);
max. 40 bar

Designation XEY: Burgmann Cartex DE (balanced, external
flushed) double mechanical seal in back-to-back arrangement
according to API 682 Plan 53 (optional Plan 52 for tandem
arrangement)

- **Temperature range:** -40°C to 120°C (-40°F to 248°F);
max. 25 bar

Sectional drawing and nomenclature

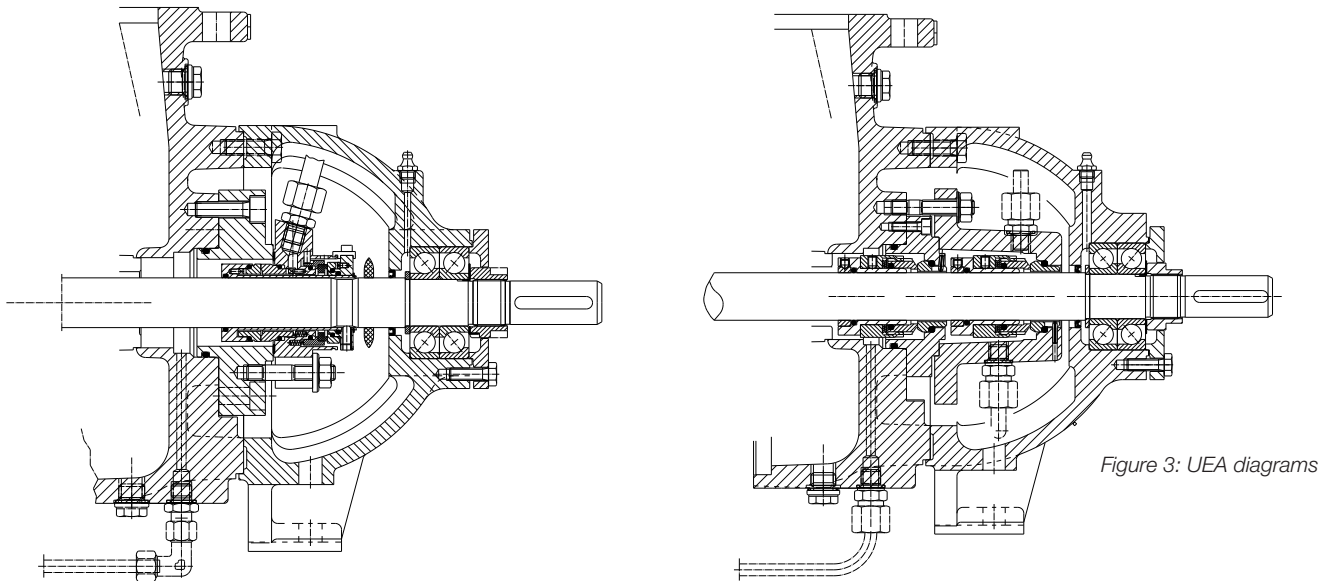
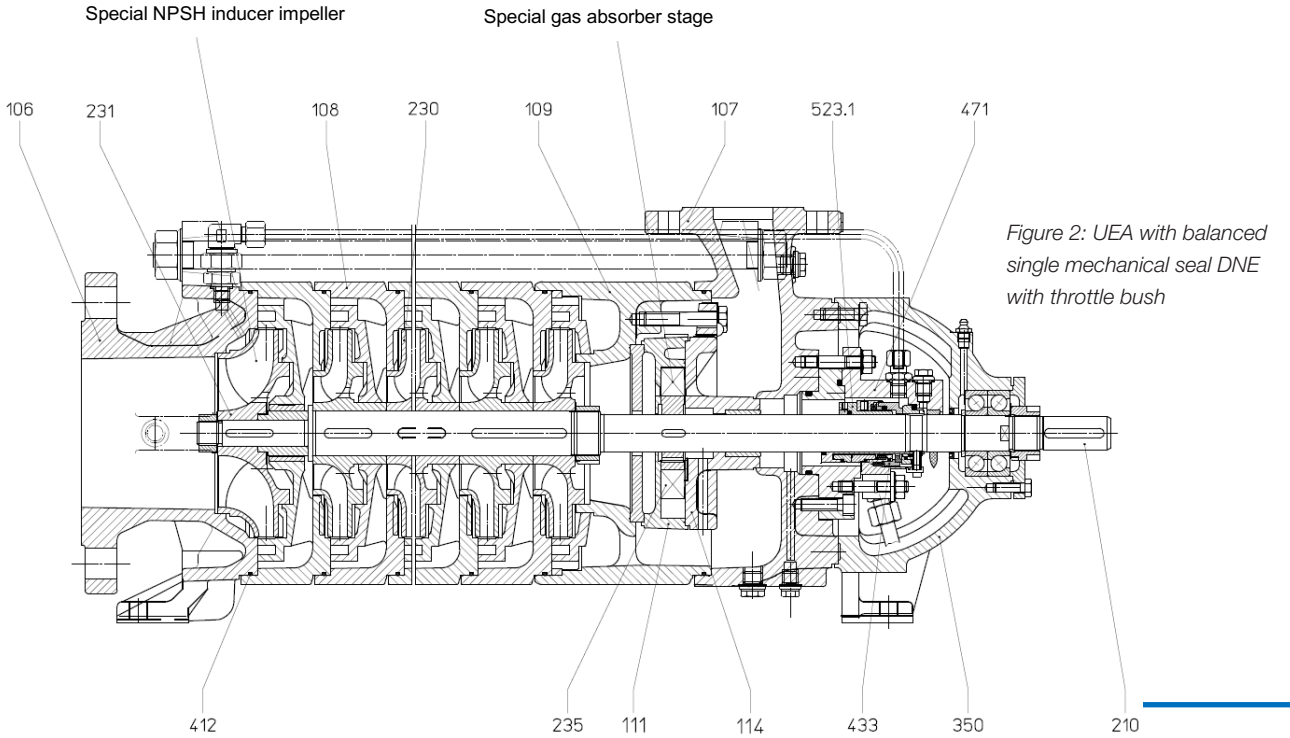

UEA with XEY, Cartex (PN25) double mechanical seal

Arrangement:

Back-to-back API 682 Plan 53 or optional

Tandem API 682 Plan 52

UEA with RBG, (PN40) double mechanical seal

Arrangement:

Tandem API 682 Plan 52

Material design

Item	Components	Material design	
		1A	2C
106	Suction casing	EN-JS1025 - EN 1563 (0.7043)	1.0619 - EN 10213 (GS-C25)
107	Discharge casing		
108	Stage casing		
109	Stage shell		
111	Suction stage (internal)	EN-JL1040 - EN 1561 (0.6025)	
114	Side channel casing		
210	Shaft	1.4122+QT - EN 10088-3	
230	Impeller (internal)	EN-JL2030 - EN 1561 (0.6022)	
231	NPSH impeller	EN-JL2030 - EN 1561 (0.6022)	
235	Vane wheel impeller	CC483K-GS - EN 1982 (2.1052.01)	
350	Bearing casing	EN-JL1040 - EN 1561 (0.6025)	
412	O-ring	NBR 70 (standard)	NBR 70 (standard)
433	Shaft sealing	DNE	Chrome steel/carbon, NBR (SANGG)
		RBG	Chrome steel/carbon, NBR (2 x SANGG)
		XEY	Carbon graphite/SiC, NBR (AQ1PMG-AQ1PMG)
523	Shaft sleeve at mechanical seal	1.4571 - EN 10088-3	

Casing seal

The casing is sealed by NBR O-rings.

Drive/Speed

By commercial electric motors, construction type IM B3.

Observe the following maximum speed dependent on the number of stages:

Series and size	Max. speed	Series and size	Max. speed	Series and size	Max. speed	Series and size	Max. speed
UEA 5002 - 03	3600	UEA 5004 - 10	3000		1800		1500
UEA 6502 - 05		UEA 6506 - 07					
		UEA 8002 - 03		UEA 8004 - 09		UEA 8010 - 13	
				UEA 10 002 - 05		UEA 10 006 - 15	

Size data

Series and size		Speed	Hydraulics and bearings	Shaft sealing	Material design	Flange design	
UEA			<ul style="list-style-type: none"> A• hydraulic A with NPSH impeller 1 8002 - 8003 10 002-10 015 M• hydraulic A with NPSH impeller 1 5002 - 5010 6502 - 6507 •A two grease-lubricated, single-row inclined ball bearings and one liquid-surrounded sleeve bearing 	<p>Specially for liquefied gas</p> <p>DNE Flowserve, balanced standard single mechanical, PN 40, t = -40°C to 120°C (-40°F to 248°F), seal with internal flushing, throttle bush with option to monitor leakage</p> <p>RBG Flowserve balanced double mechanical seal (tandem). PN 40, t = -25°C to 120°C (-25°F to 248°F), seal with internal and external flushing (API 682 Plan 52), option to monitor leakage</p> <p>KEY Burgmann Cartex balanced double mechanical seal in back-to-back or tandem arrangement. Depending of external supplier seal with internal and external flushing with pumping rings PN 25, t = -40°C to 120°C (-40°F to 248°F), seal (API 682 Plan 52 and 53), option to monitor leakage</p>	<p>1A -20°C to 80°C (-4°F to 176°F) cast iron with nodular cast iron EN-JS1025 - EN 1563 (0.7043/ (GGG 40.3)</p> <p>O-ring: NBR 70 (standard)</p> <p>2C -40°C to 80°C (-40°F to 176°F) cast steel 1.0619 - EN 10213/(GS - C25)</p> <p>O-ring: NBR 70 (special -40°C [(-40°F)])</p>	<p>1 flanges acc. DIN</p> <p>F flanges acc. ASME (ANSI)</p>	
	UEA	5002 - 5010	1450	MA	DNE	1A	1
		6502 - 6507		AA	RBG		
		8002 - 8013					
		10 002 - 10 015	2900	MA	KEY	2C	F
		5002 - 5010		AA			
6502 - 6507							
8002 - 8003							

Design	Code	Motor selection table for EEXd					
		motor n = 2900 rpm			motor n = 1450 rpm		
		kW	size	code	kW	size	Code
Pump with free shaft end	01	15	160 M	TA	3	100 L	LB
		18.5	160 L	UA	4	112 M	MB
		22	180 M	VA	5.5	132 S	NB
		30	200 L	XA	7.5	132 M	PB
Pump with coupling, ready drilled at motor side and contact safety device for shaft coupling	41	37	200 L	YA	11	160 M	SB
		45	225 M	AA	15	160 L	UB
As above, but pump and contact safety device for the shaft coupling mounted on baseplate, including shims for pump or motor and one set of rag bolts	53	55	250 M	BA	18.5	180 M	VB
		75	280 S	CA	22	180 L	WB
		90	280 M	DA	30	200 L	XB
As above, but with motor, e.g., 45 kW three-phase AC motor (50 Hz, 400 V), at 1450 rpm	e.g., AB	110	315 S	EA	37	225 S	ZB
		132	315 M	FA	45	225 M	AB
		160	315 M	GA	55	250 M	BB
		75	280 S			280 S	CB
					90	280 M	DB
					110	315 S	EB

Example for ordering:

The size UEA• 8007 AA DNE 1A 1 with coupling, ready drilled at motor side and contact safety device for the shaft coupling has the complete order number:

UEA• 8007 AA DNE 1A 1 41

The size UEA• 8007 AA DNE 1A 1 as complete unit with 45 kW three-phase AC motor, 1450 rpm, has the complete order number:

UEA• 8007 AA DNE 1A 1 AB

On delivery the point (•), in the fourth place of the type design will be replaced by a letter. In case of ordering the designs 41 and 53, please indicate the requested motor, so that the coupling can be ready drilled at motor side, the suitable baseplate can be selected, and the appropriate shims can be attached.

Characteristic curves

$\rho = 0.56 \text{ kg/dm}^3$

$n = 2900 \text{ rpm}$

UEA 5002 - 5005

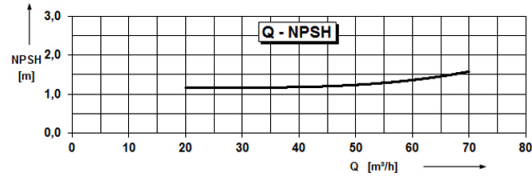
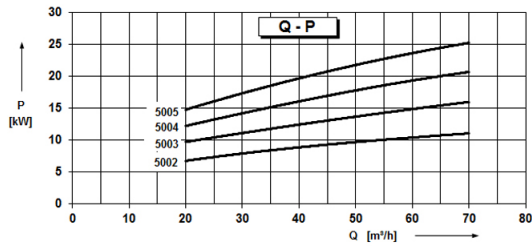
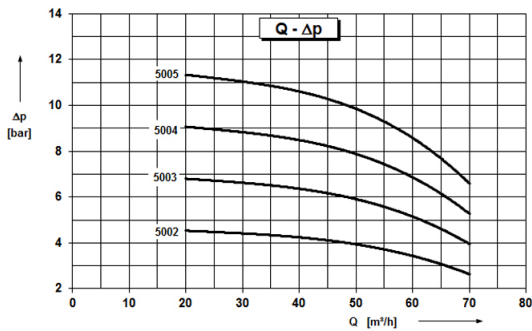

UEA 5006 - 5010

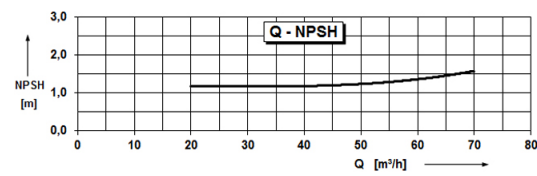
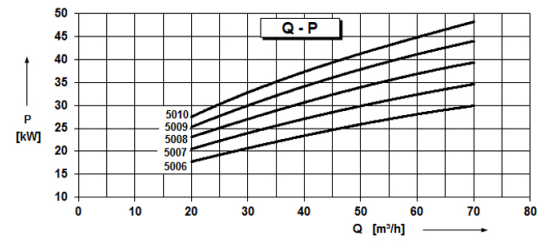
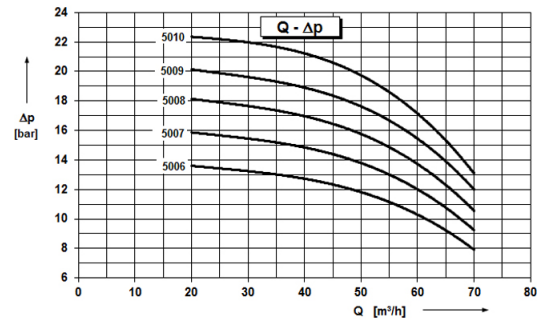

UEA 6502 - 6507

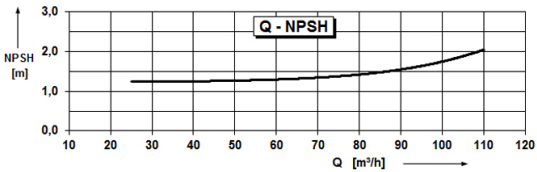
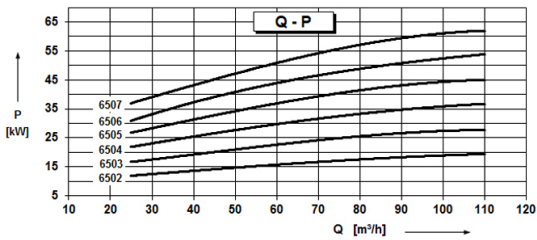
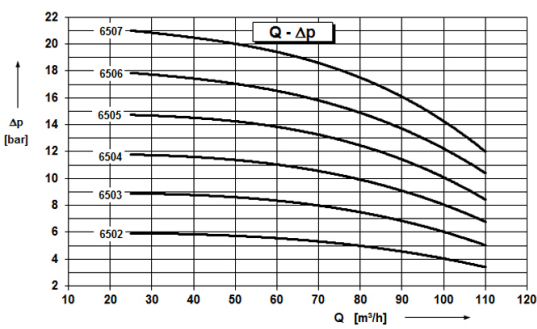

UEA 8002 - 8003

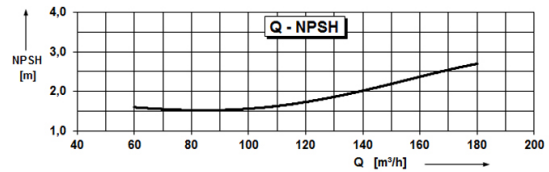
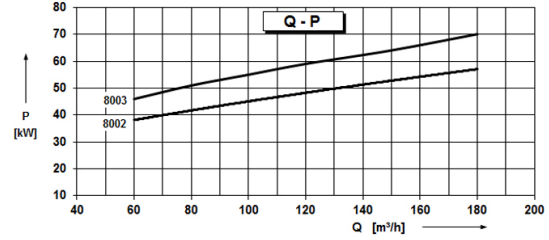
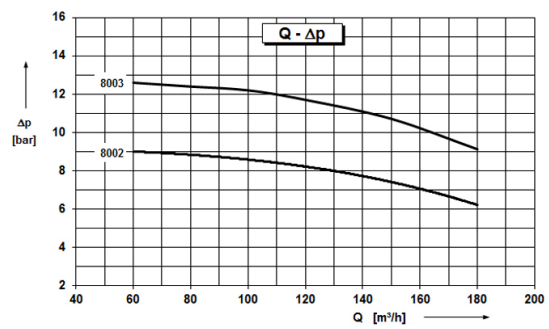

Characteristic curves

 $\rho = 0.56 \text{ kg/dm}^3$
 $n = 1450 \text{ rpm}$

UEA 8002 - 8005

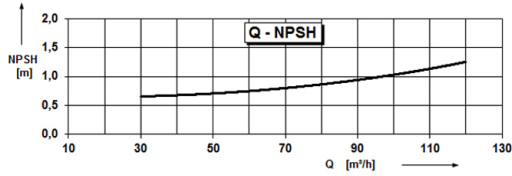
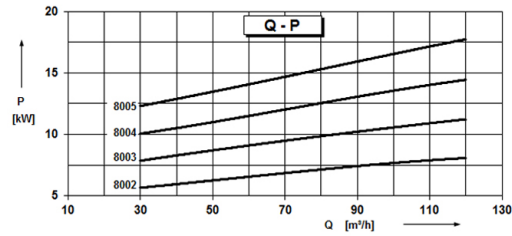
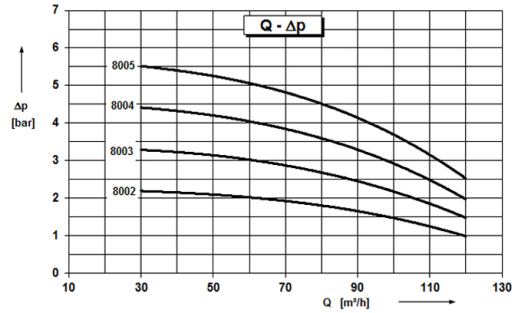

UEA 8006 - 8008

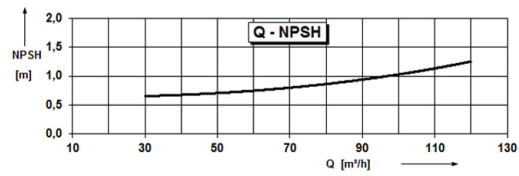
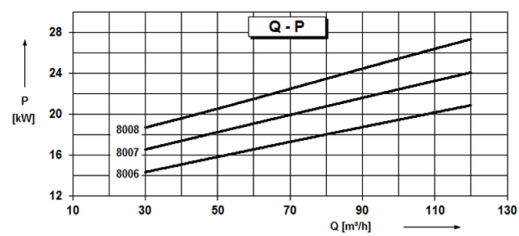
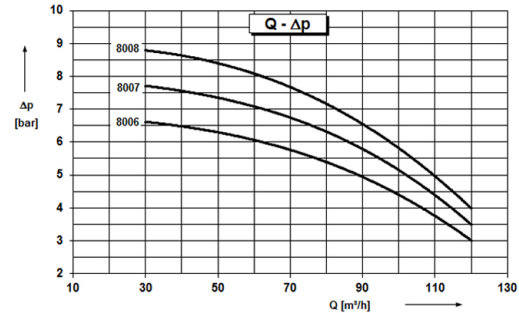

UEA 8009 - 8011

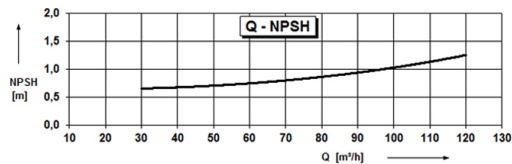
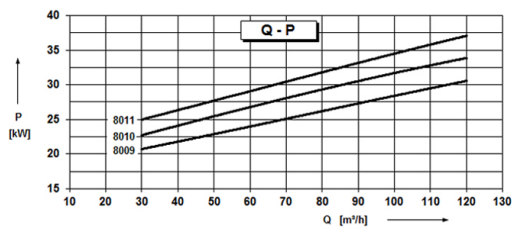
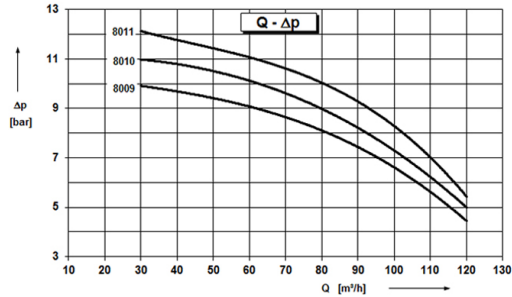

UEA 8012 - 8013

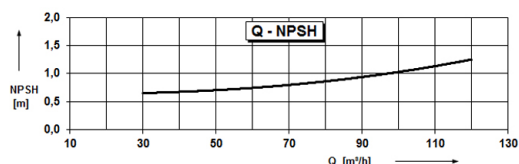
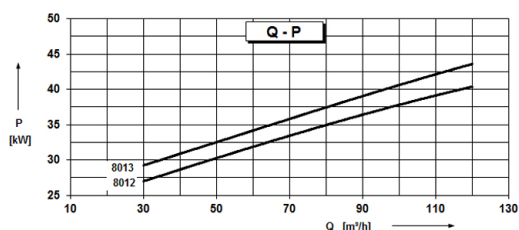
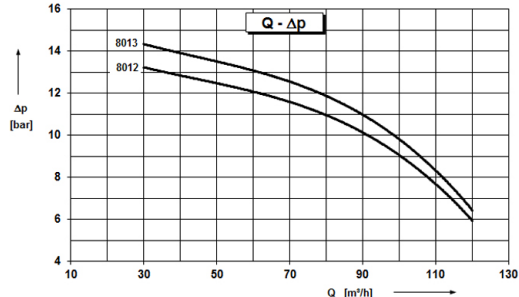

Characteristic curves

$\rho = 0.56 \text{ kg/dm}^3$

$n = 2900 \text{ rpm}$

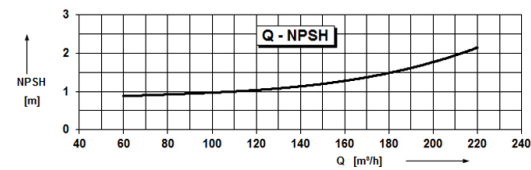
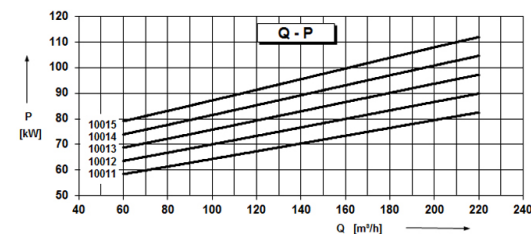
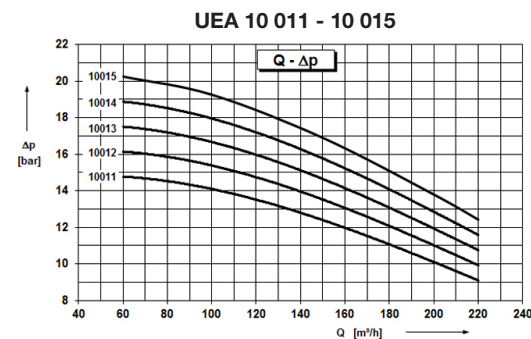
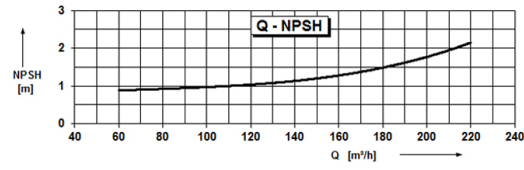
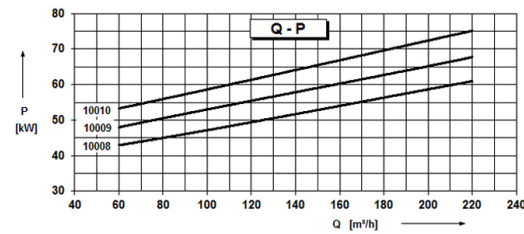
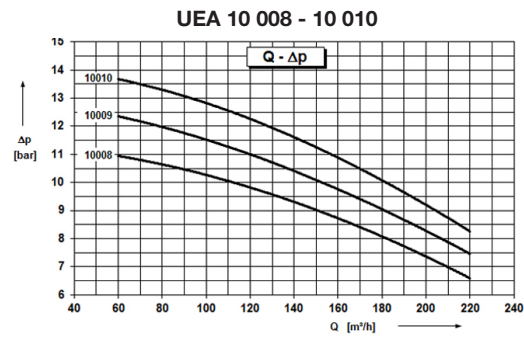
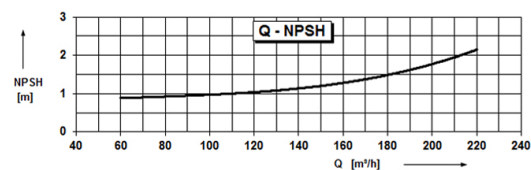
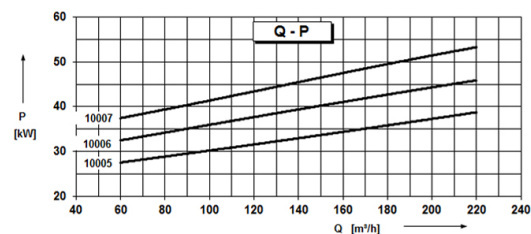
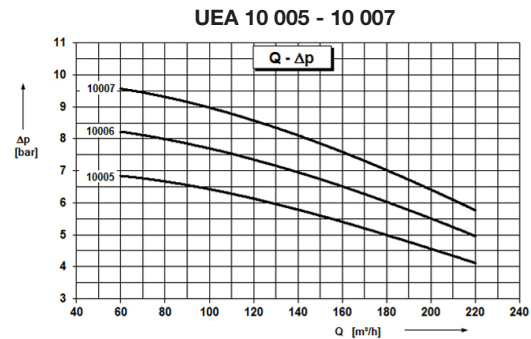
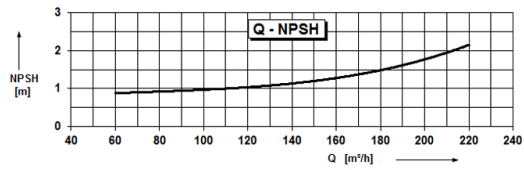
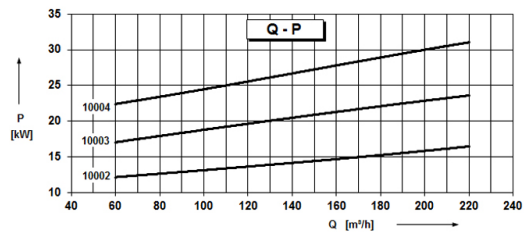
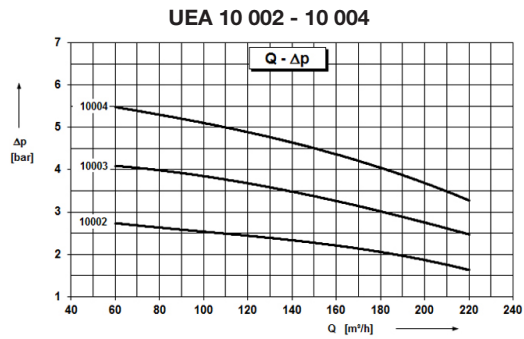

Dimensions

Normal casing pressure: PN 40 for UEA 50 – 80, PN 25 for UEA 100

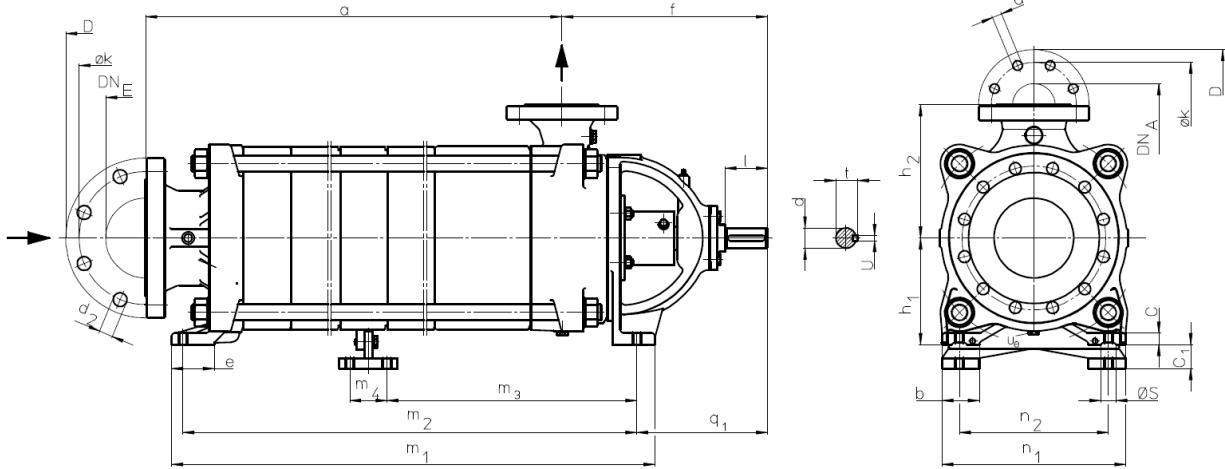

u_6 = connection for drain G3/8, for UEA 10 000 G1/2

u_m = connection for pressure gauge G3/8

Figure 4: UEA diagrams

Size	DN _A	DN _E	b	c	e	f	h ₁	h ₂	n ₁	n ₂	s	q ₁	d _{k6}	l	t	u
5000	50	125	50	18	60	310*	160	190	266	216	15	187*	28	60	31	8
6500	65	125	60	18	70	358	180	215	314	254	15	233	32	80	35	10
8000	80	150	70	22	80	387	200	250	345	280	15	246	38	80	41	10
10 000	100	200	80	25	100	442	250	300	400	318	18	276	42	110	45	12

* UEA 5009 and 5010, f = 357.5, q₁ = 234.5

Size	a	m ₁	m ₂	m ₃	Weight (kg)
5002	371	484	446	-	105
5003	433	546	508	-	119
5004	495	608	570	-	133
5005	557	670	632	-	147
5006	619	732	694	-	161
5007	681	794	756	-	175
5008	743	856	818	-	189
5009	867	980	942	525	217
5010	929	1042	1004	587	231
6502	444	550	510	-	139
6503	519	625	585	-	160
6504	594	700	660	-	181
6505	669	775	735	-	202
6506	744	850	810	-	223
6507	819	925	885	-	244
8002	512	638	583	-	191
8003	602	728	673	-	221
8004	692	818	763	-	251
8005	782	908	853	-	281
8006	872	998	943	-	311
8007	962	1088	1033	-	341
8008	1052	1178	1123	-	371
8009	1142	1268	1213	-	401
8010	1322	1448	1393	739.5	455
8011	1412	1538	1483	739.5	485
8012	1502	1628	1573	829.5	515
8013	1592	1718	1663	919.5	545

Size	a	m ₁	m ₂	m ₃	Weight (kg)
10 002	581	728	650	-	289
10 003	691	838	760	-	337
10 004	801	948	870	-	385
10 005	911	1058	980	-	433
10 006	1021	1168	1090	-	481
10 007	1131	1278	1200	-	529
10 008	1241	1388	1310	-	577
10 009	1351	1498	1420	-	625
10 010	1571	1718	1640	889	710
10 011	1681	1828	1750	889	758
10 012	1791	1938	1860	999	806
10 013	1901	2048	1970	1109	854
10 014	2011	2158	2080	999	902
10 015	2121	2268	2190	1219	950

m₃: 70 mm (only for size 80)

Flange connections to DIN EN 1092						
PN 40						
DN _{A/E}	50	65	80	100	125	150
D	165	185	200	235	270	300
k	125	145	160	190	220	250
d ₂ x quan.	18 x 4	18 x 8	18 x 8	22 x 8	26 x 8	26 x 8
PN 25						
DN _{A/E}	100	200				
D	235	360				
k	190	310				
d ₂ x quan.	22 x 8	26 x 12				

Dimensions

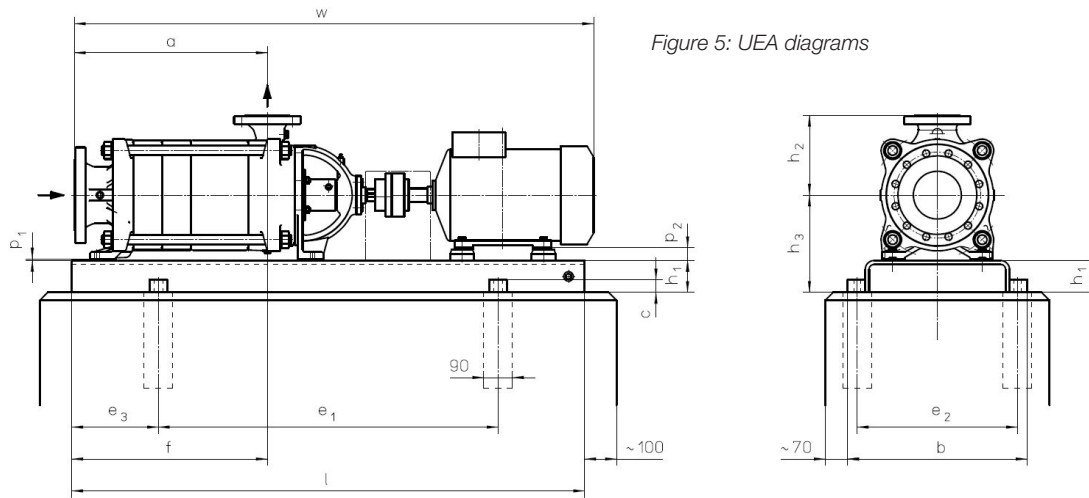

Pump size	Motor		a	b	c	e ₁	e ₂	e ₃	f	h ₁	h ₂	h ₃	l	p ₁	p ₂	w	Rag bolt	Weight (kg)				
	kW	Size																				
5002	15	160M	371	540	30	840	490	215	381	80	190	245	1270	5	5	1275	M20x250	289				
5003	18.5	160L	433	610	35	940	550	240	443	100	190	265	1420	5	5	1337	M24x400	413				
	22	180M										295		25		1467		426				
5004	18.5	160L	495	610	35	940	550	240	505	100	190	265	1420	5	5	1439	M24x400	426				
	22	180M										295		25		1529		440				
	30	200L										305		1600		45	5	1584	M24x400	502		
5005	30	200L	557	560	40	1060	500	270	567	100	190	305	1620	45	5	1646	M24x400	516				
	45	225M		660	35		600	280				70		1676		638						
5006	22	180M	619	560	40	1060	500	270	629	100	190	285	1600	25	5	1653	M24x400	453				
	30	200L										305		45		1708		530				
	37	200L										330		70		1738	550					
	45	225M										330		1620		70	5	1738	M24x400	652		
5007	30	200L	681	560	40	1200	500	300	691	100	190	305	1800	45	5	1770	M24x400	555				
	37	200L																330	1820	70	1800	575
	45	225M																330	1820	70	1800	696
5008	45	225M	743	730	40	1200	670	310	753	100	190	330	1820	70	5	1862	M24x400	711				
5009	55	250M	867	740	40	2x700	690	300	877	100	190	355	2000	95	5	2159	M24x400	843				
6502	22	180M	444	610	35	940	550	240	454	100	215	285	1420	5	5	1526	M24x400	437				
6503	30	200L	519	660	35	1060	600	280	529	100	215	305	1620	25	5	1656	M24x400	554				
6504	30	200L	594	660	35	1060	600	280	604	100	215	305	1620	25	5	1731	M24x400	575				
	45	225M		740	40		1200	690				270		330		1600		50	1761	686		
	55	250M		740	40	1200	690	300				355		1800		75		1886	792			
6505	45	225M	669	740	40	1200	690	300	679	100	215	330	1800	50	5	1836	M24x400	749				
	55	250M										355		75		1961		813				
6506	55	250M	744	740	40	2x700	690	300	754	100	215	355	2000	75	5	2036	M24x400	856				
6507	75	280S	819	740	40	2x700	690	300	829	100	215	390	2000	110	10	2186	M24x400	1084				
8002	15	160L	512	610	35	940	550	240	512	100	250	305	1420	5	45	1532	M24x400	421				
	75	280S		740	40	1200	690	300	522			385		1800	85	5		1911	1013			
8003	15	160L	602	560	40	1060	500	270	612	100	250	305	1600	5	45	1622	M24x400	442				
	75	280S		740	40	2x700	690	300				385		2000	85	5		1998	1075			
	90	280M		740	40	2x700	690	300				385		2000	85	5	1998	1105				
8004	15,5	180M	692	560	40	1200	500	300	702	100	250	305	1800	5	25	1802	M24x400	554				
	22	180L																579				
8005	22	180L	782	560	40	1200	500	300	792	100	250	305	1800	5	25	1892	M24x400	609				
8006	30	200L	872	740	40	2x700	690	300	882	100	250	305	2000	5	5	2037	M24x400	782				
8007	30	200L	962	740	40	2x700	690	300	972	100	250	305	2000	5	5	2127	M24x400	812				
8008	37	225S	1052	740	40	2x750	690	370	1062	100	250	330	2240	30	5	2282	M24x400	964				
8009	37	225S	1142	740	40	2x750	690	370	1152	100	250	330	2240	30	5	2372	M24x400	964				
	45	225M																994				
	55	250M																2x830	420	355	2500	55
8010	45	225M	1322	740	40	2x830	690	420	1242	100	250	355	2500	55	5	2555	M24x400	1264				
8011	45	225M	1412	740	40	2x830	690	420	1332	100	250	355	2500	55	5	2645	M24x400	1294				

Dimension table

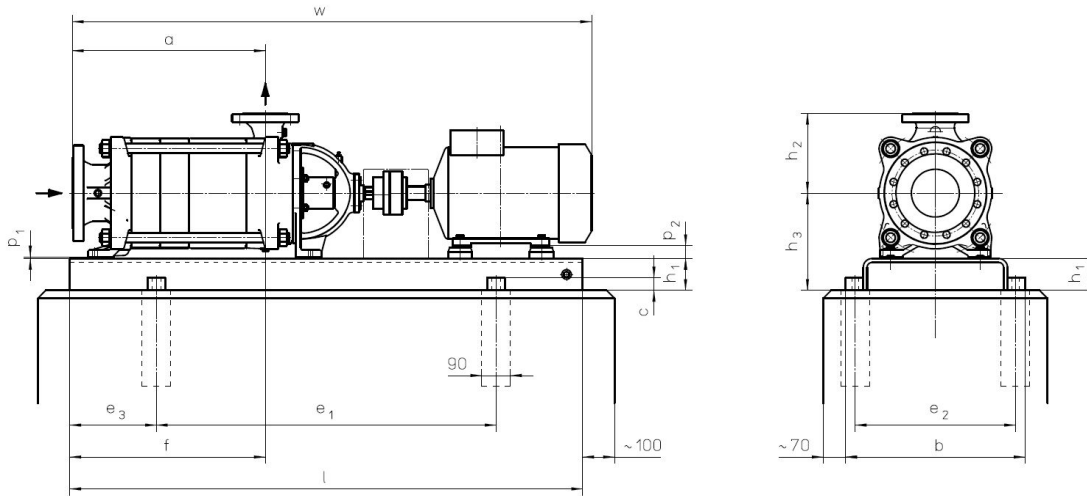

Figure 6: UEA diagrams

Pump size	Motor		a	b	c	e ₁	e ₂	e ₃	f	h ₁	h ₂	h ₃	l	p ₁	p ₂	w	Rag bolt	Weight (kg)
	kW	Size																
10 002	22	180M	581	560	40	1200	500	300	591	100	300	355	1800	5	75	1747	M24x400	608
10 003	30	200L	691	560	40	1200	500	300	701	100	300	355	1800	5	55	1906	M24x400	709
	45	225M		740		2x700	690						2000		30	1972		891
10 004	37	225S	801	740	40	2x700	690	300	811	100	300	355	2000	5	30	2082	M24x400	939
	45	225M																969
10 005	45	225M	911	740	40	2x700	690	350	921	100	300	355	2100	5	30	2192	M24x400	1003
10 006	45	225M	1021	740	40	2x750	690	370	1031	100	300	355	2240	5	30	2302	M24x400	1065
	55	250M													2397	1206		
	75	280S													2472	1408		
10 007	55	250M	1131	740	40	2x830	690	420	1141	100	300	355	2500	5	5	2507	M24x400	1329
	75	280S										385		35	2582	1531		
10 008	75	280S	1241	740	40	2x830	690	420	1251	100	300	385	2500	35	5	2692	M24x400	1529
	90	280M																1579

Other designs are available on request.

Any changes in the interest of the technical development are reserved.



Flowserve Corporation
5215 North O'Connor Blvd.
Suite 2300
Irving, Texas 75039-5421 USA
Telephone: +1 937 890 5839

Flowserve Corporation has established industry leadership in the design and manufacture of its products. When properly selected, this Flowserve product is designed to perform its intended function safely during its useful life. However, the purchaser or user of Flowserve products should be aware that Flowserve products might be used in numerous applications under a wide variety of industrial service conditions. Although Flowserve can provide general guidelines, it cannot provide specific data and warnings for all possible applications. The purchaser/user must therefore assume the ultimate responsibility for the proper sizing and selection, installation, operation, and maintenance of Flowserve products. The purchaser/user should read and understand the Installation Instructions included with the product, and train its employees and contractors in the safe use of Flowserve products in connection with the specific application.

While the information and specifications contained in this literature are believed to be accurate, they are supplied for informative purposes only and should not be considered certified or as a guarantee of satisfactory results by reliance thereon. Nothing contained herein is to be construed as a warranty or guarantee, express or implied, regarding any matter with respect to this product. Because Flowserve is continually improving and upgrading its product design, the specifications, dimensions and information contained herein are subject to change without notice. Should any question arise concerning these provisions, the purchaser/user should contact Flowserve Corporation at any one of its worldwide operations or offices.

©2019 Flowserve Corporation. All rights reserved. This document contains registered and unregistered trademarks of Flowserve Corporation. Other company, product, or service names may be trademarks or service marks of their respective companies.

PSS-120-2.3b (AQ) June 2019