

### Energy recovery device for desalination applications

Energy is generally the most significant cost driver in any seawater reverse osmosis (SWRO) desalination facility. Energy recovery devices, such as the DWEER Dual Work Exchanger Energy Recovery unit, play a crucial role in reducing energy use and costs.

The DWEER device can recover up to 98% of the energy in the high-pressure brine waste stream — making it the most efficient energy recovery device available. Desalination plants can use recovered energy to pressurize feed water, reducing the size of the high-pressure (HP) pump and the energy input needed for HP feed pumps by about 55%.

With the DWEER isobaric device, the HP pump does not have to be connected to the energy recovery device. This permits plants to use fewer, but larger, more efficient pumps.

#### Features and benefits

**Best-in-class mixing and leakage value** — are key elements for the most efficient energy recovery technology available today.

**Wide operating range and increased capacity** — translate into unmatched operational flexibility and extremely high availability and reliability.

**Wide operating range** — enables plants to accommodate normal fluctuations in demand easily.

**LinX™ valve and actuators** — offer precise control of the energy transfer mechanism as well as the operating speed of the system.

**Robust design with extremely low maintenance costs** — support high availability and 25-year service life and contribute to low total cost of ownership.

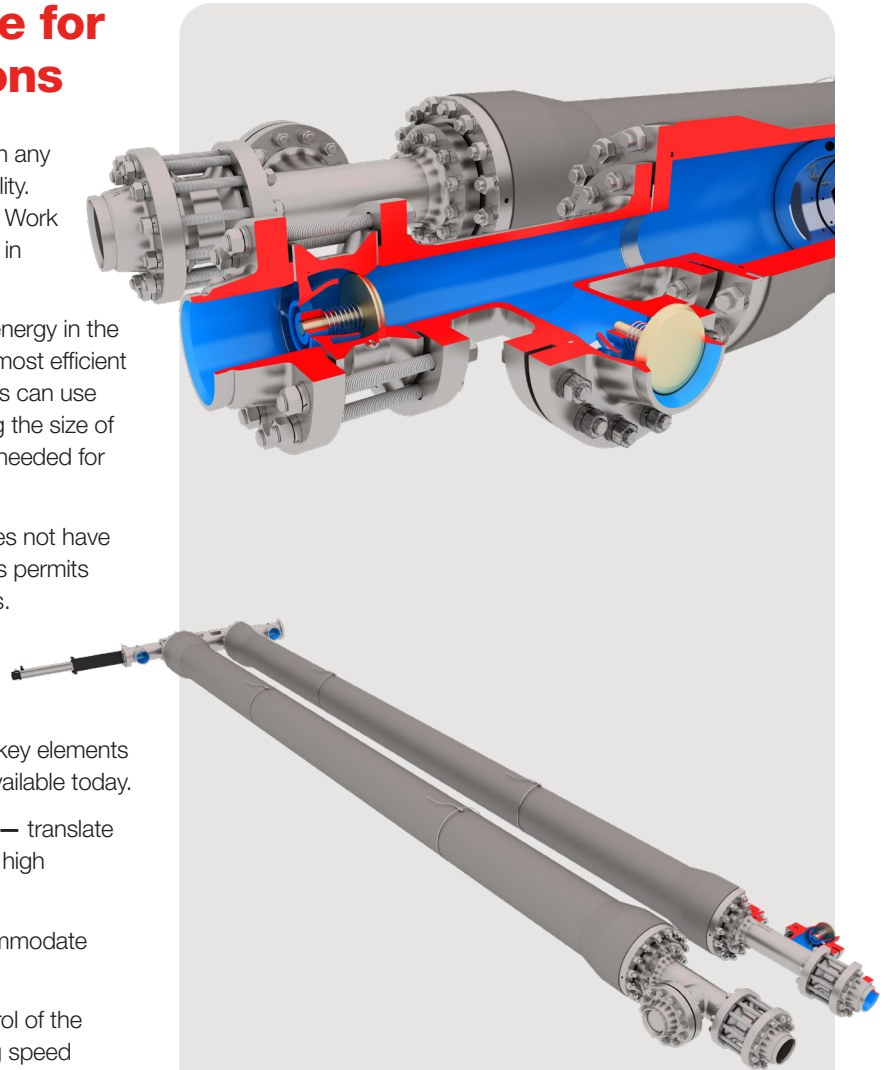

## How it works

The high-pressure brine from the membranes is directed to a DWEER work exchanger vessel that is pre-filled with low-pressure (LP) feed water. The work exchanger vessel pressurizes the feed water with the brine pressure.

A small recirculation pump equalizes the pressure of the HP feed water leaving the work exchanger, overcoming membrane and system losses. The seawater then joins the flow from the high-pressure pump to form the high-pressure membrane feed flow.

As the end of this half-cycle nears, a valve diverts the high-pressure brine to the opposite work exchanger vessel. This vessel makes an LP stroke at the same time as the other vessel makes its HP stroke. The LP stroke is fed by the low-pressure seawater (from the same source feeding the high-pressure pump), which fills the work exchanger vessel with feed water displacing the brine to discharge, and the cycle repeats.

## Available model

- DWEER 1550

## Operating parameters

- Brine flows to 350 m<sup>3</sup>/h (1,550 gpm); greater flows can be achieved by placing multiple DWEER units in parallel
- Pressures to 83 bar (1,200 psi), depending on model material requirements
- Slow-moving equipment with below 5 cpm for the LinX valve to divert HP brine to the vessel in HP use
- Noise level < 80 dba for standard configuration



Flowserve Corporation  
5215 North O'Connor Blvd.  
Suite 2300  
Irving, Texas 75039-5421 USA  
Telephone: +1 937 890 5839

Flowserve Corporation has established industry leadership in the design and manufacture of its products. When properly selected, this Flowserve product is designed to perform its intended function safely during its useful life. However, the purchaser or user of Flowserve products should be aware that Flowserve products might be used in numerous applications under a wide variety of industrial service conditions. Although Flowserve can provide general guidelines, it cannot provide specific data and warnings for all possible applications. The purchaser/user must therefore assume the ultimate responsibility for the proper sizing and selection, installation, operation, and maintenance of Flowserve products. The purchaser/user should read and understand the Installation Instructions included with the product, and train its employees and contractors in the safe use of Flowserve products in connection with the specific application.

While the information and specifications contained in this literature are believed to be accurate, they are supplied for informative purposes only and should not be considered certified or as a guarantee of satisfactory results by reliance thereon. Nothing contained herein is to be construed as a warranty or guarantee, express or implied, regarding any matter with respect to this product. Because Flowserve is continually improving and upgrading its product design, the specifications, dimensions and information contained herein are subject to change without notice. Should any question arise concerning these provisions, the purchaser/user should contact Flowserve Corporation at any one of its worldwide operations or offices.

©2020 Flowserve Corporation. All rights reserved. This document contains registered and unregistered trademarks of Flowserve Corporation. Other company, product, or service names may be trademarks or service marks of their respective companies.

PUFLY000137 (EN/AQ) March 2020