



# USER INSTRUCTIONS

## Limitorque MX Electronic Actuator

THT/SMT/MXa to MXb Conversion

AIOM000150-00 08/20

**Controls**

**Upgrade**

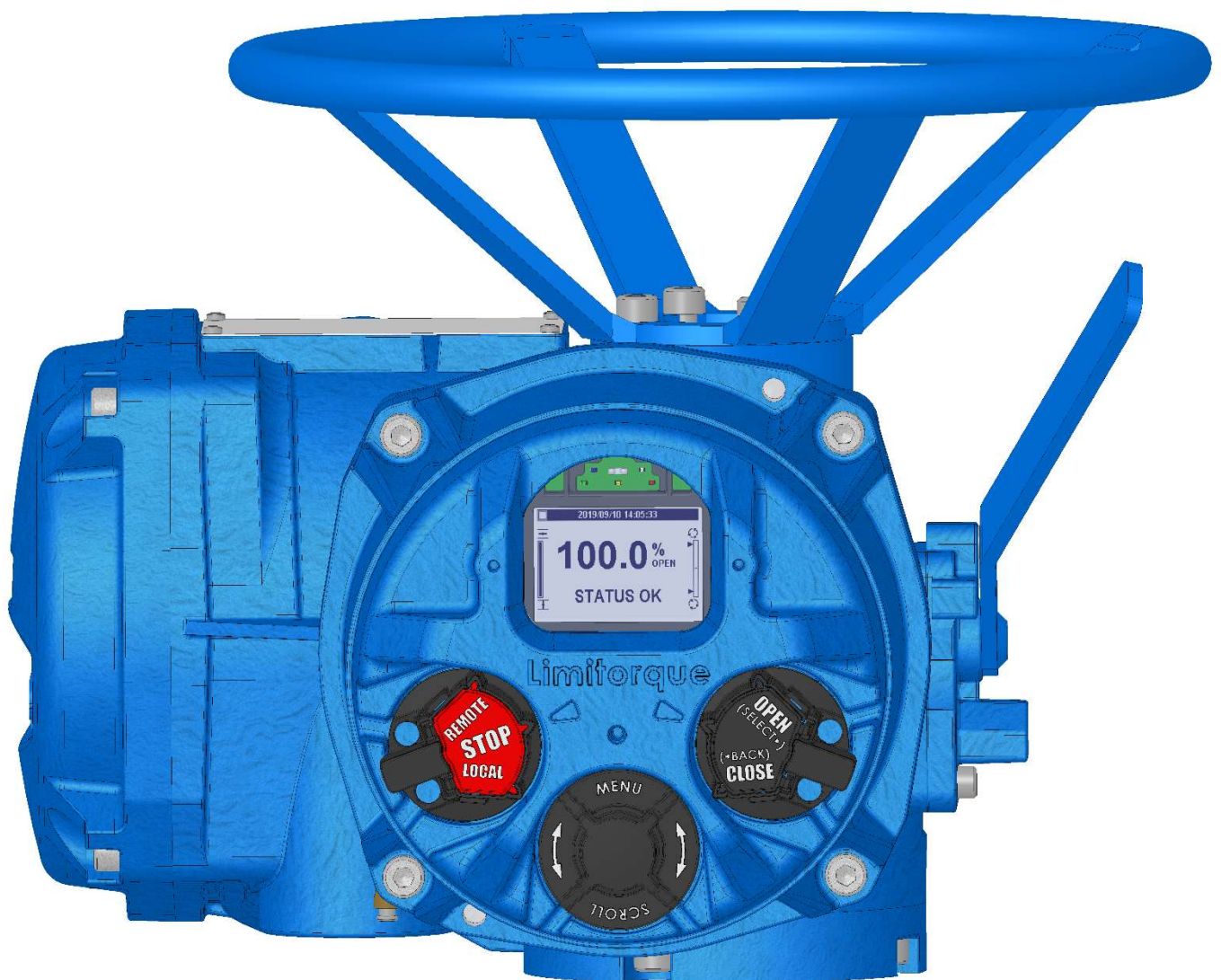



# Table of Contents

|  |    |
|--|----|
| 1 CONVERSION NOTES .....   | 3  |
| 2 INCLUDED IN KIT .....  | 4  |
| 3 REMOVING COMPONENTS .....  | 5  |
| 3.1 REMOVAL OF CONTROLS MODULE .....                                       | 5  |
| 3.1.1 REMOVAL OF THROUGH HOLE CONTROL MODULE .....                         | 5  |
| 3.1.2 REMOVAL OF SMT (SURFACE MOUNT TECHNOLOGY) CONTROLS .....             | 8  |
| 3.1.3 REMOVAL OF MXA CONTROLS (MOST UNITS SUPPLIED AFTER SEPT. 2007) ..... | 9  |
| 3.2 REMOVAL OF TERMINAL BLOCK .....  | 11 |
| 3.2.1 REMOVAL OF 51-POINT TERMINAL BLOCK .....                             | 11 |
| 3.3 REMOVAL OF CONTACTOR MODULE .....                                      | 13 |
| 3.3.1 REMOVAL OF 12 AMP REVERSER .....                                     | 13 |
| 3.3.2 REMOVAL OF 19 AMP REVERSER ON THE MX-140 AND -150 .....              | 14 |
| 3.4 REMOVAL OF ENCODER .....   | 15 |
| 3.5 REMOVAL OF ENCODER DRIVE CARTRIDGE .....                               | 17 |
| 4 INSTALLING COMPONENTS .....  | 18 |
| 4.1 MXB ENCODER DRIVE CARTRIDGE INSTALLATION .....                         | 18 |
| 4.2 INSTALLATION OF MXB ENCODER .....                                      | 19 |
| 4.3 INSTALLATION OF MXB MOTOR LEADS AND TERMINAL BLOCK .....               | 19 |
| 3.4 INSTALLATION OF POWER BOARD .....                                      | 22 |
| 3.4.1 INSTALLING 12A POWER BOARD .....                                     | 22 |
| 3.4.2 INSTALLING 19A POWER BOARD .....                                     | 23 |
| 3.4.3 INSTALLING SSMR POWER BOARD .....                                    | 24 |
| 3.5 INSTALLATION OF MXB CONTROLS .....                                     | 25 |
| 3.6 INITIALIZE AND COMMISSION OF MXB .....                                 | 28 |

# 1 Conversion Notes

- Please read this manual in its entirety before attempting to install or operate your MX actuator. A full understanding of the installation and operation options will assist you in installing the actuator in the most effective manner.
- Disconnect all incoming power before opening any cover on the actuator. The user/operator must ensure that safe working practices are employed at all times and are in accordance with local or national standards that are enforced at the particular site. The conversion is required to be completed in dry conditions.
- Limitorque has designed the MX actuator for long life even in the harshest environments. Flexible control and protection options are provided to ensure the actuator meets your requirements.
- All actuator enclosures are sealed by O-rings, and cable entries are supplied with threaded plugs to protect the terminal compartment until the unit is wired. If the actuator cannot be installed immediately, it is recommended that it be stored in a clean, dry place, preferably in an area that is not subject to large fluctuations in temperature.
- After the conversion, to commission the actuator only the terminal compartment cover needs to be removed. Settings for commissioning the actuator are done externally; therefore, no other covers need to be removed. The actuator was assembled in dry conditions and the total sealing of the enclosure protects all electrical components against deterioration.
- During final installation, ensure that all cable entries are correctly sealed in accordance with National Standards or Regulatory Authorities. All temporary transit plugs must be removed and any unused cable entries closed in an approved manner. Refer to Installation manual VAIOM000071 for complete instructions for MXb.
- For MXa units built prior to 2012. The encoder and power board should be replaced due to changes to ribbon cable connectors and improvements to power board.
- For the different conversion options, the table below outlines which sections of components will require removal and installation.

|                   | MX                                 |                                   | MXa                    |                         |
|-------------------|------------------------------------|-----------------------------------|------------------------|-------------------------|
|                   | Thru-Hole<br>(prior to Sept. 2003) | Surface Mount<br>(2003 and after) | MXa<br>(prior to 2012) | MXa<br>(2012 and after) |
| Controls Cover    | ✓                                  | ✓                                 | ✓                      | ✓                       |
| Host Controller   | ✓                                  | ✓                                 | ✓                      | ✓                       |
| Terminal Block    | ✓                                  | ✓                                 |                        |                         |
| Contactormodule   | ✓                                  | ✓                                 | ✓                      |                         |
| Encoder           | ✓                                  | ✓                                 | ✓                      |                         |
| Encoder Cartridge | ✓                                  | ✓                                 |                        |                         |

\*Removal and Installation Step Requirements Table



# 2 Included in Kit







Each MXa to MXb kit comes with listed below minimum. Kit may include an encoder and power board depending on age of MXa unit.

- MXb Host Controller Assembly
- MXb Controls Cover
- End User Bag
- MXb IOM
- Name Plate Adder
- Blister Pack (Shown to Right)

Converting from older original MX unit will also include at a minimum.

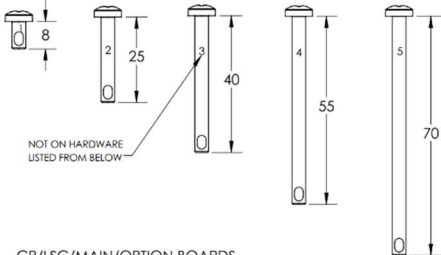
- Encoder Cartridge
- Terminal Block
- Terminal Block Legend
- Encoder
- Power Board

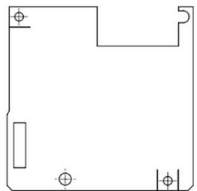
Additional hardware and components such as option boards and optional transformer may be included depending on options ordered.

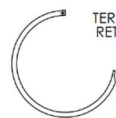
|   |  |   |
|---|--|---|
| <p>PC# 14-8, 1-36, 8-7 or 1-45, 10<br/>Quantity 9</p>  <p>NOTE 1: PC# 8-7 IS SOMETIMES LABELED AS PC# 1-45</p> <p>ENCODER CARTRIDGE HARDWARE<br/>1 X HCF-M4X10 PC# 14-8<br/>ENCODER HARDWARE<br/>3 X HCF-M4X10 PC# 1-36<br/>CONTROL CHASSIS HARDWARE<br/>3 X HCF-M4X10 PC# 8-7 OR 1-45<br/>OPTIONAL TRANSFORMER HARDWARE<br/>2 X HCF-M4X10 PC#10</p> | <p>PC# 1-20<br/>Quantity 1</p>  <p>TERMINAL BLOCK O-RING<br/>CMA-M110X3.5</p> | <p>PC# 7-27<br/>or<br/>PC# 1-46<br/>Quantity 4</p>  <p>ACP COVER HARDWARE<br/>HCB-M8X45<br/>OR<br/>HCM-M8X45</p> <p>NOTE 2: PC# 7-27 IS SOMETIMES LABELED AS PC# 1-46</p>  |
| <p>PC# 8-25 or 7-44<br/>Quantity 4 each<br/>M4 Screws (MM)</p>  <p>NOT ON HARDWARE LISTED FROM BELOW</p> <p>CP/LSC/MAIN/OPTION BOARDS HARDWARE<br/>1. 64-818-0001-35<br/>2. 64-818-0001-32<br/>3. 64-818-0001-36<br/>4. 64-818-0004-3<br/>5. 64-818-0005-3</p>  |  | <p>PC# 1-25<br/>Quantity 2</p>  <p>NAMEPLATE ADDER HARDWARE<br/>HAD3-M3X5</p>  |
| <p>PC# 8-24-1<br/>Quantity 1</p>  <p>OPTION BD. SHIELD<br/>64-663-0008-2</p>   |  | <p>PC# 1-56<br/>Quantity 3</p>  <p>SSMR WASHER<br/>102463</p> <p>PC# 1-21<br/>Quantity 1</p>  <p>TERMINAL BLOCK RETAINING RING<br/>100709</p> <p>MXb Blister Pack<br/>01-602-1394-0<br/>01-602-1395-0<br/>26100-333</p> |

# 3 Removing Components

## 3.1 Removal of Controls Module

This section describes the removal of the controls modules depending on the actuator the user is starting with.

- 3.1.1– Through Hole Controls Module (most units supplied before September 2003)
- 3.1.2– Surface Mount Technology (SMT) (most units supplied after September 2003 and before September 2007)
- 3.1.3– MXa (most units supplied after September 2007)

### 3.1.1 Removal of Through Hole Control Module (Most units supplied prior to Sept. 2003)

**WARNING: Hazardous Voltage! Turn off all power sources to actuator before removing control module assembly. Power sources may include main power or control power.**

**CAUTION:** Potential to cause electrostatic damage to electronic components. Before handling electronic components, ensure that you are discharged of static electricity by briefly touching a grounded metal object.

#### STEP 1

Using a 6mm hex key, remove the quantity 4 M8 fasteners (30mm length) securing the controls cover piece.

**Discard these fasteners** as longer (45mm) fasteners are required to secure the control cover during MXb assembly.

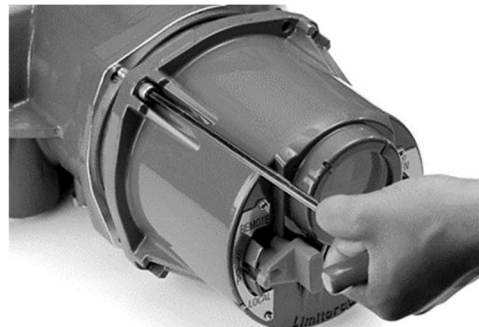

#### STEP 2

If the I/O option board is installed, disconnect wire harness plugs.

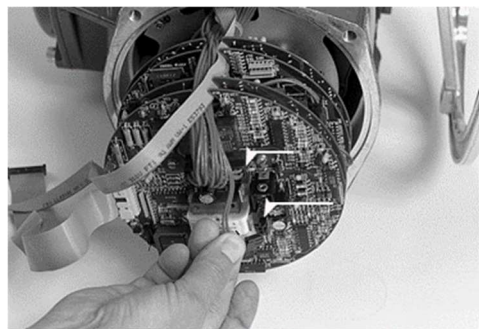

**STEP 3**

If DDC board is installed, disconnect wire harness.

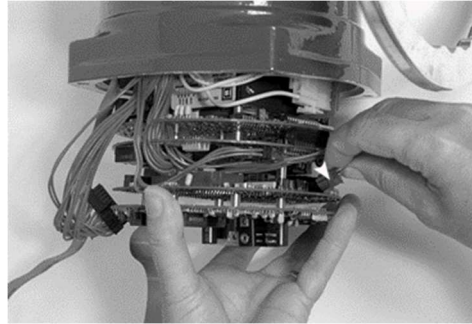

**STEP 4**

Disconnect wire harness plugs from the main processor board.

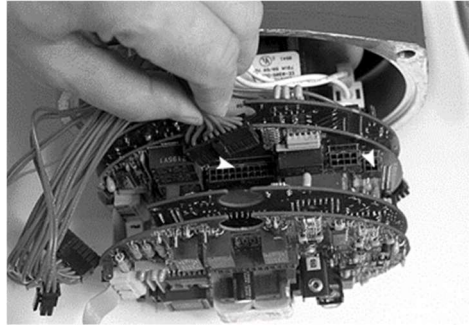

**STEP 5**

Disconnect wire harness plugs from the main power board.

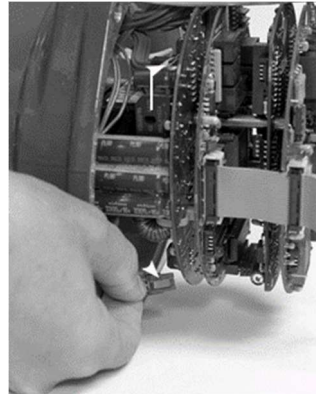

**STEP 6**

Using a 3 mm hex key, loosen the three M4 mounting plate screws located at the back of the controls compartment. Slightly rotate the complete control module assembly in a counterclockwise (CCW) direction, until the keyhole slots in the baseplate allow the heads of the screws to pass through.

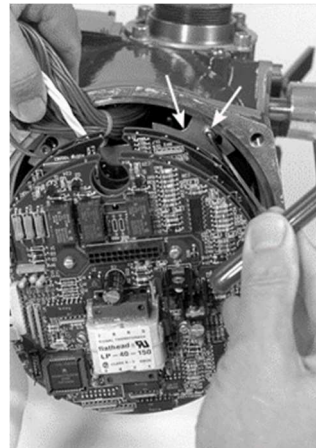

## STEP 7

Disconnect the AMP® power connector from the fuse section of the main power board.

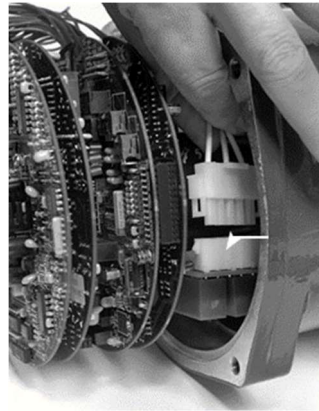

## STEP 8

Remove the control module assembly from actuator housing (leave 20-pin ribbon cable connected to control module boards). Take control module assembly to work area to perform maintenance as required.

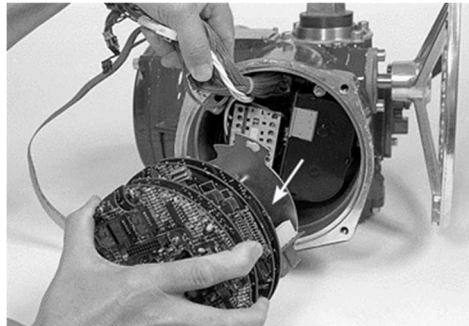

## STEP 9

Using a 3 mm hex key, remove the four M4 screws that retain the main board inside the controls cover.

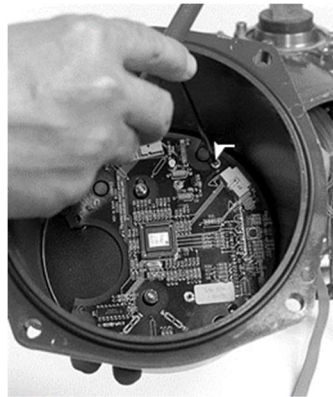

## STEP 10

Lift the main board out of the controls cover.

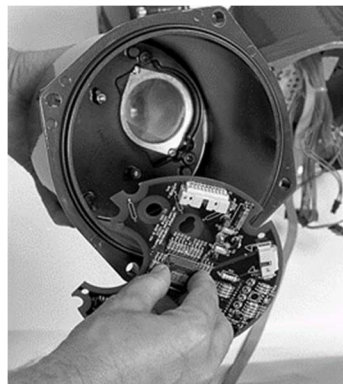

**STEP 11**

Discard the older version of the Control cover (extended knobs).

**NOTE:** Printed circuit boards should be discarded properly.

Please take care to ensure they are discarded in accordance with environmental laws in the specific country where the actuators are installed.

**NOTE:** Skip to section 2.2 on page 10

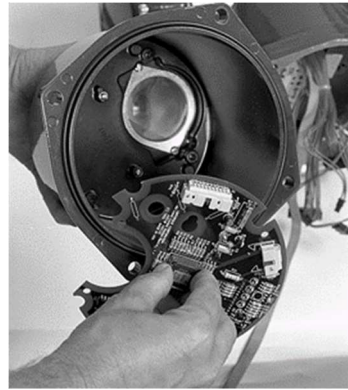

### 3.1.2 Removal of SMT (Surface Mount Technology) Controls (Most units supplied between Sept. 2003 and Sept. 2007)

**WARNING: Hazardous Voltage!** Turn off all power sources to actuator before removing control module assembly. Power sources may include main power or control power.

**CAUTION:** Potential to cause electrostatic damage to electronic components. Before handling electronic components, ensure that you are discharged of static electricity by briefly touching a grounded metal object.

**STEP 1**

Using a 6mm hex key, remove the quantity 4 M8 fasteners (30mm length) securing the controls cover piece. **Discard these fasteners** as longer (45mm) fasteners are required to secure the control cover during MXb assembly.

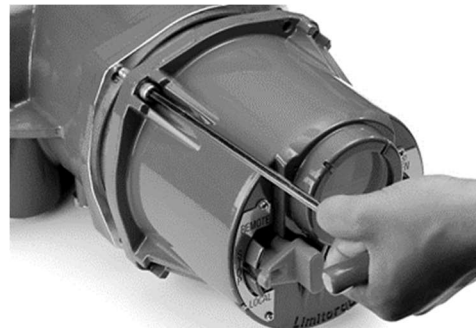

**STEP 2**

**CAUTION:** Potential to pinch cables. When removing controls cover, take special care not to pinch the ribbon cables.





**STEP 3**

Using a Phillips screwdriver, remove the four M4 screws retaining the LCS/Main board inside the CP cover. Remove and discard the old style protruding knob control cover.

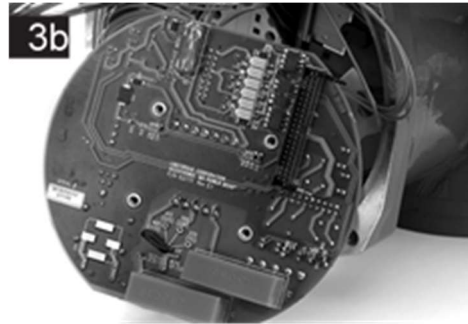

**STEP 4**

Disconnect all ribbon cables and interconnects as necessary from printed circuit boards. Loosen the three (3) power assembly screws, and rotate the controls assembly counter-clockwise (CCW) to remove them.

**NOTE:** Skip to section 2.2 on page 10

### 3.1.3 Removal of MXa Controls (Most units supplied after Sept. 2007)

**WARNING: Hazardous Voltage! Turn off all power sources to actuator before removing control module assembly. Power sources may include main power or control power.**

**CAUTION:** Potential to cause electrostatic damage to electronic components. Before handling electronic components, ensure that you are discharged of static electricity by briefly touching a grounded metal object.

**STEP 1**

Using a 6mm hex key, remove the 4 M8 fasteners (30mm length) securing the controls cover piece. **Discard these fasteners** as longer (45mm) fasteners are required to secure the control cover during MXb assembly.

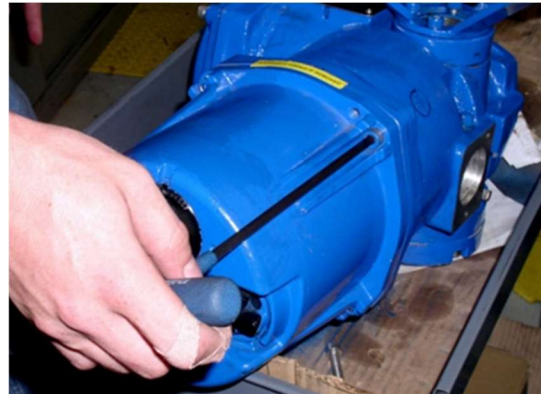

**STEP 2**

Remove the control cover piece from the housing and support control cover near housing. Take care to protect the cables and wires attached to the inside of the assembly.

**STEP 3**

Using a 3mm hex key, remove the four M4 diameter fasteners that mount the PC board stack to the inside of the control cover. Separate the control cover from the PC board stack. Discard the control cover as this will be replaced during MXb assembly

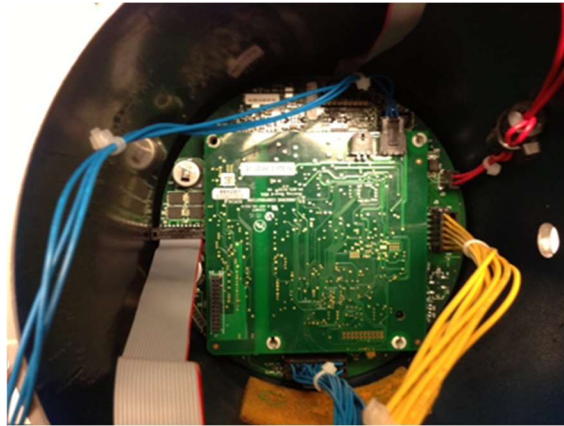

**STEP 4**

After removing the PC board stack from the inside of the controls cover start unplugging all connectors and option PC boards at the MXa main PC board. Remove the square option board stack if present from the round PC board and retain for the MXb assembly. After removing the square option board stack remove all the connectors at the square option PC boards and the MXa main board. There are 5 to 6 connectors depending on the number of options at the round main PC board. Additional connectors may need to be removed at the square option PC boards. Discard the round main PC board as this is going to be replaced during MXb assembly.

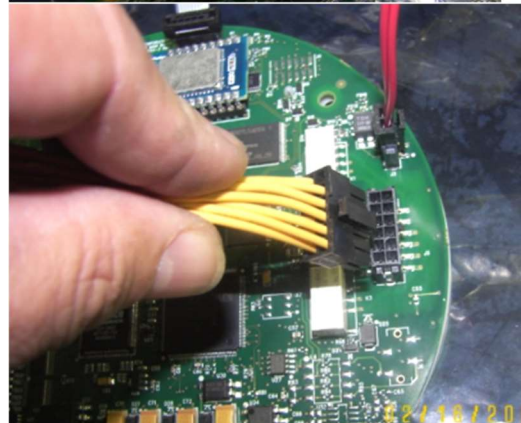
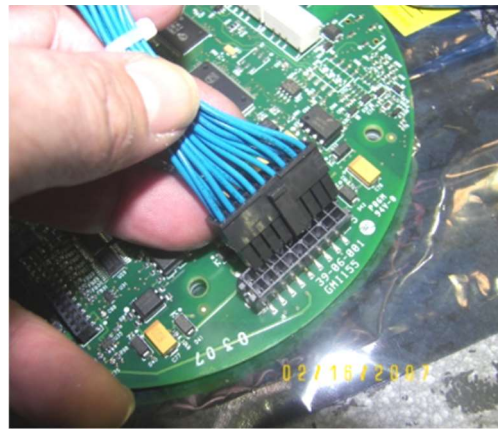

**NOTE:** Skip to section 3.5 on page 25

## 3.2 Removal of Terminal Block

### 3.2.1 Removal of 51-Point Terminal Block

(Most units shipped prior to March 2007)

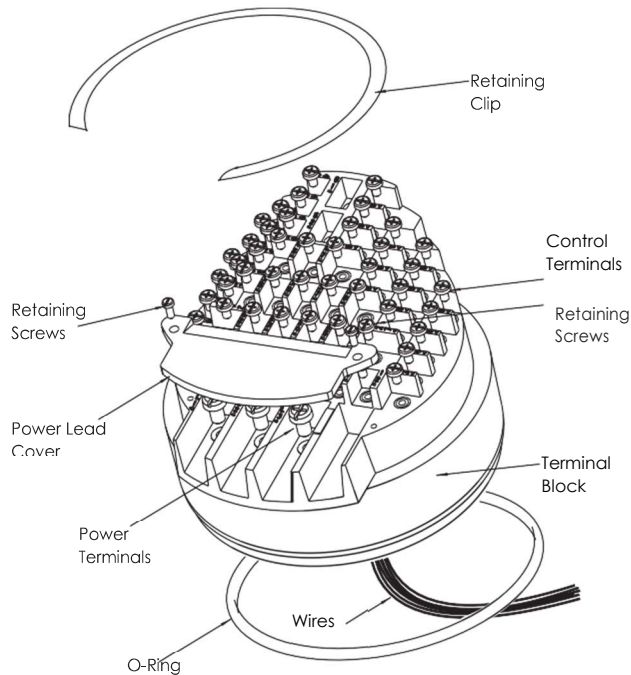

**CAUTION:** Potential to cause electrostatic damage to electronic components. Before handling electronic components, ensure that you are discharged of static electricity by briefly touching a grounded, metal object.

**First Remove:**

1. Control panel and module. (See Section 2.1)

**STEP 1**

Using a 6mm hex key, remove the four M8 screws that mount the terminal compartment cover to the actuator



## STEP 2

If actuator is already in service, disconnect incoming power leads L1, L2, and L3 (and control wiring from the terminal block.

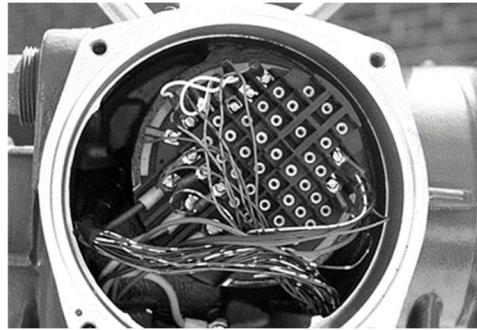

## STEP 3

Using a flat head screwdriver, insert the screwdriver blade underneath the edge of the snap ring and work the blade around the back of the snap ring to remove it from the groove, thus allowing terminal block removal.

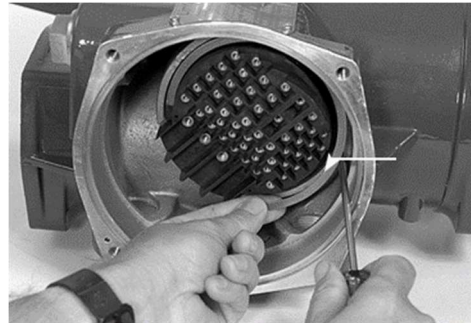

## STEP 4

Remove the terminal block assembly.

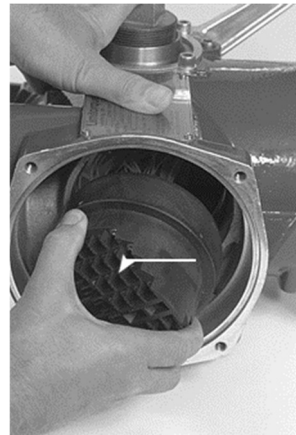

## STEP 5

Disconnect leads L1, L2, and L3 from the back of the terminal block.



**STEP 6**

Feed the terminal block harness plugs over the contactor assembly (in the control module compartment) while removing the terminal block from the terminal block compartment.

**NOTE:** An O-ring is included with the terminal block assembly. Ensure you replace the O-ring at remounting.

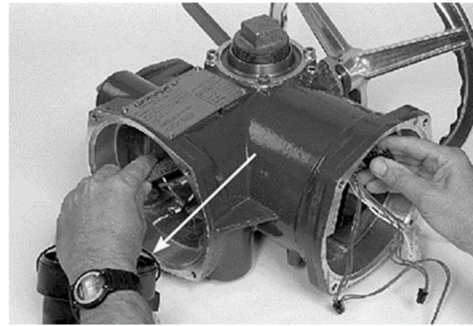

### 3.3 Removal of Contactor Module

**First Remove:**

1. Remove motor.
2. Remove controls cover and module. (See Section 2.1.)
3. Remove terminal block. (See Section 2.2.)

#### 3.3.1 Removal of 12 Amp Reverser

**STEP 1**

Loosen then M4 screws and lift contactor assembly until the keyhole slots in the contactor mounting plate allow the heads of the M4 screws to pass through.

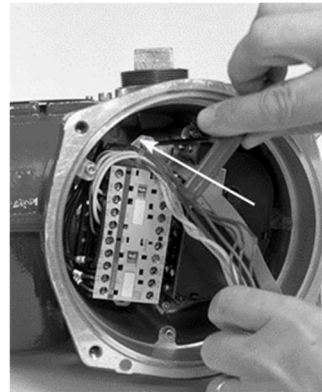

**STEP 2**

Remove the contactor assembly while threading the motor lead harness out of the motor compartment.

**NOTE:** Only the MX-05, -10, -20 and -40 have the long motor lead harness.

**MX-85, -140, AND -150**

Disconnect connectors 4 and 5 to motor lead harness.

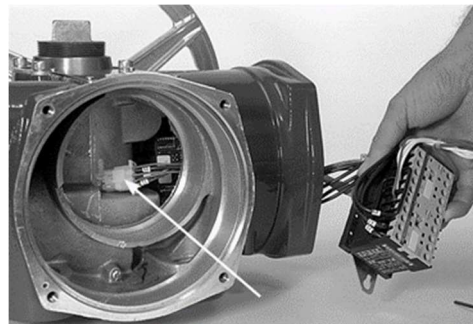

**NOTE:** Skip to section 2.4 on page 14

### 3.3.2 Removal of 19 Amp Reverser on the MX-140 and -150

#### (Most actuators shipped before Sept. 2007)

##### STEP 1

Remove control cover and disconnect the encoder and controls package. Remove controls package from MX housing.

##### STEP 2

Remove terminal cover, retaining ring, terminal block and O-ring to access the back of the terminal block.

##### STEP 3

Disconnect black, blue and brown wires (L1, L2 and L3) from back of terminal block.

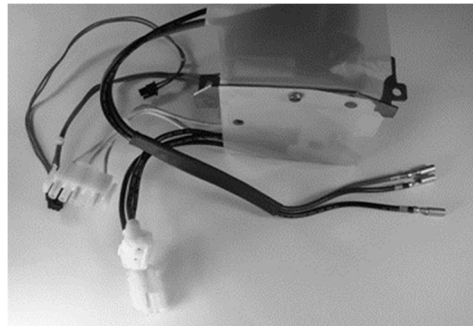

##### STEP 4

Disconnect the lead seal from the reverser by unplugging the 2-pin and single-pin white connectors.

##### STEP 5

Disconnect and remove the encoder mounting screws and the encoder.

##### STEP 6

Remove the mounting screws for the reverser package and remove the reverser by moving the reverser towards the space previously occupied by the encoder. Discard the used reverser package.

### 3.4 Removal of Encoder

(Through hole and surface mount technology; most units supplied prior to Sept. 2007)

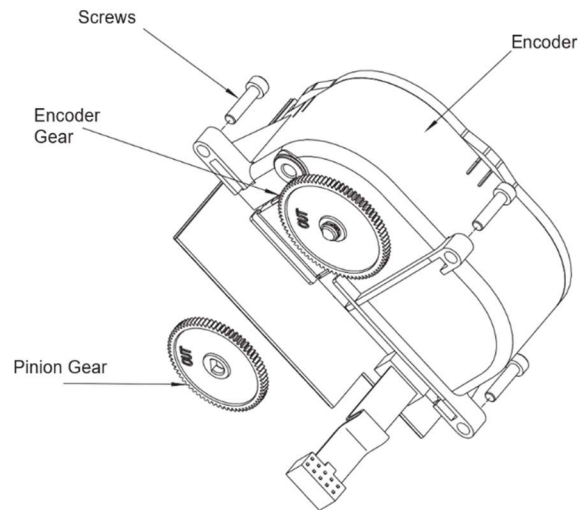

**NOTE: Before removal:**

**CAUTION:** Potential to cause electrostatic damage to electronic components. Before handling electronic components, ensure that you are discharged of static electricity by briefly touching a grounded metal object.

1. Remove motor.
2. Remove controls cover and module. (See Section 2.1.)
3. Remove terminal block. (See Section 2.2.)
4. Remove contactor module (See Section 2.3.)

**NOTE:** The encoder is a sealed assembly of high-precision components and not suitable for repair. Should the encoder fail, it will be necessary to install a factory replacement.

**WARNING: Hazardous Voltage! Turn off all power sources to actuator before removing encoder assembly. Power sources may include main power or control power.**

**CAUTION:** To avoid accidental oil leakage when removing encoder screws, be careful not to remove the encoder cartridge mounting screw. The encoder cartridge screw is located near one of the encoder mounting screws. Accidentally removing the encoder cartridge mounting screw could cause oil leakage into the control compartment.

**STEP 1**

Remove the encoder by locating and removing the three M4 screws that mount the encoder to the actuator housing. Use a 3 mm hex key to remove the screws.

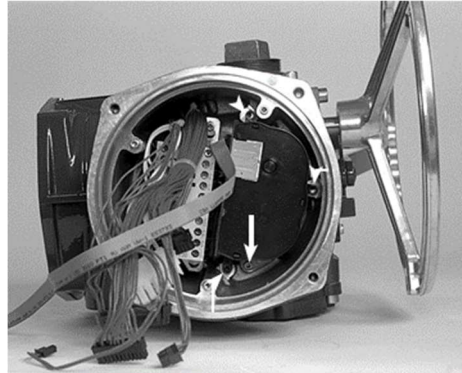
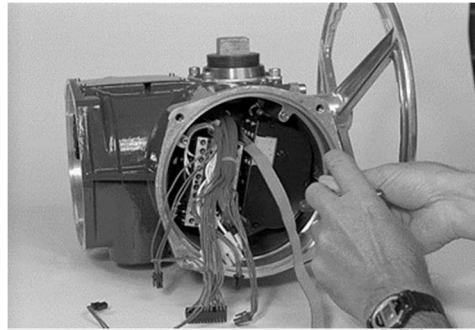

**STEP 2**

Pull the complete encoder straight out of the mounting holes to disengage the gear drive from the encoder drive cartridge pinion

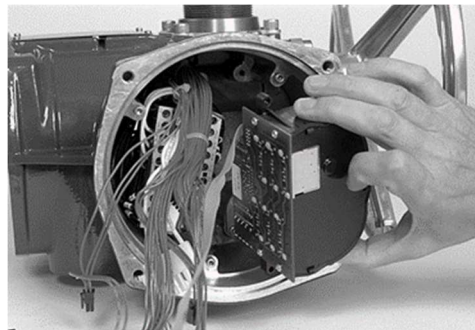



## 3.5 Removal of Encoder Drive Cartridge (Most units supplied prior to Sept 2007)

**NOTE: Before removal:**

1. Drain oil.
2. Remove the controls cover and module. (See Section 2.1)
3. Remove the encoder. (See Section 2.4)

**WARNING: Hazardous Voltage! Turn off all power sources to actuator before removing encoder drive cartridge. Power sources may include main power or control power.**

**STEP 1**

Remove the M4 screw using a 3 mm hex key.

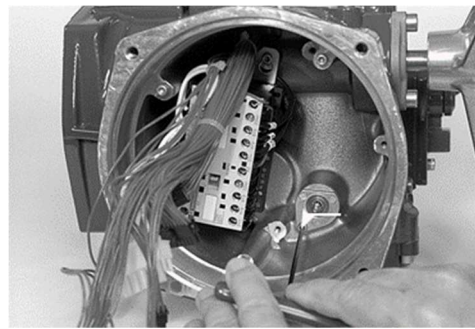

**STEP 2**

Withdraw the complete encoder drive cartridge from the actuator housing.

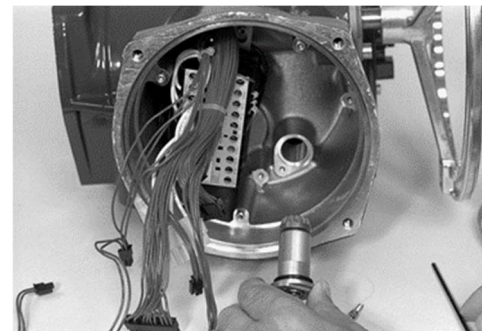

## 4 Installing Components

**NOTE:** Before starting the installation of the MXa package in the actuator, the user should perform a visual inspection of the controls compartment. The controls compartment should be free of any debris and any fluid that has seeped into the compartment. Any potential for fluid leakage into the controls compartment should be addressed prior to the installation of the MXa control package.

**CAUTION:** Ensure the voltage jumper on the power board is located in the proper position. Refer to the nameplate for the actuator voltage. Follow the template provided on the Mylar protection barrier for the proper voltage jumper location.

**CAUTION:** Potential to cause electrostatic discharge damage to electronic components is possible. Ensure that you are electrostatically safe by briefly touching a grounded metal object. Use of a grounded wrist strap when handling electronic components **is recommended.**

### 4.1 MXb Encoder Drive Cartridge Installation

#### STEP 1

Verify the new encoder cartridge has the O-ring installed

Fit the encoder drive cartridge into the actuator housing.



#### STEP 2

Using a 3 mm hex key, fit the M4 screw into the actuator housing to secure the encoder cartridge.



## 4.2 Installation of MXb Encoder

### STEP 1

Install the encoder by aligning the shaft on the encoder drive cartridge with the socket on the encoder.

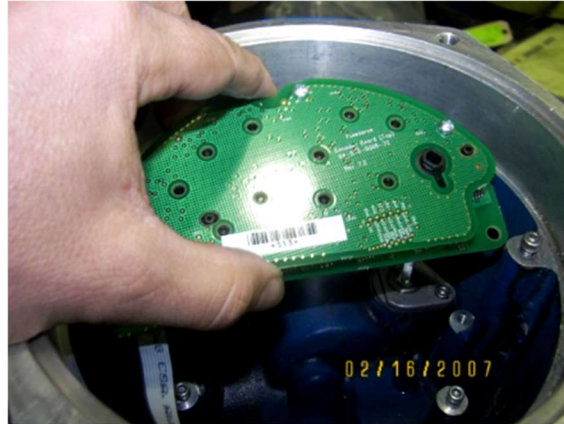

### STEP 2

Secure the encoder to the actuator housing using the three M4 socket head screws supplied.

The two screws identified by the arrows are not used on the MXa assembly and should be removed.

**NOTE:** The screws for the MXa encoder are longer than the screws securing the MX encoder to the actuator housing.

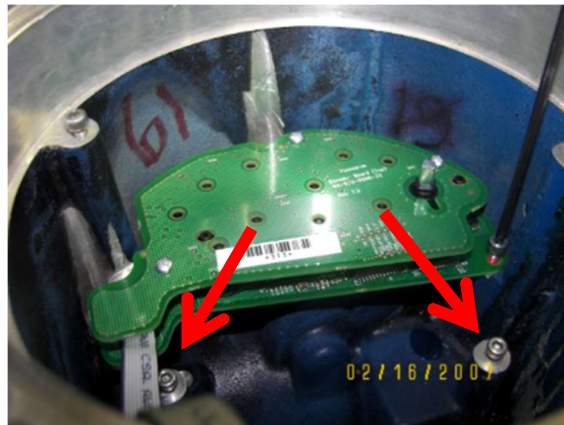

## 4.3 Installation of MXb Motor leads and Terminal Block

**CAUTION:** Be careful when maneuvering wire so not to nick or cut cables.

### STEP 1

Insert the motor leads from the power supply assembly through the housing and into the motor compartment.

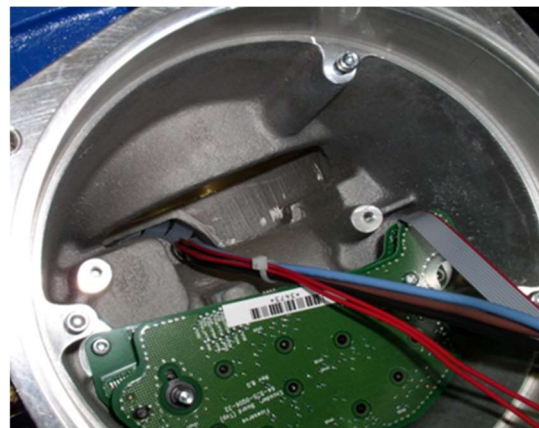

## STEP 2

**NOTE:** Visually inspect flame paths to ensure no damage during removal.

Position the motor near the housing and connect the motor lead connector to the motor connector.



## STEP 3

Position motor leads into the housing cavity around the worm shaft cap.

Bend the grounding connector clip up to prevent the wires from chafing on the rotating shaft.

Push the rotor shaft onto the protruding worm shaft, aligning the rotor shaft slots with the worm shaft pin.

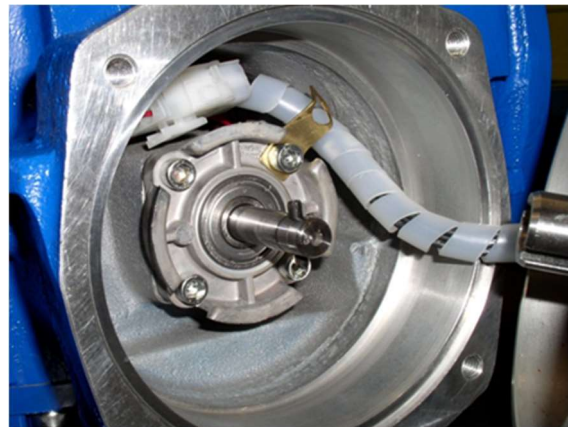

**CAUTION:** Ensure the grounding connector clip is pushed back to a minimum of parallel with relation to the worm shaft cap to prevent arcing to the stator.

## STEP 4

Install the motor into the housing using a steady smooth motion while keeping the motor assembly spigot straight.

Using a 6mm hex wrench, secure the motor assembly to the actuator housing using four M8 socket head bolts.

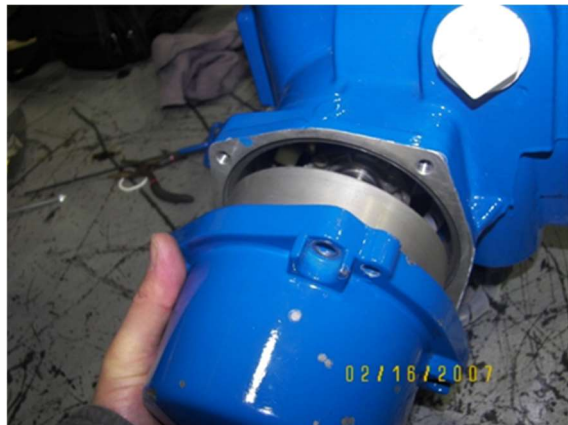

**NOTE:** If the motor sticks before fully engaging, remove and re-attempt installation insuring that the spigot remains straight.

**WARNING:** Do not use a hammer to force the motor into position. This could result in damage to the motor.

**STEP 5**

Position the terminal block/internal harness assembly near the actuator housing.

Insert the wires of the terminal block assembly through the housing and into the electrical compartment.

Ensure the terminal block has the O-ring installed into the O-ring groove and verify all wires are clear.

Apply a light coating of lubricant, from lubricant supplied in kit, to the O-ring before installing the terminal block.

Position the terminal block into the housing and firmly press on the top to seat the terminal block into the O-ring groove.

Insert the retaining ring into one side of the retaining ring groove.

Seat the retaining ring into the groove by working a flat blade screwdriver around the edge until it seats into the groove.



**STEP 6**

Remove any wire tie-wraps bundling the thermistor wire to the bundled 3-phase and motor wires.

Bundle and secure the 3-phase motor wires (thicker, blue, brown, and black wires) with wire ties and trim the excess wire ties.

Bundle and secure the thermistor wires (red wires) with wire ties and trim the excess wire ties.

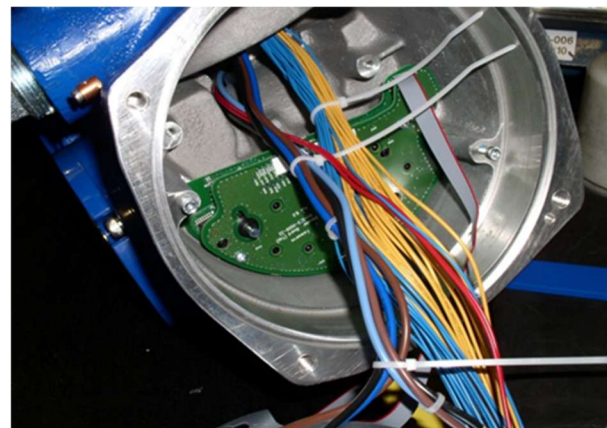

## 3.4 Installation of Power Board

This section describes the installation of the power board modules depending on the actuator the user is starting with.

- 3.4.1– 12A Power Board
- 3.4.2– 19A Power Board
- 3.4.3– SSMR Power Board

### 3.4.1 Installing 12A Power Board

#### STEP 1

Connect the power leads from the terminal block to the power supply assembly.

Connect the motor leads to the power supply assembly.



#### STEP 2

Position the power supply assembly so that the keyhole slots on the mounting plate allow the M4 screw heads to pass through.

Rotate the power supply assembly clockwise until the screw heads seat in the key slots.

Using a 3mm hex key tighten the three M4 screws.



**CAUTION:** Ensure that the jumper on the power supply assembly is set in the correct voltage position.

### 3.4.2 Installing 19A Power Board

**STEP 1**

Install the three (3) standoffs into the control board housing mounting holes. Loosely install M4 screws into standoff.

Remove the circular green PCB from the contactor assembly saving all parts removed.

**STEP 2**

Connect the two 2-pin white connectors to the motor leads.

Install the 19 amp controls assembly by slightly rotating the controls assembly in the clockwise (CW) direction, then tighten the three M4 mounting plate screws.

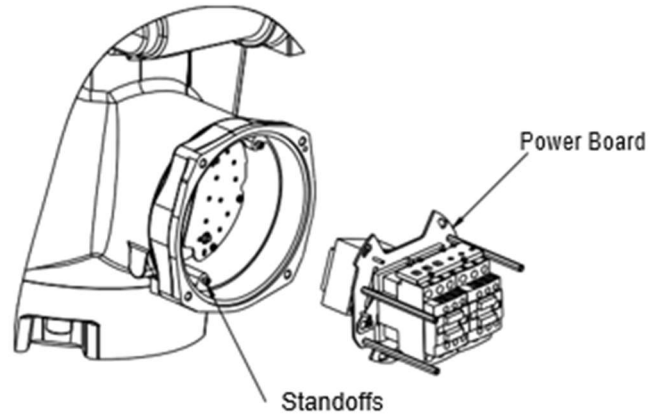

**STEP 3**

Install the 3 terminal block wires L1, L2, L3 to the contactor and screw down as shown below

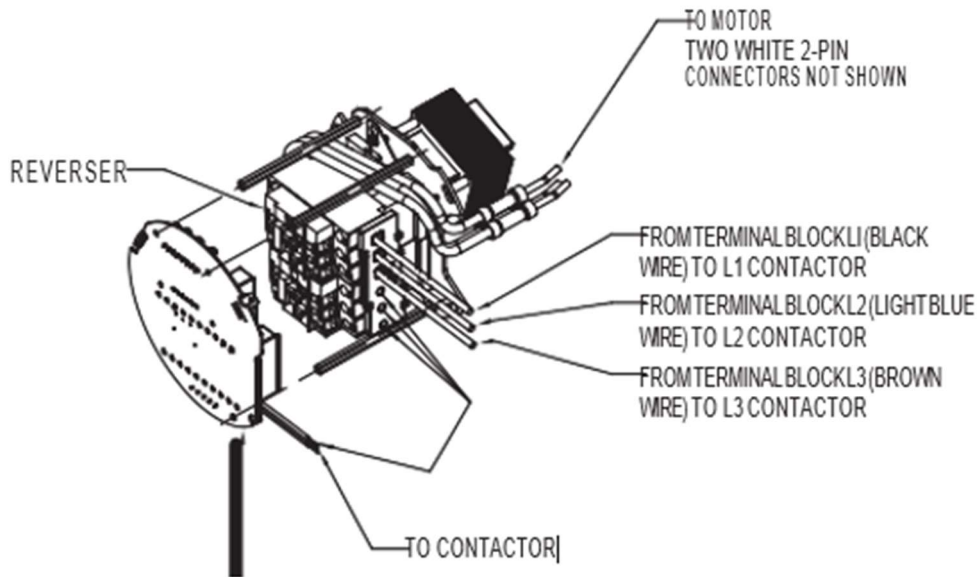

**STEP 4**

Reconnect cables to PCB and re-attach shield and PCB to reverser standoffs using the 3 screws that were removed before.

**CAUTION:** Do not forget the shield

**CAUTION:** Ensure that the jumper on the power supply assembly is set in the correct voltage position.

### 3.4.3 Installing SSMR Power Board

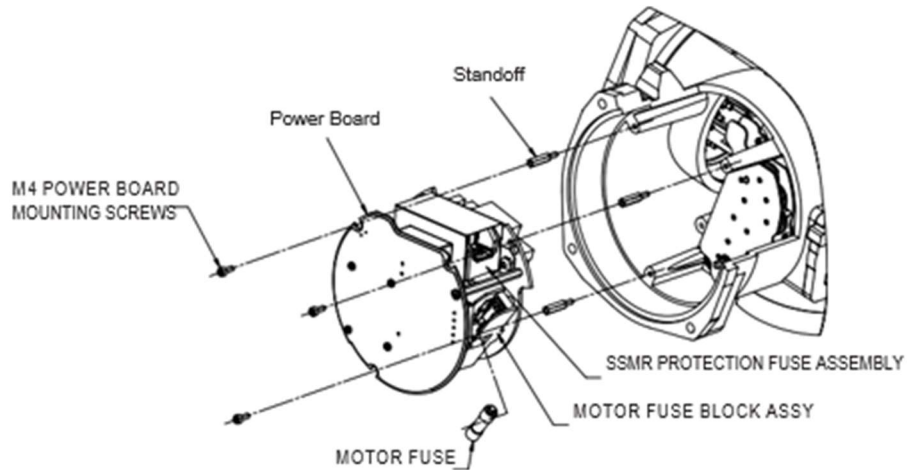

**STEP 1**

Install the three (3) standoffs into the control board housing mounting holes. Loosely install M4 screws into standoff.

**STEP 2**

Ensure the SSMR fuses are correct per table. Confirm the motor FLA current from the nameplate to find the fuse part number to confirm.

| Nameplate    | Limitorque P/N | Ferraz-Shawut |
|--------------|----------------|---------------|
| .6 to .89    | 102478         | ATDR 1-6/10   |
| .9 to 1.34   | 102480         | ATDR 2-1/2    |
| 1.35 to 2.25 | 102482         | ATDR 4        |
| 2.26 to 3.2  | 102484         | ATDR 6        |
| 3.21 to 4    | 102487         | ATDR 9        |
| 4.1 to 6     | 102488         | ATDR 12       |

**STEP 3**

Plug the 3-pin Molex power harness from the terminal block and the motor harness into the SSMR Power board.

**STEP 4**

Position the power supply assembly so that the keyhole slots on the mounting plate allow the M4 screw heads to pass through.

Rotate the power supply assembly clockwise until the screw heads seat in the key slots.

Using a 3mm hex key tighten the three M4 screws.

**CAUTION:** Ensure that the jumper on the power supply assembly is set in the correct voltage position.



### 3.5 Installation of MXb Controls

**NOTE:** The conversion from MX or MXa to MXb consists of replacing the user interface. This includes the control cover, control cover screws and the PC board stack that includes the host controller PC board and user interface PC board. Utilize new ribbon cable that came attached to MXb Host Controller Assembly (Main board)

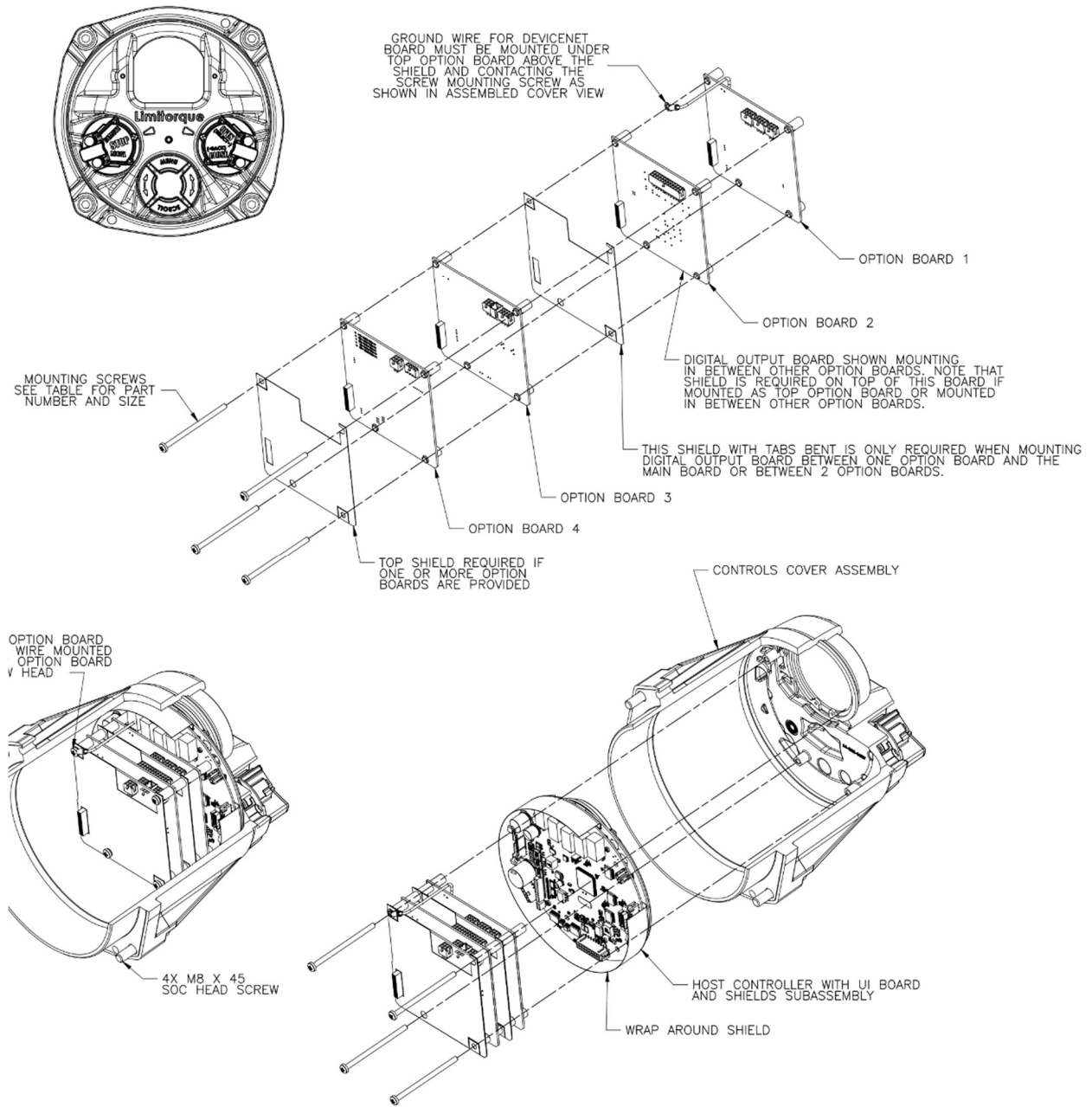

**STEP 1**

Before installation of electronics, place O-Ring (CMA-M167X4) on controls cover flange.

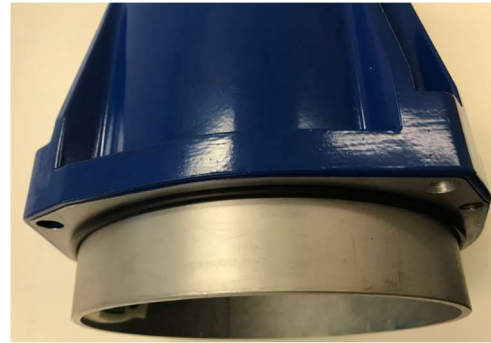

**STEP 2**

Place the option PC boards in a stack plugged together at the board to board connector. Connect the option boards to their respective cables. Plug the option board stack on to the MXb host controller PC board. Connect the 6 or 7 connectors to the MXb host controller PC board.

**NOTE:** If MXa unit has R1-R4 relay card installed (OA or OC configurations) remove the R1-R4 board from the stack. The R1-R4 is now part of the MXb user interface. R1-R4 boards are identified by J1 on 64-825-0043 relay option board.

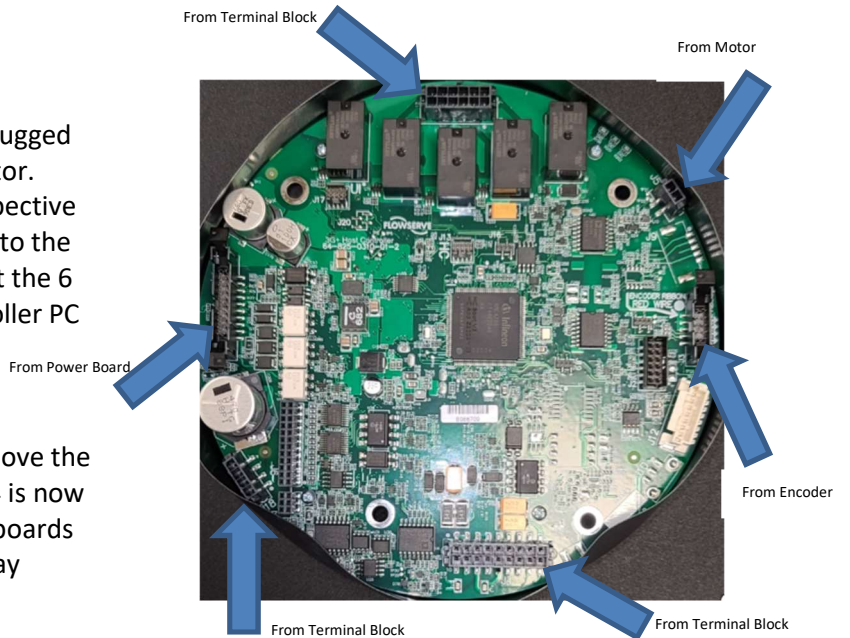

**STEP 3**

Place and secure the MXb PC board stack inside the MXb control cover using the screws from the below table.

| BOARD DESCRIPTION          | SCREW PART NUMBER | DESCRIPTION | QTY. |
|----------------------------|-------------------|-------------|------|
| MAIN WITH NO OPTION BOARDS | 64-818-0001-35    | M4X8        | 4    |
| MAIN WITH 1 OPTION BOARD   | 64-818-0001-32    | M4X25       | 4    |
| MAIN WITH 2 OPTION BOARDS  | 64-818-0001-36    | M4X40       | 4    |
| MAIN WITH 3 OPTION BOARDS  | 64-818-0004-3     | M4X55       | 4    |
| MAIN WITH 4 OPTION BOARDS  | 64-818-0005-3     | M4X70       | 4    |



**STEP 4**

CAUTION: Potential to pinch cables. When mounting MXb control cover take special care not to pinch cables.

**STEP 5**

Dress the cables being careful to position wires so that they pass perpendicularly over the housing flange.

**STEP 6**

The face of the MXb may be installed in any one of four 90° incremental positions. When changing MXb position, avoid over-twisting the cables.

Rotate the MXb control cover until the display orientation of the front face is correct for normal viewing, and then slide the ACP assembly into the actuator housing.

**STEP 7**

Secure the MXb control cover to the housing using quantity 4 diameter M8 socket head cap screw 45mm long per the following:

| Nameplate Marking                    | Fastener P/N                          |
|--------------------------------------|---------------------------------------|
| Weatherproof and FM Group C&D        | P/N HCB-M8X45 Stainless Steel         |
| FM Group B, ATEX, IECEx & all others | P/N HCM-M8X45 Class 12.9 plated steel |



**Caution:** Do not use fasteners from MXa for securing the MXb control cover. The MXb flange on the control cover is thicker and requires a longer screw that is new to the MX product family. This new fastener is 45mm long and engages the housing 16mm after passing thru the 29mm flange on the MXb control cover.

### 3.6 Initialize and Commission of MXb

**STEP 1**

Install the actuator per MXb installation and operating manual VAIOM000071. See section 3.3 in manual VAIOM000071 for connections. Apply nameplate power to the actuator. Prior to commissioning, initialize the actuator per below figure. The following information will be displayed on the user interface.

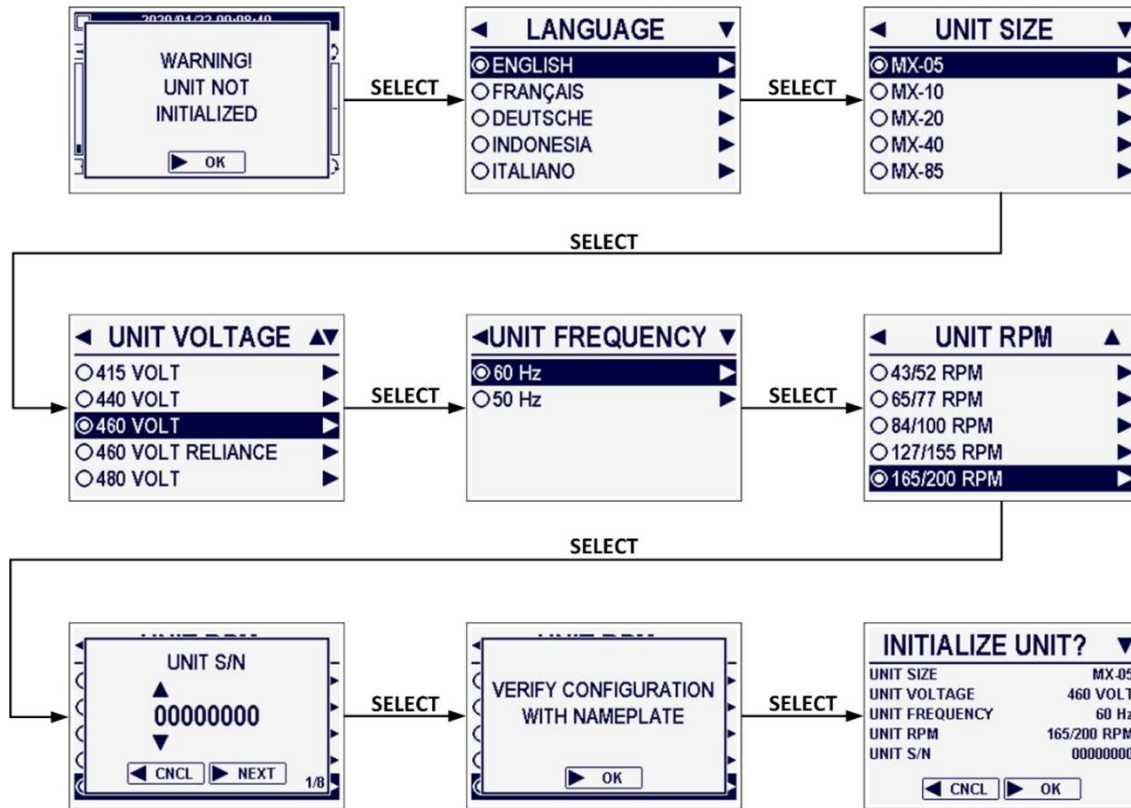

Use menu knob to adjust each digit, then use the right control knob to SELECT it and move to the next digit



**STEP 2**

The MX actuator nameplate needs to be updated. The Conversion kit name plate, from the kit, shall be installed as shown below to reflect the conversion to MXb (Series B). Secure the series B nameplate using the two lower screws of the existing nameplate. Instructions are on the Series B nameplate to place the top portion under the original nameplate.

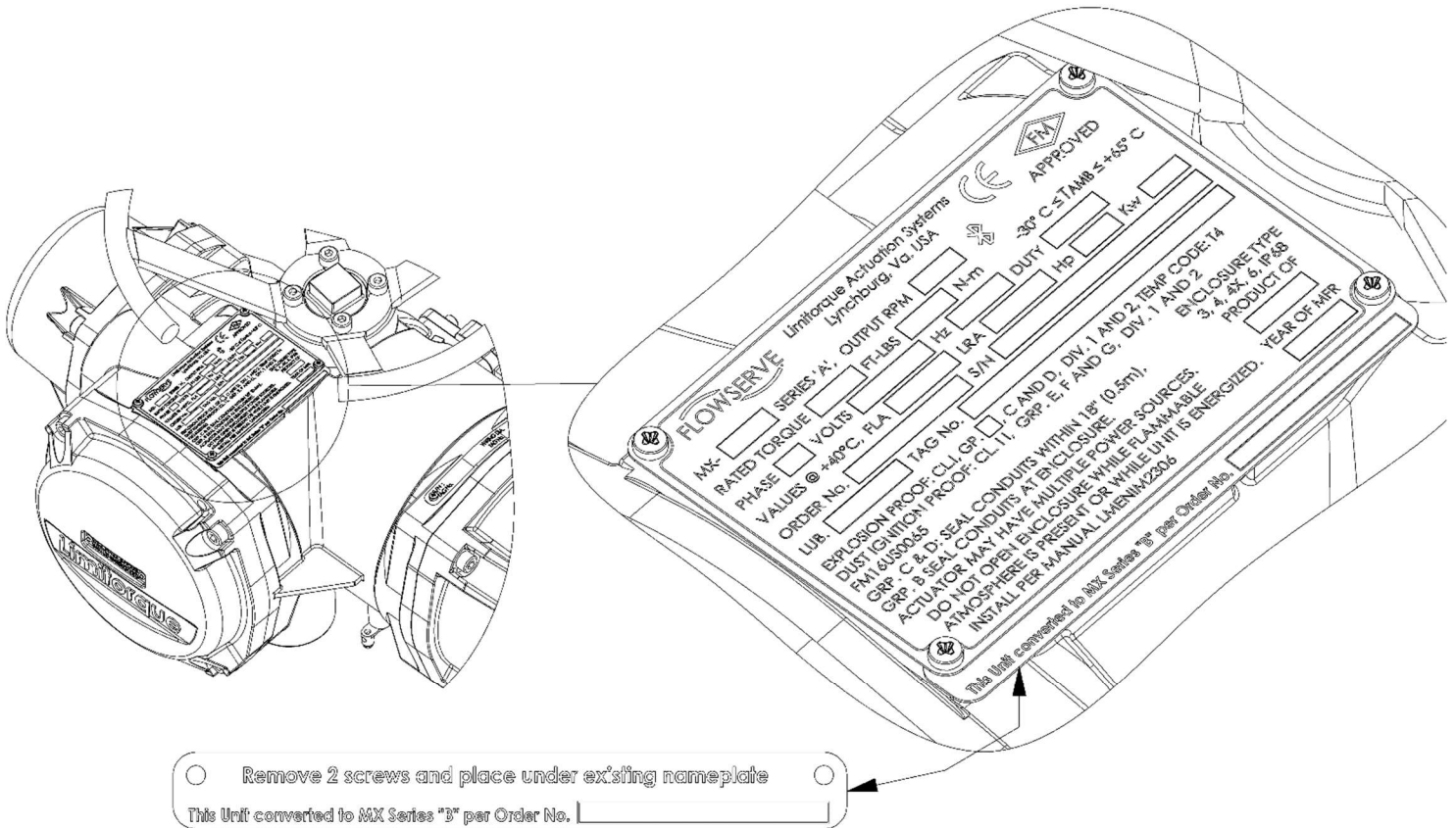

**MXb CONVERSION NAMEPLATE**  
PLACE UNDER EXISTING UNIT NAMEPLATE AS SHOWN

**STEP 3**

The conversion from MXa to MXb is now complete. The actuator can now be commissioned per manual VAIOM000071, section 3.5.

**United States****Flowserve Limitorque**

5114 Woodall Road  
P.O. Box 11318  
Lynchburg, VA 24506-1318  
Phone: 434-528-4400  
Fax: 434-845-9736

**Italy****Flowserve Limitorque**

via Rio Vallone 17  
20883 Mezzago (MB), Italy  
Phone: +39 039 62060 213  
Fax: +39 039 62060 1

**Singapore****Limitorque Asia**

Pte., Ltd. 12, Tuas Avenue 20  
Singapore 638824  
Phone: 65-6868-4628  
Fax: 65-6862-4940

**China****Limitorque Beijing**

Pte., Ltd. RM A1/A2  
22/F, East Area  
Hanwei Plaza No. 7  
Guanghua Road  
Chaoyang District  
Beijing 100004  
Peoples Republic of China  
Phone: 86-10-5921-0606  
Fax: 86-10-6561-2702

**India****Flowserve Limitorque**

Office A, 7<sup>th</sup> Floor  
Plot Nos. 32A & B Ambit IT Park  
Ambit IT Park Road Ambattur  
Industrial Estate  
Chennai – 600058  
Phone: 91-44-2432-8755  
& 91-44-2432-4801  
Fax: 91-44-2432-8754

---

Flowserve Corporation  
5215 North O'Connor Blvd. Suite 2300  
Irving, Texas 75039-5421 USA  
Telephone: +1 937 890 5839

Flowserve Corporation has established industry leadership in the design and manufacture of its products. When properly selected, this Flowserve product is designed to perform its intended function safely during its useful life. However, the purchaser or user of Flowserve products should be aware that Flowserve products might be used in numerous applications under a wide variety of industrial service conditions. Although Flowserve can provide general guidelines, it cannot provide specific data and warnings for all possible applications. The purchaser/user must therefore assume the ultimate responsibility for the proper sizing and selection, installation, operation, and maintenance of Flowserve products. The purchaser/user should read and understand the Installation Instructions included with the product, and train its employees and contractors in the safe use of Flowserve products in connection with the specific application.

While the information and specifications contained in this literature are believed to be accurate, they are supplied for informative purposes only and should not be considered certified or as a guarantee of satisfactory results by reliance thereon. Nothing contained herein is to be construed as a warranty or guarantee, express or implied, regarding any matter with respect to this product. Because Flowserve is continually improving and upgrading its product design, the specifications, dimensions and information contained herein are subject to change without notice. Should any question arise concerning these provisions, the purchaser/user should contact Flowserve Corporation at any one of its worldwide operations or offices.

©2020 Flowserve Corporation. All rights reserved. This document contains registered and unregistered trademarks of Flowserve Corporation. Other company, product, or service names may be trademarks or service marks of their respective companies.

**AIIOM000150-00 (EN) Aug 2020**