

Process Flow Diagrams

ETHYLENE



Experience In Motion

Ethylene Steam Cracker Process

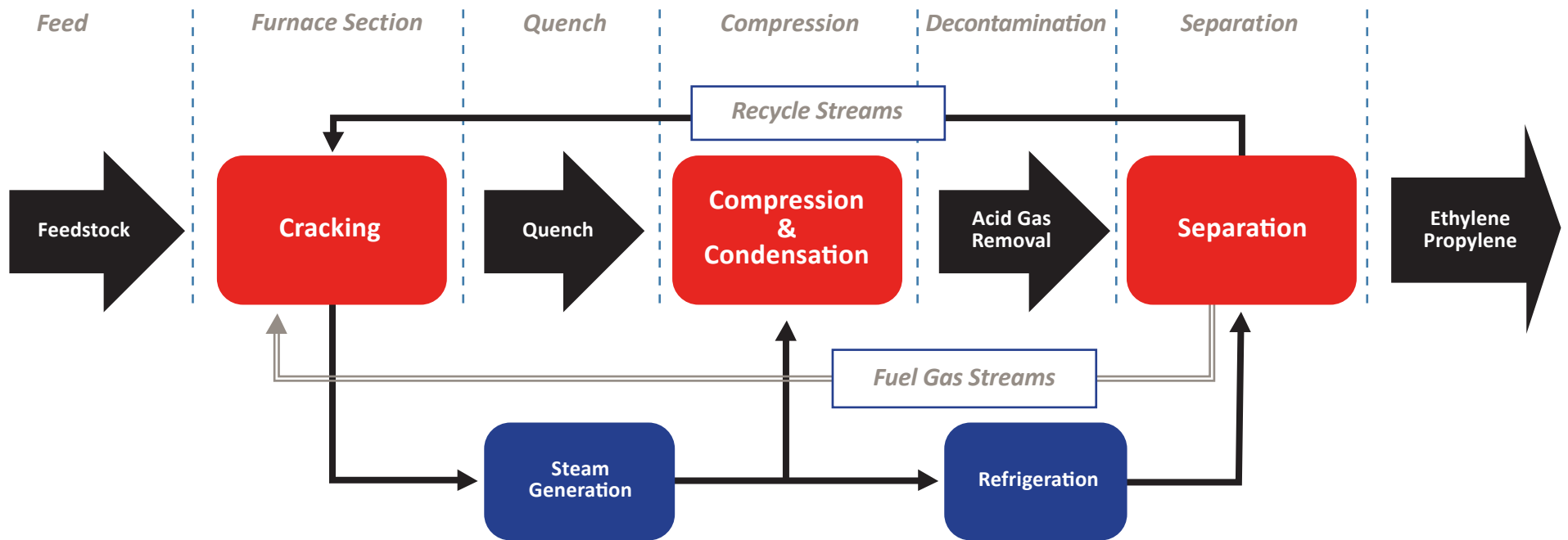

Overall Flow Diagram of Ethylene Processes

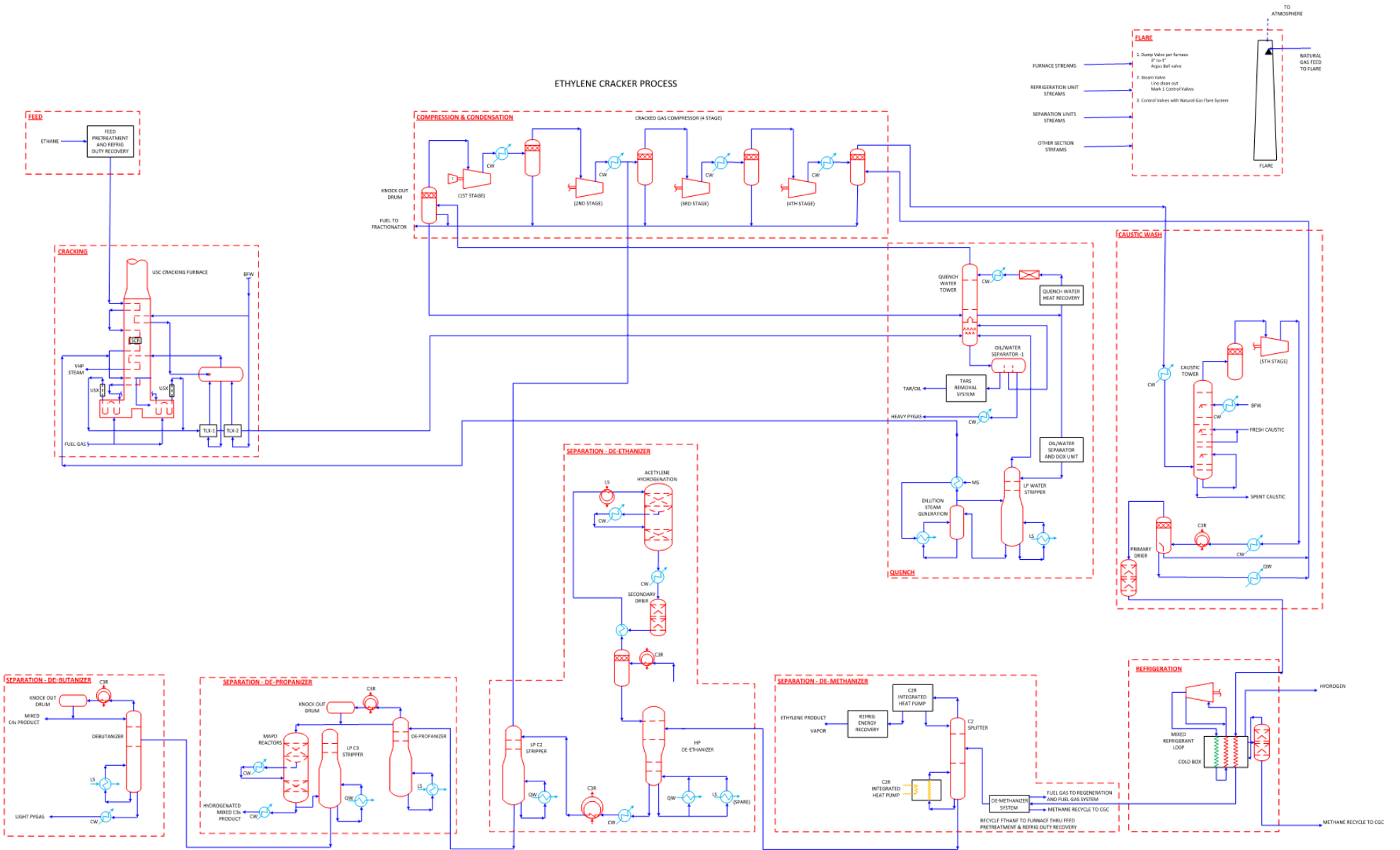

Ethylene Cracker, Feed Section

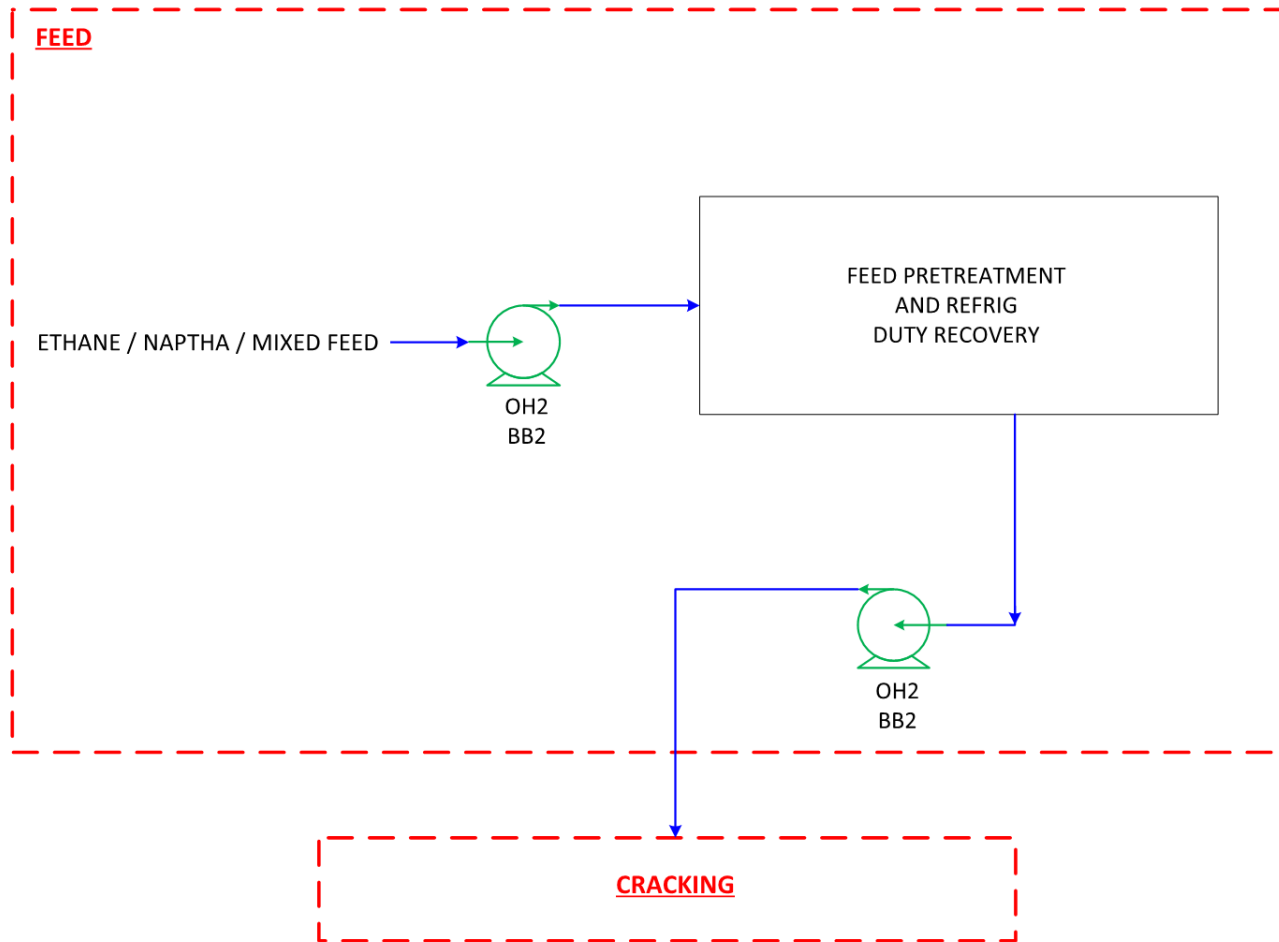

Ethylene Cracker, Cracking Section

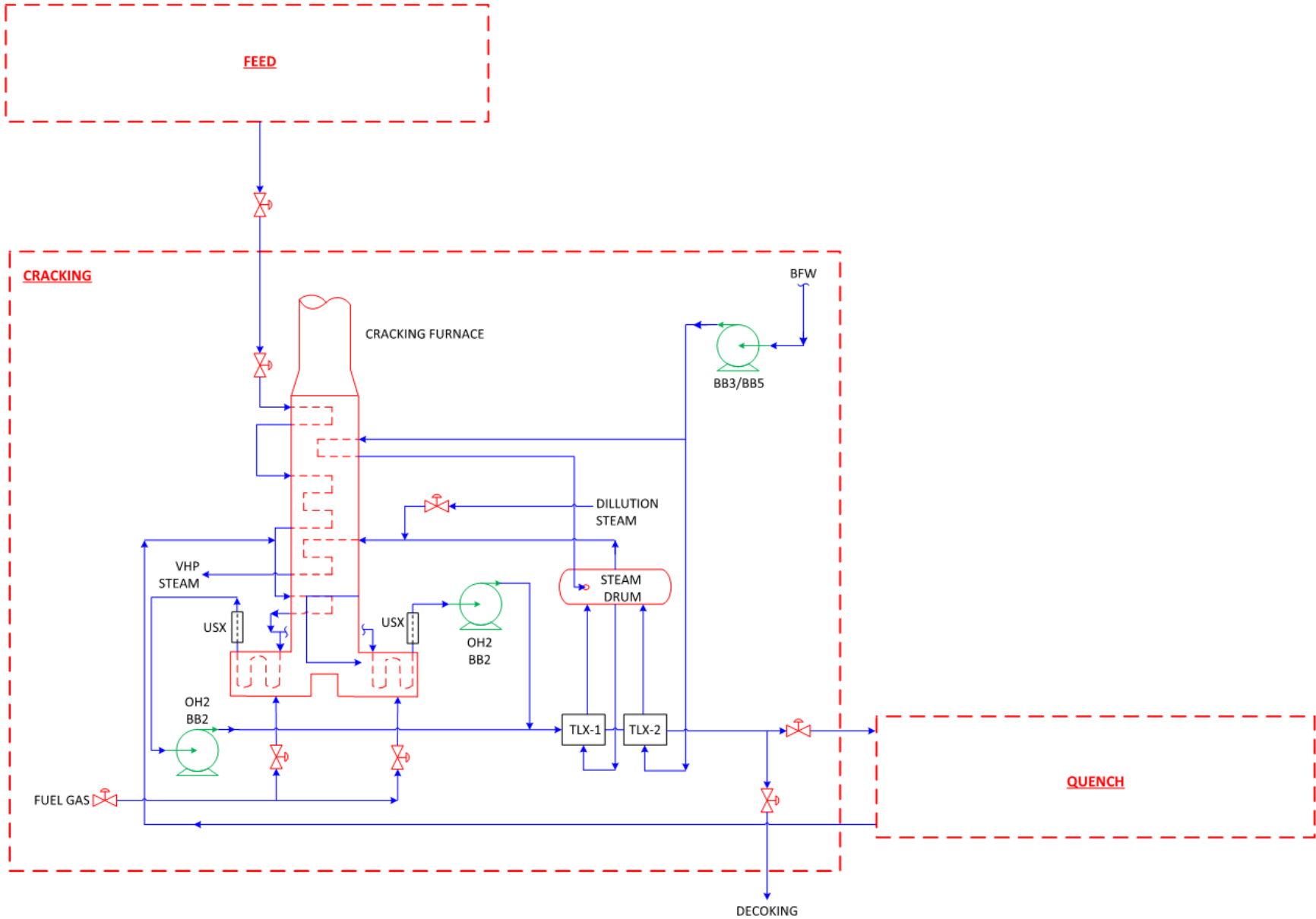

Ethylene Cracker, Quench Section

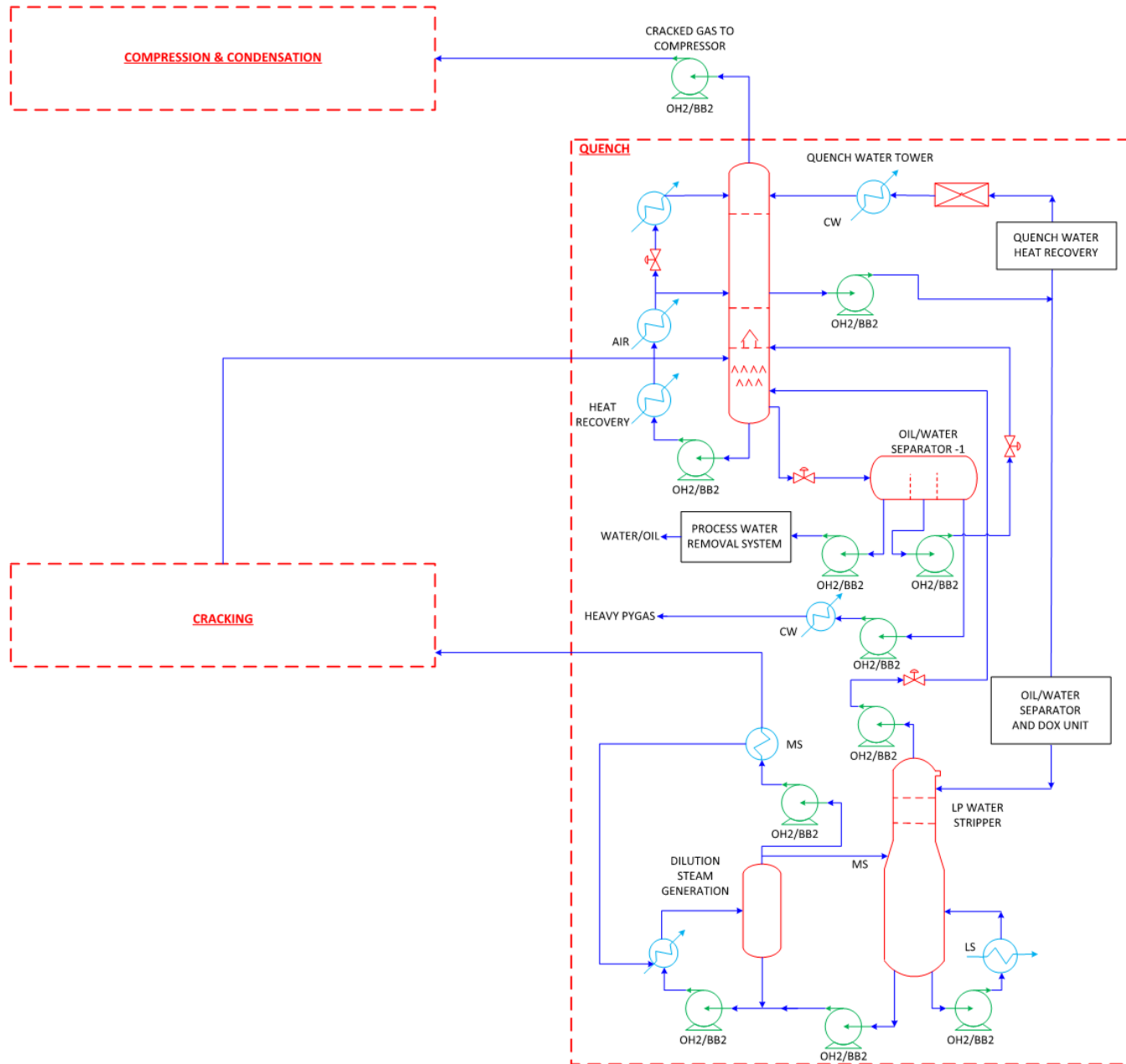

Ethylene Cracker, Compression Section

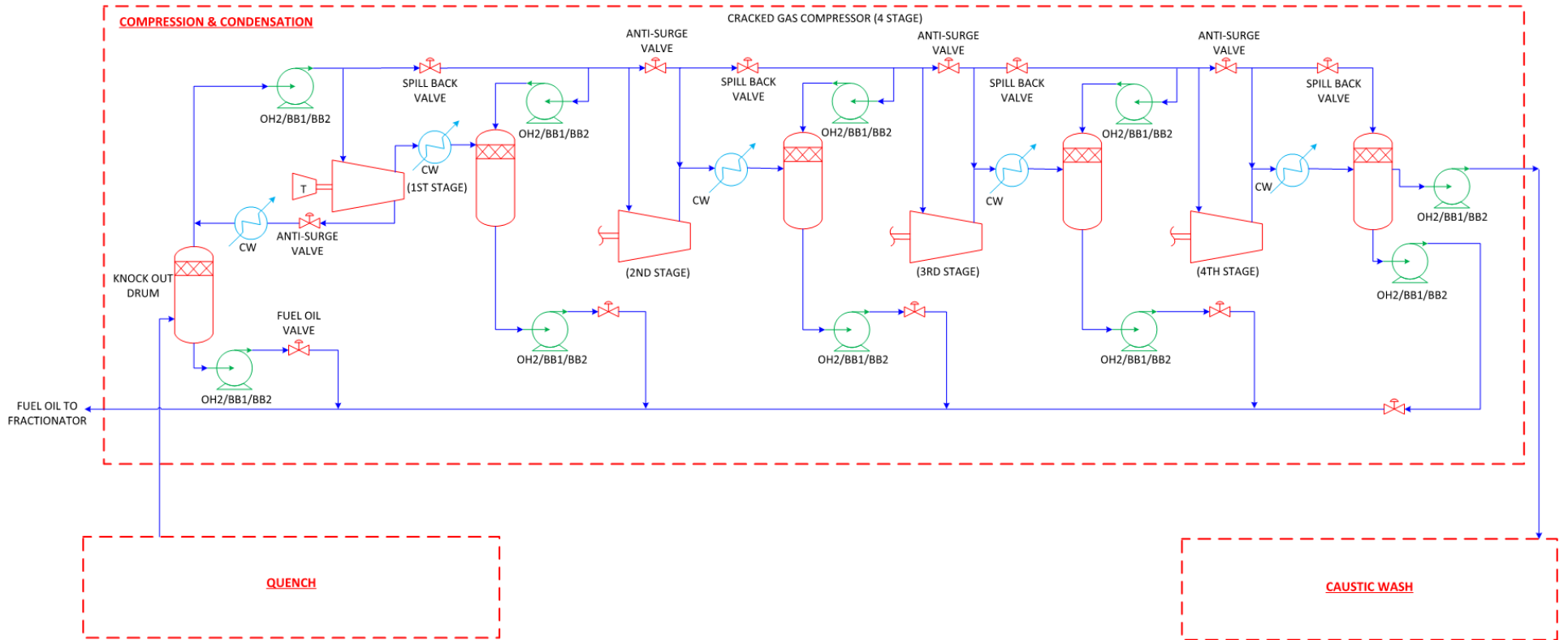

Ethylene Cracker, Caustic Wash Section

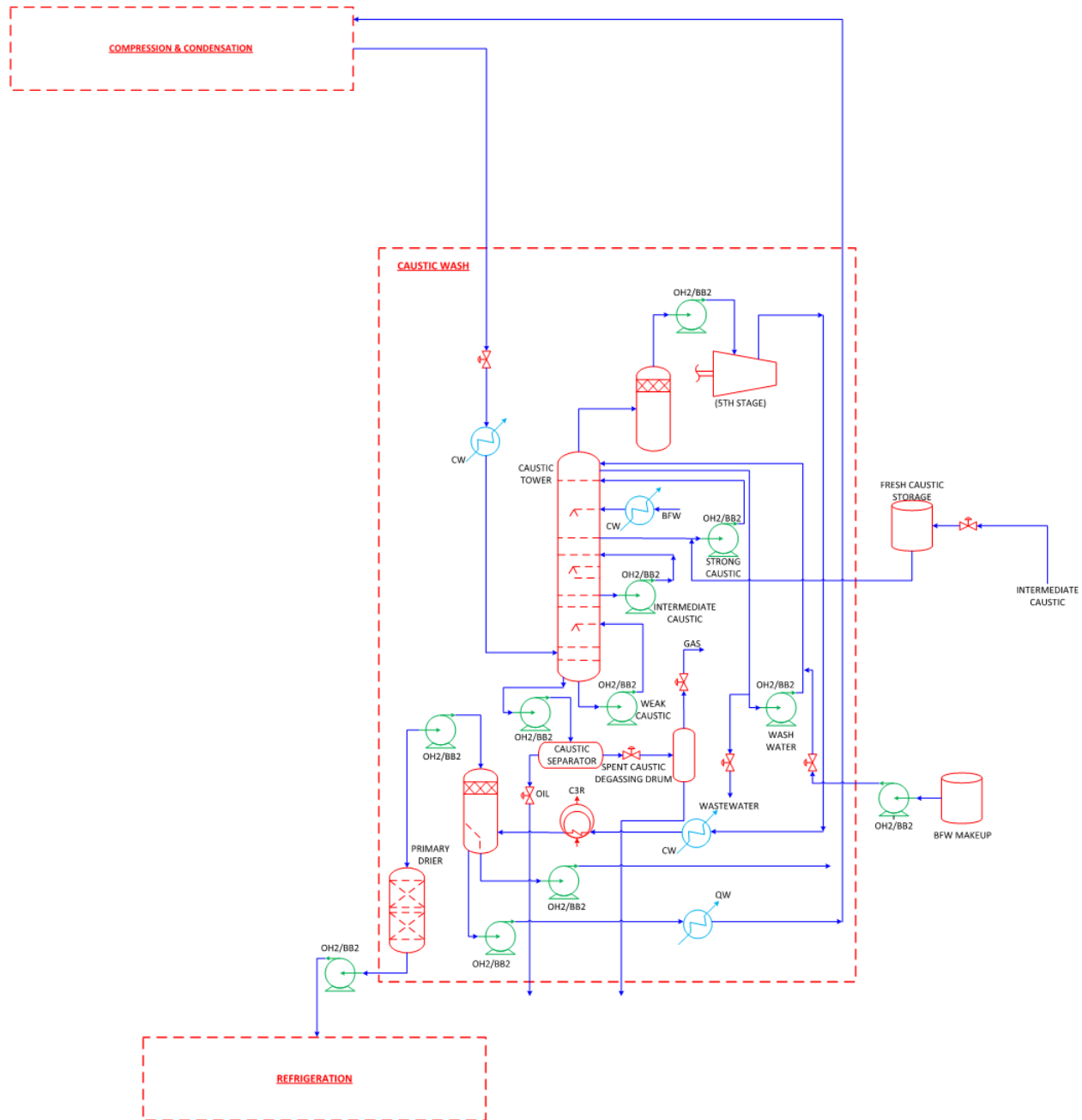

Ethylene Cracker, Refrigeration Section

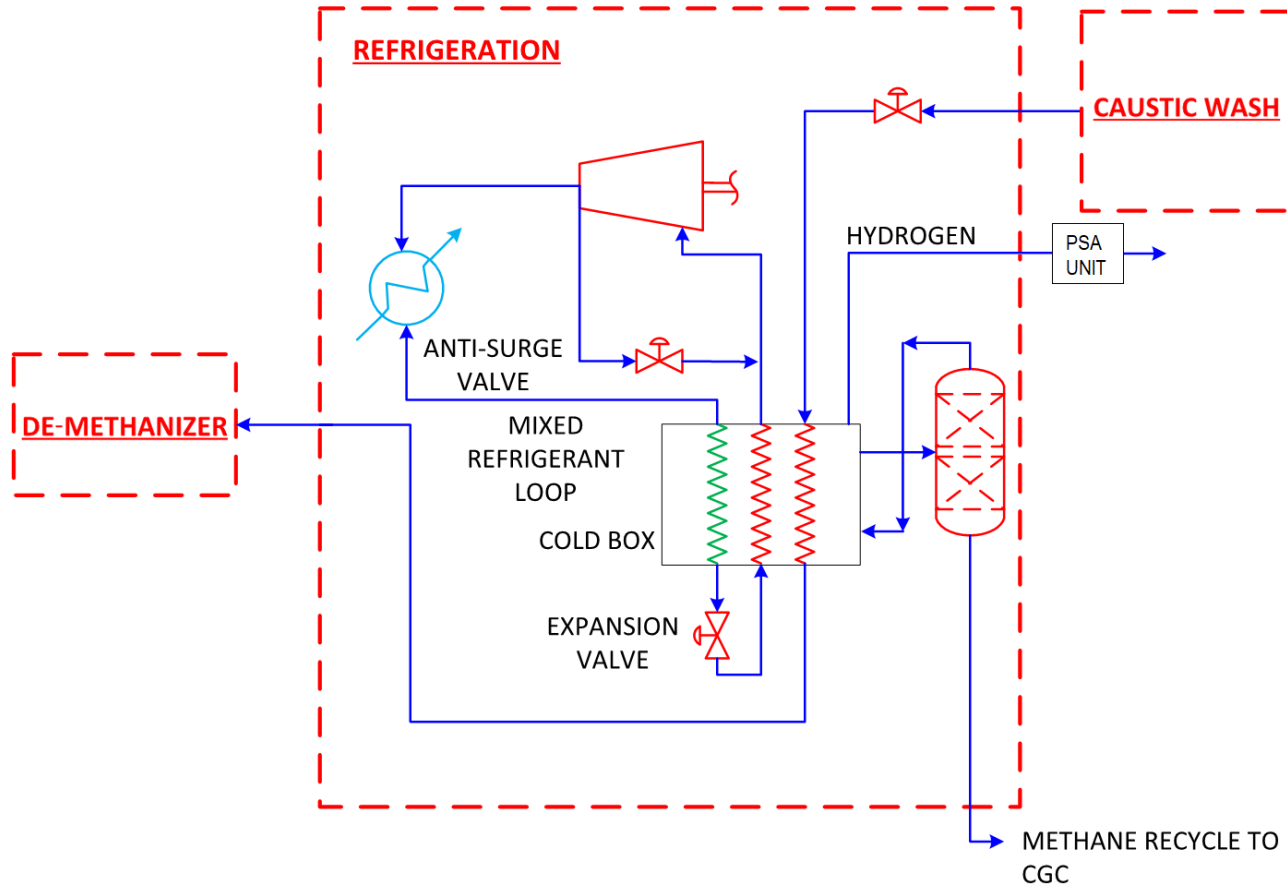

Ethylene Cracker De-Methanizer

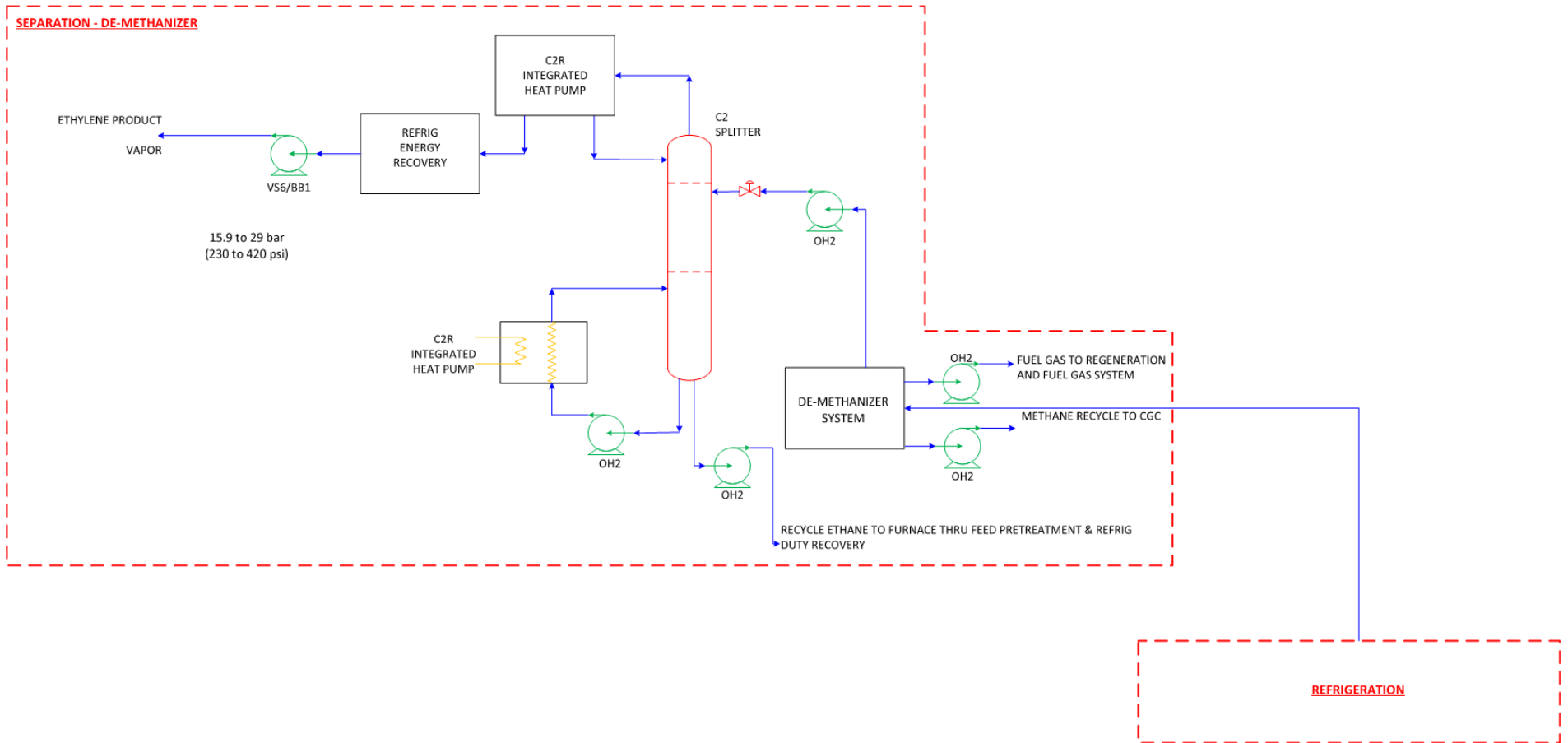

Ethylene Cracker De-Ethanizer

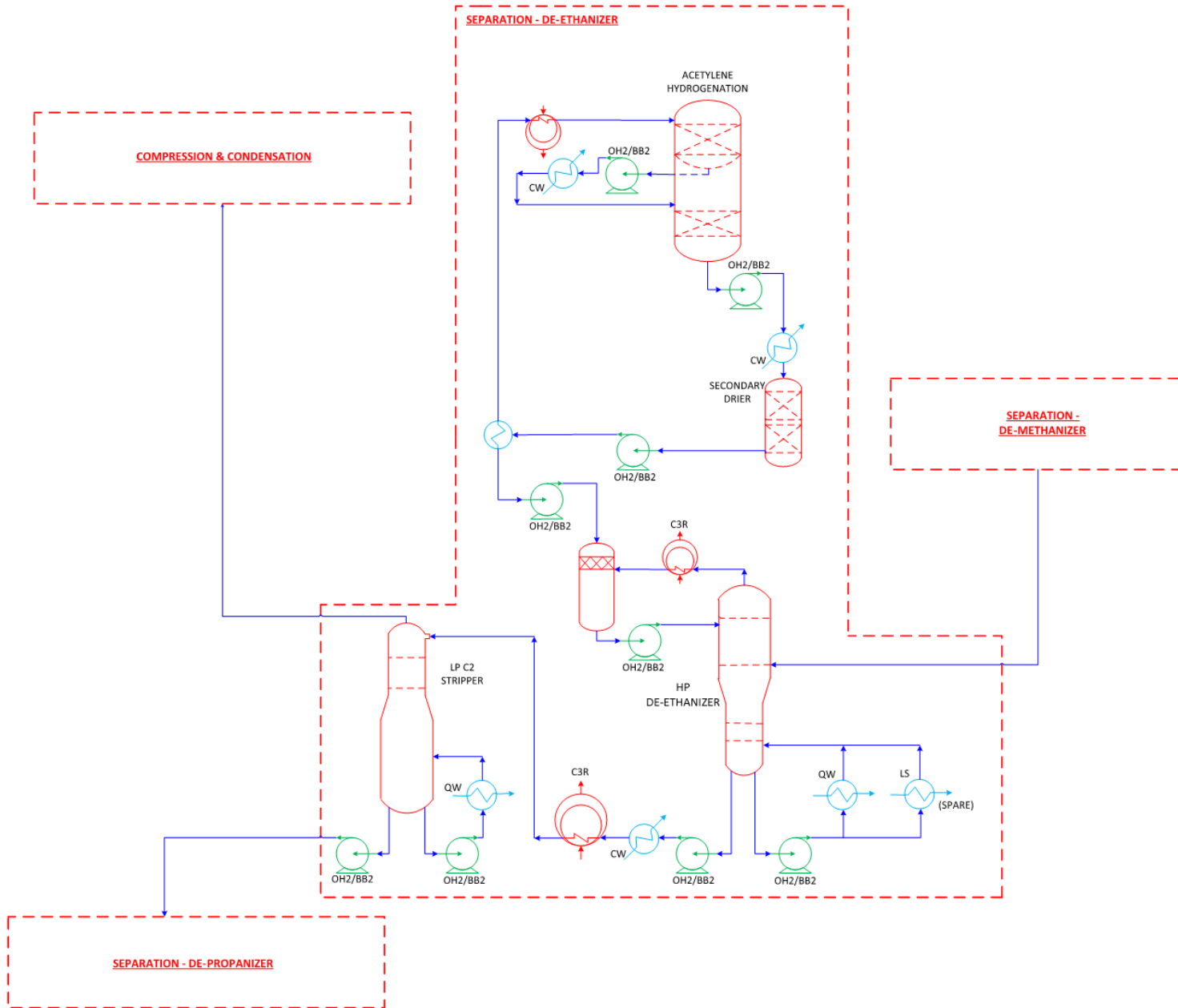

Ethylene Cracker De-Propanizer

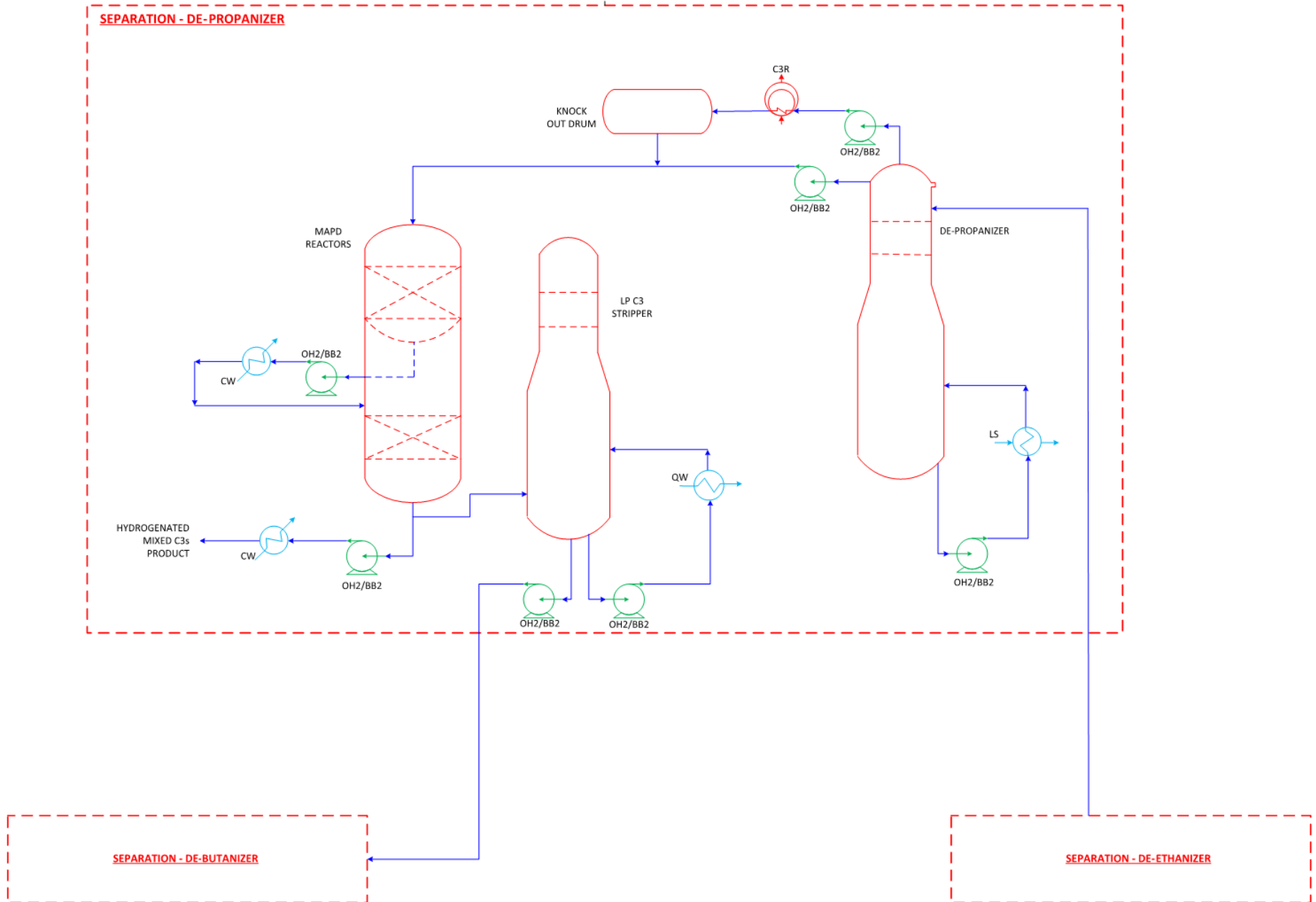

Ethylene Cracker De-Butanizer

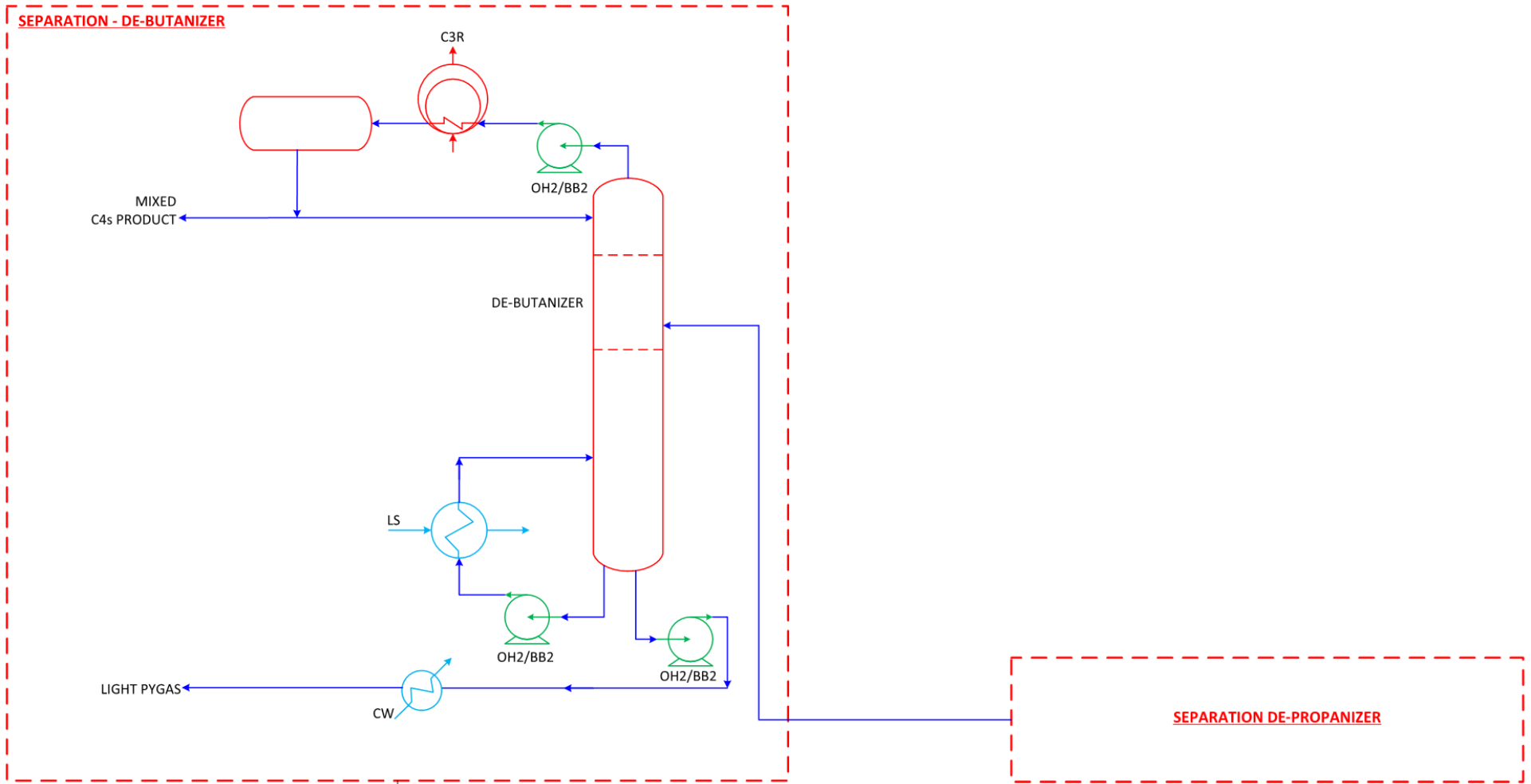



North America

Latin America

Europe

Middle East

Africa

Asia-Pacific

Flowserve Corporation
5215 North O'Connor Boulevard
Suite 2300
Irving, Texas 75039
flowserve.com

Experience In Motion

PRODASG000001 (EN/AQ) ASG-Ethylene Diagrams, February 2020 © 2020 Flowserve Corporation. All rights reserved.
Flowserve and the Flowserve design are registered marks of Flowserve Corporation. All other marks are the property of their respective owners.