

Pressure-tracking system promotes long seal life and reliability

The PA piston accumulator provides optimal lubrication to promote long seal life and reliability for double mechanical seals using Plan 53C piping systems in oil and gas and chemical applications. It provides a constant supply of clean, cool and pressurized barrier fluid to the faces of the dual mechanical seal. The pressure source for the barrier fluid system is the pump seal chamber. This allows the piston accumulator to track the seal chamber pressure and boost the pressure to the mechanical seal.

The PA piston accumulator is optimized to have a working volume that meets API 682, 4th edition and is larger than the standard working volume for a 5-gallon API reservoir.

Pressure tracking makes it work

The PA piston accumulator utilizes the differential surface area of the piston to create consistent higher pressure at the mechanical seal:

- One compartment of the cylinder, labeled Volume A in the adjacent diagram, is piped to the pump seal chamber.
- The second compartment — which has a smaller piston surface area and is labeled Volume B — is piped to the mechanical seal.
- The PA piston accumulator uses the pressure in the seal chamber to pressurize Volume A, then using differential piston surface areas, develops a higher pressure in Volume B.

Since the barrier pressure is generated from the pressure in the pump seal chamber, the system is self-energizing and automatically reacts to fluctuations in seal chamber pressure. This pressure-tracking capability ensures the pressure at the seal is always greater than the pressure in the seal chamber.

Benefits

- Compliant with API 682, 4th edition
- Designed to ASME VIII.1
- Easy to retrofit due to compact design
- Field repairable
- Instrumentation options available
- Standard design for quick delivery
- U-stamp and PED (2014/68/EU) optional

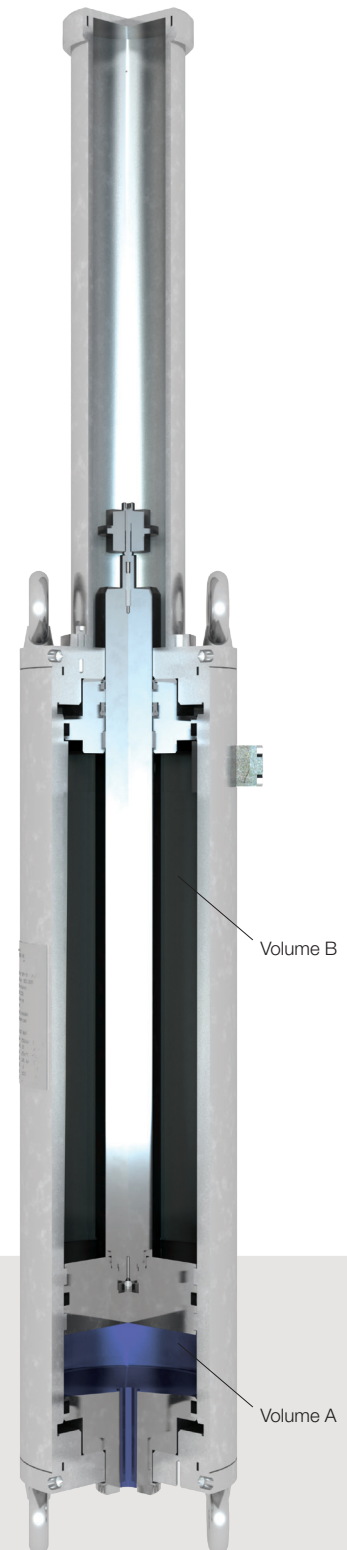

Model numbers

Example:		Working volume	Reference pressure connection	Boost ratio	Seal pressure connection	Flange rating
PA15N115N00	PA	15	N	115	N	00
Model						
1.5 U.S. gallons						
N for NPT, F for flange						
1.15 : 1						
N for NPT, F for flange						
00 for ½ in NPT, 06 for CL 600, 15 for CL 1500						



Plan 53C

