

SIHI® Dry PD Mi Series **Single-stage, dry-running vacuum** **pumps for process applications**

Models Mi450 and Mi650

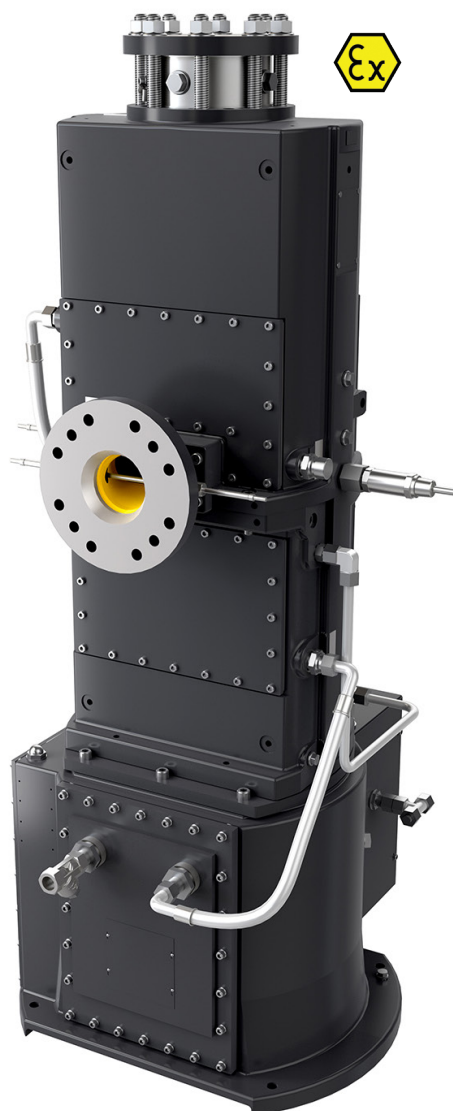

Deep vacuum in a clean, dry-running design

SIHI® Dry PD Mi Series vacuum pumps were specifically developed for use in chemical, pharmaceutical and other process applications requiring deep vacuum. Unlike conventional twin-screw vacuum pumps, SIHI Dry PD Mi Series pumps do not require fluids for sealing or lubricating. Their dry-running design eliminates fluid acquisition and disposal costs while allowing uncontaminated solvent and process vapors to be recovered downstream. Moreover, their advanced design can help reduce the time required to achieve target vacuum levels, improving throughput times and process efficiencies.

Benefits

- **High reliability**, even under harsh process conditions, due to particle and liquid carryover possibility and safe handling of condensable, corrosive or toxic media
- **High availability** due to integrated condition monitoring with pre-failure detection and data logging
- **Minimal downtime** due to self-draining, top-down flow and simple on-site serviceability by own staff
- **Low total cost of ownership** due to elimination of lubrication and mechanical seals, low-maintenance costs and energy-efficient design

Applications

SIHI Dry PD Mi Series dry-running vacuum pumps are engineered to develop deep vacuum under demanding process conditions, including those in classified areas.

Principle industries

- Chemical
- Fine chemical
- Pharmaceutical

Key vacuum applications

- Distillation
- Drying
- Batch reactors

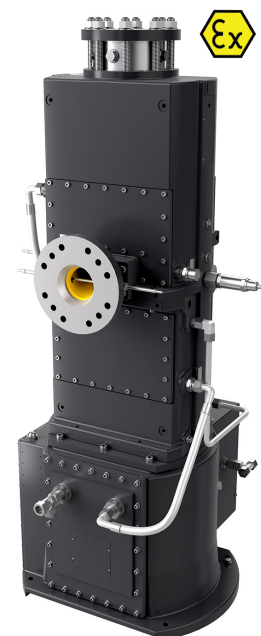

Figure 1:
SIHI Dry Mi450 pump

General technical data

Parameter	Units	Mi450	Mi650
Max. suction capacity	m ³ /h (cfm)	450 (265)	680 (400)
Final pressure	mbar a (mtorr a)	< 0.005 (< 3.75)	< 0.001 (< 7.5)
ATEX certificate	-	Ex II 2 G IIC T3 Gb	Ex II 2 G IIC T2 Gb
Absorbed power at final pressure	kW (hp)	< 4 (< 5.4)	< 6 (< 8.0)
Max. backpressure	mbar g (torr g)	100 (75)	100 (75)
Gas inlet temperature	°C (°F)	0 to 100 (32 to 312)	0 to 100 (32 to 312)
Gas outlet temperature	°C (°F)	≤ 195 (T3) (≤ 383 [T3])	≤ 290 (T2) (≤ 554 [T2])
Sound pressure level ¹	dB (A)	< 70	< 75
System weight	kg (lb)	~400 (~882)	~400 (~882)

¹ DIN ISO 9614 / 21680

Electrical data

Parameter		Mi450	Mi650
Power connection	-	L1, L2, L3, PE (without N)	
Voltage	VAC	400 to 500 ± 10%	
Frequency	Hz	47 to 63	
Protection	-	IP54	
Max. power consumption	kW (hp)	12.5 (16.8)	
Pre-fuse (three-pole)	A	32	

Purge gas

Parameter		Mi450	Mi650
Medium	-	N ₂ (air, CO ₂)	
Gas quality		Min. CLASS 2.4.1 (according to ISO 8573-1:2010)	
Purge gas consumption (in operation)	NI/min (SCFM)	20 (0.71)	
Pressure	barg (psig)	3 to 8 (43 to 116)	

Cooling water

Parameter		Mi450	Mi650
Medium	-	water, conductivity > 50 µS (demineralized water on request)	
Medium temperature	°C (°F)	15 to 40 (59 to 104)	
Max. admissible static medium pressure	barg (psig)	6 (87)	
Min. flow rate	l/min (gpm)	7 (1.85)	

Material design

Wetted parts, process and coolant media sides

Parameter	Item number	Mi450	Mi650
Casing	10	EN-GJS-400-18-LT	
Twin screws	20	EN-GJS-500-14	
Cooling circuit	30	Brass nickel-plated, EPDM, GJL/GJS, 1.0976	
Bearing cartridge	40	1.4021	
Motor casing	50	EN-GJL-250	
Suction strainer (not shown)		Stainless steel/PTFE	

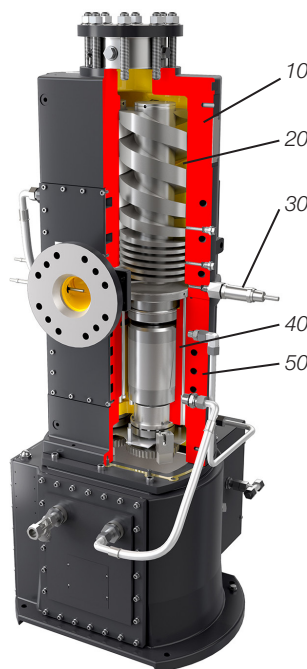

Features and benefits

Built for harsh processes

Tolerates particle and liquid carryover without any suction side filter

- Top-down flow avoids particle deposits inside of the pump
- No wear caused by particle carryover due to contact-free principle
- Optional integrated liquid cleaning by flushing module
- Particle carryover and pump drying by optional integrated gas flushing module

Handling of condensable and corrosive media

- Prevention of condensation inside of the pump by optional integrated gas dilution module
- Optional integrated liquid cleaning by flushing module
- Reduction of condensation by temperature-controlled operation

Safe handling of toxic media

- Hermetical, tight execution
- Pump internal secondary cooling loop, decoupled from customer cooling water

Improved product quality

High pumping performance

- Remarkably high pump speed at low pressure allows higher flow rate of process gases
- Lower final pressure

Zero process contamination

- Truly dry and contact-free principle free of any service liquids
- Absolutely free of gear oil due to electronically synchronized shafts

Engineered for easy system integration

Certified explosion protection

- ATEX-certified, even without flame arrester in Category 2 systems
- No source of ignition due to consequential contact-free operation

Customized vacuum system solutions

- Pre-engineered modules match all individual process needs

No pressure control valve necessary

- Adjustable suction capacity due to variable rotational speed

An integrated solution

- Pre-engineered modules are completely mounted and tested
- Small-footprint design saves useful space

No PLC control

- Self-controlled, pre-engineered modules
- Local control via human machine interface (HMI) panel
- Data access via Ethernet

Easy communication

- Availability of bus standards as well as I/O interface
- Equipped with HMI

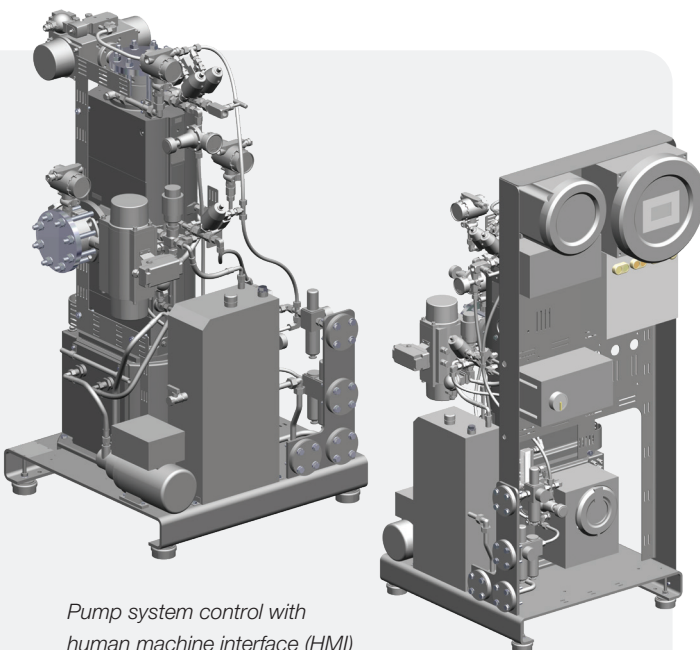

Pump system control with human machine interface (HMI)

Fast installation and startup

Self-controlled vacuum system

- Completely assembled, wired, tested and self-controlled vacuum system allows easiest commissioning

Lower maintenance costs and downtime

No oil checks, exchanges and disposals required

- Free of oil as service liquid
- No gear oil

No wearing

- Consequent contact-free principle
- Long-life bearings
- Contact-free sealings

Continuous condition analysis

- Data logging
- Online monitoring of pump status
- Simple failure codes

Easy to clean and service

Only cleaning on demand

- Condition monitoring by independent data record of both shafts
- Pre-failure detection

Designed for in situ cleaning and on-site service

- Easy dismantling of the pump casing without bearing removal
- No high-tech workshop required
- Can be done on-site by own staff
- Independency on third party service

Lower operating costs

Low power consumption

- High-tech screws' design optimized for highest efficiency
- Frequency control allows to improve energy-efficient operation by operator

Easiest cleaning on-site

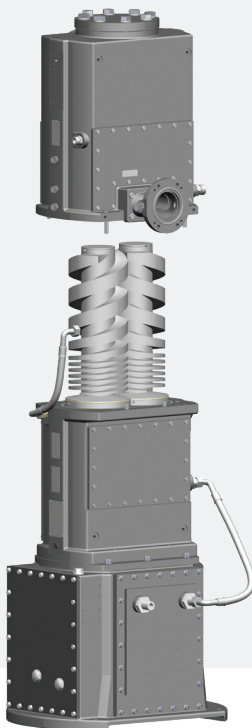

Easiest service on-site

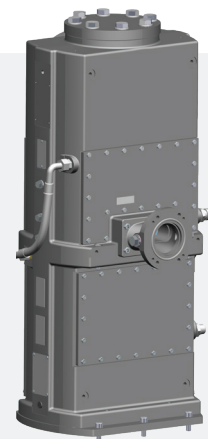
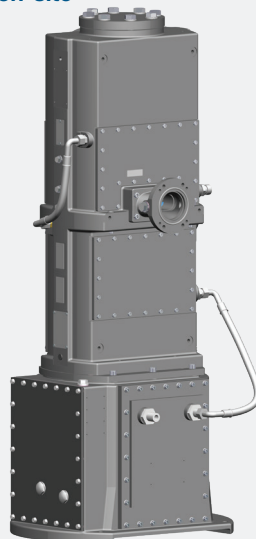

Suction capacity curves

Operating points below the characteristic curve are achievable by speed variation, depending on the system execution.

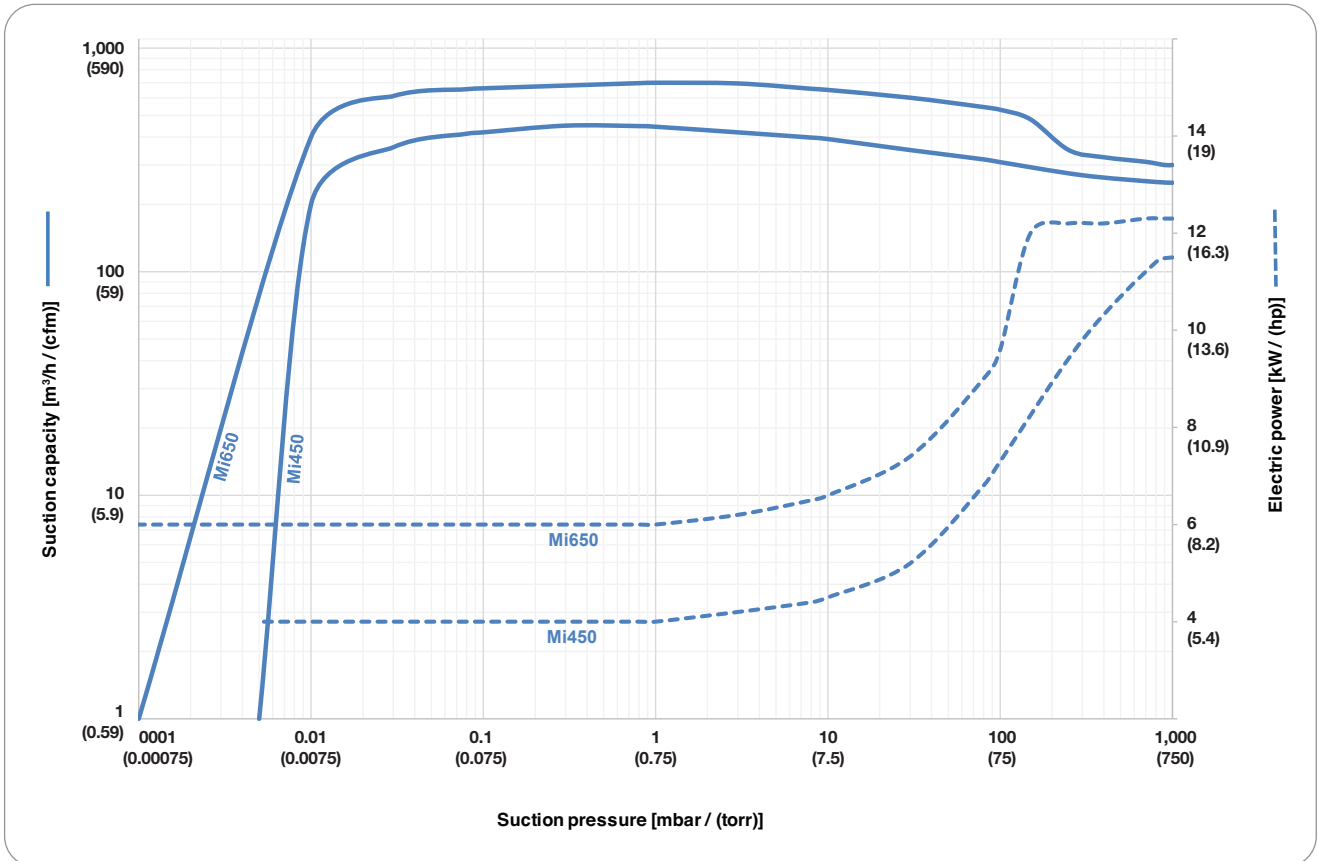

The operating data is valid under following conditions:

- Process media: Dry air 20°C (68°F)
- Cooling media inlet: Water 25°C (77°F)
- Discharge pressure: 1,013 mbar (760 torr) atmospheric pressure
- The suction volume is related to the pressure at the suction nozzle.

Tolerance on operating data is ± 10%.

Pre-engineered systems

SIHI Dry PD Mi Series pumps are available in cost-effective standard packages to ensure peak performance and minimize engineering delays. These fully tested and documented pre-engineered systems enable you to deploy a completely new system quickly or upgrade an existing one.

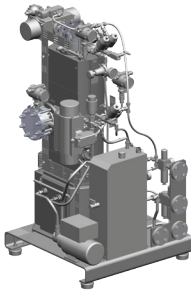
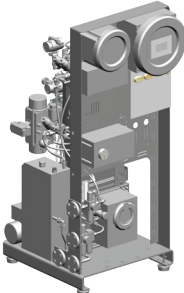
Modules		Pre-engineered systems		
		Standard	Configured	Premium
Vacuum pump	SIHI Dry Mi450 or Mi650	X	X	X
Control	Control FX	X	X	
	Control Profibus DP			X
Supply unit	Supply unit			X
	Protective motor switch			X
Purge gas	Purge gas system	X	X	X
Base frame	Base frame		X	X
	Rack			X
Cooling	Direct cooling without flanges	X		
	Secondary cooling circuit		X	X
Shut-off valve suction	Butterfly valve		X	X
Flushing	Threaded		X	X
Gas dilution	Standard		X	X
Shut-off valve discharge	Butterfly valve		X	X
Sensors	Evaluated Pt100 sensor in cooling jacket	X	X	X
	Evaluated Pt100 sensor on discharge side		X	X
	Evaluated Pt100 sensor on suction side			X
	Evaluated pressure-side pressure transmitter	X	X	X
	Evaluated suction-side pressure transmitter		X	X
				

Pre-engineered systems — Standard

This system configuration provides basic equipment for the operation of the vacuum pump. The scope of supply includes the following components:

Modules		Description
Vacuum pump	SIHI Dry Mi450 or Mi650	<ul style="list-style-type: none"> • Pump • Suction sieve • Integrated motors • Integrated drive control
Control	Control FX	<ul style="list-style-type: none"> • SIHI Control FX fixed-sequence control with sensor evaluation • Integrated communication interface
Purge gas	Purge gas system	<ul style="list-style-type: none"> • Purge gas control unit Ex-p
Cooling	Direct cooling without flanges	<ul style="list-style-type: none"> • The connection to customer's coolant system is directly connected to the pump. A strainer is installed in order to protect the pump.
Sensors	Thermometer pressure transmitter	<ul style="list-style-type: none"> • Evaluated Pt100 sensor in cooling jacket • Evaluated pressure-side pressure transmitter

Available communication interfaces:

I/O interface

- Digital I/O
 - Ex – p Release / Start / Stop / Reset / Operation / Failure / Warning
- Analog I/O
 - Set value speed / Vital status / Current speed value

Bus – Communication

- CANopen Slave ISO11898
- Pump control (see I/O)
- Display of operation mode

Bluetooth® – Communication

- On-site operation via tablet-PC, SIHI BT remote app via Bluetooth communication and vacuum pump integrated SIHI Control FX sequence control

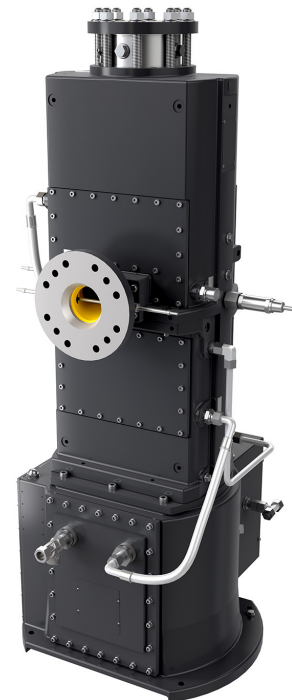

The Bluetooth® word mark and logos are registered trademarks owned by the Bluetooth SIG, Inc. and any use of such marks by Flowserve is under license. Other trademarks and trade names are those of their respective owners.

Dimensions (mm)

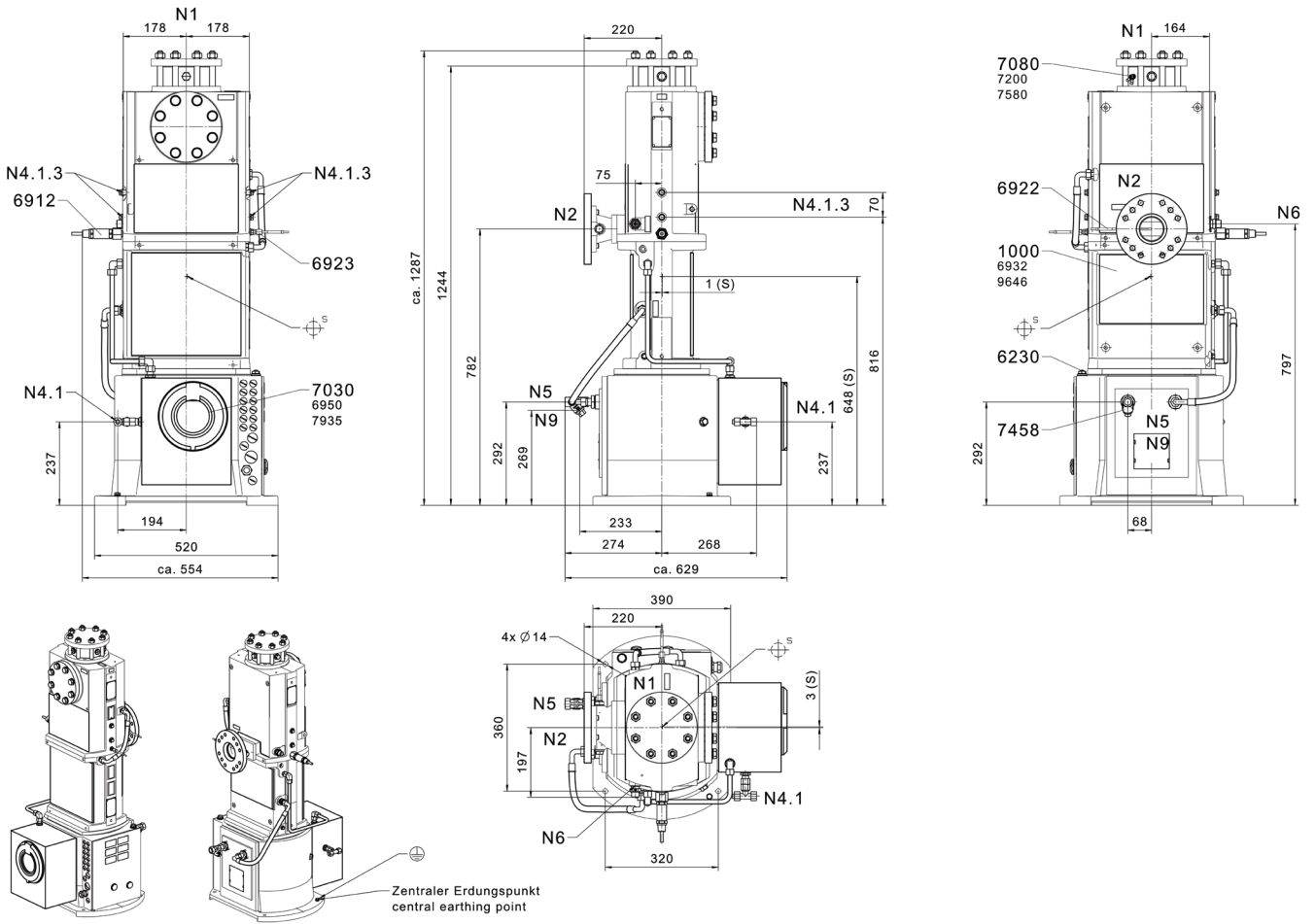

P&ID

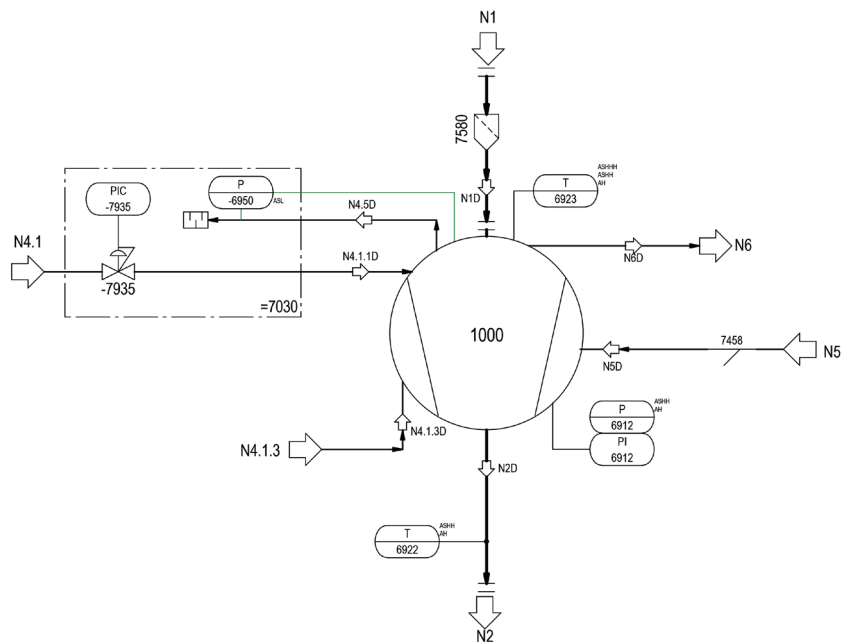

Pre-engineered systems – Configured

This system configuration provides an extended basic equipment for the operation of the vacuum pump. The scope of supply includes the following components:

Modules		Description
Vacuum pump	SIHI Dry Mi450 or Mi650	<ul style="list-style-type: none"> • Pump • Suction sieve • Integrated motors • Integrated drive control
Control	Control FX	<ul style="list-style-type: none"> • SIHI Control FX fixed-sequence control with sensor evaluation and control sequences such as Start, Stop, Warm up, Standby, Vacuum, Cleaning and Failure • Integrated communication interface
Purge gas	Purge gas system	<ul style="list-style-type: none"> • Purge gas control unit Ex-p
Base frame	Base frame	<ul style="list-style-type: none"> • Base frame with machine feet
Cooling	Secondary cooling	<ul style="list-style-type: none"> • Secondary cooling circuit with cooling pump
Shut-off valve suction	Butterfly valve	<ul style="list-style-type: none"> • Controlled, suction shut-off valve
Flushing	Threaded	<ul style="list-style-type: none"> • Controlled N₂ flush and cleaning valve
Gas dilution	Standard	<ul style="list-style-type: none"> • Controlled gas dilution module
Shut-off valve discharge	Butterfly valve	<ul style="list-style-type: none"> • Controlled discharge shut-off valve
Sensors	Thermometer pressure transmitter	<ul style="list-style-type: none"> • Evaluated Pt100 sensor in cooling jacket • Evaluated Pt100 sensor in discharge side • Evaluated pressure-side pressure transmitter • Suction-side pressure transmitter

Available communication interfaces:

I/O interface

- Digital I/O
 - Ex – p Release / Start / Stop / Reset / Operation / Failure / Warning
- Analog I/O
 - Set value speed / Vital status / Current speed value

Bus – Communication

- CANopen Slave ISO11898
- Pump control (see I/O)
- Display of operation mode

Bluetooth – Communication

- On-site operation via tablet-PC, SIHI BT remote app via Bluetooth communication and vacuum pump integrated SIHI Control FX sequence control

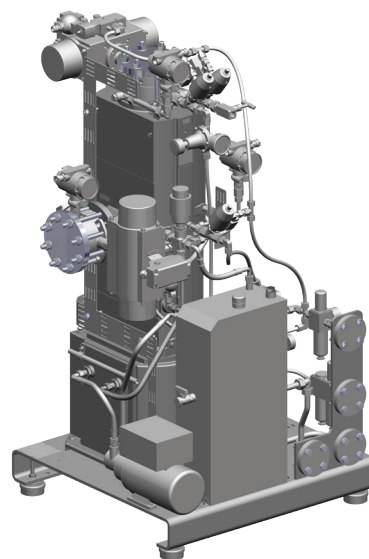

Dimensions (mm)

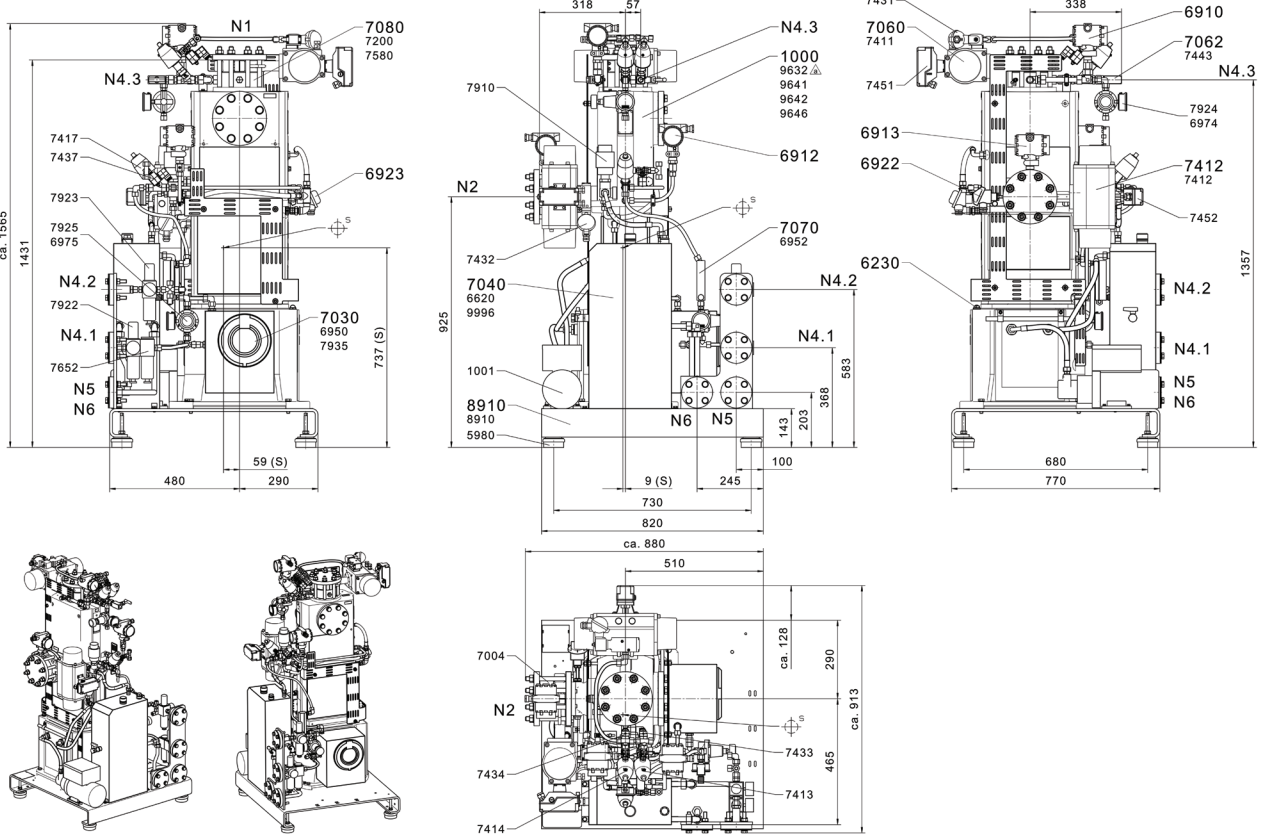

P&ID

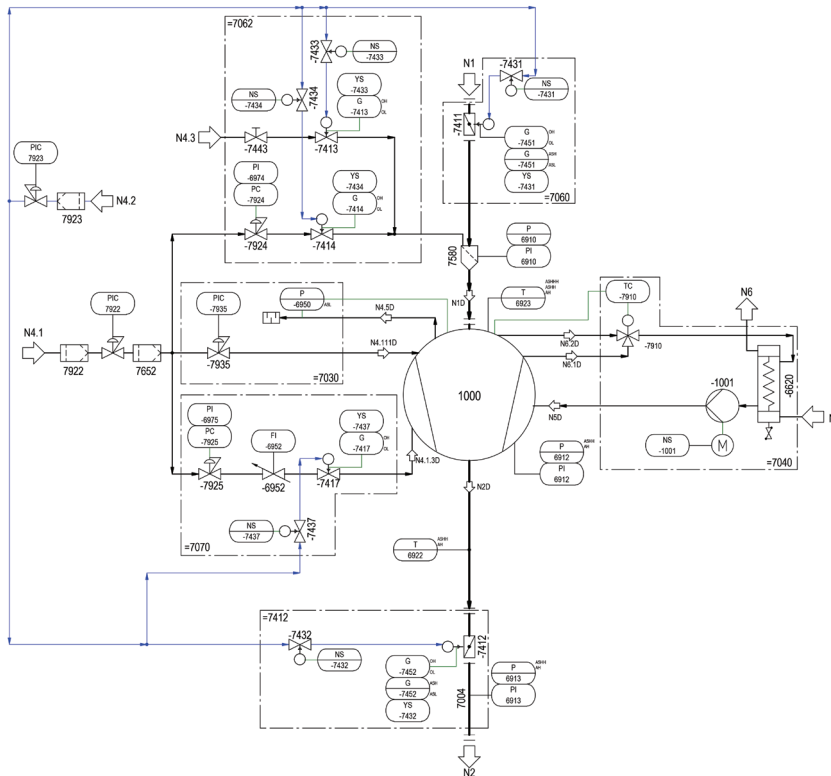

Pre-engineered systems—Premium

In addition to the extended basic equipment, this system configuration includes a supply and control unit with HMI display. This allows convenient on-site operation and visualization of the vacuum pump status. The scope of supply includes the following components:

Modules		Description
Vacuum pump	SIHI Dry Mi450 or Mi650	<ul style="list-style-type: none"> Pump Suction sieve Integrated motors Integrated drive control
Control	Control Profibus DP	<ul style="list-style-type: none"> Standard control with sequence control and sensor evaluation Programmable sequence control with different operation modes such as Start, Stop, Warm up, Standby, Vacuum, Injection Cleaning, Post Run and Failure Variable control parameters such as: Warm up Temperature / Flush Drying Time / Standby Speed Integrated communication interface
Supply unit / operation	Supply unit Protective motor switch	<ul style="list-style-type: none"> Plug-in solution with integrated transformer for 24 VDC control voltage generation to supply: <ul style="list-style-type: none"> Display control unit SIHI Dry power supply switch (Ex-p) Cooling pump motor overload switch
Purge gas	Purge gas system	<ul style="list-style-type: none"> Purge gas control unit Ex-p
Base frame	Base frame rack	<ul style="list-style-type: none"> Frame for supply unit, control unit and motor overload switch Base frame with machine feet
Cooling	Secondary cooling circuit	<ul style="list-style-type: none"> Secondary cooling circuit with cooling pump
Shut-off valve suction	Butterfly valve	<ul style="list-style-type: none"> Controlled, suction shut-off valve
Flushing	Threaded	<ul style="list-style-type: none"> Controlled N₂ flush and cleaning valve
Gas dilution	Standard	<ul style="list-style-type: none"> Controlled gas dilution module
Shut-off valve discharge	Butterfly valve	<ul style="list-style-type: none"> Controlled discharge shut-off valve
Sensors	Thermometer pressure transmitter	<ul style="list-style-type: none"> Evaluated Pt100 sensor in cooling jacket, suction and discharge side Evaluated pressure-side pressure transmitter Evaluated suction-side pressure transmitter

Pump system control with HMI display (control unit) and sequence control

- Programmed standard control with control sequences such as Start, Stop, Warm up, Standby, Vacuum, Injection Cleaning, Post Run and Failure
- Dirt detection
- Identification bearing lifetime end
- Detailed display of operation mode
- Programmable performance field

Communication interfaces

Bus – Communication

- Profibus DP (IEC 61158)
- Pump control (see control)
- Display of operation mode

On-site display

- Visualisation
- On-site operation
- Data logger

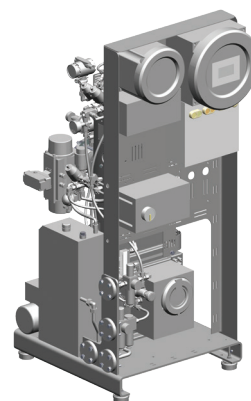

Dimensions (mm)

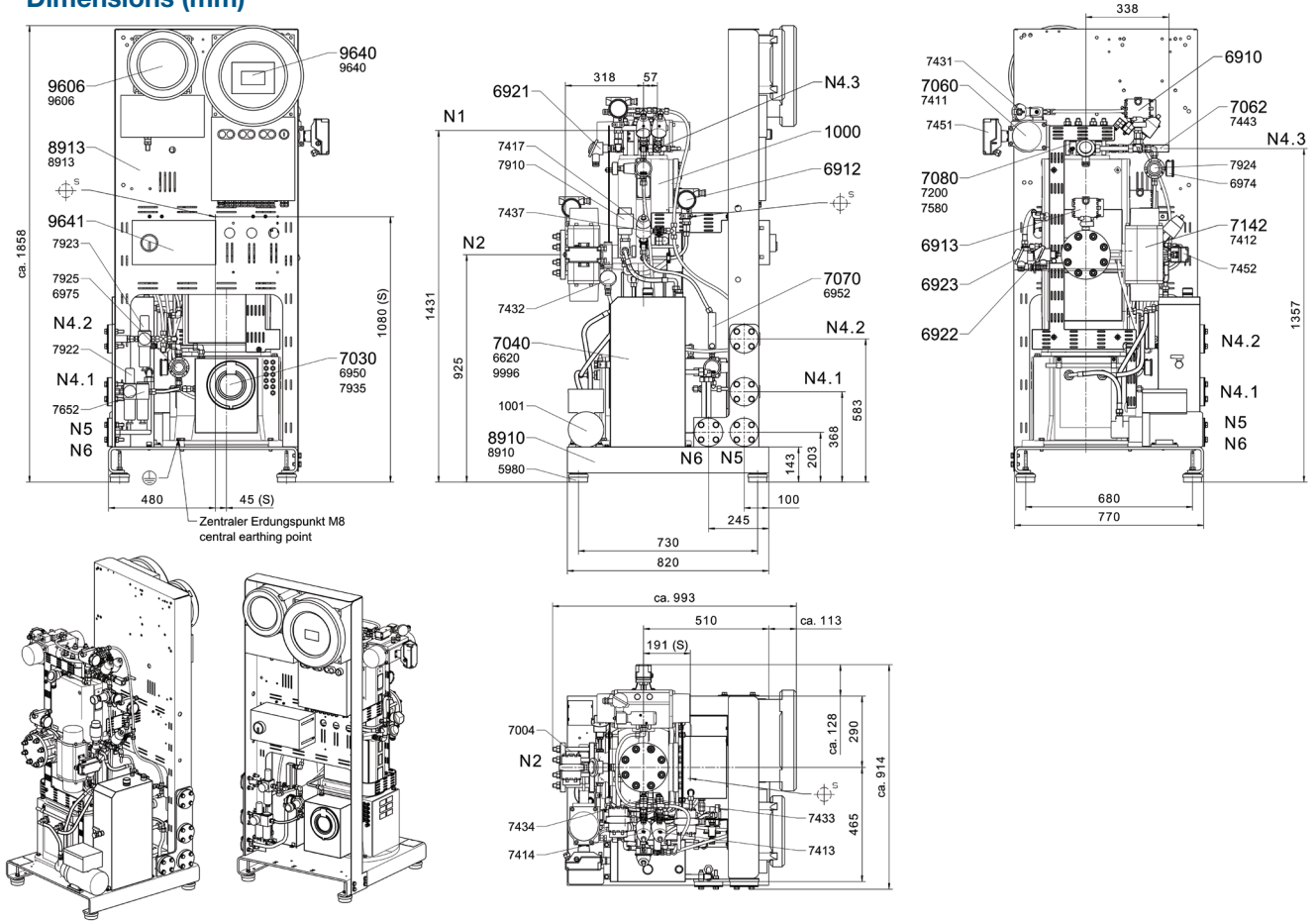

P&ID

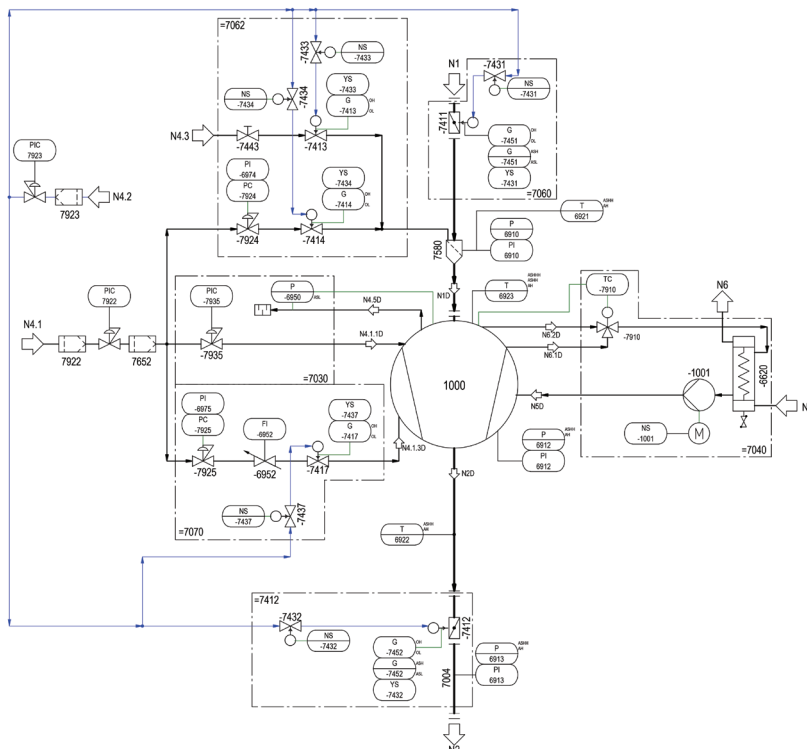

Standard modules for specific applications

SIHI Dry Mi Series vacuum pump systems can be configured from pre-engineered modules to meet exact system requirements. Numerous modules are available.

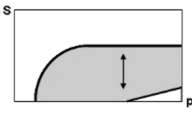
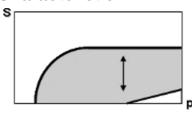
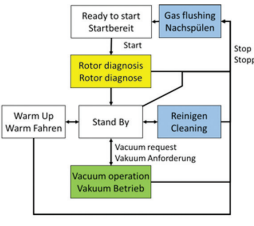

Vacuum pump	Execution	Features
<p>SIHI Dry Mi450 or Mi650</p> 	<ul style="list-style-type: none"> • Pump • Suction strainer • Integrated motors • Integrated drive control 	<p>Two screw-shaped displacing bodies rotating in opposite directions without contact</p>

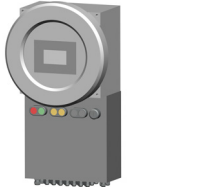
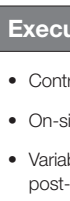
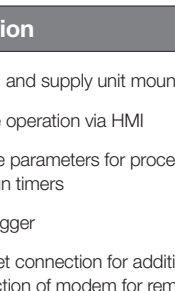

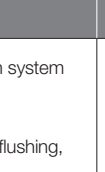
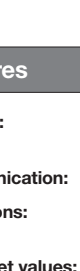
Control	Execution	Features
<p>Basic</p>	<ul style="list-style-type: none"> • Integrated in pump • Control of internal temperature • Control of torque • Electronical overload protection • On-site operation via tablet-PC, SIHI BT remote app via Bluetooth communication 	<p>Operations: Start, stop</p> <p>Status messages: Failure signal</p> <p>No valve control</p> <p>No sensor evaluation</p>
<p>Dynamic</p> <p>Characteristic:</p> 	<p>Like control variant Basic, additionally:</p> <ul style="list-style-type: none"> • Variable speed via integrated frequency converter 	<p>Operations: Start, stop, variable speed</p> <p>Status messages: Failure signal</p> <p>No valve control</p> <p>No sensor evaluation</p>
<p>SIHI Control Fx</p> <p>Characteristic:</p>  <p>Sequence chart:</p> 	<p>Like control variant Dynamic, additionally:</p> <ul style="list-style-type: none"> • On-site operation via tablet-PC, SIHI BT remote app via Bluetooth communication and vacuum pump integrated SIHI Control FX sequence control • Fixed parameter • Data logger • Detailed status messages • Control of internal temperature • Control of torques • Electronical overload protection • Integrated pressure controller • Programmed valve control (for all standard valves) • Input for digital signals • Digital status messages 	<p>Communication: Via CAN Bus</p> <p>Operations: Start, stop, vacuum, cleaning, post run</p> <p>Speed set value: Digital</p> <p>Display of operation, modes such as: No Failure, Operation Warning, Failure, Failure messages, etc.</p> <p>Valve control:</p> <ul style="list-style-type: none"> • Valve, suction side • Valve, discharge side • Gas dilution • Cleaning (liquid flushing) • Gas flushing (N₂ flushing) <p>Sensor evaluations:</p> <ul style="list-style-type: none"> • Limit switch, suction side valve • Limit switch, discharge side valve • Pressure transmitter • Temperature sensors <p>Digital inputs: Start, Stop, Vacuum, Cleaning, T_{min} (Warm up), X_{max} (Maximum value evaluation for temperature and pressure)</p> <p>Digital status messages: No Failure, Operation, Warning, Failure, Vacuum, Cleaning</p>

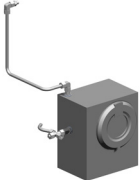
Control	Execution	Features
<p>Control Profibus DP</p>  <p>Characteristic:</p>  <p>Sequence chart:</p> 	<ul style="list-style-type: none"> Control and supply unit mounted directly on the vacuum system On-site operation via HMI Variable parameters for process optimizing as: Pre-run, flushing, post-run timers Data logger Ethernet connection for additional monitoring respectively, connection of modem for remote maintenance Detailed status messages Control of internal temperature Control of torques Electronical overload protection Integrated pressure control Programmed valve control (for standard valves) Input for digital signals Digital status messages Cooling pump control (including post-run) Cooling pump status message via bus available 	<p>Housing: Coated aluminium/ polyester resin</p> <p>Communication: via Profibus DP (IEC 61158)</p> <p>Operations: Start, stop, vacuum, cleaning, post run</p> <p>Speed set values: Digital, via Profibus</p> <p>Display of operation, modes such as: No Failure, Operation Warning, Failure, Failure messages, etc.</p> <p>Valve control:</p> <ul style="list-style-type: none"> Valve, suction side Valve, discharge side Gas dilution Cleaning (liquid flushing) Gas flushing (N₂ flushing) <p>Sensor evaluations:</p> <ul style="list-style-type: none"> Limit switch, suction side valve Limit switch, discharge side valve Pressure transmitter Temperature sensors <p>Digital inputs: Start, Stop, Vacuum, Cleaning, T_{min} (Warm up), X_{max} (Maximum value evaluation for temperature and pressure)</p> <p>Digital status messages: No Failure, Operation, Warning, Failure, Vacuum, Cleaning</p>

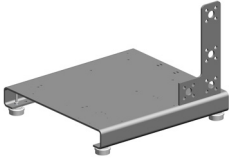
Supply unit / operation	Execution	Features
<p>Supply unit</p> 	<ul style="list-style-type: none"> Plug-in solution with integrated transformer for 24 VDC control voltage generation for display control unit SIHI Dry – Ex-p circuit switch (separation of SIHI Dry supply voltage and communication line with contactors) Wired and mounted on common baseplate Main switch (lockable) Installation of SIHI Dry and supply unit in Ex-zone 1 	<p>Housing: Coated aluminium/ polyester resin</p> <p>Electrical connection:</p> <p>Frequency: 50 Hz</p> <p>Voltage: 3 x 400 – 500 VAC, PE</p>
<p>Protective motor switch</p> 	<ul style="list-style-type: none"> Coolant pump is controlled via control unit (9X) started and stopped Motor overload switch (externally accessible) 	<p>Housing: Coated aluminium/ polyester resin</p> <p>Electrical connection:</p> <p>Frequency: 50 Hz</p> <p>Voltage: 3 x 400 – 500 VAC, PE</p>

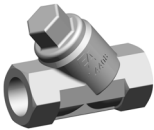

Purge gas	Execution	Features
<p>Purge gas system</p> 	<p>Motor and electronics of SIHI Dry are kept under overpressure with shielding gas. It permits pump installation within a hazardous area. The purge gas system controls the necessary operating conditions.</p>	<p>Housing: Stainless steel</p> <p>Connection: DN12 pipe fitting</p>

Base frame	Execution	Features
<p>Base frame</p> 	<p>Pump (and if applicable, the emission condenser) are mounted together on a base frame with four machine feet.</p>	
<p>Rack</p> 	<p>Additionally to base frame: Rack assembly for supply unit and control unit</p>	

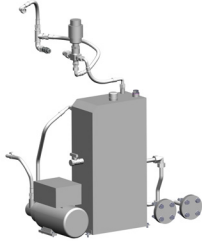
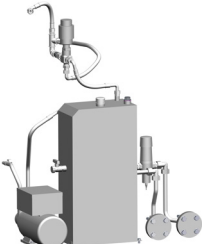

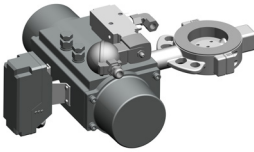
Cooling	Execution	Features
<p>Direct cooling without flanges</p> 	<p>The connection to customer's coolant system is directly connected to the pump. A strainer is installed in order to protect the pump.</p>	<p>Material execution: service side: 1.4408/brass</p> <p>Cooling water connections: 2 x G 1/2 in</p>
<p>Direct cooling</p> 	<p>The connection to customer's coolant system is realized with flanges (requires base frame).</p>	<p>Material execution: service side pipe/fittings: 1.4571/NBR</p> <p>Cooling water connections: 2 x DN25 PN40</p>
<p>Direct cooling with thermostatic valve</p> 	<p>Additionally to direct cooling: A temperature controller is installed to adapt the current demand of customer's coolant.</p>	<p>Like direct cooling, additionally:</p> <p>Material execution: service side thermostatic valve: Brass</p>

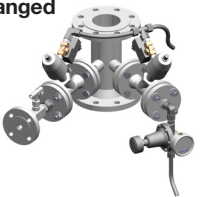
Cooling	Execution	Features
<p>Secondary cooling circuit</p> 	<p>Closed cooling loop for SIHI Dry</p> <ul style="list-style-type: none"> Internal secondary cooling loop is decoupled from customer side cooling water Protection against contamination and calcification Homogeneous tempered SIHI Dry via temperature controller 	<p>Material execution service side: Cooling loop: 1.4571 Pipe / fittings: 1.4571</p> <p>Cooling water connections: 2x DN25 PN40</p> <p>Electrical connection:</p> <p>Frequency: 50 Hz Voltage: 3 x 400 VAC, PE or 3 x 500 VAC, PE</p>
<p>Secondary cooling with thermostatic valve</p> 	<p>Additionally to secondary cooling circuit: A temperature controller is installed to adapt the current demand of customer's coolant.</p>	<p>Like D/Q, additionally:</p> <p>Material execution service side thermostatic</p> <p>Valve: 1.4581 Voltage: 3 x 400 VAC, PE or 3 x 500 VAC, PE</p>

Shut-off valve, suction side	Execution	Features
<p>Butterfly valve</p> 	<p>Isolation of the vacuum pump from the reactor:</p> <ul style="list-style-type: none"> Entry of medium into the working chamber after process is prevented Backflow through the pump and resulting ventilation of the reactor are avoided. 	<p>Scope of supply:</p> <ul style="list-style-type: none"> Valve, PFA/PTFE conductive lined Drive, designed for control pressure of 3 to 6 barg (43 to 87 psig), closed by spring energy Solenoid valve Limit switch

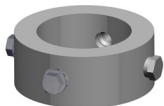

Gas and liquid flushing	Execution	Features
<p>Flanged</p> 	<p>The gas flushing using inert gas allows drying or also the discharge of residual gases from the work chamber. In addition, a liquid flush can remove particles or deposits.</p> <p>The flushing can be activated by a cleaning request, post-run or injection flushing.</p>	<p>Scope of supply:</p> <ul style="list-style-type: none"> 2/2-ways-valve, DN25, stainless steel / PTFE with drive, designed for control pressure of 3 to 6 barg (43 to 87 psig), closed by spring energy Solenoid valve Pressure reducer Needle valve
<p>Threaded</p> 	<p>Like above, but threaded connections instead of flange connections.</p>	<p>Scope of supply:</p> <ul style="list-style-type: none"> 2/2-ways-valve, G 1/2 in, stainless steel / PTFE with drive, designed for control pressure of 3 to 6 barg (43 to 87 psig), closed by spring energy Solenoid valve Pressure reducer Needle valve, stainless steel

Connection, suction side	Execution	Features
<p>Adapter</p> 	<p>Adapter for installation of sensors and/or flushing valves on suction side for systems with flame arresters.</p>	<p>Material execution: Stainless steel 1.4571</p>

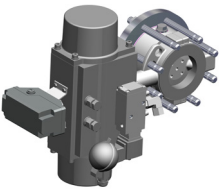
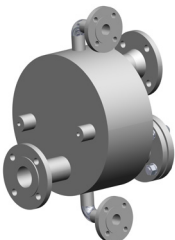
Gas dilution	Execution	Features
<p>Standard</p> 	<p>To minimize deposits and corrosion, dry inert gas (e.g., nitrogen) is injected into the working space of the SIHI Dry pump.</p>	<p>Scope of supply:</p> <ul style="list-style-type: none"> • 2/2-ways-valve, G 1/2 in, stainless steel / PTFE with drive, designed for control pressure of 3 to 6 barg (43 to 87 psig), closed by spring energy • Solenoid valve • Flow indicator (430 to 4,300 NI/h, 15.2 to 152 SCFM) with needle valve • Pressure reducer
<p>Extended</p> 	<p>To minimize deposits and corrosion, dry inert gas (e.g., nitrogen) is injected into the working space of the SIHI Dry pump.</p>	<p>Scope of supply:</p> <ul style="list-style-type: none"> • 2x 2/2-ways-valve, G 1/2 in, stainless steel / PTFE with drive, designed for control pressure of 3 to 6 barg (43 to 87 psig), closed by spring energy • 2 solenoid valves • 2 flow indicators (430 to 4,300 NI/h, 15.2 to 152 SCFM) with needle valve • Pressure reducer

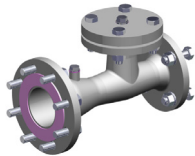
Shut-off valve, cooling discharge side	Execution	Features
<p>Butterfly valve</p> 	<p>Isolation of the vacuum pump from the exhaust line. The pump will be decoupled from the vent system and is protected from condensable media during standstill.</p>	<p>Scope of supply:</p> <ul style="list-style-type: none"> • Valve, PFA/PTFE, conductive lined • Drive designed for control pressure of 3 to 6 barg (43 to 87 psig), closed by spring energy • Solenoid valve • Limit switch
<p>Discharge condenser</p> 	<p>Discharge condenser for condensation of vapors.</p>	<p>Type:</p> <ul style="list-style-type: none"> • Plate and shell – condenser • Exchange area 1.7 m² <p>Material execution (product / service side): Stainless steel / stainless steel or Stainless steel / steel</p> <p>Connections:</p> <ul style="list-style-type: none"> • Process side: DN50/PN16 • Service side: DN25/PN16

Connection, discharge side	Execution	Features
<p>Transition pipe</p> 	<p>For connection of components on the discharge side, i.e., discharge condenser.</p>	<p>Material execution: Stainless steel</p> <p>Connections:</p> <ul style="list-style-type: none"> • Inlet: DN40/PN16 • Outlet: DN50/PN16

Sensors	Execution	
<p>Resistance thermometer</p> 	<p>Resistance thermometer (Pt100) for measuring temperature on suction side and/or</p> <p>Resistance thermometer (Pt100) for measuring coolant temperature and/or</p> <p>Resistance thermometer (Pt100) for measuring temperature on discharge side</p>	
<p>Pressure transmitter</p> 	<p>Pressure transmitter for measuring of suction pressure and/or</p> <p>Pressure transmitter for measuring dynamic pressure or exhaust pressure</p>	

Accessories	Execution	Feature
<p>Tablet</p> 	<p>Tablet or computer for control of the pump via Bluetooth for control executions: BASIC, DYNAMIC, CONTROL FX. Suitable for use in potentially explosive atmospheres.</p>	<p>Display size: 8 in</p>



Flowserve Corporation
5215 North O'Connor Blvd.
Suite 2300
Irving, Texas 75039-5421 USA
Telephone: +1 937 890 5839

PUTB000142 (EN/A4) April 2020

Flowserve Corporation has established industry leadership in the design and manufacture of its products. When properly selected, this Flowserve product is designed to perform its intended function safely during its useful life. However, the purchaser or user of Flowserve products should be aware that Flowserve products might be used in numerous applications under a wide variety of industrial service conditions. Although Flowserve can provide general guidelines, it cannot provide specific data and warnings for all possible applications. The purchaser/user must therefore assume the ultimate responsibility for the proper sizing and selection, installation, operation, and maintenance of Flowserve products. The purchaser/user should read and understand the Installation Instructions included with the product, and train its employees and contractors in the safe use of Flowserve products in connection with the specific application.

While the information and specifications contained in this literature are believed to be accurate, they are supplied for informative purposes only and should not be considered certified or as a guarantee of satisfactory results by reliance thereon. Nothing contained herein is to be construed as a warranty or guarantee, express or implied, regarding any matter with respect to this product. Because Flowserve is continually improving and upgrading its product design, the specifications, dimensions and information contained herein are subject to change without notice. Should any question arise concerning these provisions, the purchaser/user should contact Flowserve Corporation at any one of its worldwide operations or offices.

©2020 Flowserve Corporation. All rights reserved. This document contains registered and unregistered trademarks of Flowserve Corporation. Other company, product, or service names may be trademarks or service marks of their respective companies.