

Limitorque® MX Series B Smart Electric Actuator



Unmatched reliability, precision and advanced diagnostic capabilities

This document details the protection, control and monitoring capabilities of the MX range of electric actuators.

The Flowserve Limitorque MXb non-intrusive actuator consists of a mechanical gearbox powered by an electric motor.

The three-phase MXb actuator is controlled by an integral electromechanical starter and employs state-of-the-art surface mount technology (SMT) controls. Each MXb actuator is double-sealed and weatherproof to IP68 (15 m [49.2 ft] for 96 hours) NEMA 4, 4X and 6, with hazardous location versions available.

For detailed menu configurations, please refer to IOM VA10M000071.



Standard application voltages with +/- 10% nominal range

Design Voltage	Application Voltage
230 VAC, 60 Hz, three-phase	208/220/230/240 VAC, 60 Hz, three-phase
460 VAC, 60 Hz, three-phase	380/400/415/440 VAC, 50 Hz, three-phase
	380/440/460/480 VAC, 60 Hz, three-phase
525 VAC, 50 Hz, three-phase	525 VAC, 50 Hz, three-phase
575 VAC, 60 Hz, three-phase	575 VAC, 60 Hz, three-phase

* Please contact Flowserve Limitorque for other voltage requirements.

1. Standard control features

1.1 Basic specifications

The MX actuators' wiring diagrams are very similar and can be accessed at <https://limitorquedrawings.com>. This site permits a user to configure an MX actuator to their specifications. An example of a wiring diagram is shown in Figure 14.7. Optional wiring diagrams are on subsequent pages. The most current wiring diagram is located within the terminal compartment.

The following control features are included in the basic specification.

For optional features, please refer to Section 3, Optional control features.

1.2 Local control

The control panel includes a red local/stop/remote selector switch (padlock-able in all three positions; a 6 mm [0.25 in] hasp is recommended) and a black open/close rotary switch (spring-return to center). The open and close switches may be configured to allow either push-to-run (inching) control or maintained control. The rotary knob offers menu selection and configurable quick-access display.



Figure 1.1: MX actuator control panel

1.3 Local indication

The control panel includes the following:

- 240 x 160 pixel resolution LCD displays valve position as “PERCENT OPEN” and the current actuator status. Configurable temperature and ambient light control of backlight for LCD.
- Red/Green LED indicators – the color assignment for the red and green LEDs is reversible as standard.

Red ON = Valve fully open

Red “BLINKING” = Valve opening

Green “BLINKING” = Valve closing

Green ON = Valve fully closed

- Yellow LED

Yellow ON = Actuator available for remote operation.
= Valve stopped in intermediate position.

Yellow “BLINKING”

= Monitor relay de-energized; actuator not available for remote operation.

- Blue LED

Bluetooth LE option enabled and link established.

- White LED indicates over-torque.

White SOLID when torque seated, white BLINKING with over-torque fault.

The *Bluetooth*® word mark and logos are registered trademarks owned by the Bluetooth SIG, Inc. and any use of such marks by Flowserve is under license. Other trademarks and trade names are those of their respective owners.

1.4 Remote control modes of operation

The actuator may be controlled remotely by two, three or four wires.

- Four-Wire Control – Three maintained contacts for “push-and-release” control. Valve can be opened, closed or stopped.
- Two-Wire Control – One (open or closed) maintained contact for “push-and-release” control. Valve can be opened or closed, but not stopped in mid-travel.
- Three-Wire Maintained – Two maintained contacts for “push-and-release” control. Valve can be opened or closed but not stopped in mid-travel.
- Three-Wire Inching – Two momentary contacts for “push-to-run” control. Valve can be opened, closed and stopped in mid-travel.
- Refer to Figure 12.6 for remote wiring connections.

1.5 Remote control type

The actuator may be placed in digital only, modulation only, network only, or multi-command types.

- Digital (Discrete) Only Control Type – Only digital input commands are recognized and acted upon. All other types of remote control commands are ignored.
- Analog (Modutronic) Only Control Type – Only Modutronic 4-20 mA commands are recognized and acted upon. All other types of remote control commands are ignored.
- Network Only Control Type – Only network (DDC, Fieldbus, Profibus, DeviceNet, etc.) commands are recognized and acted upon. All other types of remote control commands are ignored.
- Multi-control Mode Operation – There are three modes of remote control when remote mode is configured for multi-control: digital control, analog control and network control. Digital and network control operation are based on the last command received. Analog operation is initiated by either toggling user input 2 (configure for CSE input) or breaking and reapplying the analog control.

1.6 Remote control signal power

Power for remote control signals may be derived internally from the actuator or provided externally by the user. Signals can range from 24 to 125 VAC or VDC.

1.7 External power supply

An external power supply in the range of 12 to 24 VDC may be provided by the user.

1.8 Standard internal power supply

The standard internal signal supply is 24 VDC. The 24 VDC supply offers a maximum loading of 5 W. The 24 VDC supply, in conjunction with the opto-isolated digital inputs, allows control from remote volt-free contacts over long distances and simplifies the user’s control scheme. An optional 120 VAC, 15 VA internal power supply is available (consult factory). Standard control employs a negative earth. Positive earth (negative switching) is available by wiring to the (+) positive common, as shown on the wiring diagrams.

1.9 Emergency shutdown (ESD)

Up to three independent ESD signals may be applied, prioritized and configured for different actions for the ESD event associated with each. Any of these ESD signals may be applied to the actuator to override any existing command signal and send the valve to its preselected shutdown position, providing the actuator is in Remote mode (default configuration for ESD is “Ignore, take no action”). Any new command signal will be ignored until the ESD signal is removed. During setup, the actuator may be configured to close, open, stop, take no action, or “move to a previously configured position” on receipt of the ESD signal. The ESD action may also be configured to override any inhibit signal, the local selector switch, the local stop switch, an overtorque condition, lost phase, or jammed valve protection. Motor thermal protection may be bypassed for critical ESD applications in non-hazardous or special service locations. Disabling the motor thermostat voids all third-party certifications, including Factory Mutual, IECEx and ATEX.

1.10 Remote external interlocks/inhibits

Three user-defined inputs are provided for the connection of remote contacts that will prevent motorized operation of the actuator. These are effective in both Remote and Local modes and may only be overridden by a maintained ESD signal, if so configured (refer to Figure 12.5 for wiring connections). For ESD connections, the user may select either a single common or isolated commons.

1.11 Absolute position encoder

An absolute position encoder, incorporated into MX actuators, includes 18 phototransistors, which are switched on and off by a gear/wheel mechanism. Valve position is sensed by an 18-bit, optical, absolute position encoder with redundant position-sensing circuits designed for Built-In Self-Test (BIST).

Each of the position-sensing circuits is redundant, facilitating BIST. The BIST feature discerns which failures will signal a warning only and require a warning plus safe shutdown of the actuator. Open and closed positions are stored in permanent,

nonvolatile memory. The encoder measures valve position at all times, including both motor and handwheel operation, with or without power present, and without the use of a battery. The absolute encoder is capable of resolving $\pm 7^\circ$ of output shaft position over 10,000 output drive rotations.

This design permits continuous monitoring of valve position during motor and handwheel operations. The encoder is 100% repeatable and requires no backup power source for operation. The output is used to control the open and closed valve position and measure and report valve position, as well as provide local and remote position feedback.

The positioning accuracy is better than 99% for valves requiring 50 or more turns.

- Maximum actuator turns = 10,000
- Resolution = ± 7 degrees

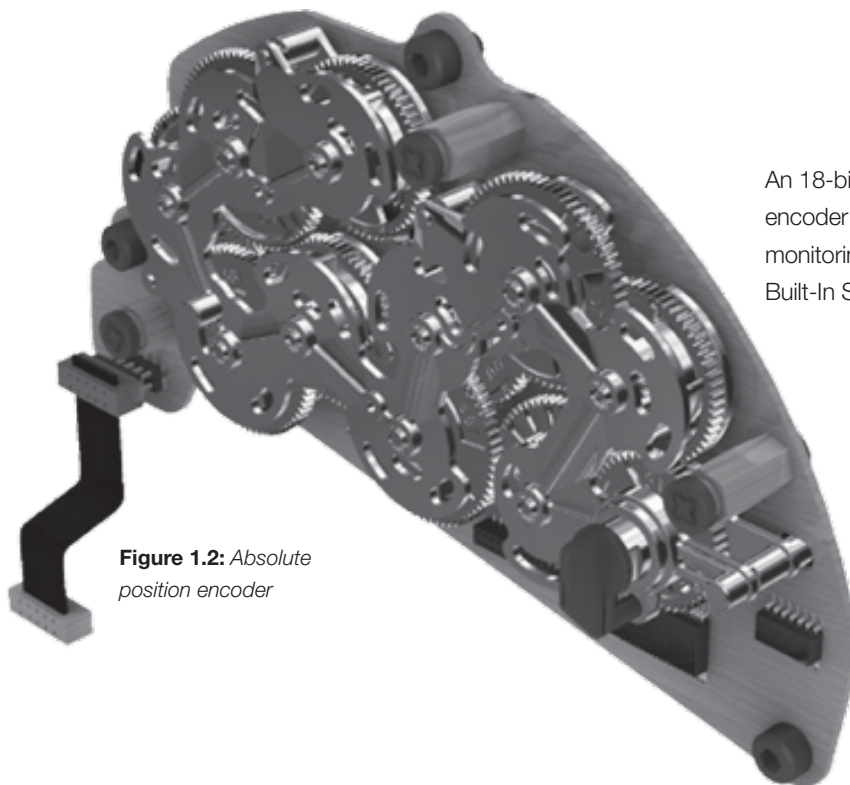

Figure 1.2: Absolute position encoder

An 18-bit optical, redundant position encoder provides continuous valve position monitoring without battery backup with Built-In Self-Test capabilities.

2. Protection features

2.1 LimiGard™ circuit protection

MX actuators include LimiGard circuit protection. LimiGard consists of dedicated circuitry that continually monitors the motor contactor, control relays, internal logic circuits and external command signals. When the recommended wiring connections are made, it virtually eliminates unexpected erroneous actuation caused by internal electronic failures and erratic external command signals. Additionally, in the event of malfunction, LimiGard supervises the actuator response, detects the source of the failure, and signals an alarm.

The voltage across the control solid-state output drivers is monitored by LimiGard. If the voltage level remains valid and no motor movement is sensed or motor contractor feedback is detected, then a motor contactor failure is diagnosed. Motor control solid-state output drivers and series-redundant, solid-state output drivers are controlled by signals that must have the proper form to permit turn-on. If either the direction driver or the safety driver is damaged, or if the drive signals do not have the proper form, then the motor contactor will not be able to turn on. Any open circuit, short circuit or component failure will alter the waveform, disabling the output and setting a monitor relay alarm. This unique protection feature prevents inadvertent, unexpected or dangerous valve movements that could otherwise occur when other circuit components fail. Additionally, LimiGard uses dual series-redundant, solid-state drivers for motor contactor control. These consist of an open or close driver and an operation enable driver. Both drivers must be on for the motor to run, but only one needs to be off to stop the valve.

The use of two drivers prevents an inability to stop the actuator due to a relay failure. All LimiGard alarms are signaled by de-energizing the monitor relay and communicated via the diagnostic screens. Valve operation is inhibited until the failure is corrected, referred to as “Fail No Action.”

LimiGard requires that external control signals (Open-Stop-Close-ESD-Inhibit) have a minimum pulse width of 250 to 350 ms to be considered valid. This minimum pulse width ensures that brief, noisy signals will not cause the valve to move. The signal must have a level of 17 to 22 V to turn on the input, and the input will not turn off until the level drops below 5 to 10 VDC. This “signal hysteresis” (> 8 VDC) prevents weak and erratic signals from stopping or initiating valve operation. Additionally, LimiGard incorporates optical couplers to protect the input circuits from high-voltage transients on the remote control signals.

The LimiGard feature may also be extended to external wiring (customer supplied). One method of securing the external wiring is shown in Figure 13.5. Proper function depends upon setting Remote Input mode to “LimiGard,” which configures redundant inputs for the OPEN, CLOSE and STOP inputs. Both OPEN or CLOSE signals must be present to allow motor motion, while loss of either STOP signal will stop the actuator and prevent further operation in REMOTE mode. The customer is responsible for external wiring system safety. LimiGard has been enhanced with the addition of the 18-bit encoder with BIST for the MX actuator with redundant sensing circuits.

2.2 Autophase protection and correction

The phase rotation of the incoming three-phase supply is continuously monitored. In the event that field wiring is reversed, three-phase MX actuator controls automatically correct to ensure the valve operates in the commanded direction. In addition, the detector circuit monitors the presence of all three phases. If a phase is lost, valve starting will be prevented and the user alerted via an LCD error message and monitor relay alarm.

2.3 Jammed valve protection

If the actuator cannot overcome the required valve starting torque, a jammed valve condition occurs. Jammed valve protection senses the lack of valve movement, further electrical operation is prevented, and the monitor relay is signaled.

2.4 Instantaneous reversal protection

The control logic incorporates a brief time delay (from 0.5 to 1.0 second) between motor reversals. This reduces motor current surges and prolongs the life of the contactor. Note: It is not necessary to switch to STOP before reversing the actuator.

2.5 Motor thermal protection

The MX actuator's motor is protected against overheating by a thermistor embedded in the motor windings. The standard thermistor threshold is set for 120°C (248°F) (Class B). Options are available for other classifications. The motor is a true bolt-on design with a quick-disconnect plug, which can be changed rapidly without sacrificing motor leads. It is equipped with a solid-state motor thermistor to prevent damage due to temperature overloads.

2.6 Preventative maintenance

Deviation and maximum levels can be enabled/disabled and configured to provide warnings of potential future failures. Deviations and maximum values are configurable to monitor torque, vibration, supply power, final position and operational values.

3. Optional control features

3.1 Modutronic

The Modutronic controller will alter valve position in proportion to an isolated analog command signal. It includes an automatic pulsing mode to reduce overshoot at the setpoint.

The following parameters may be easily set during the configuration of the unit:

- Proportional band range from 0.1 to 100% (5% = default)
- Dead band range from $\pm 0.1\%$ from nominal deadband setting to 50% (2% = default)
- Polarity 20 mA = OPEN (default) or 20 mA = CLOSE
- Action on loss of command signal OPEN, CLOSE, STOP (CLOSE = default), or Move to a previously configured position
- Delay after stop 0 to 60 seconds (0 = default)
- Command signal
- 4 to 20 mA
- Input impedance = 150 ohms
- Filter factor: filtering strength from 3 to 100 (20 = default)

Repeatability – In the three-phase MXa actuator, the Modutronic is repeatable to within $\pm 0.5\%$. Repeatability is defined as encoder feedback position versus position command. Overall valve and actuator system accuracy depends on many factors, including actuator gearing backlash and valve/actuator coupling tolerance, and therefore cannot be defined by this document.

Extrema mode – If the command signal represents a position of 0 to 2% OPEN (nominal 4.00 to 4.32 mA) or 98 to 100% OPEN (nominal 19.68 to 20 mA), then the MX actuator will move the valve directly to that position, without pulsing.

Positioning frequency – The standard frequency is suitable for a rate of 600 starts/hour for short periods, typical of process startup. Typical process control is considered to be ≤ 100 starts/hour.

Note: For modulating control on valves of less than 30-second open to close operation, please consult factory.

3.2 Analog position transmitter (APT)

The APT is an internally powered, non-contacting valve position transmitter. The isolated output signal is proportional to the position of the valve and is available as 4 to 20 mA and/or 0 to 20 mA, 0 to 10 VDC, 2 to 10 VDC, 0 to 5 VDC or 1 to 5 VDC.

The user may select the minimum signal to represent either the fully OPEN or the fully CLOSE position of the valve during the setup procedure.

- Accuracy = 99% of full-scale value (for Drive Sleeve Turns > 50)
- Non-linearity = $\pm 1\%$ of full-scale value
- Impedance = 0 to 600 ohms (4 to 20 mA signal)
- Minimum external load = 1,000 ohms (0 to 10 VDC signal)

3.3 Analog torque transmitter (ATT)

The ATT is internally powered and provides an electrically isolated output signal of 4 to 20 mA and/or 0 to 20 mA, 0 to 10 VDC, 2 to 10 VDC, 0 to 5 VDC or 1 to 5 VDC, which is proportional to actuator rated output torque.

- Accuracy = 99% of full-scale value
- Non-linearity = $\pm 1\%$ of full-scale value
- Impedance = 0 to 600 ohms (4 to 20 mA signal)
- Minimum external load = 1,000 ohms (0 to 10 VDC signal)

3.4 Two-speed timer

A two-speed pulsing timer can be enabled to extend the operating time in the close and/or the open directions. Pulsing may be applied from 0.5 (if precision is set to xxx.x%) to 99% of full valve travel or to a small portion. The ON pulsing cycle is configurable from 0.5 to 20 seconds in 0.5-second increments, and the OFF pulsing cycle is configurable from 1.0 to 200 seconds in 1-second increments. The two-speed timer is especially effective where concerns of hydraulic shock exist.

3.5 Control station (CSE)

The CSE is a separate control station designed for the operation of inaccessible actuators. It is available with LEDs, remote/local and open/close selector switches. The CSE may be powered by the actuator internal supply, provided wire resistance and other external loads do not limit the available signal power presented to the MX actuator.

3.6 Isolation and load break switches

Isolation and load break switches can be supplied for the incoming three-phase supply to the actuator. These may be coupled directly to the actuator for weatherproof (WP) applications only or separately for mounting by the user. The enclosure is suitable for weatherproof or temporary submersion service. An explosion-proof (XP) isolation switch is also available for user mounting. It is suitable for mounting with all MX actuators. Please contact factory for availability.

3.8 Custom software – momentary contact

ESD and partial stroke ESD

An optional, custom software has been developed which, when combined with the unique safety features of the MX actuator, permits a unique scope of performance for partial stroke and emergency shutdown installations.

When enabled, a user may set up the partial stroke and ESD signals as redundant digital inputs for safety. There are two signal inputs for either selection, and both must be in the active state in order for the specific function to occur.

If the partial stroke enable inputs are not active, in a fault state, or are released by the control logic and a signal is detected on the momentary ESD/PSESD input, then the actuator will perform the configured ESD operation. The momentary ESD/PSESD input will be ignored if there is a signal present for less than 100 msec, and is guaranteed to latch in the ESD/PSESD if the signal is present for greater than 800 ms. ESD is active until the control logic ESD release is given.

3.9 Custom software mode #2 – momentary contact ESD and CSE

Custom software is available for the MX actuator that permits the user to establish certain performance characteristics, momentary contact closure ESD and four-wire remote control.

The ESD release signals are set up as redundant signals for safety. There are two signal inputs, and BOTH must be in the active state. If there is an active ESD and both ESD release inputs are in the active state, the ESD will be unlatched and the unit will return to normal operation. If the ESD release inputs are in a fault state, an active ESD will NOT be released.

The ESD release inputs will have no effect on a partial stroke ESD test. The momentary ESD input will be ignored if there is a present for less than 100 ms, and is guaranteed to latch in the ESD if the signal is present for greater than 800 ms. Once the ESD is latched in, the unit will perform the ESD action. In this case, the ESD will move the unit to the close limit and remain in ESD mode until the ESD release indication is given using the ESD release inputs.

3.10 Custom software mode #3 – ESD time delay relay

The ESD time delay relay input (input 0) functions like any normal ESD input signal. Only if a time has been entered into the delay timer value then the unit will not act on that ESD for that delayed amount of time. If the ESD signal is removed, then the timer is canceled and will start fresh with the next assertion. You cannot change that input 0 is ESD, but it can be enabled/disabled, set to signal present/absent, or you can change the ESD action.

3.11 Custom software mode #4 – multi-position mode

The custom input multi-position mode allows the user to configure up to two mid-travel stop positions. The user will be able to send the actuator to either of these positions in either remote or local controls. In order to use local controls in multi-mode, that option will need to be selected in the CHANGE LOCAL control menu. The user can select any of the standard wire controls for inputs 3, 4 and 5 (four-wire, three-wire maintain, or three-wire inching).

Please contact factory for application and purchase.

3.12 Custom software mode #5 – local lockout

The custom input local lockout mode allows for input 0 to function as a lockout to restrict operation from the local knobs when the red selector switch is in local. A warning will display if the input is active and the knob is in local to alert the user the mode is active. The red knob will still respond if moved to STOP or REMOTE.

4. Network communications

The MX actuator provides a comprehensive network option portfolio to the user. The MXb smart actuators provide the user with predictable, reliable and safe operation for years to come, in applications which are subject to the most rigorous requirements and environmental extremes.

With each of the provided network protocols, a user may configure the unit to move to a predefined fail-safe position on loss of communication. Action on loss of command signal OPEN, CLOSE, STOP or MOVE-TO preconfigured position. The user may also configure the length of time communication must be lost before the unit indicates communication loss and performs the communication loss action.

Please see Section 13 for network connection topologies and cabling recommendations.

4.1 DDC (Distributed Digital Control) communication — Modbus™

DDC is Flowserve Limitorque's digital communication control system that provides the ability to control and monitor up to 250 actuators over a single twisted-pair cable. The communication network employs Modbus protocol on an RS-485 network and is redundant. Redundancy assures that any single break or short in the communication cable will not disable any actuators. Each actuator has included an addressable field unit that communicates over the twisted-pair network and executes open, close, stop, ESD and GO TO position commands. The field unit also communicates all actuator status and alarm diagnostic messages over the same communication network.

DDC Network

- Single-ended loop (as standard – see Figure 13.1)
- Modbus protocol
- High-speed – up to 19.2k baud

4.2 Master Station IV

MX actuator units equipped with DDC can be controlled via Flowserve Limitorque's Master Station IV. It includes:

- Host interface – Industry standard Modbus RTU, ASCII and TCP/IP protocols
- 6.5 in TFT touch-screen display for network configuration/status

- Network control of up to 250 devices
- Configurable polling sequence priority
- Network time protocol for time synchronization of alarms/diagnostics data to host device
- Modules can operate independently or be externally coupled to form redundant communications.
- Email notifications of alarm conditions
- Data/event logging
- Redundant RS-485 network ports
- High-level surge protection on network
- Front access to peripheral ports: ethernet, USB x 2, VGA, printer/debug

4.3 Foundation Fieldbus communication

MX actuators can be fitted with Foundation Fieldbus protocol that complies with the IEC 61158-2 Fieldbus H1 standard. The field unit device is able to support several topologies, such as point-to-point, bus with spurs, daisy chain, tree, or a combination of these. The FF device has network features that include:

- Link active scheduler (LAS), which controls the system
- High-speed communications up to 31.25 k bits/sec
- Publisher-subscriber communication
- One analog input block, one analog output block, two discrete output function blocks, transducer block, resource block, and four discrete input function blocks
- Device descriptions
- Configurable by user

Link active scheduler communication: Fieldbus segments have one active LAS at a given time, which is the bus arbiter, and does the following:

- Recognizes and adds new devices to the link
- Removes non-responsive devices from the link
- Schedules control activity in, and communication activity between, devices
- Regularly polls devices for process data
- Distributes a priority-driven token to devices for unscheduled transmissions

4.4 Profibus DP V1 Communication

MX actuators can be optioned with a Profibus DP-V1 network interface that complies with EN 50170 Fieldbus Standard for RS-485 communications. The interface supports daisy chain topology with non-redundant, flying (single or two-line), or system redundancy. The Profibus DP interface has network features that include:

- High-speed communication up to 1.5 mbits/sec
- Support for DP-V0 (cyclic) and DP-V1 (asyclic) protocols
- Single or dual channel operation
- Redundant Profibus DP with single or multi-master communications
- Support for extended packet information
- Support for 63 or 126 addresses per network, depending on redundancy options
- Device description file (GSD) with configurable parameters

4.5 Profibus PA communication

A Profibus PA protocol is available and complies with EN50170 Fieldbus Standard and Fieldbus physical layer per IEC 61158-2 for communications. The device supports several topologies such as point-to-point, bus with spurs, daisy chain, tree, or a combination of these. The PB device has network features that include:

- High-speed communications up to 31.25 k bits/s with Manchester coding
- Master-to-slave communication
- Bus powered for 9 to 32 VDC and 15 mA per actuator
- One analog in and one analog out, four digital input, and up to eight digital output function blocks
- Device description file describes device and parameters

4.6 Device type manager (DTM) for Profibus DP/PA and Foundation Fieldbus

A software component which can be downloaded from www.limitorque.com and integrated into Field Device Tool (FDT) frames for:

- Offline/online parameterization
- Configuration
- Status updates
- Diagnostic retrieval
- Actuator health

4.7 DeviceNet communication

DeviceNet complies with CAN-based protocol and provides the following features:

- DeviceNet Group 2 Server implementation
- Bus-powered network interface allows power alarm information to be communicated when actuator loses main power. The actuator does NOT drop off the network when three-phase power is lost.
- Standard polled I/O connection
- Standard bit strobed I/O connection
- Standard change of state/cyclic I/O connection
- Standard explicit connections defined as:
 - Various assembly objects and sizes that allow the network user to determine how much data to transfer to accommodate network installation data throughput requirements
- Automatic BAUD rate detection
- Node address configurable via local setup menu, or via the remote network user
- Broadcast or group network originated ESD support

4.8 HART communication with DTM

- Complies with HART Communication Protocol Specification (Document HCF_SPEC-13) for Revision 7.3
- Digital signal on conventional 4 to 20mA analog signal
- 1,200 bps binary phase — continuous frequency-shift-keying
- Master-slave communication method
- Point-to-point or multi-drop network topology
- Distances up to 1,800 meters/network (up to 15 devices)
- EDDL (IEC 61804-2, EDDL) with methods for all supported common practice and device-specific commands

5. Monitoring and diagnostic facilities

5.1 Local facilities

LCD displays – The LCD displays an array of data concerning the status of actuator components in clear, graphical or textual language. The MX actuator is available with 11 languages: English, Spanish, German, French, Italian, Portuguese, Mandarin, Russian, Turkish, Bahasa Indonesia and Katakana.

Normal display – The normal display illustrates current valve position, torque, demand and status. Complexity of the standard screen is configurable. The display also can be configured to show valve status symbols instead of percentage open.

Quick access – During normal operation, the rotary knob can be configured to display live data, diagnostics and graphs when turned clockwise or counterclockwise. See IOM VAIOM000071 for configuration options.

Alarm functions – Alarm functions (active alarms will be toggled every four seconds) that may be displayed include:

- “---% OPEN, STATUS OK” – normal display
- “---% OPEN, VALVE JAMMED” – valve cannot start moving
- “---% OPEN, LOST PHASE FAULT” – one of three phases lost
- “---% OPEN, MOTOR OVERTEMP” – thermistor range exceeded
- “---% OPEN, OVERTORQUE” – torque exceeded in mid-travel
- “---% OPEN, HARDWARE FAILURE” – general indication
- “---% OPEN, DDC OFF” – DDC enabled, but off
- “---% OPEN, FF OFF” – FF enabled, but off
- “---% OPEN, PBDP OFF” – PB/DB enabled, but off
- “---% OPEN, PBPA OFF” – PB/PA enabled, but off
- “---% OPEN, DN OFF” – DeviceNet enabled, but off
- “---% OPEN, NO ANALOG SIGNAL” – 4-20mA signal absent (Modutronic enabled, red selector knob in “REMOTE”)
- “---% OPEN, DDC COMM LOSS” – DDC enabled, signal absent
- “---% OPEN, FF COMM LOSS” – Foundation Fieldbus enabled, signal absent
- “---% OPEN, PROFIBUS COMM LOSS” – Profibus DP enabled, signal absent
- “---% OPEN, PBPA COMM LOSS” – Profibus PA enabled, signal absent
- “---% OPEN, DN COMM LOSS” – DeviceNet enabled, signal absent
- “---% OPEN, PLC OFFLINE” – the PLC has stopped communicating with the actuator
- “---% OPEN, THERMISTOR FAULT” – there is a failure with the motor thermistor
- “---% OPEN, KNOBS” – there is a failure with the local knobs
- “---% OPEN, LEFT KNOB FAIL” – there is a failure with the red selector knob
- “---% OPEN, RIGHT KNOB FAIL” – there is a failure with the black control knob
- “---% OPEN, CENTER KNOB FAIL” – there is a failure with the menu knob
- “---% OPEN, CONTACTOR FAULT” – contactor failure
- “---% OPEN, ENCODER FAULT” – encoder failure
- “---% OPEN, R1R4RM IO BOARD” – R1-R4 board relay check failed
- “---% OPEN, R5R8 IO BOARD” – R5-R8 board relay check failed
- “---% OPEN, DDC BOARD” – DDC board communication with the host controller failed, or hardware fault
- “---% OPEN, FF BOARD” – Foundation Fieldbus board communication with the host controller failed, or hardware fault
- “---% OPEN, PB DP BOARD” – Profibus DP board communication with the host controller failed, or hardware fault
- “---% OPEN, PB PA BOARD” – Profibus PA board communication with the host controller failed, or hardware fault
- “---% OPEN, DN BOARD” – DeviceNet board communication with the host controller failed, or hardware fault

- “---% OPEN, HART1 BOARD” – HART board 1 communication with the host controller failed, or hardware fault
- “---% OPEN, HART2 BOARD” – HART board 2 communication with the host controller failed, or hardware fault
- “---% OPEN, ENCODER WARNING” – the encoder has not yet failed, but there was a momentary glitch detected; if the glitch persists, encoder failure will be reported
- “---% OPEN, ESD XX ACTIVE” – input XX is set for ESD, is asserted, and has highest priority
- “---% OPEN, ESD CONFLICT” – input is set for ESD, is asserted, and is in conflict with the active ESD
- “---% OPEN, INHIBIT ACTIVE” – inhibit signal is asserted
- “---% OPEN, INH CONFLICT” – conflict with multiple inhibits
- “---% OPEN, IDENTICAL LIMITS” – position limits identical, preventing operation
- “---% OPEN, TORQUE TIMEOUT” – the torque switch timed out after the actuator determined that it has reached its torque seat
- “ANALOG OUT 1 LOSS” – analog board output driver chip is reporting a fault and cannot be reset, resulting in loss of analog out signal
- “ANALOG OUT 2 LOSS” – analog board output driver chip is reporting a fault and cannot be reset, resulting in loss of analog out signal

RAM error

The MX actuator’s processor continually checks RAM for memory corruption errors. If corruption is detected, the processor will force a reset to clear RAM. The LCD will temporarily display the following prior to this reset:

- “---% OPEN, RAM ERROR”

After the reset, the display will read normally. Any momentary commands (DDC command, momentary push-button, etc.) that were not completely executed must be reissued.

ROM error

The MX actuator’s processor continually checks EPROM for memory corruption errors. If corruption is detected, operation is disabled. If the red selector knob is in “LOCAL” or “REMOTE”, the LCD will display the following:

- “---% OPEN, ROM ERROR”

When the red selector knob is placed in “STOP”, the unit will require reinitialization.

“SET LIMITS” – Normal display if red selector knob is in “LOCAL” or “REMOTE” and position limits have not been set

“INITIALIZE” – “INITIALIZE” will be displayed if module has no actuator configuration. No operation will be permitted until initialization has been completed. See Figure 5.1.

5.2 Diagnostics

Standard diagnostic screens – Diagnostic screens may be accessed quickly through the Setup dialogue. These screens provide detailed data of actuator status. Included are:

- **Alarms and warnings** – Provide live indications for faults, alarms and warnings. Alert a user to issues with installed hardware (encoder, knobs, memory, etc.), operation (over-torque, lost phase, over-temp, etc.) and warnings (low battery, starts/hour or vibration ratings exceeded).
- **Rated vibration exceeded** – Displays the duration and level of an exceeded vibration rating event by time-stamping the start and end points of that event along with occurrence counts and captured value.
- **Live diagnostic snapshots** – Menus are available to display the current configuration and status values for digital and analog inputs and outputs, network (if installed), partial stroke test, real-time clock, Bluetooth, motor and the supply power.
- **Identification** – Tag number, serial number, order number, software revision
- **QA data** – Serial number for HC and UI boards, date and time last unit tested on Limitorque EOL stand

5.3 Analytics

The analytics menu provides live statistics on the actuator's status and performance. Upon entering the analytics menu, the following menu items will be displayed:

- **Torque** – Torque analysis provides graphs and data for the most recent and referenced torque profiles along with the digital display of torque averages during breakout, seating and mid-stroke. This menu gives a user the ability to save the most recent torque profile to be the reference profile.
- **Position** – Position analysis displays run time vs. position, starts/hour vs. position, and deviations in 0 and 100% positioning.
- **Vibration** – Vibration analysis shows maximum and average vibration vs. time graphs viewable for up to 10 years of data, maximum/minimum/average/current vibration levels vs. position, and vibration histograms. Vibration vs. position data allows for the saving of reference data for historical tracking.
- **Motor/Internal Temp** – Temperature vs. time displays viewable information spanning from hours to years of data tracking for motor and internal compartment temperature readings.

5.4 Data logs

The data logs provide real-time clock, time-stamped data of the actuator's status and performance.

- **Event logs** – Allow for the configuring and selection of alarms and events categorized by the NAMUR NE 107 standard. This event log tracks the maintenance, out of spec, function check and failure notifications by providing the date, time and fault.
- **Actuator logs** – Track and log all actuator movement commands. Updates added to the log include movement commands, demand updates, setpoint reached and interruptions to the actuator movement.
- **Statistics logs** – The statistic logs provide users maximum and minimum time-stamped recordings of statistical data such as temperatures, torques, operational counts, trips and supply power.
- **Service logs** – Menu options allow a user to view current operational count data such as run time, contactor operation counts, seating counts, over-torque counts, etc. The service log menu also allows for service operators to time-stamp the date and time the actuator was last serviced.
- **Partial stroke log** – Provides users a time-stamped log of run partial stroke tests. This menu option provides the torque profile of the partial stroke run as well as feedback for any faults that may have occurred during this test.

5.5 User indicators

This menu provides the user with the abilities to enable, set and view deviation and maximum levels in order to promote greater insights into the application and provide process performance monitoring by warning the operator of potential future failures before they occur. Deviations are configurable for torque, final position, vibration and operational data such as hunting, drive sleeve turns and operations. Service time intervals can also be configured to alert the user of a timed service notification.

6. Remote facilities

6.1 Actuator status contacts (S1, S2, S3, S4)

Four latched contacts provide remote feedback of actuator status. These contacts may be individually configured for normally open, normally closed, or blinker (continuous opening and closing of the valve) operation and provide feedback of one of the functions listed below.

The contacts are rated 5.0 A at 250 VAC, 30 VDC. The total combined current through all four status contacts must not exceed 8 A.

Actuator Status Message	Function
"CLOSED"	- valve closed "(0% OPEN)"
"OPENED"	- valve open "(100% OPEN)"
"CLOSING"	- valve closing
"OPENING"	- valve opening
"STOPPED"	- valve stopped in mid-travel
"VALVE MOVING"	- either direction
"LOCAL SELECTED"	- red selector knob in "LOCAL"
"MOTOR OVERTEMP"	- thermistor range exceeded
"OVERTORQUE"	- torque exceeded in mid-travel
"MANUAL OVERRIDE"	- actuator moved by handwheel
"VALVE JAMMED"	- valve can't move
"CLOSE TORQUE SW"	- torque switch trip at "CLOSED"
"OPEN TORQUE SW"	- torque switch trip at "OPEN"
"LOCAL STOP/OFF"	- red selector knob at "STOP"
"LOST PHASE"	- one or more of the incoming supply lost
"ESD SIGNAL"	- signal active
"CLOSE INHIBIT"	- close inhibit signal active
"OPEN INHIBIT"	- open inhibit signal active
"ANALOG IP LOST"	- 4 to 20 mA not present
"REMOTE SELECTED"	- red selector in "REMOTE"
"HARDWARE FAILURE"	- indication
"NETWORK CONTROLLED"	- permits relay control via DDC, FF, or other network driver
"FUNCTION"	- LimiGuard circuit protection activated
"STARTS/HR EXCEEDED"	- number of motor starts per hour exceeded
"NETWORK COMM LOSS"	- network communication has been interrupted
"LOCAL OPERATION"	- unit is being operated locally (red selector knob is in LOCAL and black control knob is in OPEN or CLOSE)
"REMOTE OPERATION"	- unit is being operated remotely by digital inputs OPEN or CLOSE
"RUN LOAD HIGH"	- exceeded run load maximum warning threshold
"DPTS OPEN"	- open torque switch trip (open torque seat or open overtorque)
"DPTS CLOSE"	- close torque switch trip (close torque seat or close overtorque)
"MID-TRAVEL"	- valve position, 1 to 99% open
"CSE CONTROL"	- CSE station in LOCAL or STOP and controls actuator
"PS ACTIVE", "PS PASSED", "PS FAILED TARGET", "PS FAILED RETURN"	- "PS" - partial stroke, activated if PS is configured

Default settings are:

Status contacts

- S1 – normally closed contact at valve fully CLOSED
- S2 – normally closed contact at valve fully OPENED
- S3 – normally opened contact at valve fully CLOSED
- S4 – normally opened contact at valve fully OPENED

Alarm contacts (optional; requires I/O board)

- R5 – MOTOR OVERTEMP
- R6 – REMOTE SELECTED
- R7 – OVER-TORQUE
- R8 – VALVE JAM

6.2 Monitor relay (SM and RM)

The monitor relay provides immediate indication of problems that prevent remote valve operation. It has a normally open contact and a normally closed contact (1 x SPDT contact) and is energized when the three-phase supply is present and the actuator is in a normal/healthy state.

The relay will de-energize if any of the following events occur:

- Loss of one or more phases of the three-phase power supply
- Loss of internal control supply
- Jammed valve detected
- Motor overtemp is active (unless thermostat is configured to OFF)
- During configuration, the following parameters may be added or removed to the monitor relay function:
 - Selector switch is in “Local” mode
 - Selector switch is in “Stop” position
 - Over-torque
 - Inhibit signal active
 - ESD signal active (The user can enable or disable “local” mode and “stop” position. Default is enabled.)

The monitor relay resets when the faulty state is rectified.

6.3 Optional alarm status contacts (R5, R6, R7, R8)

As an option, up to four additional latched status contacts may be included. These may be configured in an identical manner to the S contacts or differently, depending upon user configuration.

Default configurations are:

- R5 – Closed contact when motor over temperature
- R6 – Closed contact when remote selected
- R7 – Closed contact when over-torque
- R8 – Normally open contact when analog I/P (input) lost

The contacts are rated 5.0 A at 250 VAC, 30 VDC.

6.4 Exact end position indication

On torque-seated valves, the end-of-travel indication switch trips when the required torque is achieved at the end of travel — not at the calibrated position limit. This ensures that remote, self-latched signals will not be disconnected prematurely, and that the valve will be tightly seated.

7. Auxiliary power supply — uninterruptible power supply (UPS) connection

If the main power supply is not available during the commissioning of the actuator, users may connect a 24VDC, 1A power source to the auxiliary input terminals, as shown in the wiring diagram on the following pages, to power the actuator for setup and feedback only. Power supply will draw up to 0.5 A.

8. Isolated commons

The MX actuator is provided with isolated commons for control functions. Please refer to wiring diagram on page 29 for locations.

9. Bluetooth LE wireless communications

Bluetooth capabilities permit a user to download firmware updates via a standard low-power wireless communication path to an actuator. The MX actuator can communicate via Bluetooth with a Bluetooth LE-equipped PC. Bluetooth contains a frequency-hopping spread spectrum (FHSS), which enables a reliable communication link, even in a “noisy” environment. Bluetooth also contains 128-bit data encryption to protect the privacy of the link. Bluetooth communication is accessible up to 10 m (32.8 ft) from the actuator in all directions and the ability to enable the Bluetooth communication link is password protected. A visible blue LED in the controls LCD window signifies that an active Bluetooth link to the actuator is established.

The Bluetooth LE capabilities will enable future suites of tools and additional feature content. It also ensures compatibility with present and future Bluetooth-enabled devices.

These features are available up to 10 m (32.8 ft) from the actuator equipped with the Bluetooth option.

10. Actuator configuration

10.1 Non-intrusive local configuration

MX actuators may be configured without removing any covers or using special tools. Configuration is accomplished through the use of the LCD and the local control switches mounted on the control panel. Settings that can be initiated or changed include:

- Limit switch trip positions
- Torque output levels
- Direction of rotation
- Action on ESD
- External inhibits
- Remote control operating mode
- Motor thermostat action
- Stop valve on torque or position
- All optional features (Modutronic, DDC, FF H1, PB-DPV1 and redundant PB-DPV1, PB- PA, DeviceNet, HART, Timers, APT, etc.)

10.2 Default configuration

Unless otherwise specified, MX actuators will be shipped with the following configurations, which become effective after limits are set:

- Open stop by limit
- Close stop by limit
- Maintained local controls
- Clockwise to close
- ESD is “off” and set to “IGNORE”
- Inhibits enabled, turned “OFF”
- Remote control – three-wire maintained and multi-mode
- Password: If you need a username or password reset, please contact your local Flowserve sales/service engineer
- Modutronic option (if enabled)

<p>Modutronic Option</p> <p>Proportional band – 5%</p> <p>Deadband – 2%</p> <p>Polarity – 20 mA = Open</p> <p>Action on loss of signal = Close</p>	<p>Modbus RTU protocol</p> <p>9,600 baud</p> <p>Analog scale = 0 to 100</p> <p>Proportional band – 5%</p> <p>Deadband – 2%</p> <p>Offset – 0 mA</p>
<p>FF Option, DeviceNet and PB Option</p> <p>Analog scale = 0 to 100</p> <p>Proportional band – 5%</p> <p>Deadband – 2%</p>	

Figure 10.1: Default configuration guidelines

Configuration screens are displayed in English. Languages such as Spanish, French, German, Italian, Portuguese, Mandarin, Russian, Bahasa Indonesia (Malay), Turkish and Katakana are also available and can be configured via the actuator control panel.

A three-digit numeric password is included as part of the initial setup procedure to prevent unauthorized changing of the configured parameters. If the password is entered incorrectly, settings may be viewed, but not changed.

11. Specifications

The MX actuator is the most rigorously tested non-intrusive actuator in the industry; it complies with all pertinent global requirements. Please contact the factory should your requirements exceed the listed parameters.

11.1 Global certifications

Standard non-hazardous certifications — The normal operating temperature range for weatherproof applications is from -20°C to 65°C (-22°F to 149°F).

- FM – NEMA 3, 4, 4X and 6
- IEC – IP 68 to 15 m (49.2 ft) for 96 hours
- Submersion – NEMA 6 (1.8 m [6 ft], 30 min), IEC529, IP68 (15 m [49.2 ft] 96 h Limitorque specification (6.1 m [20 ft] 24 h)
- Saliferous (salt) spray – 2,000-hour test per ASTM B117-1985

Standard explosion-proof certifications — The normal operating temperature range for explosion-proof applications is from -20°C to 65°C (-22°F to 149°F).

- FM – Class 1, Division 1, Group B, C and D. Class II/III, Division 1, Group E, F and G – T4
- ATEX – Eex d IIB T4 ATEX II 2 G, CENELEC Norm EN50014 and EN50018
- Eex d IIC T4 ATEX II 2 G, CENELEC Norm EN50014 and EN50018
- Eex de IIB T4 ATEX II 2 G, Increased Safety, CENELEC Norm EN50014, EN50018, EN50019
- Eex de IIC T4 ATEX II 2 G, Increased Safety, CENELEC Norm EN50014, EN50018, EN50019
- IECEx – Ex d IIB T4 & Ex de IIB T4 and Ex d IIC T4 and Ex de IIC T4
- IECEx – Eexd IIB T6 & Eexd IIC T6 and Eexde IIB T6 and Eexde IIC T6

11.2 Wiring

- All internal wiring is flame-resistant, rated -40°C to 105°C (-40°F to 221°F), and UL listed.

11.3 Valve interface

- Mounting base conforms to MSS SP-102 or ISO 5210 as required. Steel torque bushings (type B) and bronze thrust nuts (type A) are removable for machining.

11.4 Design life and endurance

- **Design life** – 1 million drive sleeve turns is considered typical life expectancy under normal operating conditions in approved ambient working environments.
- **Endurance** – 50 million collective drive sleeve turns of endurance testing were performed on the MX actuator for proof of design.
- **AWWA C540-02** – “Standard for Power Actuating Devices for Valves and Sluice Gates”
 - 5,000 cycles with confirmation of specified torque and position repeatability

11.5 Diagnostic features

The diagnostics menu provides live statistics on the actuator's status and performance. Actuator alarms and warnings can be viewed in real time for up-to-date status. Historic and live profiles, histograms, trends and time-stamped data logs give greater insight into the process while configurable maximum sensor readings and deviations allow for greater control and flexibility with preventive maintenance. Anything and everything an end user needs to know is available in our new advanced diagnostics options.

11.6 Factory test

Factory testing verifies rated output torque, output speed, motor performance, handwheel operation, local control, control power supply, control features and baseline functionality. A report confirming successful completion of testing is included within the actuator.

11.7 Conduit entries

Three threaded conduit entries are provided for the MX actuator; tapped: 1 x 1½ in and 2 x 1¼ in NPT. The actuator is available with 1 x M40 and 2 x M25 metric to BS3643, and PG adapters are available upon request. Optional M25 or M32 adapters are available. An optional 1.0 in or M25 conduit opening is also available.

11.8 European Directives

All MX actuator designs have been tested to comply with pertinent EU Directives and shipped with the Declaration of Conformity listed in the Regulatory Section of VAIOM000071. The actuator is also tagged with the CE mark to demonstrate compatibility with the following European Directives:

Directives 2006/142/EC – Machinery, 2004/108/EC – EMC – Electromagnetic Compatibility, 73/23/EC and 93/68/EC – Low-Voltage, 2014/34/EU - ATEX Directive and 2003/10/EC Airborne Noise.

Vibration Levels (MX actuator functions after event)	Seismic Levels (MX actuator functions after event)
5 to 100 Hz sine sweeps, 0.75g 3 axes	2 Hz 2g, 2.5 to 35 Hz 3g, sine dwell, 3 axes
5 to 500 Hz sine sweeps, 1.0g 3 axes	1 Hz 0.5g, 2 to 50 Hz 1g, sine sweeps, 3 axes
25 Hz 2g, 40 to 200 Hz 3g, sine dwells, 3 axes	

- Temperature extremes with humidity** – Confirm function of motor, controls and output torque at -30°C (-22°F) for 72 hours continuous, 65°C (149°F) dry heat for 16 hours continuous, and 65°C (149°F) damp heat for 72 hours continuous. The actuators have also been subjected to arctic extremes down to -60°C (76°F) and maximum temperatures to 40°C (104°F). The maximum temperature is limited by the lubrication viscosity.
- Di-electric** – Motor per NEMA MG1-12.02 and 0.03 with leakage of less than 10 mA. Control terminals per IEC-1131-2 with check against physical breakdown.

Table 11: EMC test criteria

Applicable emissions standards	EN61326-1 (CISPR11)	Industrial Environments - Class A - Test Limits and Levels	
Radiated Emissions	EN55011: 2009+A1: 2010 (CISPR11)	30 to 230 MHz	40 dB (µV/m)
		230 MHz to 1 GHz	47 dB (µV/m)
	FCC Part 15, (CFR47 Part 15.109)	30 to 88 MHz	90 dB (µV/m)
		88 to 216 MHz	150 dB (µV/m)
		216 to 960 MHz	210 dB (µV/m)
		> 960 MHz	300 dB (µV/m)

Applicable emissions standards	EN61326-1 (CISPR11)	Industrial Environments - Class A - Test Limits and Levels	
Conducted Emissions	EN55011:2009+A1: 2010 (CISPR11)	150 to 500 kHz	79 dB (µV) (quasi-pk), 66 dB (µV) (avg)
	FCC Part 15, (CFR47 Part 15.107)	500 kHz to 30 MHz	73 dB (µV) (quasi-pk), 60 dB (µV) (avg)
Applicable emissions standards	EN61326-1 (Performance Criterion)	Industrial Environments - Test Limits and Levels	
Electrostatic Discharge	EN61000-4-2 (B)	Contact	±1 kV, ±2 kV, ±4 kV
		Air	±2 kV, ±4 kV, ±6kV, ±8 kV
Radiated RF Susceptibility	EN61000-4-3 (A)	Enclosure @ 80 MHz to 1 GHz	10 Vrms/m @ 80% AM, 1 kHz
		Radiated RF Susceptibility	3 Vrms/m @ 80% AM, 1 kHz
		Enclosure @ 2 to 2.7 GHz	1 Vrms/m @ 80% AM, 1 kHz
Electrical Fast Transient/ Burst	EN61000-4-4 (B)	AC power, DC power	±2 kV
		I/O (mains connected)	±2 kV
		I/O (non-mains)	±1 kV
Voltage Surge	EN61000-4-5 (B)	AC Power, DC Power	±1 kV (DM), ±2 kV (CM)
		I/O (mains connected)	±2 kV (CM)
		I/O (non-mains)	±1 kV (CM)
Conducted RF Immunity	EN61000-4-6 (A)	AC Power, DC Power, I/O @ 150 kHz to 80 MHz	3 Vrms @ 80% AM, 1 kHz
Magnetic Immunity	EN61000-4-8 (A)	Three mounting axes, X, Y, Z	30 A/m, 60 sec dwell
Voltage Dips and Interrupts	EN61000-4-11 (B)	3 dips, 10 sec apart	100% dip for 1 cycle @ 50/60 Hz
		3 dips, 10 sec apart	60% dip for 200 ms @ 50/60 Hz
		3 dips, 10 sec apart	30% dip for 500 ms @ 50/60 Hz
	EN61000-4-11 (C)	3 dips, 10 sec apart	100% interrupt for 5 sec @ 50/60 Hz

12. Wiring configurations

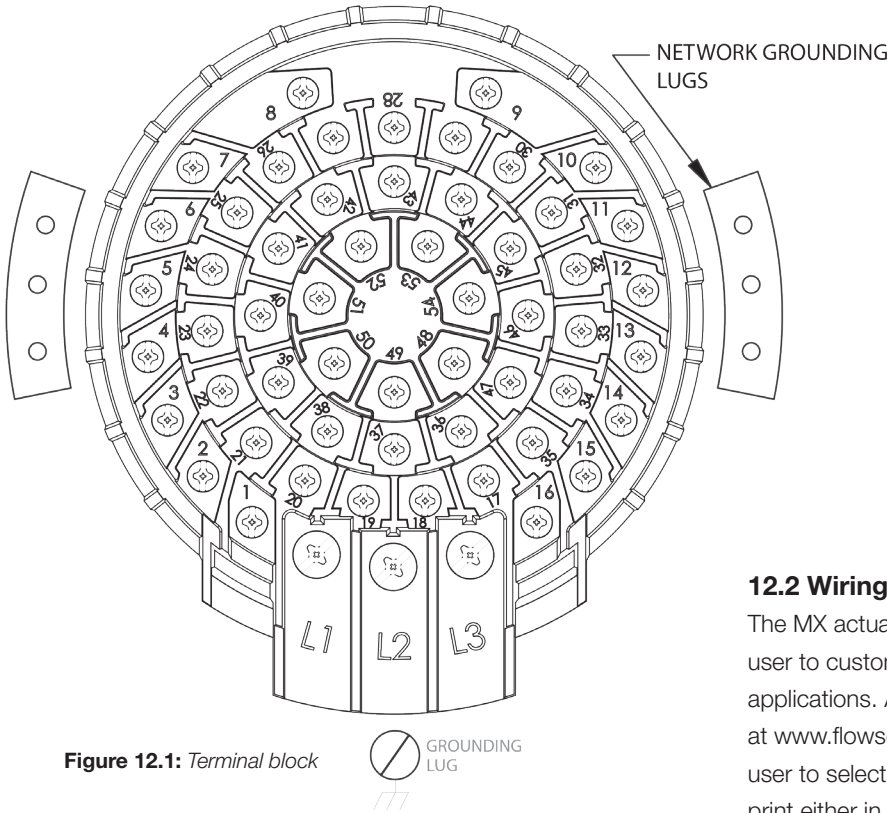

Figure 12.1: Terminal block



12.1 Terminal block

The standard terminal block for the MX actuator has 54 points and can sustain all of the options for the MX actuator.

Grounding (earth) lugs are provided for both power leads and network control. It is recommended that the machined areas adjacent to the terminal block be used to properly ground any network applications.

12.2 Wiring diagram configurator

The MX actuator features multiple options that permit a user to customize the electric actuator for very specific field applications. A wiring diagram configurator is available online at www.flowserve-wiring.com. This configurator permits a user to select the options for their specific application and print either in a Adobe Acrobat PDF version, or in an Autodesk DXF version.

The relay options are listed as follows:

- R4 = Standard S relays (4) and Monitor Relay (1) rated for 5A/30 VDC, 250 VAC. Total combined current through all four standard relays must not exceed 8A.
- R8 = Optional R Relays (4) rated for 5A/30 VDC, 250 VAC

13. Wiring diagrams

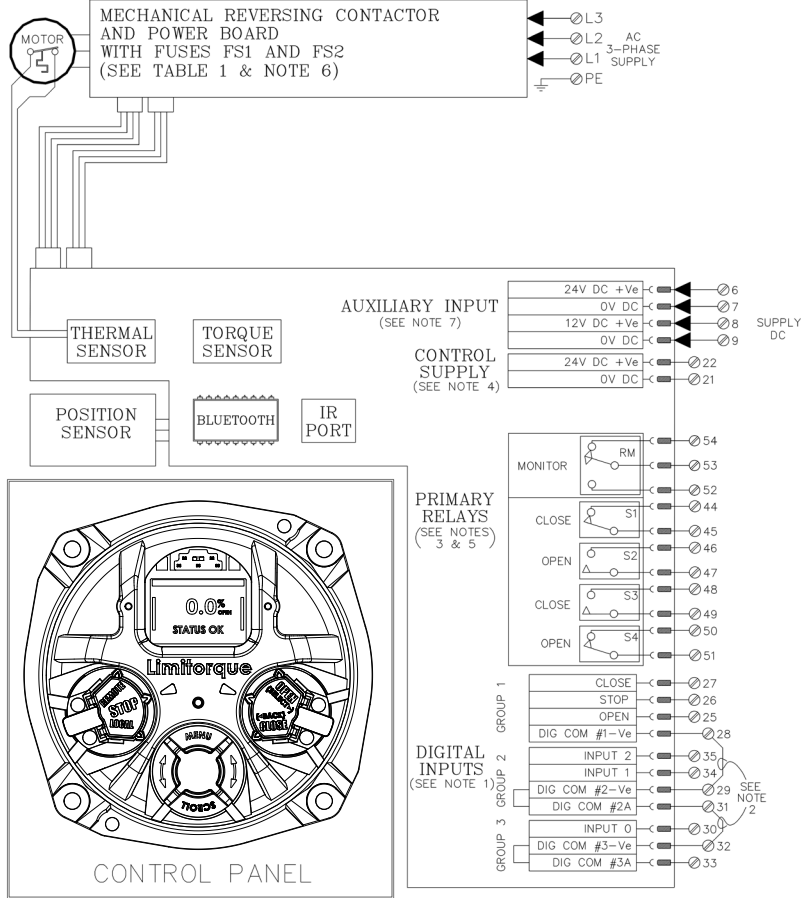

DIGITAL OUTPUTS
THE DIGITAL OUTPUTS (S) MAY BE INDIVIDUALLY CONFIGURED AS OPEN OR CLOSE LATCHED, OR AS BLINKER CONTACTS S1 to S4 MAY ALSO BE "DDC CONTROLLED" FROM MASTER STATION.

Transformer Tapping Options

TYPE	TAPS	APPL. VOLTAGES	TYPE	TAPS	APPL. VOLTAGES	TYPE	TAPS	APPL. VOLTAGES
1	106 V	110 V	2	226 V	226 V, 260 V, 240 V	3	212 V	220 V
	115 V	115 V, 120 V		366 V	380 V		505 V	525 V
	200 V	208 V	392 V	400 V, 415 V	550 V		550 V	
	220 V	220 V	450 V	440 V, 460 V, 480 V	572 V		575 V, 600 V	

NOTE: SEE INSTALLATION & OPERATION MANUAL FOR DETAILS – LMENIM2306 FOR THE MX

1. FUSES

- FS1 (PRIMARY) } 600 VAC, 1 A, 200 kA Int RATING, FAST ACTING 10.3 x 38.1 mm TUBE.
- FS2 (PRIMARY) }
- FS3 (SECONDARY) - 0.1 A, 250 V, TIME DELAY, 5 x 20 mm, GLASS TUBE

2. AUXILIARY INPUT (OPTIONAL W/ BACKUP POWER BOARD)

BACK-UP 24 VDC UPS POWER MAY BE CONNECTED TO TERMINALS 6 AND 7. MAXIMUM CURRENT DRAW IS 1 AMP. THIS POWERS ALL CONTROLS FOR LOCAL INDICATION AND CONFIGURATION, INCLUDING ANALOG OUT AND NETWORK COMMUNICATION. REVERSING CONTACTOR WILL NOT BE POWERED. CUSTOMER MUST SUPPLY EXTERNAL FUSE AS REQUIRED BY LOCAL ELECTRICAL CODES.

3. MAXIMUM EXTERNAL LOAD

TERMINALS 21 AND 22 (24 VDC) - 5 W MAX. EXT. LOAD
TERMINALS 23 AND 24 (OPT. 110 VAC) - 20 W MAX. EXT. LOAD, 15 VA

4. REMOTE INPUTS

SIGNAL THRESHOLD - MINIMUM "ON": 19.2 VAC/VDC
MAXIMUM "OFF": 5.0 VAC/VDC
MAX LOAD - 10 mA / 110 VAC
2 mA / 24 VDC
REQUIRED CONTROL SIGNAL DURATION = 350 ms MIN.

INPUTS 0, 1, 2 ARE FIELD CONFIGURABLE FOR CLOSE/OPEN INHIBIT, REDUNDANT OPEN, CLOSE, STOP (LIMIGARD) USER INPUT, OR ESD.

IN ADDITION:
INPUT 0 MAY BE CONFIGURED FOR CLOSE;
INPUT 1 MAY BE CONFIGURED FOR STOP;
INPUT 2 MAY BE CONFIGURED FOR CSE

REMOTE SELECTION INDICATION:
DEFAULT INPUT CONFIGURATION:
INPUT 0 - ESD,
INPUT 1 - OPEN INHIBIT,
INPUT 2 - CLOSE INHIBIT

5. REMOTE INPUT JUMPERS

JUMPERS ARE USER WIRED TO CONNECT DIG COMMONS #1, 2 & 3 (AS NEEDED).

6. STATUS FEEDBACK OUTPUT SWITCHES

THE ACTUATOR STATUS CONTACTS (S1 & S2) MAY BE INDIVIDUALLY CONFIGURED AS NORMALLY OPEN OR NORMALLY CLOSED LATCHED CONTACTS, OR AS BLINKER CONTACTS, PLEASE REFER TO SECTION 5.1 FOR STATUS FUNCTION CHOICES.

7. CONTACT RATINGS

- S1, S2 - 0.5 A @ 125 VAC, 2 A @ 30 VDC (RESISTIVE)
- MONITOR - 0.5 A @ 125 VAC, 2 A @ 30 VDC (RESISTIVE)

8. DEFAULT [S] SETTING

THE DEFAULT OPERATING CONFIGURATION FOR THE "S" OUTPUTS ARE SHOWN IN THE TABLE BELOW. THE CONTACT STATES SHOWN IN THE SCHEMATIC REPRESENT A FULLY CLOSED VALVE.

OUTPUT SWITCH	VALVE POSITION		FUNCTION
	FULL CLOSE	FULL OPEN	
S1a	—	—	CLOSE LIMIT
S1b	—	—	
S2a	—	—	OPEN LIMIT
S2b	—	—	

LEGEND
— — OPEN CONTACT
— — CLOSED CONTACT

S1a & S1b HAVE COMPLEMENTARY LOGIC
S2a & S2b HAVE COMPLEMENTARY LOGIC

Figure 13.1: Standard wiring diagram (standard three-phase ACV shown; consult factory for other voltage wiring diagrams)

Circuit shown with valve in fully closed position and power off.

OPTIONAL ALARM RELAYS

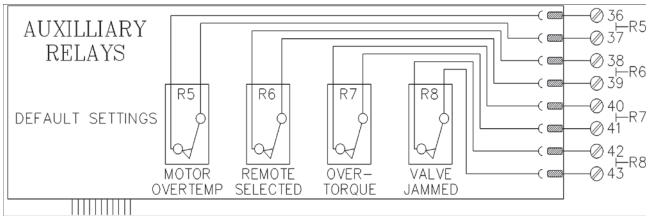

ALARM FEEDBACK

THE ALARM CONTACTS (R) MAY BE CONFIGURED FOR ANY FUNCTION SHOWN IN SECTION 6.1, AND MAY BE INDIVIDUALLY CONFIGURED AS NORMALLY OPEN, NORMALLY CLOSED OR BLINKER LATCHED CONTACTS.

CONTACT RATINGS

S1, 2, 3, 4 and R5, 6, 7, 8 - 5.0 A at 250 VAC, 30 VDC

NOTE: Combined current through S1 to 4 must not exceed 8A.

MODUTRONIC

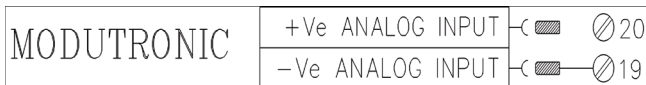

MODUTRONIC

STANDARD SIGNAL 4-20 mA
 INPUT IMPEDANCE = 350 ohms
 INPUT CAPACITANCE = 0.1 MF 30%
 99% ACCURACY
 CONFIGURABLE SCALING

ANALOG POSITION OR TORQUE TRANSMITTER

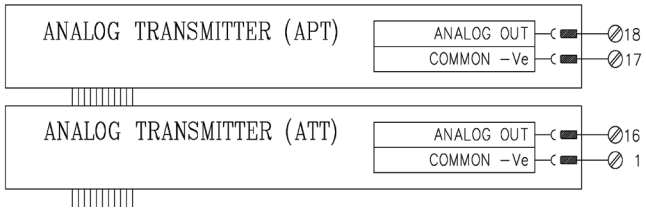

EXTERNAL LOAD – APT & ATT

4-20 MA SIGNAL - 470 OHMS MAXIMUM FOR 99.9% ACCURACY/750 OHMS MAXIMUM FOR 99% ACCURACY
 0-10 VDC SIGNAL - 2,700 OHMS MINIMUM FOR 99% ACCURACY AND 1,000 OHMS FOR 99.9% ACCURACY.

Optional voltages or currents; 0-20 mA,
 0-10 VDC, 2-10 VDC, 0-5 VDC, 1-5 VDC

EXACT END POSITION INDICATION

ON TORQUE-SEATED VALVES, THE LCD AND “S” CONTACTS CONFIGURED AS END-OF-TRAVEL LIMITS AUTOMATICALLY PROVIDE EXACT END POSITION INDICATION.



Maximum external load - 110 VAC out 15W max. ext load

Figure 13.2: Optional features, wiring diagrams

Limitorque® MX Series B Smart Electric Actuator

DDC – Modbus

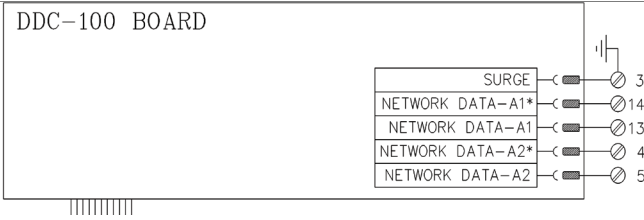

LOSS OF COMMUNICATION ON A1 => REGISTER 9 CHANNEL A (BIT 0x0400) SET TO 1

LOSS OF COMMUNICATION ON A2 => REGISTER 9 CHANNEL B (BIT 0x0800) SET TO 1

PREFERRED NETWORK WIRING IS TO CONNECT ONLY ONE SHIELD TO EARTH/GROUND. REFER TO DDC INSTALLATION DOCUMENTATION.

Foundation Fieldbus H1

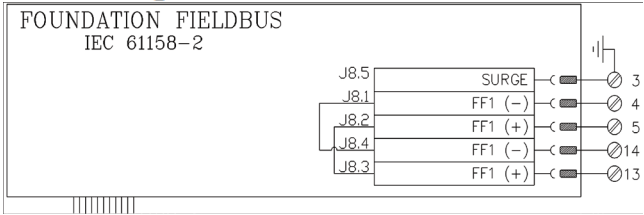

CUSTOMER IS REQUIRED TO CONNECT WIRE BETWEEN TERMINAL 3 AND CHASSIS GROUND FOR SURGE PROTECTION. PREFERRED NETWORK WIRING IS TO CONNECT SEGMENT SHIELD TO EARTH/GROUND AT ONE POINT ONLY. ATTACH SHIELD TO TERMINAL 3 ONLY IF SEGMENT IS NOT GROUNDED. ELSEWHERE, CUSTOMER MUST CONNECT INDIVIDUAL NETWORK CABLE SHIELDS TOGETHER TO ENSURE PROPER SHIELDING OF THE ENTIRE NETWORK. CURRENT DRAW FOR FF BOARD 24 mA MAXIMUM.

DeviceNet

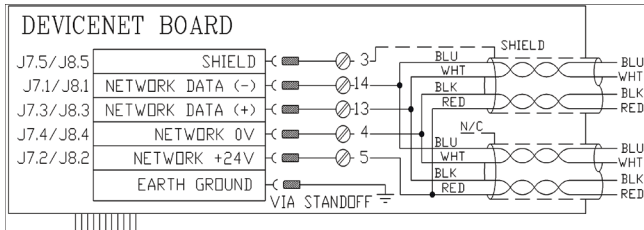

RECOMMENDED DEVICENET CABLE IS BELDEN 3084A OR EQUAL. 120 OHM, 1/4W TERMINATION RESISTORS MUST BE CONNECTED AT EACH SEGMENT END. PREFERRED NETWORK WIRING IS TO CONNECT SHIELD TO TERMINAL 3 FOR EVERY UNIT ON SEGMENT. SHIELD SHOULD BE CONNECTED TO POWER SUPPLY GROUND AT THE CLOSEST POINT IN THE CENTER OF THE NETWORK.

HART



NOMINAL ANALOG INPUT CURRENT 4-20mA, 30mA MAX. ANALOG INPUT SIGNAL LOAD-300 OHMS. SET JUMPERS JP1 AND JP2 TO POSITION 1-2. THE 3-PIN CONNECTOR WITH BLUE WIRES SHOULD BE CONNECTED TO J3 ON HART BOARD. (J1 IS NOT USED) HART TERMINAL CONNECTIONS: TERMINAL 12 ----- LOOP(+) TERMINAL 17 ----- LOOP(-)

Profibus DP_V1

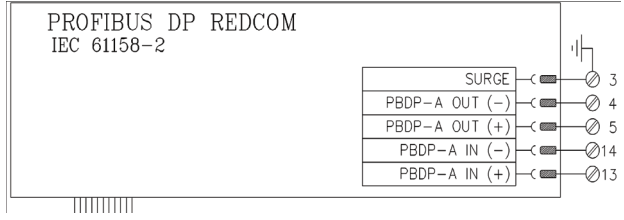

CUSTOMER IS REQUIRED TO CONNECT WIRE BETWEEN TERMINAL 3 AND CHASSIS GROUND FOR SURGE PROTECTION. PREFERRED NETWORK WIRING IS TO CONNECT SHIELD TO EARTH/GROUND AT BOTH ENDS OF THE SEGMENT. ATTACH SHIELD TO TERMINAL 3 ONLY IF DEVICE IS LOCATED AT THE ENDS OF THE SEGMENT. CUSTOMER MUST CONNECT REMAINING INDIVIDUAL NETWORK CABLE SHIELDS TOGETHER TO ENSURE PROPER SHIELDING OF THE ENTIRE NETWORK.

Redundant Profibus DP_V1

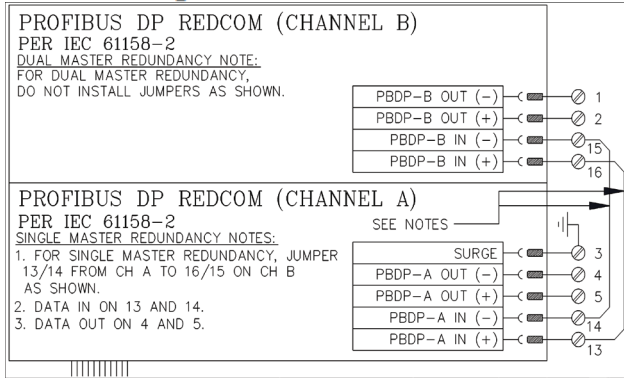

CUSTOMER IS REQUIRED TO CONNECT WIRE BETWEEN TERMINAL 3 AND CHASSIS GROUND FOR SURGE PROTECTION. PREFERRED NETWORK WIRING IS TO CONNECT SHIELD TO EARTH/GROUND AT BOTH ENDS OF THE SEGMENT. ATTACH SHIELD TO TERMINAL 3 ONLY IF DEVICE IS LOCATED AT THE ENDS OF THE SEGMENT. CUSTOMER MUST CONNECT REMAINING INDIVIDUAL NETWORK CABLE SHIELDS TOGETHER TO ENSURE PROPER SHIELDING OF THE ENTIRE NETWORK.

Profibus PA

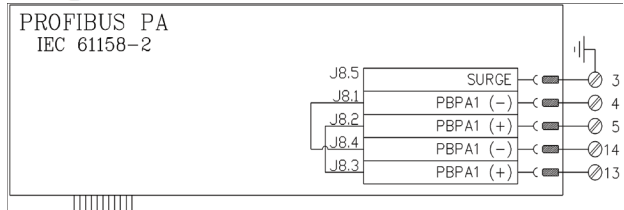

CUSTOMER IS REQUIRED TO CONNECT WIRE BETWEEN TERMINAL 3 AND CHASSIS GROUND FOR SURGE PROTECTION. PREFERRED NETWORK WIRING IS TO CONNECT SEGMENT SHIELD TO EARTH/GROUND AT ONE POINT ONLY. ATTACH SHIELD TO TERMINAL 3 ONLY IF SEGMENT IS NOT GROUNDED. ELSEWHERE, CUSTOMER MUST CONNECT INDIVIDUAL NETWORK CABLE SHIELDS TOGETHER TO ENSURE PROPER SHIELDING OF THE ENTIRE NETWORK.

NOTES:

TERMINALS 13 & 14 FOR FOUNDATION FIELDBUS, PROFIBUS PA, PROFIBUS DP_V1 ARE USED FOR CHANNEL B ON OPTIONAL REDUNDANT NETWORK BOARD.

Figure 13.3: DDC, Foundation Fieldbus, Profibus DP_V1, Redundant Profibus DP_V1, and Profibus PA, HART and DeviceNet network wiring diagrams

REMOTE WIRING CONNECTIONS

	(-) NEGATIVE COMMON				(+) POS. COMMON
	3-WIRE Configurable SET-UP to give; Either -OPEN/CLOSE push-to-run (inching) mode OR -OPEN/CLOSE push and release (maintained) mode with mid- travel reversal (Stop before reverse)	4-WIRE OPEN/STOP/CLOSE Push-and-release (maintained) MODE with mid-travel reversal and mid-travel stop	INHIBIT Configurable during SET-UP to give; interlock/inhibit on maintained open or close contacts SEE NOTE 4	ESD Configurable during SET-UP to give following modes of ACTIONS on receipt of a maintained ESD signal: CLOSED/OPEN/STOP/IGNORED SEE NOTE 4	Remote inputs configured as positive common [Open,Stop,Close Only] SEE NOTE 4
EXTERNAL SUPPLY 24 TO 110 VAC/VDC					
INTERNAL SUPPLY 110 VAC (OPTIONAL)					
INTERNAL SUPPLY 24 VDC					
TERMINAL POINT FUNCTION	CLOSE (27) STOP (26) OPEN (25) DIG COM #1 (28)	0 VAC (23) 110 VAC (24) +24 VDC (22) 0 VDC (21)	OPEN INHIBIT (34) CLOSE INHIBIT (35) ESD (30) EXTERNAL SUPPLY ↓	DIG COM #2(A) (29, 31) DIG COM #3(A) (32, 33)	LIMIGARD CONFIG WIRING

- NOTES:
- THE 3 REMOTE WIRING GROUPS ARE ELECTRICALLY ISOLATED INTERNALLY. SINGLE OR MULTIPLE POWER SOURCES MAY BE SELECTED TO INDIVIDUALLY POWER EACH GROUP. IF MULTIPLE SOURCES ARE USED, ENSURE THAT POLARITIES ARE CORRECT.
 - ONLY A SINGLE POWER SOURCE MAY POWER ANY ONE GROUP.
 - COMMONS MAY BE CONNECTED TOGETHER AS NEEDED.
 - REMOTE INPUTS SIGNAL THRESHOLD
MINIMUM "ON" 19.2 VAC/DC
MAXIMUM "OFF" 5.0 VAC/DC
MAX LOAD - 10 mA / 110 VAC/Vdc
2 mA / 24 Vdc
 - COMMAND PRIORITY
MODUTRONIC COMMAND WILL OVERRIDE 3 AND 4 WIRE COMMANDS.
INHIBIT AND ESD SIGNALS WILL OVERRIDE MODUTRONIC COMMANDS.

Figure 13.5: Remote wiring connections

14. Network protocol connections

14.1 Network wiring – DDC-Modbus

Please consult LMENIM2329 for detailed installation instructions.

Belden 3105A specifications

Total cable length between repeaters or nodes with repeaters:

- @ 9.6 kbps: 3.5 km (11,500 ft)
- @ 19.2 kbps: 1.7 km (5,750 ft)

Key specifications

- Resistance/304.8 m (1,000 ft) = 22 AWG (7 x 30) 14.7 ohms each conductor (29.4 ohms for the pair)
- Capacitance/ft = 11.0 pF (conductor-to-conductor)
- Capacitance/ft = 20.0 pF (conductor-to-shield)

Belden 3074F specifications

Total cable length between repeaters or nodes with repeaters:

- @ 9.6 kbps: 4.5 km (15,000 ft)
- @ 19.2 kbps: 2.2 km (7,500 ft)

Key specifications

- Resistance/304.8 m (1,000 ft) = 18 AWG (7x26) 6.92 ohms each conductor (13.84 ohms for the pair)
- Capacitance/ft = 14 pF (conductor-to-conductor)
- Capacitance/ft = 14 pF (conductor-to-shield)

Belden 9841 specifications

Total cable length between repeaters or nodes with repeaters:

- @ 9.6 kbps: 2 km (6,560 ft)
- @ 19.2 kbps: 1 km (3,300 ft)

Key specifications

- Resistance/304.8 m (1,000 ft) = 24 AWG (7 x 32) 24 ohms each conductor (48 ohms for the pair)
- Capacitance/ft = 12.8 pF (conductor-to-conductor)
- Capacitance/ft = 23 pF (conductor-to-shield)

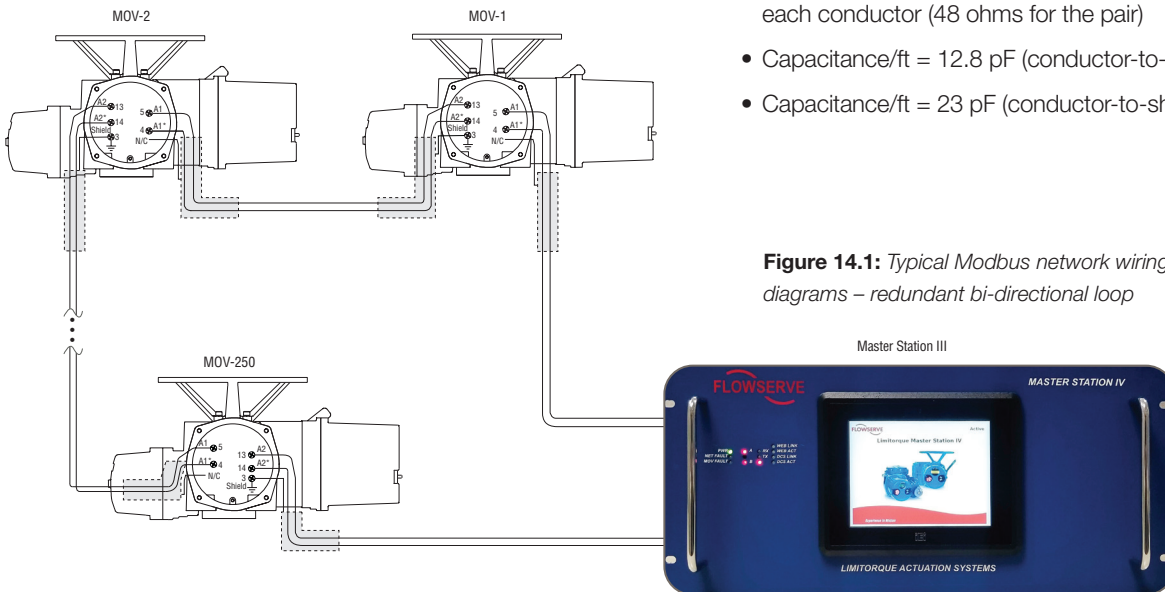

Figure 14.1: Typical Modbus network wiring diagrams – redundant bi-directional loop

Legend:

- MOV - Motor Operated Valve
- A1 - Data Channel 1
- A1* - Data Channel 1*
- A2 - Data Channel 2
- A2* - Data Channel 2*
- N/C - No Connection
- [Dashed Box] - Shielded cable

Notes:

- Correct polarity for field unit and master station connections is necessary for proper operation.
- The connections shown are typical. The number of MOVs will vary, up to a maximum of 250.
- The ground connection should be a ground rod or ground grid.
- Ensure the network is grounded to the machined ground network lug areas, shown in Figure 12.1

14.2 Network wiring — Foundation Fieldbus H1

Please refer to LMENIM2330 for detailed installation instructions.

Limitorque’s Foundation Fieldbus field unit conforms to open Fieldbus standard IEC 61158. It is suitable for use on the H1 highway and uses a twisted-pair cable for connection to the highway.

The MX actuator’s FF field unit fits in the actuator in the sealed electrical housing. All adjustments to the FF settings may be made over the Foundation Fieldbus data highway using a network configuration tool.

The MX actuator’s FF unit may command its actuator to open, stop, close, move to a set position, or perform an emergency shutdown operation. Commands to the unit come over the network from the host system, which may be a PC, distributed control system (DCS), programmable logic controller (PLC), or some other microprocessor-based device. Commands may also be generated in another network actuator or device and transmitted over the fieldbus using the publisher/subscriber communication method.

A fieldbus device is an intelligent device within the actuator that can send multiple variables to the control system over a high-resolution and distortion-free digital communication network. The device provides control and self-test capabilities, which allow abnormal conditions to be easily and immediately identified before an unplanned shutdown.

Additional features and benefits are:

- Reduces cost of wiring and installation – existing wiring and multi-drop connections can be used.
- Interoperable devices – devices from different suppliers can communicate with one another on the same network.

A typical MX actuator FF network is shown in Figure 14.2.

For fieldbus technology and cabling information, refer to the following documents:

- Foundation Fieldbus Wiring and Installation 31.25 k bits/s, Voltage Mode, Wire Medium AG-140
- Foundation Fieldbus Technical Overview, FD-043
- Relcom Inc. Fieldbus Wiring Design and Installation Guide
- ANSI/ISA-S50.02, Part 2-1992, Fieldbus Standard for Use in Industrial Control Systems Part 2: Physical Layer Specification and Service Definition
- Foundation Fieldbus FF-890 and FF-891, Foundation Specification, Function Block Application Process, Parts 1 and 2

Reference can be made to the following books:

- Fieldbuses for Process Control: Engineering, Operation, and Maintenance. ISBN 1-55617- 760-7

Network wiring – Foundation Fieldbus

Belden 3076F specifications

Key Specifications – 18 AWG

- Nominal capacitance: 80 pF/m
- Nominal DC resistance: 24 ohm/km max
- Characteristic impedance: 100 ohms
- Nominal impedance: 100.0

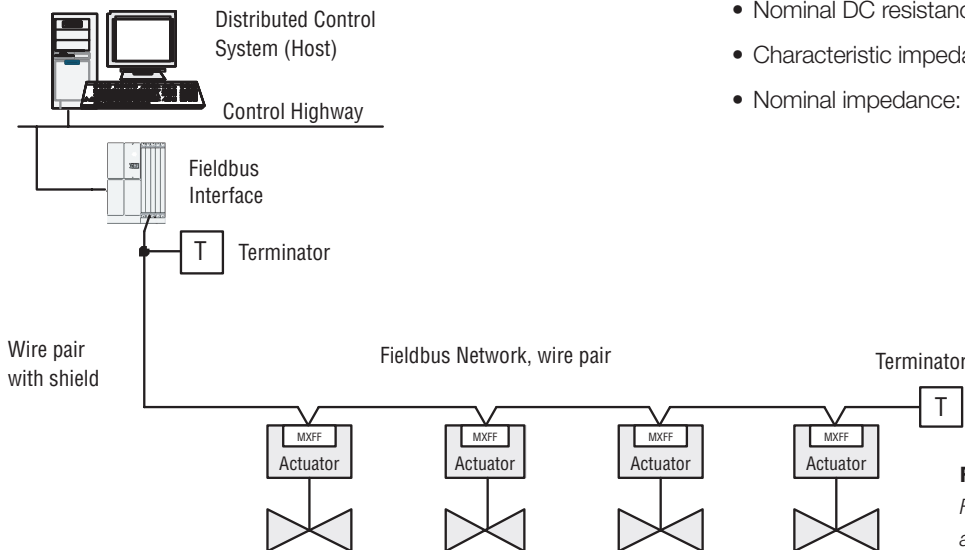

Figure 14.2: Typical Foundation Fieldbus network with DCS or PLC as the host system

14.3 Network wiring – Profibus DP and PA

Please refer to LMENIM2336 for detailed installation instructions for Profibus PA. Please refer to LMENIM2239 for Profibus DP with Redcom.

Profibus DP is based on RS 485 physical layer communications at transmission rates of 9.6 Kbps to 1.5 Mbps. Profibus PA is based on IEC1158-2 physical layer communications at a transmission rate of 31.25 Kbps. The standard EN 50170 specifies the cable for use with Profibus DP and PA. Table 14.1 shows specifications that need to be fulfilled by the Profibus DP cable, while Table 14.2 shows the specifications for Profibus PA cable.

Table 14.1: Specifications for the Profibus DP cable

Parameter	Type – Profibus DP
Impedance	135 to 165 ohm ³ to 20 MHz
Capacity	< 30 pF/m
Resistance	< 110 ohm/km
Wire gauge	> 0.64 mm
Conductor area	> 0.34 mm ²

Table 14.2: Specifications for the Profibus PA cable

Parameter	Type – Profibus DP
Characteristic impedance	100 ohms ± 20%
Maximum capacitance	2 nF/km
Loop resistance	44 ohms/km
Conductor cross-sectional area	0.8 mm ² (AWG 18)
Maximum length of network (including spurs)	1,900 m

For Profibus DP and PA, Limitorque recommends the use of:

- Belden 3079A and 3076F specifications for shielded, solid two-conductor wire

Figure 14.3a: PROFIBUS distance vs. baud rate chart

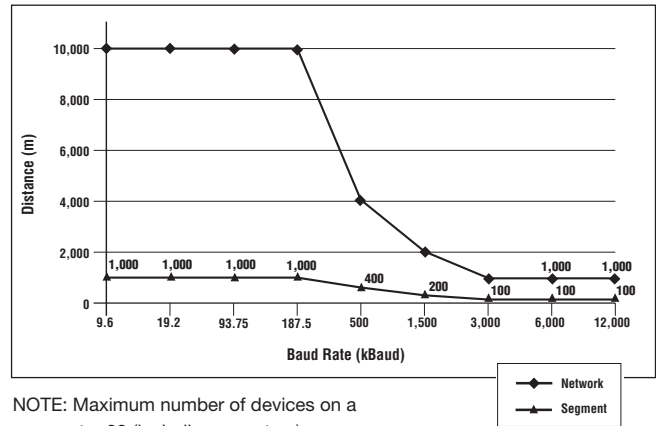

NOTE: Maximum number of devices on a segment = 32 (including repeaters)

Figure 14.3b: Typical PROFIBUS DP network (daisy chain shown)

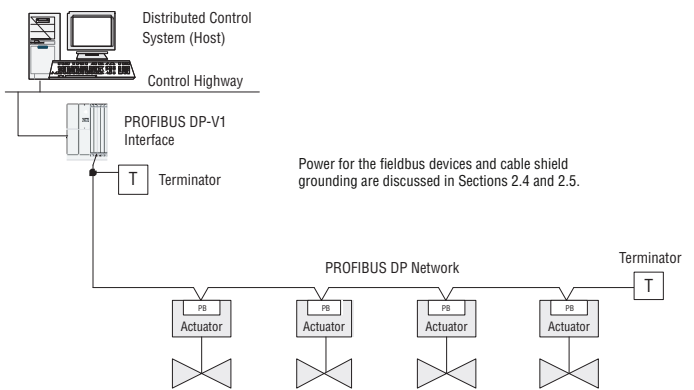
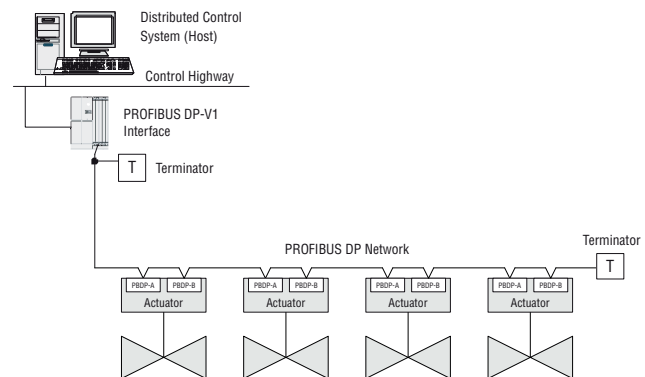

Figure 14.3c: Typical PROFIBUS DP network with redundancy option (single master)



Limatorque® MX Series B Smart Electric Actuator

Figure 14.5d: Typical PROFIBUS DP network with redundancy option (dual master)

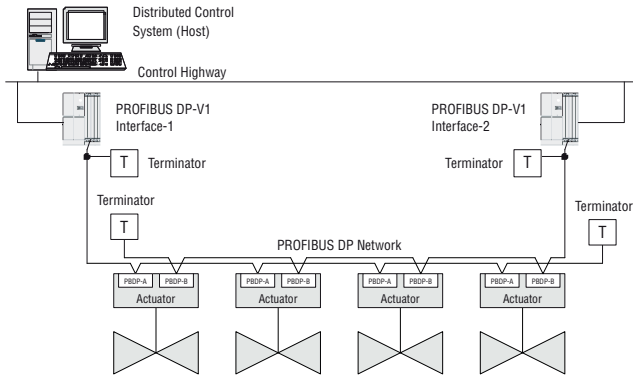
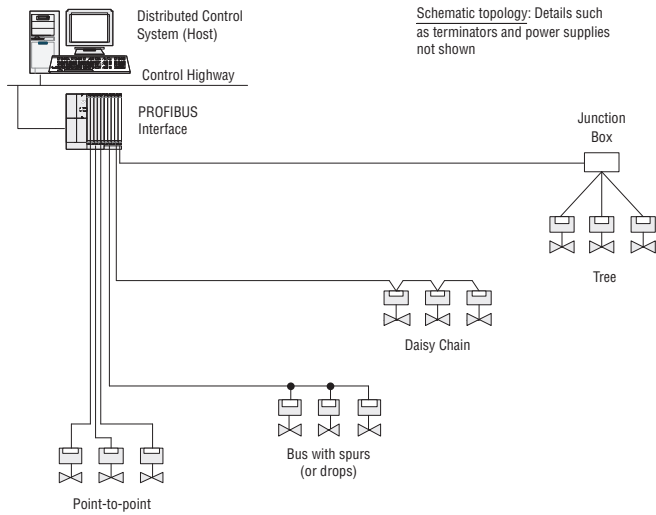

Figure 14.5e: Typical PROFIBUS PA network



14.4 Network wiring – DeviceNet

Please refer to LMENIM2328 for detailed installation instructions.

DeviceNet is a CAN-based protocol that uses five wires, including a shield. Two of the conductors are used for 24V DC power, and up to 8 amps (4 amps for NEC Class 2) may be passed along the highway from a suitable power source. Two conductors are used for the CAN bus signals, CAN_H and CAN_L, which are usually smaller in diameter. Limitorque recommends Belden cable for connecting to a DeviceNet network. The specifications for thick and thin cable (per site requirements) are as follows:

Table 14.5: Typical DeviceNet network

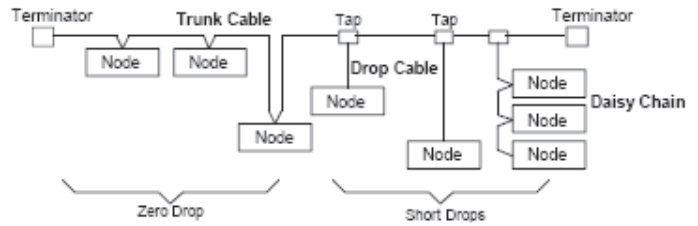

Table 14.3: Belden cable specifications

Belden Part No.	AWG (Stranding) Dia. in Nom. DCR	Insulation Material (Color Code)	Nominal O.D.	Nom Impedance (ohms)	Nominal Capacitance	Test Frequency (MHz)	Maximum Attenuation dB/100 ft
3082A	2 to 15 AWG (19 x 28) 3.6 ohm/1,000 ft 11.8 ohm/km	Power pair (Black/Red)	12.2 mm	120	12.0 pF/ft	0.125 0.5 1	0.13 0.25 1.36
	2 to 18 AWG (19 x 30) 6.9 ohm/1,000 ft 22.7 ohm/km	Data pair (Blue/White)					
3084A	2 to 22 AWG (19 x 34) 17.5 ohm/1,000 ft 57.4 ohm/km	Power pair (Black/Red)	7.2 mm	120	12.0 pF/ft	0.125 0.5 1	0.29 0.50 1.70
	2 to 18 AWG (19 x 36) 28.0 ohm/1,000 ft 91.9 ohm/km	Data pair (Blue/White)					

Table 14.4: Total cable length between repeaters or nodes

Network Size	125 KBPS	250 KBPS	500 KBPS
Thick Trunk Length	500 m (1,640 ft)	250 m (1,640 ft)	100 m (1,640 ft)
Thin Trunk Length	100 m (328 ft)	100 m (328 ft)	100 m (328 ft)
Flat Trunk Length	380 m (1,250 ft)	200 m (656 ft)	75 m (246 ft)
Maximum Drop Length	6 m (20 ft)	6 m (20 ft)	6 m (20 ft)
Cumulative Drop Length	156 m (512 ft)	78 m (256 ft)	39 m (128 ft)

Note: Each actuator includes 0.60 m (1.97 ft) of internal drop length.

14.5 Network wiring – HART

Please refer to LMENIM2340 for detailed installation instructions.

Network cabling should be in accordance with the HART Communication Foundation guidelines. In general, wiring for HART devices is the same as for conventional 4 to 20 mA instrumentation. It is recommended to use individually shielded twisted pair cable. The minimum conductor size is 0.51 mm (0.02 in) diameter (#24 AWG) for cable runs less than 1,500 m (5,000 ft), and 0.81 mm (0.031 in) diameter (#20 AWG) for distances up to the 3,000 m (10,000 ft) theoretical limit for HART communication. Please note that the electrical characteristics of the cable, especially capacitance, and the number of network field devices can affect the maximum allowable cable length. To prevent signal loop interference, tie all cable shields together and ground at only one point.

A typical MX HART system is shown below.

Figure 14.4: Typical HART system with a DCS host

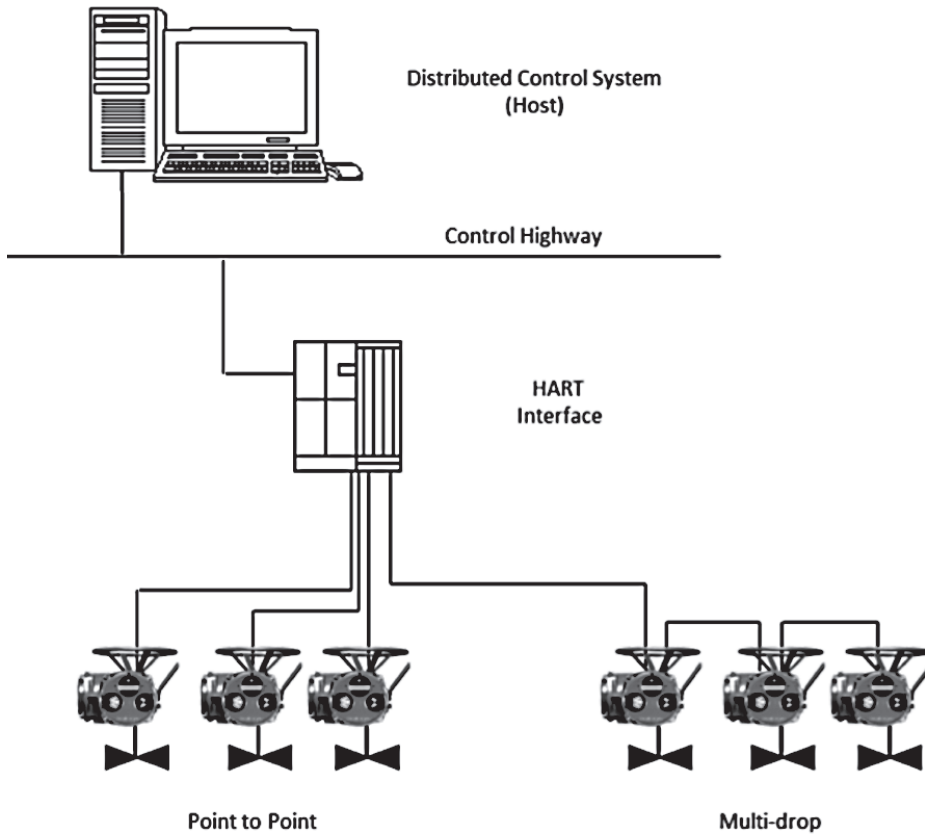



Flowserve Corporation
5215 North O'Connor Blvd.
Suite 2300
Irving, Texas 75039-5421 USA
Telephone: +1 937 890 5839

AITB000090-01 (EN/AQ) September 2020

Flowserve Corporation has established industry leadership in the design and manufacture of its products. When properly selected, this Flowserve product is designed to perform its intended function safely during its useful life. However, the purchaser or user of Flowserve products should be aware that Flowserve products might be used in numerous applications under a wide variety of industrial service conditions. Although Flowserve can provide general guidelines, it cannot provide specific data and warnings for all possible applications. The purchaser/user must therefore assume the ultimate responsibility for the proper sizing and selection, installation, operation, and maintenance of Flowserve products. The purchaser/user should read and understand the Installation Instructions included with the product, and train its employees and contractors in the safe use of Flowserve products in connection with the specific application.

While the information and specifications contained in this literature are believed to be accurate, they are supplied for informative purposes only and should not be considered certified or as a guarantee of satisfactory results by reliance thereon. Nothing contained herein is to be construed as a warranty or guarantee, express or implied, regarding any matter with respect to this product. Because Flowserve is continually improving and upgrading its product design, the specifications, dimensions and information contained herein are subject to change without notice. Should any question arise concerning these provisions, the purchaser/user should contact Flowserve Corporation at any one of its worldwide operations or offices.

©2020 Flowserve Corporation. All rights reserved. This document contains registered and unregistered trademarks of Flowserve Corporation. Other company, product, or service names may be trademarks or service marks of their respective companies.