

# Installation, Operation, Maintenance Instructions

## High Pressure Valves Series 011000 Angle Valve PN 1000 - 4000

Index	
1	Using Kämmer valves and actuators correctly.
2	Unpacking
3	Installation
4	Quick check
5	Maintenance
6	Remove and install actuator
7	Disassemble and assemble valve
8	Trouble-shooting chart

### 1 USING KÄMMER VALVES AND ACTUATORS CORRECTLY

#### 1.1 General

The following instructions are designed to assist in unpacking, installing and performing maintenance as required on Kämmer products. Product users and maintenance personnel should thoroughly review this bulletin prior to installing, operating or performing any maintenance.



**DANGER:** *In most cases Kämmer valves and actuators are designed for specific applications (e.g. with regard to medium, pressure, temperature). For this reason they should not be used in other applications without first contacting the manufacturer.*

#### 1.2 Terms concerning safety

The safety terms **DANGER**, **WARNING**, **CAUTION** and **NOTE** are used in these instructions to highlight particular dangers and/or to provide additional information on aspects that may not be readily apparent.



**DANGER:** *indicates that death, severe personal injury and/or substantial property damage will occur if proper precautions are not taken.*



**WARNING:** *indicates that death, severe personal injury and/or substantial property damage can occur if proper precautions are not taken.*



**CAUTION:** *indicates that minor personal injury and/or property damage can occur if proper precautions are not taken.*



**NOTE:** *indicates and provides additional technical information, which may not be very obvious even to qualified personnel. Compliance with other, not particularly emphasised notes, with regard to transport, assembly, operation and maintenance and with regard to technical documentation (e.g. in the operating instruction, product documentation or on the product itself) is essential, in order to avoid faults, which in themselves might directly or indirectly cause severe personal injury or property damage.*

#### 1.3 Protective clothing

Kämmer products are often used in problematic applications (e.g. extremely high pressures, dangerous, toxic or corrosive mediums). In particular valves with bellows seals point to such applications. When performing service, inspection or repair operations always ensure, that the valve and actuator are depressurised and that the valve has been cleaned and is free from harmful substances. In such cases pay particular attention to personal protection (protective clothing, gloves, glasses etc.).

#### 1.4 Qualified personnel

Qualified personnel are people who, on account of their training, experience and instruction and their knowledge of relevant standards, specifications, accident prevention regulations and operating conditions, have been authorised by those responsible for the safety of the plant to perform the necessary work and who can recognise and avoid possible dangers.

#### 1.5 Installation



**DANGER:** *Before installation check the order-no, serial-no. and/or the tag-no. to ensure that the valve/actuator is correct for the intended application.*

Do not insulate extensions that are provided for hot or cold services.

Pipelines must be correctly aligned to ensure that the valve is not fitted under tension.

**1.6 Spare parts**

Use only Kämmer original spare parts. Kämmer cannot accept responsibility for any damages that occur from using spare parts or fastening materials from other manufactures. If Kämmer products (especially sealing materials) have been on store for longer periods check these for corrosion or deterioration before using these products. Fire protection for Kämmer products must be provided by the end user.

**1.7 Service / repair**

To avoid possible injury to personnel or damage to products, safety terms must be strictly adhered to. Modifying this product, substituting nonfactory parts, or using maintenance procedures other than outlined in this instruction could drastically affect performance and be hazardous to personnel and equipment, and may void existing warranties. Between actuator and valve there are moving parts. To avoid injury Flowserve provides pinch-point-protection in the form of cover plates, especially where side-mounted positioners are fitted. If these plates are removed for inspection, service or repair special attention is required. After completing work the cover plates must be refitted. Apart from the operating instructions and the obligatory accident prevention directives valid in the country of use, all recognised regulations for safety and good engineering practices must be followed.



**WARNING: Before products are returned to Kämmer for repair or service Kämmer must be provided with a certificate which confirms that the product has been decontaminated and is clean. Kämmer will not accept deliveries if a certificate has not been provided (a form can be obtained from Kämmer).**

**1.8 Storage**

In most cases Kämmer Products are manufactured from stainless steel. Products not manufactured from stainless steel are provided with an epoxy resin coating. This means that Kämmer products are well protected from corrosion. Nevertheless, Kämmer products must be stored adequately in a clean, dry environment. Plastic caps are fitted to protect the flange faces and to prevent the ingress of foreign materials. These caps should not be removed until the valve is actually mounted into the system.

**1.9 Valve and actuator variations**

These instructions cannot claim to cover all details of all possible product variations, nor in particular can they provide information for every possible example of installation, operation or maintenance. This means that the instructions normally include only the directions to be followed by qualified personal where the product is being used for is defined purpose. If there are any uncertainties in this respect particularly in the event of missing product-related information, clarification must be obtained via the appropriate FLOWSERVE sales office.

**2 UNPACKING**

2.1 Each delivery includes a packing slip. When unpacking, check all delivered valves and accessories using this packing slip.

2.2 Larger valves can be lifted using slings on the yoke rods or, if present, on the lugs provided for this purpose. If slings are used, attach them so that the outer tubing or attaching parts are not damaged.



**WARNING: If slings are used, be aware that the centre of gravity of the valve may be above the lifting point. In this case, secure or support the valve against rotating, to prevent damage or personnel injury.**

2.3 Report transport damage to the carrier immediately.

2.4 In case of discrepancies, contact your nearest FLOWSERVE sales office.

**3 INSTALLATION**

3.1 Clean tubing prior to installing.

3.2 If possible, install the valve in an upright position (actuator on top), to ease maintenance. An upright installation position is important with low-temperature applications, in order to keep the distance between the packing material and the medium as large as possible. The packing material then retains the ambient temperature as much as possible.



**NOTE: Do not insulate extension bonnets that are provided for hot or cold services**

3.3 Make sure that sufficient overhead clearance above the actuator is maintained, to allow for disassembly of plug from the valve body.

Actuator size	Clearance (mm)	Actuator size	Clearance (mm)
37/47	95	P2	140
38/48	140	P3	140
39/49	140	P4	140
39D/49D	140	P5	140

3.4 After installing, check direction of flow again. The direction of flow is shown by the arrow on the housing.

3.5 If the valve is to be welded into the line, make sure that the valve is shielded from excessive heat.

3.6 Connect supply pressure and signal lines. Control valves are supplied with a positioner. The end connections for supply pressure and signal are clearly marked. Series 4 actuators and positioners are suitable for max. 4.2 bar (60 psi) supply pressure. If the supply pressure exceeds the pressure specified on the

nameplate, a pressure reducing station is required. If instrument air is not available, install an oil separator/air filter in the air inlet line. All connections must be leak free.

**WARNING: Prevent other items of equipment from making mechanical contact with the actuator housing.**

## 4 QUICK CHECK

Before operating, check the valve as follows:

- 4.1 Open and close the valve, and observe the movement of the actuator stem. The movement must be smooth and linear.
- 4.2 Check for maximum stroke through change of signal (for pneumatic positioners, 0.2 - 1.0 bar or corresponding split-range values; for IP positioners, 4-20 or 0-20 mA).
- 4.3 Check all air connections for leaks.
- 4.4 Tighten packing nut with 25 Nm torque.



**NOTE: An excessively tightened gland nut can cause excessive packing wear and can hinder the free movement of the plug stem.**

- 4.5 Check fail-safe position. To do this, close supply pressure and observe whether the valve opens or closes as defined.
- 4.6 After use at fluctuating temperatures, re-tighten all bolt connections and check for leaks.
- 4.7 Check that lower body is torqued to 300 Nm.

## 5 MAINTENANCE

Check valves for correct functioning at regular intervals (at least once every 6 months) as follows. This check can be made when installed and in many cases without interrupting production. If internal defects are suspected, see section „Disassembly and Assembly of Valve“.

- 5.1 Examine gaskets for leaks and if necessary re-tighten bolts (see Fig. 1).
- 5.2 Check bellows gasket and test connection - if present - for external leaks.
- 5.3 Check valve for damage caused by corrosive residues or corrosive vapours.
- 5.4 Clean valve/actuator and repaint as necessary.



**Warning: To prevent a buildup of electrostatic charge clean the actuator/valve with a damp cloth only.**

- 5.5 Check gland nut for correct torque (see table 1).



**NOTE: An excessively tightened gland nut can cause excessive packing wear and can hinder the free movement of the plug stem.**

- 5.6 If possible, open and close valve and check for maximum stroke and smooth movement of the plug stem. Irregular movement of the plug stem may indicate internal defects.



**WARNING: Keep hands, hair, clothing, etc. away from all moving parts. Failure to do so can lead to serious injury.**

- 5.7 Check all accessories for firm seating.
- 5.8 If possible, close supply pressure and check the fail-safe position.
- 5.9 Check stem boot for wear.
- 5.10 Check actuator for leaks. To do this, spray housing, air connections and plug stem guide with leak spray and check for any bubble formation.
- 5.11 Clean plug stem.
- 5.12 Check air filter, if present, and if necessary replace insert.



**Note: For further information regarding service and maintenance please contact your nearest FLOWSERVE office.**



**DANGER: On actuators with aluminium cases the actuator springs must be renewed with original spare parts every 10 years or after 50.000 operating hours which ever occurs first.**

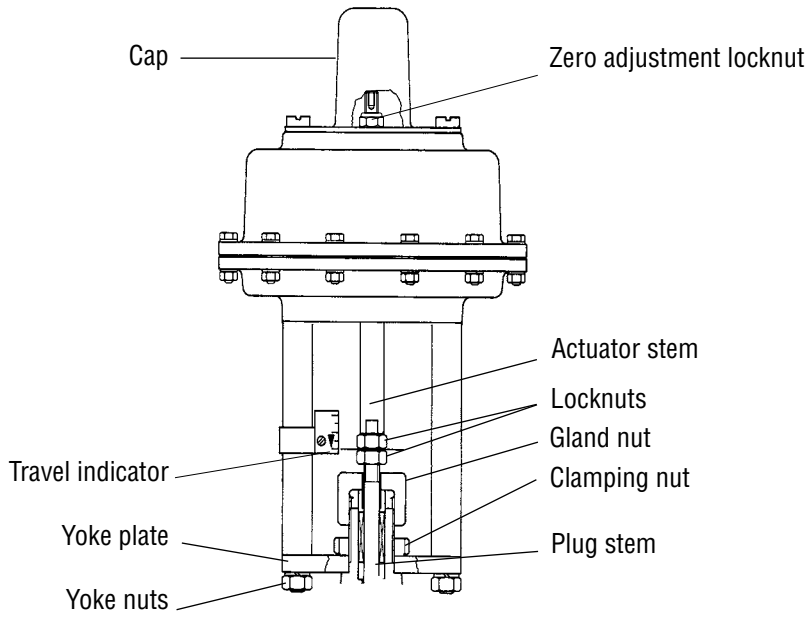

**Actuator series 4**  
**Fig. 1**

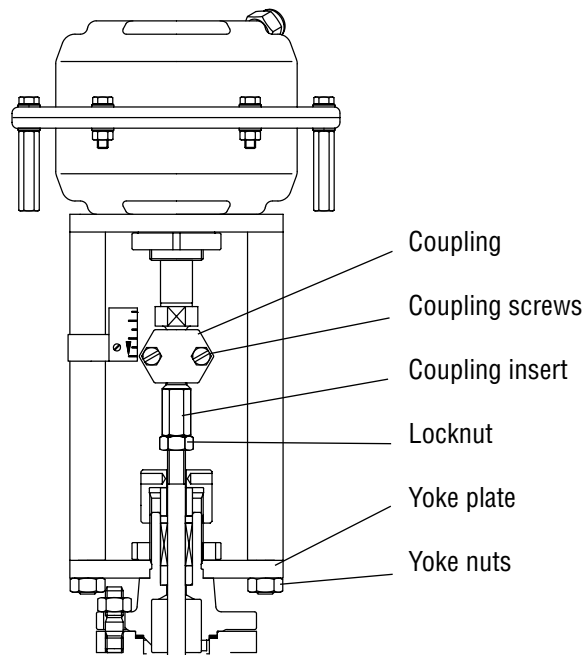

**Actuator series 2**  
**Fig. 1a**

## 6 REMOVE AND INSTALL ACTUATOR

### General Information

We recommend separating the actuator from the valve during all repair work. However, many maintenance and adjusting operations can be carried out in an installed condition.

### 6.1 Remove series 4 actuator

(see Fig 1 + 2)

For series 2 actuator see 6.3

For actuators with spring-to-close, go to 6.1.1

For actuators with spring-to-open, go to 6.1.2

#### 6.1.1 Shut off air supply.



**WARNING:** *Depressurise the line to atmospheric pressure and drain all fluids from the valve before working on the actuator. Failure to do so can cause serious injury.*

#### 6.1.2 Remove cap and nameplate. Tighten zero adjusting nut until it just touches the surface of the spring housing. This relieves the plug from actuator spring pressure. If the actuator is fitted with a handwheel this can be used to relieve the plug from actuator spring pressure.

#### 6.1.3 Using a wrench, secure the actuator stem against turning and using a second wrench loosen the stem locknuts. If the actuator is fitted with a coupling refer to the procedure described in the maintenance instructions for the I/P actuator.



**CAUTION:** *The actuator stem must not be rotated, as this will cause damage to the diaphragm.*

#### 6.1.4 Loosen gland and clamp nuts.

#### 6.1.5 Secure plug stem against turning and unscrew actuator from plug stem by rotating counter-clockwise.



**CAUTION:** *Ensure that the plug assembly is not rotated with the plug seated. This may cause irreparable damage to the seating faces.*

#### 6.1.5 Remove actuator and remove at the same time locknut, travel indicator disc, gland nut and clamp nut.

### 6.2 Install series 4 actuator

#### Information:

- Before the actuator is installed, it must be calibrated according to section 3 of the instructions „Pneumatic and Electro-pneumatic Actuators“.
- All worn or damaged parts must be replaced. Reusable parts must be clean.

#### 6.2.1 Position actuator with clamp nut, gland nut, locknuts and travel indicator disc on the valve.

#### 6.2.2 **Only for „spring-to-close“ actuators:**

Screw actuator onto plug stem by rotating clockwise, until the yoke plate just touches the valve housing and the actuator is aligned forward. If the actuator is fitted with a coupling refer to the procedure described in the maintenance instructions for the I/P actuator.



**CAUTION:** *Ensure that the plug assembly is not rotated with the plug seated. This may cause irreparable damage to the seating faces.*

#### **Only for „spring-to-open“ actuators:**

Lift plug stem and screw it into the lower coupling half until the distance between „plug in seat“ and „plug raised“ approximately corresponds to the specified stroke.

#### 6.2.3 Tighten clamp nut and gland nut.

#### 6.2.4 Adjust seat tightness by screwing/unscrewing the plug stem in/out of the actuator stem.



**CAUTION:** *Ensure that the plug assembly is not rotated with the plug seated. This may cause irreparable damage to the seating faces. Open valve, make adjustment, close valve and check for leaks. If the valve is fitted with a bellows seal the plug stem may NOT be rotated at all. In the case of a bellows seal adjustments are made with the coupling.*

#### 6.2.5 After adjusting, secure the locknuts and the travel indicator disc lying between them against actuator stem and align the travel indicator on the yoke rod.

### 6.3 Remove series 2 actuator

(see Fig. 1a)

For series 4 actuator see 6.1

#### 6.3.1 Shut off air supply.



**WARNING:** *Depressurise the line to atmospheric pressure and drain all fluids from the valve before working on the actuator. Failure to do so can cause serious injury.*

#### 6.3.2 Disconnect all tubing.

#### 6.3.3 Remove 2 screws and remove coupling.

#### 6.3.4 Remove yoke rod retaining nuts and lift actuator assembly from the valve.

#### 6.3.5 Remove coupling insert and it's locknut from plug stem.



**NOTE:** *Ensure that the plug assembly is not rotated with the plug seated. This may cause irreparable damage to the seating faces.*

### 6.4 Install series 2 actuator

(see Fig. 1a)

The actuator stem must be fully extended:

Actuators with air-to-open action must be fully vented. Actuators with air-to-close action apply supply pressure.

Manually depress the plug stem to ensure the plug is fully seated.

#### 6.4.1 Screw coupling insert locknut and coupling insert as far as possible onto plug stem.

#### 6.4.2 Place the actuator assembly on the valve engaging the yoke rod threads in the lower yoke plate and ensuring the actuator faces in the correct direction.

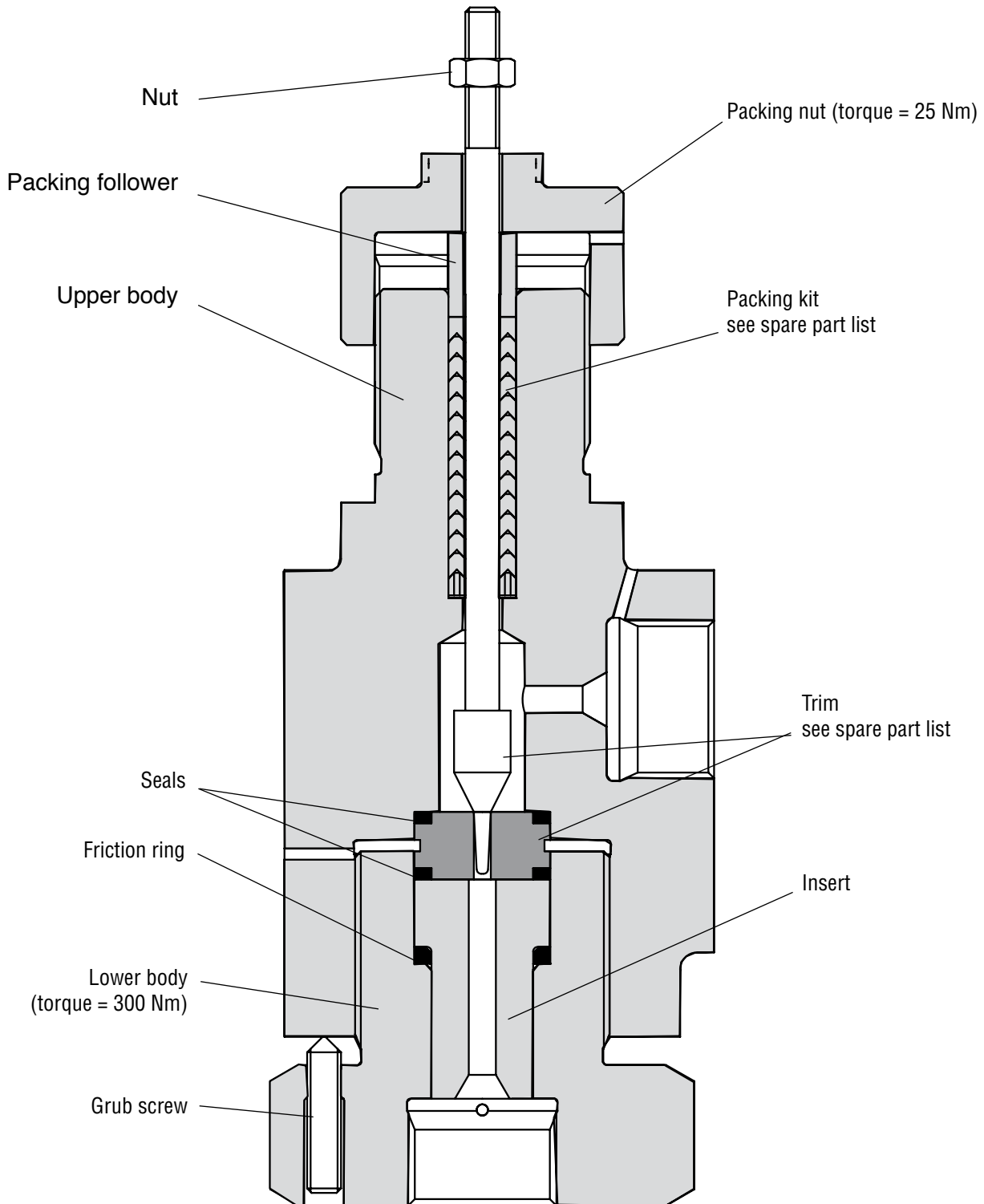

**Fig. 2**



6.4.3 Unscrew the coupling insert until the yoke rods are raised from the lower yoke plate by around 2 mm.

**CAUTION: Ensure that the plug assembly is not rotated with the plug seated. This may cause irreparable damage to the seating faces.**

6.4.4 Refit the coupling, ensuring that the arrows, embossed on the coupling halves, point upward towards the actuator, and secure with 2 retaining screws.

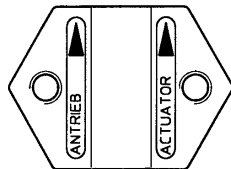

6.4.5 Apply supply pressure resp. vent actuator to half stroke and refit and tighten yoke rod retaining nuts).

6.4.6 Connect all tubing.

## 7 DISASSEMBLE AND ASSEMBLE VALVE.

### 7.0 Remove actuator

To disassemble the actuator first remove the actuator (see para. 6 of this manual).

**!** **Note: Large actuators may require the use of lifting equipment. Lift by slings attached to the lugs provided or through the yoke rods. Be aware that the centre of gravity may be above the attachment point and the actuator must be supported to prevent it rotating. Ensure the actuator is lifted absolutely straight up to prevent damage to the plug and seat.**

### 7.1 Disassemble valve

(see Fig. 2)

7.1.1 Loosen grub screw and remove the lower body.

**!** **Note: The insert and seat ring are placed loosely in the upper body. When the lower body is removed ensure that the insert and seat ring do not fall to the ground and are damaged**

7.1.2 Remove insert and seat ring.

7.1.3 Remove the nut from the plug stem and carefully press the plug stem out of the upper housing.

7.1.4 Check that the sealing and seating faces on insert, seat ring, plug, plug stem upper and lower housing are damage free and clean.

7.1.5 Press guides, packing and packing follower from below using a drift (the drift must have a slightly larger diameter than the plug stem).

**!** **NOTE: To prevent damage to the plug or plug stem, follow the above instructions precisely.**

7.1.6 If it is necessary to rework a sealing surface then lap this only.

7.1.7 If a seat surfaces need re-machining, seat and plug seating surfaces must be reworked. The seat angle on the plug is 30°, on the seat ring 25°. If the valve is correctly assembled, lapping is not required.

**!** **NOTE: When re-machining the plug, protect plug stem from damage. The seat surface must be concentric to the plug stem. When re-finishing the seat, the seat surface must be concentric to the seat outer diameter.**

### 7.2 Assemble valve (see Fig. 2)

7.2.1 All worn or damaged parts must be replaced. Reusable parts must be clean. Expendable parts such as gaskets and packing should always be replaced.

7.2.2 Carefully guide plug stem through the bonnet, to avoid damage.

7.2.3 Replace packing by inserting packing rings one at a time tapping each one down with a suitable bushing.

7.2.4 Insert packing follower. Fit packing nut for transport purposes only. Gland nut to be fitted correctly and tightened down when actuator is mounted (see table 1).

**!** **Note: After attaching the actuator tighten the packing nut to 25 Nm**

7.2.5 Replace seat ring, insert and seals.

7.2.6 Replace lower body and tighten to 300 Nm. Secure the lower body by tightening the grub screw.

**!** **Note: The lower body must be inserted slowly and absolutely straight to avoid damage to the insert, seat ring and seals. When inserting and tightening the lower body the plug must be in the raised position clear of the seat.**

7.2.7 Before the valve is returned to its application it must be tested for pressure and leaks to the standards quoted in the original order.

**8 Troubleshooting Chart**

<b>Fault</b>	<b>Possible Cause</b>	<b>Remedy</b>
Stem motion impeded	<ol style="list-style-type: none"> <li>1. Packing excessively tightened</li> <li>2. Operating temperature too high for selected trim</li> <li>3. Supply pressure inadequate</li> <li>4. Positioner defective</li> </ol>	<ol style="list-style-type: none"> <li>1. Tighten gland nut with correct torque</li> <li>2. Note operating data and contact dealer</li> <li>3. Check system for leaks in the supply pressure or signal lines. Retighten the connections, if necessary replace leaky lines</li> <li>4. See operating instructions for positioner</li> </ol>
Excessive leakage	<ol style="list-style-type: none"> <li>1. Body loose</li> <li>2. Worn or damaged seat ring/plug</li> <li>3. Gaskets damaged</li> <li>4. Inadequate actuator thrust</li> <li>5. Plug incorrectly adjusted</li> <li>6. Incorrect direction of flow</li> <li>7. Handwheel incorrectly adjusted (acts like end stop)</li> </ol>	<ol style="list-style-type: none"> <li>1. See step 7.2.6 for correct tightening of lower body.</li> <li>2. Re-machine or replace seat ring/plug.</li> <li>3. Replace gaskets</li> <li>4. Check air feed. If air feed is OK, contact dealer.</li> <li>5. Correctly adjust plug according to step 6.2.4</li> <li>6. Check specification. Contact dealer</li> <li>7. Adjust handwheel</li> </ol>
Inadequate flow	<ol style="list-style-type: none"> <li>1. Plug incorrectly adjusted (short stroke)</li> <li>2. Positioner defective</li> <li>3. Operating requirements too high</li> </ol>	<ol style="list-style-type: none"> <li>1. Correctly adjust plug according to step 6.2.4</li> <li>2. See operating instructions for positioner</li> <li>3. Check operating data. Contact dealer</li> </ol>
Plug slams	<ol style="list-style-type: none"> <li>1. Plug adjustment incorrect</li> <li>2. Inadequate supply pressure</li> <li>3. Trim too large for flow rate</li> </ol>	<ol style="list-style-type: none"> <li>1. Correctly adjust plug according to step 6.2.4</li> <li>2. Check supply pressure, seal leaks, remove blockage</li> <li>3. Replace trim</li> </ol>

**Regional Headquarters**
**Flowserve**

Manderscheidtstr. 19  
45141 Essen  
Germany  
Telephone: +49 (0) 201 8919 5  
Facsimile: +49 (0) 201 8919 662

**Flowserve**

1350 N. Mt. Springs Prkwy.  
Springville, UT 84663  
USA  
Telephone: +1 801 489 8611  
Facsimile: +1 801 489 3719

**Flowserve**

12 Tuas Avenue 20  
Singapore 638824  
Telephone: +65 862 3332  
Facsimile: +65 862 4940

**Main Sales Offices (Europa, Middle east, Africa)**
**Flowserve**

von-Braun-Straße 19a  
48681 Ahaus  
Germany  
Telephone: +49 (0) 2561 6860  
Facsimile: +49 (0) 2561 68648

**Flowserve**

12, av. du Québec  
91965, Courtaboeuf Cedex  
France  
Telephone: +33 (0) 1 60 923 251  
Facsimile: +33 (0) 1 60 923 299

**Flowserve**

Station Road  
Pershore, Worcestershire  
England WR102BZ  
Telephone: +44 (0) 1386 55 45 51  
Facsimile: +44 (0) 1386 55 49 68

**Flowserve**

Allee du Quartz 1  
CH-2300 La-Chaux-de Fonds  
Switzerland  
Telephone: +41 (0) 32 925 9700  
Facsimile: +41 (0) 32 926 5422

**Flowserve**

Cnr. Bismit and Granier Str.  
Jet Park Ext 3  
Boksburg  
1459 Gauteng  
South Africa  
Telephone: +27 397-3150  
Facsimile: +27 397-5300/01/02

**Flowserve**

C/O Saleh & Abdulaziz Abahsain  
P.O. Box 209  
Al Khobar 31952  
Saudi Arabia  
Telephone: 9663 857 3442  
Facsimile: 9663 859 5284