

Increase mechanical seal reliability without the installation, maintenance and cost associated with cooling water

The AFC Seal Cooler is a forced draft system that increases performance of finned pipe designs by boosting airflow across the cooling coil. It increases mechanical seal reliability by removing heat and reducing fluid temperature without cooling water.

The AFC Seal Cooler can be applied to multiple seal support systems, including piping plans 21, 23, 53B and 53C.

Features and benefits

- Unique conical design optimizes heat transfer
- Fully compliant with API 682 4th Edition with large tube size to maximize flow
- Designed to ASME B31.3 process piping standards
- Corrosion-resistant materials used throughout; suitable for marine environments
- Minimize operating and maintenance costs by eliminating the need for cooling water
- Compact design simplifies installation and maintenance, including easy cleaning, venting and draining
- Robust welded fins can be cleaned with power washers
- Optional certifications available:
 - ATEX assembly with PED
 - ATEX motor (only)
 - NEC/CSA explosion-proof motor

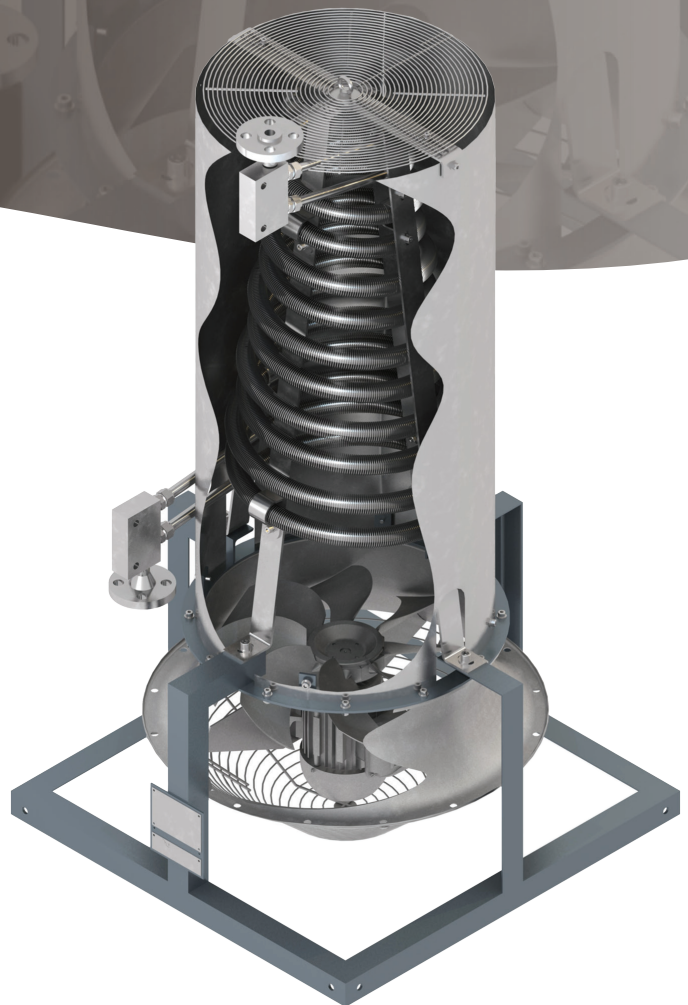

Model numbers

Example:	Model	Cooler type	Connections	Motor selection	Certifications
AFC12P1500M1-P	AFC	12P	1500	M1	-P
AFC					
12 m parallel: 12P					
Flange rating Class 1500: 1500 Flange rating Class 600: 0600 Flange rating Class 300: 0300 NPT: 0000					
ATEX motor: M1 NEC/CSA motor: M2					
PED compliance: -P					

Technical details

Maximum pressure	200 bar (2,900 psig) @ 371°C (700°F)
Maximum temperature	371°C (700°F)

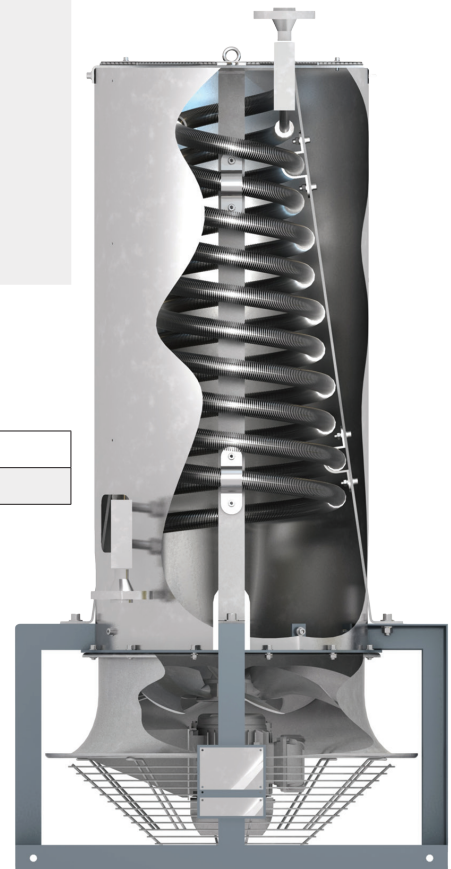

SSFLY000324 (EN/A4) July 2021

Headquarters

Flowserve Corporation
5215 North O'Connor Blvd.
Suite 700
Irving, Texas 75039-5421 USA
Telephone: +1 937 890 5839

USA and Canada

Kalamazoo, Michigan USA
Telephone: +1 269 381 2650

Europe, Middle East, Africa

Etten-Leur, The Netherlands
Telephone: +31 765 028 200

Asia Pacific

Singapore
Telephone: +65 6544 6800

Latin America

Mexico City
Telephone: +52 55 5567 7170

Flowserve Corporation has established industry leadership in the design and manufacture of its products. When properly selected, this Flowserve product is designed to perform its intended function safely during its useful life. However, the purchaser or user of Flowserve products should be aware that Flowserve products might be used in numerous applications under a wide variety of industrial service conditions. Although Flowserve can provide general guidelines, it cannot provide specific data and warnings for all possible applications. The purchaser/user must therefore assume the ultimate responsibility for the proper sizing and selection, installation, operation, and maintenance of Flowserve products. The purchaser/user should read and understand the Installation Instructions included with the product, and train its employees and contractors in the safe use of Flowserve products in connection with the specific application.

While the information and specifications contained in this literature are believed to be accurate, they are supplied for informative purposes only and should not be considered certified or as a guarantee of satisfactory results by reliance thereon. Nothing contained herein is to be construed as a warranty or guarantee, express or implied, regarding any matter with respect to this product. Because Flowserve is continually improving and upgrading its product design, the specifications, dimensions and information contained herein are subject to change without notice. Should any question arise concerning these provisions, the purchaser/user should contact Flowserve Corporation at any one of its worldwide operations or offices.

©2021 Flowserve Corporation. All rights reserved. This document contains registered and unregistered trademarks of Flowserve Corporation. Other company, product, or service names may be trademarks or service marks of their respective companies.