

Valtek® FlowTop V750 / V752 General Service Control Valve

NPS ½ to 6, Class 150 and 300



Engineered for maximum performance and value

The newly redesigned Valtek FlowTop general service control valve provides process plant operators with the perfect balance of high-efficiency performance, low total cost of ownership (TCO) and versatility. A new standardized globe body assembly as well as multiple pre-engineered seating and packing options make the Valtek FlowTop control valve highly configurable and a good value for general service applications in the oil and gas, chemical, power and general industries.

A complete integrated solution

The Valtek FlowTop linear control valve is a fully integrated valve package. Available globally, it includes:

- Standardized FlowTop globe body assembly
- Logix™ 3800e digital positioner (with automatic calibration) option
- FlowAct pneumatic diaphragm actuator

Designed to deliver continuous process flow control throughout the plant, the Valtek FlowTop valve's integrated design delivers best-in-class performance with:

- Quick installation and simple setup
- Finite flow control accuracy
- Direct-mounted digital positioner without tubing (air-to-open)
- Trim and material options to handle virtually all general service requirements
- Severe service trim options to manage noise and cavitation
- Excellent rangeability, repeatability and high flow rates

Optimized design

Building on the proven FlowTop GS and Valtek GS control valves, the Valtek FlowTop valve now provides one model with proven efficiency and more versatility; a standardized globe body assembly and multiple trim and packing options are available to meet a broad range of general service requirements. Without any concession to product quality or reliability, the new FlowTop valve offers the same performance and options in a simplified product that's extremely easy to size, select, order and configure. What's more, it's also an economical solution to buy, install, operate and maintain. The fully integrated valve, actuator and positioner package is available globally and includes an inline globe-style body plus a cost-competitive digital positioner with automatic calibration and a FlowAct pneumatic diaphragm actuator.

Benefits

- **Maximum-capacity flow rates:** The FlowTop valve handles a wide selection of process control applications for high-flow applications in the oil and gas, chemical, power and general service industries.
- **Smaller, lighter and more cost-effective:** Achieves maximum-flow capacity that outperforms competing brands with a smaller, lighter and cost-effective control valve
- **Deep packing box:** Permits a variety of packing configurations in addition to the standard ISO 15848-1 and optional live-loaded emission control packing. The packing set is positioned far enough away from the flow in the body to avoid damage from the flowing medium.
- **Contoured plug design:** Is readily adaptable for modified equal percentage, linear and quick-open flow characteristics. And it can be matched to a variety of trim types, providing excellent rangeability, repeatability and resolution.
- **Guiding solutions:** Post guiding ensures stabilized plug and stem during valve travel; minimizes vibration and wear.
- **Clamped seat ring:** Comes standard and offers tight shutoff and easy removal without special tools or the galling problems associated with threaded seat rings.
- **Ease of maintenance:** Maintenance is simplified due to the unified design with compatible parts; global technical and engineering service provide fast and dependable support.

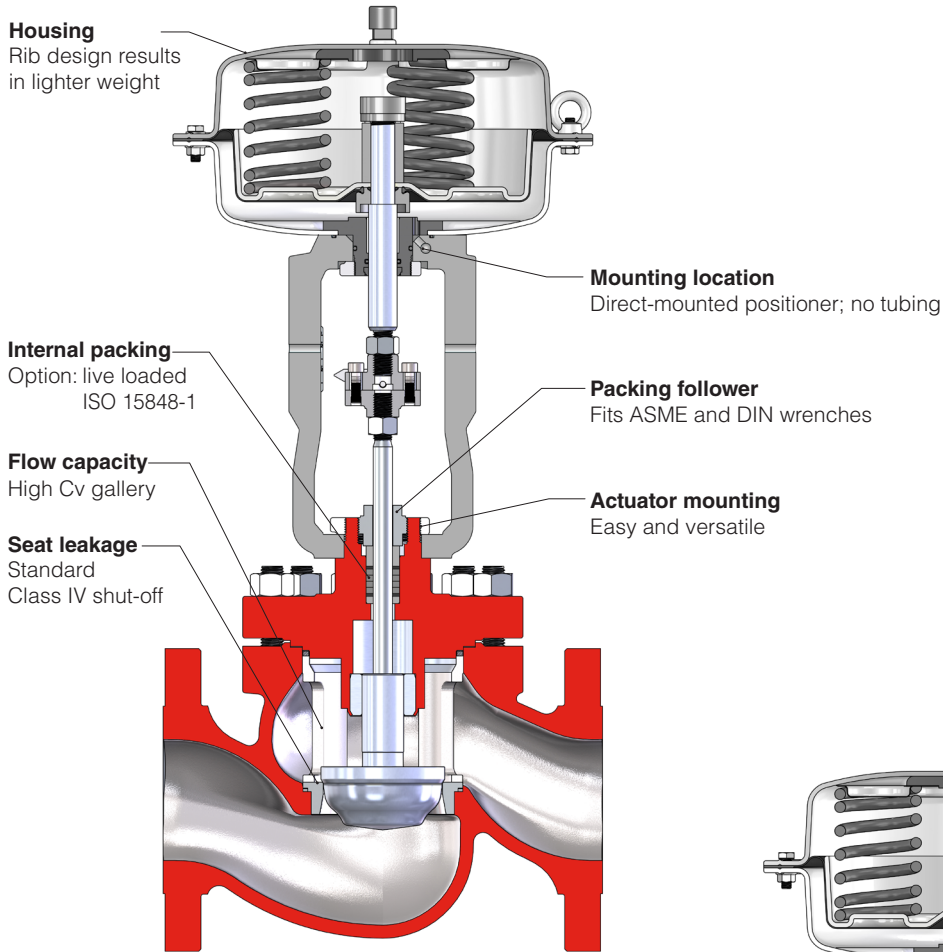

Figure 1: Clamped seat ring design

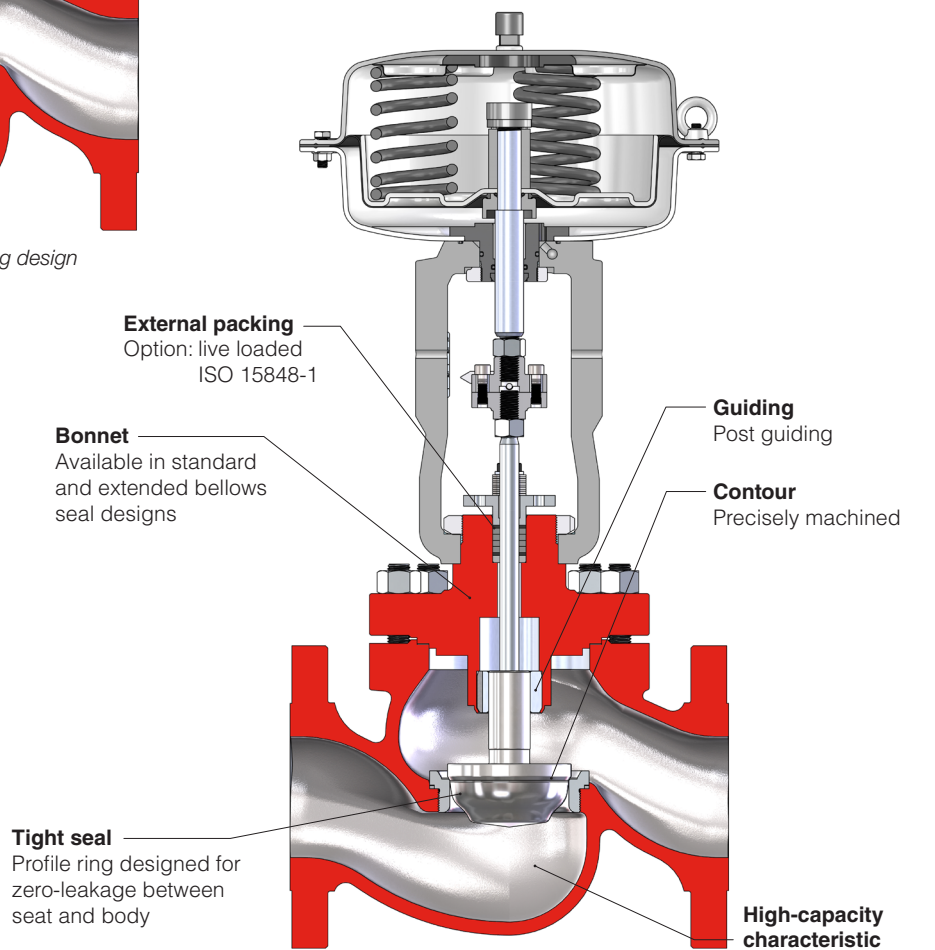

Figure 2: Screwed seat ring design

Specifications

Style	Globe, integral flange, ASME B16.34
Sizes	NPS ½ to 6
Pressure classes	ASME Class 150 and 300
End connection	Flanged, raised face (RF)
Body materials	ASTM A216 grade WCC, ASTM A351 grade CF8M, ASTM A351 grade CF3M
Face-to-face	ISA 75.08.01
Bonnet	Standard, extended or bellows seal
Packing	Internal or external, PTFE and graphite, live loaded, ISO 15848-1 or vacuum

Trim material	410, 316 or 316L stainless steel
Trim types	Standard, pressure balanced
Plug and seat facing	Seat or full contour Alloy 6 hardened
Characteristic	Equal percent, linear or quick open
Low noise and anti-cavitation	MegaStream™ one-stage CavStream™ one-stage
Leakage rates	Class IV, V or VI with optional soft seat
Actuator	Pneumatic diaphragm spring actuator
Standard positioner	Digital positioner; also available as integrally mounted to yoke for fail-close/air-to-open configuration; no tubing or bracket required

Body design – integral flange

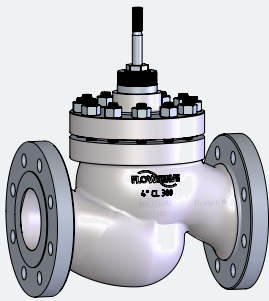
Body Design	Pressure Class	Size	Body Material	Bonnet Design	Packing Design	Trim Design
Integral flange 	Class 150 300	NPS ½ ¾ 1 1½ 2 3 4 6	A216 WCC A351 CF8M A351 CF3M	Unbalanced: Standard bonnet Bellows seal bonnet Extended bonnet O-ring pressure balanced: Standard bonnet Extended bonnet <i>See pages 6 and 7</i>	Unloaded: PTFE and graphite Live loaded: PTFE and graphite ISO 15848-1 vacuum <i>See page 8</i>	Contoured plug – standard Soft seated Severe service trim options: MegaStream (one-stage) CavStream (one-stage) <i>See page 9</i>

Body connecting design detail

Body Design	Face-to-Face	End Connections		
Integral flange	ASME/ISA 75.08.01-2002	ASME B16.5	Raised-face (RF)	$R_a = 3.2$ to $6.3 \mu\text{m}$ (125 to 250 $\mu\text{in.}$)

Body pressure/temperature ratings

Pressure Class	Body Material	Maximum Allowable Working Pressure, bar											
		Service Temperature in °C											
		-46	-29	-10	50	100	150	200	250	300	350	400	425
150	ASTM A216 WCC	—	19.8	19.8	19.5	17.7	15.8	13.8	12.1	10.2	8.4	6.5	5.5
	ASTM A315 CF8M	19.0	19.0	19.0	18.4	16.2	14.8	13.7	12.1	10.2	8.4	6.5	5.5
	ASTM A351 CF3M	19.0	19.0	19.0	18.4	16.2	14.8	13.7	12.1	10.2	8.4	6.5	5.5
300	ASTM A216 WCC	—	51.7	51.7	51.7	51.5	50.2	48.6	46.3	42.9	40.0	34.7	28.8
	ASTM A315 CF8M	49.6	49.6	49.6	48.1	42.2	38.5	35.7	33.4	31.6	30.3	29.4	29.1
	ASTM A351 CF3M	49.6	49.6	49.6	48.1	42.2	38.5	35.7	33.4	31.6	30.3	29.4	29.1
Pressure Class	Body Material	Maximum Allowable Working Pressure, psig											
		Service Temperature in °F											
		-51	-20	14	122	212	302	392	482	572	662	752	797
150	ASTM A216 WCC	—	287	287	282	256	229	200	175	147	121	94	79
	ASTM A351 CF8M	275	275	275	266	235	214	198	175	147	121	94	79
	ASTM A351 CF3M	275	275	275	266	235	214	198	175	147	121	94	79
300	ASTM A216 WCC	—	749	749	749	747	728	704	671	622	580	503	417
	ASTM A351 CF8M	719	719	719	697	612	558	517	484	458	439	426	422
	ASTM A351 CF3M	719	719	719	697	612	558	517	484	458	439	426	422

Bonnet design — unbalanced, NPS ½ to 6

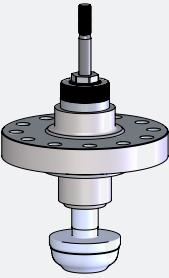
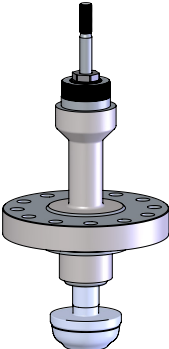
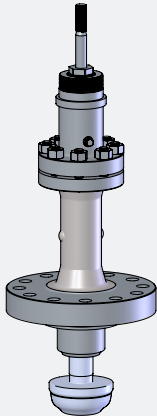
Type (Bonnet)	Body Material	Bonnet Material	Temperature Range ⁽¹⁾	Application	Packing Design
Standard bonnet 	ASTM A216 WCC	ASTM A105 ASTM A216 WCC	-29°C to 250°C (-20°F to 482°F)	Universal use	See page 8
	ASTM A351 CF8M	ASTM A182 F316 ASTM A351 CF8M	-46°C to 250°C (-51°F to 482°F)		
	ASTM A351 CF3M	ASTM A182 F316L ASTM A351 CF3M			
Extended bonnet 	ASTM A216 WCC	ASTM A105 ASTM A216 WCC	251°C to 425°C (483°F to 797°F)	Extends the upper temperature limitations	
	ASTM A351 CF8M	ASTM A182 F316 ASTM A351 CF8M			
	ASTM A351 CF3M	ASTM A182 F316L ASTM A351 CF3M			
Bellows seal bonnet 	ASTM A216 WCC	ASTM A105 ASTM A216 WCC	-29°C to 400°C (-20°F to 752°F)	Use for hazardous, costly media or vacuum	
	ASTM A351 CF8M	ASTM A182 F316 ASTM A351 CF8M	-46°C to 400°C (-51°F to 752°F)		
	ASTM A351 CF3M	ASTM A182 F316L ASTM A351 CF3M			

Bonnet design — pressure balanced, NPS 3 to 6

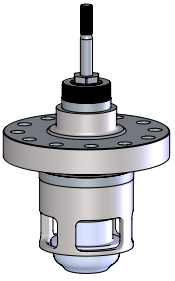
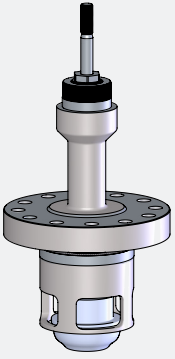
Type (Bonnet)		Body Material	Bonnet Material	Temp. Range ⁽¹⁾	Balancing	Application	Packing Design
Standard bonnet		ASTM A216 WCC	ASTM A105 ASTM A216 WCC	-40°C to 121°C (-40°F to 250°F)	Buna-N+ Filled PTFE	Universal use	See page 8
				-46°C to 177°C (-51°F to 350°F)	EPDM + PEEK®		
		ASTM A351 CF8M	ASTM A182 F316 ASTM A351 CF8M	-26°C to 204°C (-15°F to 400°F)	Viton®+ Filled PTFE		
Extended bonnet		ASTM A216 WCC	ASTM A105 ASTM A216 WCC	251°C to 315°C (484°F to 599°F)	Kalrez® 4079+ Filled PEEK	Extends the upper temperature limitations	
		ASTM A351 CF3M	ASTM A182 F316L ASTM A351 CF3M		Chemraz® 555+ Filled PEEK		

1) The actual temperature range is limited by the used stem material and packing material.

® PEEK is a registered trademark of Victrex plc Corp.

® Viton and Kalrez are registered trademarks of the DuPont Company.

Temperature guidelines for trim combinations

Temperature Range	Plug and Seat Materials	Stem Material	
		Standard	NACE
-29°C to 250°C (-20°F to 482°F)	416 SS	316L SH L2	A479 XM19
-29°C to 250°C (-20°F to 482°F)	316 SS	316L SH L2	A479 XM19
251°C to 425°C (484°F to 797°F)	416 SS	A479 XM19-H	A479 XM19
251°C to 425°C (484°F to 797°F)	316 SS	A479 XM19-H	A479 XM19
-46°C to 400°C (-51°F to 752°F)	316L SS	A479 XM19-H	Option not available
-46°C to 400°C (-51°F to 752°F)	316 SS	A479 XM19-H	Option not available

Packing design – detail

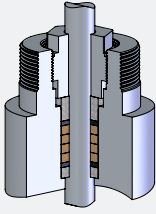
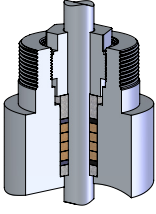
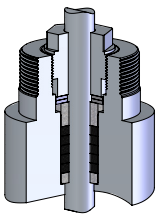
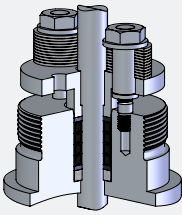
Packing Design	Type (Packing)	Material	Temperature Range	Application	Approvals
Internal unloaded	Braided PTFE	 Packing rings Braided PTFE Chamber washers Braided PTFE-carbon	Standard bonnet -46°C to 250°C (-50°F to 482°F)	Universal chemical resistance	-
	Braided graphite		Extended bonnet -46°C to 300°C (-50°F to 572°F)		
Internal live loaded	Braided PTFE	 Packing rings Braided PTFE Chamber washers Braided PTFE-carbon	Standard bonnet -46°C to 250°C (-50°F to 482°F)	Universal chemical resistance Vacuum < 0.3 mbar	ISO 15848-1 (10^{-4} mg * s ⁻¹ * m ⁻¹) Tightness class → B Endurance class → CC1
	Braided PTFE		Extended bonnet -46°C to 300°C (-50°F to 572°F)	Universal chemical resistance	-
	Braided graphite	 Packing rings graphite rib-braid	301°C to 400°C (573°F to 752°F)	Universal chemical resistance Vacuum < 0.3 mbar	ISO 15848-1 (10^{-2} mg * s ⁻¹ * m ⁻¹) Tightness class → C Endurance class → CC1
	Braided graphite		Packing rings Braided graphite	301°C to 425°C (573°F to 797°F) (Below 250 °C increased friction)	Universal chemical resistance
External live loaded	Braided PTFE	 Packing rings PTFE Chamber washers PTFE-carbon	Standard bonnet -46°C to 250°C (-50°F to 482°F)	Universal chemical resistance Vacuum < 0.3 mbar	ISO 15848-1 (10^{-4} mg * s ⁻¹ * m ⁻¹) Tightness class → B Endurance class → CC1
	Braided graphite		Packing rings graphite rib-braid	301°C to 400°C (573°F to 752°F)	Universal chemical resistance Vacuum < 0.3 mbar

Standard trim design

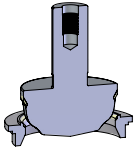
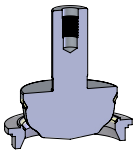
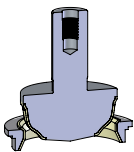
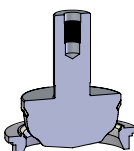
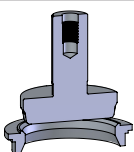
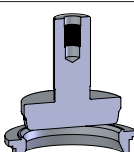
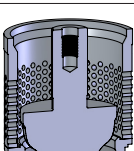
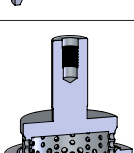
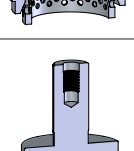
Trim Type	Trim Material		Medium	Flow Direction	Max. Allowable Differential Pressure	Noise Reduction
Contoured plug Characteristic: Equal percent or linear	Standard: 416 SS, 316 SS		<ul style="list-style-type: none"> • Clean • Marginally contaminated with particles • Low clogging potential for dirty service 	Under the plug	Contact Flowserve	None - Noise insulating provided by customer
	Seat surface: Alloy 6 316 SS (From seat Ø 53 mm)					
	Full contour: Alloy 6 316 SS					
	Soft seated: 416 SS, 316 SS +PTFE					
Quick-open with throttle lip Characteristic: On/off	Standard: 416 SS, 316 SS			Under the plug; flow over the plug possible for gases and vapors	Contact Flowserve	
	Soft seated: 416 SS, 316 SS +PTFE					
Contoured plug with MegaStream	All standard trim		Gases and vapors	Under the plug	Contact Flowserve	Maximum = 12 dB(A)
CavStream	Standard: 416 SS HT 316 SS tenifer treated		<ul style="list-style-type: none"> • Clean • High clogging potential for dirty service 	Liquids	Contact Flowserve	Maximum = 10 dB(A)
	Seat surface: Alloy 6 316 SS 316L SS					

Valve characteristic

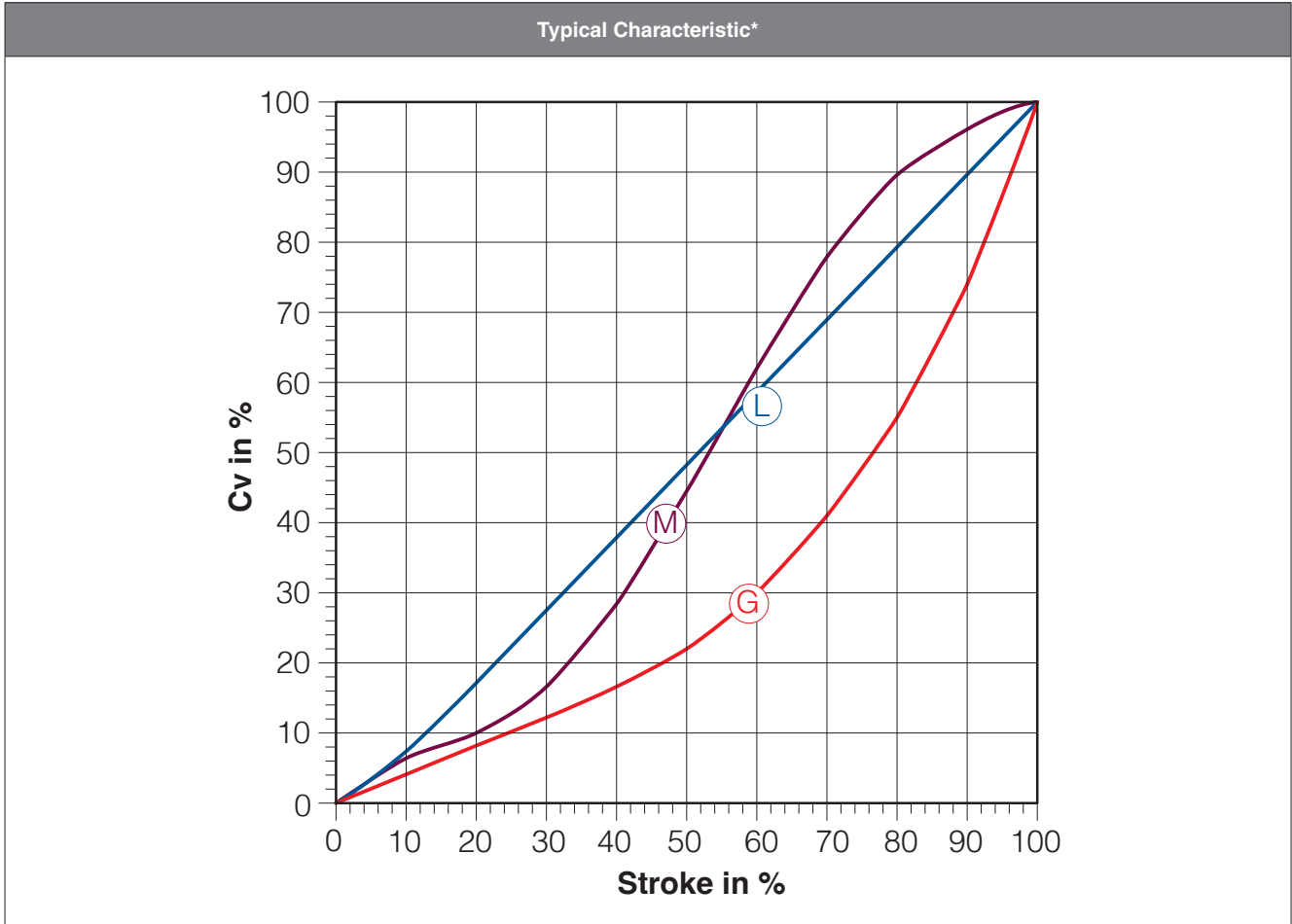

Application

Equal percent flow characteristic

- The equal percent characteristic is used for highly changeable differential pressure.
- A “soft” inlet characteristic alleviates pressure impulses for short closing times.
- The equal percent characteristic relates equal increments of travel to equal percent increments of the corresponding Cv value.
- The equal percent characteristic is recommended for a pressure ratio of $\Delta p_0 / \Delta p_{100} > 2$

Linear flow characteristic

- The linear characteristic is used for constant differential pressure under different loads.
- The linear characteristic relates equal increments of travel to equal increments of the Cv value.
- The linear characteristic is recommended for a pressure ratio of $\Delta p_0 / \Delta p_{100} > 1 < 2$
- The L-curve is used for all trim designs. The M-curve is used for contoured plug and MegaStream. The G-curve is used for contoured plug and CavStream.

* Typical flow curves. For illustration purposes only.

Trim details—contoured plug; equal percent or linear

Cv by NPS, stroke and seat diameter

Seat Ø (mm)	Pressure Balanced	Cv							
		NPS and Stroke Length							
		½	¾	1	1½	2	3	4	6
20 mm (0.787 in.)				40 mm (1.574 in.)		60 mm (2.362 in.)			
8		1.16	1.16	1.16					
8		1.8	1.8	1.8					
10		2.9	2.9	2.9					
12		4.6	4.6	4.6					
16		6.5							
16			7.3	7.3	7.3				
20			9.2						
20				11.6	11.6	11.6			
25				16.2					
25					18.5	18.5			
34					29	29	29	29	
40					36				
42						46	46		
50						55			
53	73 ⁽²⁾						73	73	
67	116						116	116	
67	116								116
80	145						145		
84	185							185	185
100	208							208	
105	289								289
130	410								410

Plug material and seat design by seat diameter

Seat Ø (mm)	Pressure Balanced	Plug Material and Seat Design						
		416 SS			316 SS, 316L SS			
		Standard	Hardened	Soft Seated ⁽¹⁾	Standard	Seat surface: Alloy 6	Full Contour: Alloy 6	Soft Seated ⁽¹⁾
8		•	•	•	•		•	•
8		•	•	•	•		•	•
10		•	•	•	•		•	•
12		•	•	•	•		•	•
16		•	•	•	•		•	•
16		•	•	•	•		•	•
20		•	•	•	•		•	•
20		•	•	•	•		•	•
25		•	•	•	•		•	•
25		•	•	•	•		•	•
34		•	•	•	•		•	•
40		•	•	•	•		•	•
42		•	•	•	•		•	•
50		•	•	•	•		•	•
53	• ⁽²⁾	•	•	•	•	•	•	•
67	•	•	•	•	•	•	•	•
67	•	•	•	•	•	•	•	•
80	•	•	•	•	•	•	•	•
84	•	•	•	•	•	•	•	•
90	•	•	•	•	•	•	•	•
100	•	•	•	•	•	•	•	•
105	•	•	•	•	•	•	•	•
130	•	•	•	•	•	•	•	•

1) Maximum allowable working temperature with PTFE soft seat = -46°C to 250°C (-51°F to 482°F) only

2) Pressure balancing not for 6 in.

Trim details—contoured plug with MegaStream trim; equal percent or linear

Cv by NPS, stroke and seat diameter

Seat Ø (mm)	Pressure Balanced	Cv					
		NPS and Stroke Length					
		1	1½	2	3	4	6
20 mm (0.787 in.)			40 mm (1.574 in.)		60 mm (2.362 in.)		
16		6.4					
20		10.1					
25		14.4					
25			16				
34			26	26			
40			33				
42				41	41		
50				51			
53	65				65	65	99
67	99				99	99	
80	129				129		
84	165					165	165
100	190					190	
105	257						257
130	370						370

Plug material and seat design by seat diameter

Seat Ø (mm)	Pressure Balanced	Plug Material and Seat Design						
		416 SS			316 SS, 316L SS			
		Standard	Hardened	Soft Seated ⁽¹⁾	Standard	Seat Surface: Alloy 6	Full Contour: Alloy 6	Soft Seated ⁽¹⁾
16		•	•	•	•		•	•
20		•	•	•	•		•	•
25		•	•	•	•		•	•
25		•	•	•	•		•	•
34		•	•	•	•		•	•
40		•	•	•	•		•	•
42		•	•	•	•		•	•
50		•	•	•	•		•	•
53	•	•	•	•	•	•	•	•
67	•	•	•	•	•	•	•	•
80	•	•	•	•	•	•	•	•
84	•	•	•	•	•	•	•	•
90	•	•	•	•	•	•	•	•
100	•	•	•	•	•	•	•	•
105	•	•	•	•	•	•	•	•
130	•	•	•	•	•	•	•	•

1) Maximal allowable working temperature with PTFE soft seat = -46°C to 250°C (-51°F to 482°F) only

Trim details—CavStream trim; equal percent or linear

Cv by NPS, stroke and seat diameter

Seat (mm)	Cv												
	Pressure Balanced	NPS and Stroke Length											
		1		1.5		2		3		4		6	
		20 mm (0.787 in.)						40 mm (1.574 in.)				60 mm (2.362 in.)	
	Linear	Linear	Equal Percent	Linear	Equal Percent	Linear	Equal Percent	Linear	Equal Percent	Linear	Equal Percent	Linear	Equal Percent
20		4.2	3.4										
25		7.1	5.8										
25				8.0	6.5								
34				15	12								
34						17	13						
40				20	16								
42						21	17						
50						30	25						
42								37	29				
53	Optional							57	46				
53	Optional									60	48		
67	Optional							73	58				
80	Optional							92	68				
67	Optional									79	61		
84	Optional									104	84		
100	Optional									145	110		
67	Optional											100	86
84	Optional											145	116
105	Optional											203	163
130	Optional											271	218

Plug material and seat design by seat diameter

Seat Ø (mm)	Pressure Balanced	Plug Material and Seat Design		
		416 SS	316 SS, 316L SS	
		Hardened	Seat Surface: Alloy 6	Full Contour: Alloy 6
20		•		•
25		•		•
25		•		•
34		•		•
34		•		•
40		•		•
42		•		•
50		•		•
42		•		•
53	•	•		•
53	•	•		•
67	•	•		•
67	•	•		•
80	•	•		•
90	•	•	•	•
84	•	•	•	•
100	•	•	•	•
105	•	•	•	•
130	•	•	•	•

Trim details—quick open; on/off

Cv by NPS, stroke and seat diameter

Seat Ø (mm)	Pressure Balanced	Cv							
		NPS and Stroke Length							
		½	¾	1	1½	2	3	4	6
20 mm (0.787 in.)					40 mm (1.574 in.)		60 mm (2.362 in.)		
16		7.3							
20			10.4						
25				18.5					
40					41				
50						61			
80	162						162		
100	231							231	
130	410								410

Plug material and seat design by seat diameter

Seat Ø (mm)	Pressure Balanced	Plug Material and Seat Design			
		416 SS		316 SS, 316 L	
		Standard	Soft Seated ⁽¹⁾	Standard	Soft Seated ⁽¹⁾
16		•	•	•	•
20		•	•	•	•
25		•	•	•	•
40		•	•	•	•
50		•	•	•	•
80	•	•	•	•	•
100	•	•	•	•	•
130	•	•	•	•	•

1) Maximum allowable working temperature with PTFE soft seat = -46°C to 250°C (-51°F to 482°F) only

Seat leakage, per ASME/FCI 70-2

Pressure Balanced	Plug Design	Leakage Class	Test Medium	Test Pressure	Maximum Seat Leakage	Leakage Code	
No	Metal to metal seated	IV	Liquid	Working pressure	0.000 1 · Kvs	IV L 2	
					0.000 1 · Cv		
			Gas	Working pressure, maximum 3.5 bar	0.000 1 · Kvs	IV G 1	
					Working pressure, maximum 50.7 psi		0.000 1 · Cv
	Metal to metal seated, lapped seat, increased seal force	V	Liquid	Working pressure	0.000 018 · Δp · Ø d ¹⁾		V L 2
					Gas	Working pressure, maximum 3.5 bar	0.000 010 8 · Ø d
			Working pressure, maximum 50.7 psi				
			Soft seated	VI	Gas	Working pressure, maximum 3.5 bar	0.3 · Δp · LF ²⁾
	Working pressure, maximum 50.7 psi						
Yes (O-ring)	Metal to metal seated	IV	Liquid	Working pressure	0.000 1 · Kvs	IV L 2	
					0.000 1 · Cv		
			Gas	Working pressure, maximum 3.5 bar	0.000 1 · Kvs	IV G 1	
					Working pressure, maximum 50.7 psi		0.000 1 · Cv
	Metal to metal seated, lapped seat, increased seal force	V	Liquid	Working pressure	0.000 018 · Δp · Ø d		V L 2
					Gas	Working pressure, maximum 3.5 bar	0.000 010 8 · Ø d
			Working pressure, maximum 50.7 psi				
			Soft seated	VI	Gas	Working pressure, maximum 3.5 bar	0.3 · Δp · LF
	Working pressure, maximum 50.7 psi						

1) Ø d = seat Ø

2) LF = Leakage factor; see IEC 60534-4, remark 2

Parts list

Standard materials of construction *(for rough orientation only, non-NACE)*

Item	Part	Materials		
1	Body	ASTM A216 WCC	ASTM A351 CF8M	ASTM A351 CF3M
5	Bonnet	ASTM A105 or ASTM A216 WCC	ASTM A182 F316 or ASTM A351 CF8M	ASTM A182 F316L or ASTM A351 CF3M
20	Seat ring	416 SS	316 SS	316L SS
30	Seat retainer	416 SS	316 SS	316L SS
	Sleeve	416 SS	316 SS (nitrided)	316L SS (nitrided)
40	Bonnet/head	ASTM A105 or ASTM A216 WCC	ASTM A182 F316 or ASTM A351 CF8M	ASTM A182 F316L or ASTM A351 CF3M
42	Plug screw	A2		
48	Plug gasket	Pure graphite		
50	Plug	416 SS	316 SS	316L SS
51	Stem	17-4PH (con. H1150D) or 316L SS (strain hardened level 2) or S31803 or ASTM A479 XM19-H		
52	Lock pushing	316 SS		
55	Profile ring	Pure graphite		
56	Seat retainer gasket	316 SS - graphite layer		
58	Bonnet gasket	316 SS - graphite layer		
59	Head gasket	Pure graphite		
60	Profile ring	Pure graphite		
65	O-ring	Buna-N, Viton, EPDM, Kalrez or Chemraz, depending on the operating temperature		
66	Backup ring	PTFE or PEEK, depending on the operating temperature		
80	Packing follower	316 SS		
87	Upper guiding	316 SS (nitrided)		
88	Packing	PTFE or graphite		
91	Seal carrier	316 SS		
93	Packing box ring	316 SS		
104	Hex nut	316 SS		
106	Stud bolt	ASTM A193 Grade B7	ASTM A193 B8 Class 2	
108	Stud bolt	ASTM A193 Grade B7	ASTM A193 B8 Class 2	
109	Stud bolt	ASTM A193 B8M2 Class 2B		
110	Hex nut	ASTM A194 Grade 2H	ASTM A194 Grade 8	
112	Washer	316 SS		
114	Hex nut	ASTM A194 Grade 2H	ASTM A194 Grade 8	
117	Hex nut	316L SS		
138	Belleville spring	1.4310		

Valtek FlowTop V750 / V752 General Service Control Valve

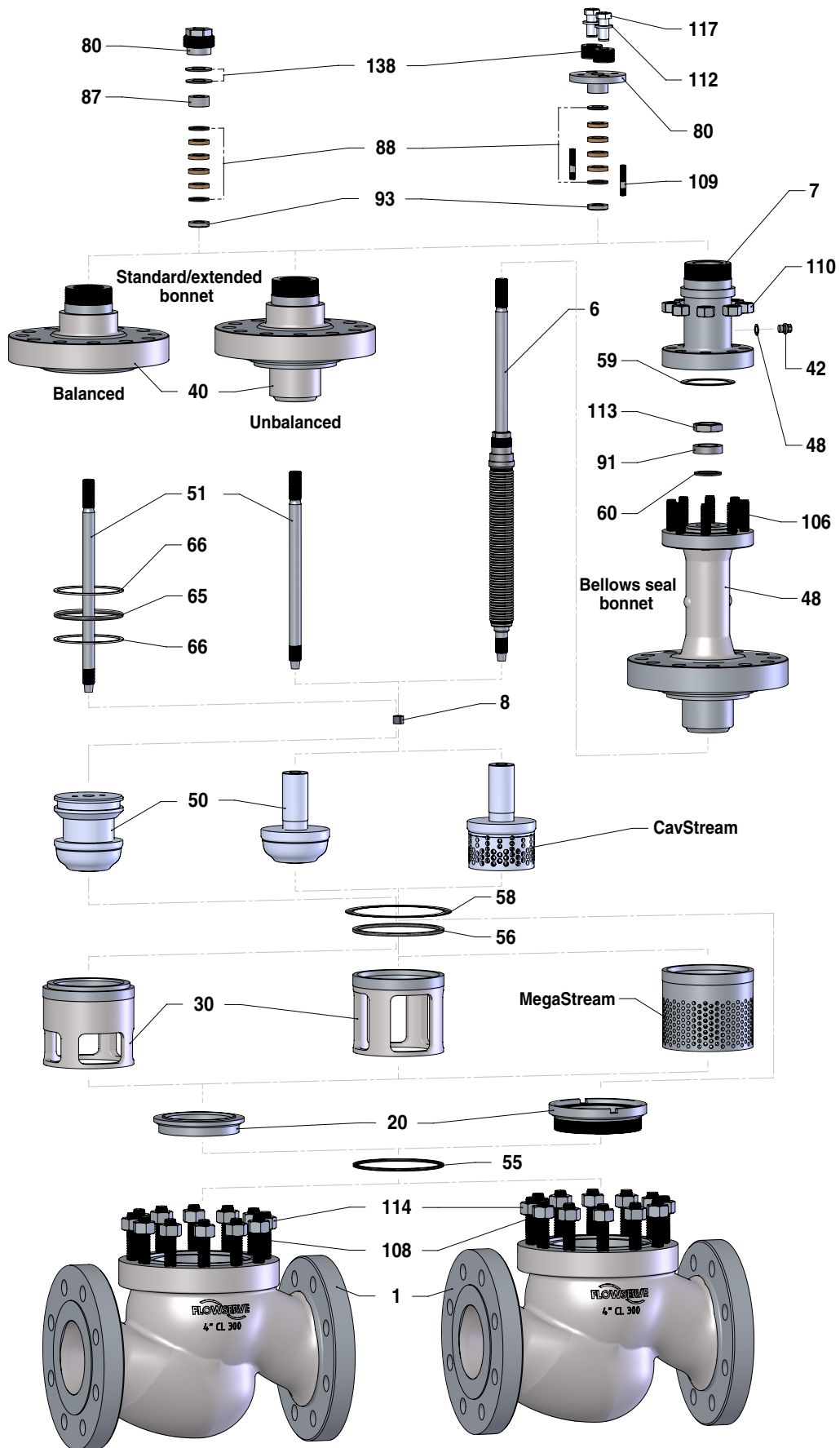

Dimensional drawing

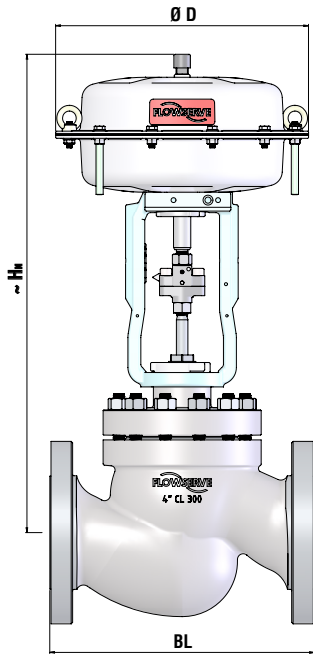

Valve with standard bonnet and pneumatic actuator

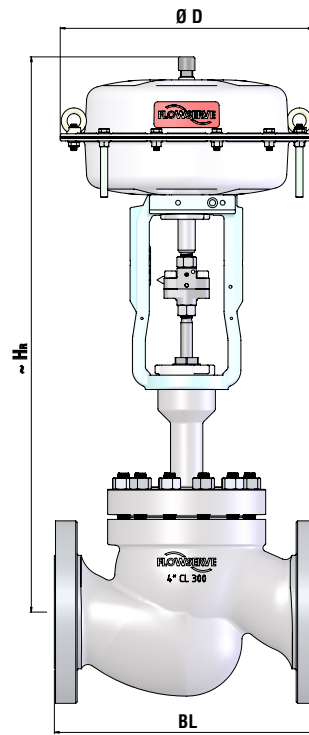

Valve with extension bonnet and pneumatic actuator

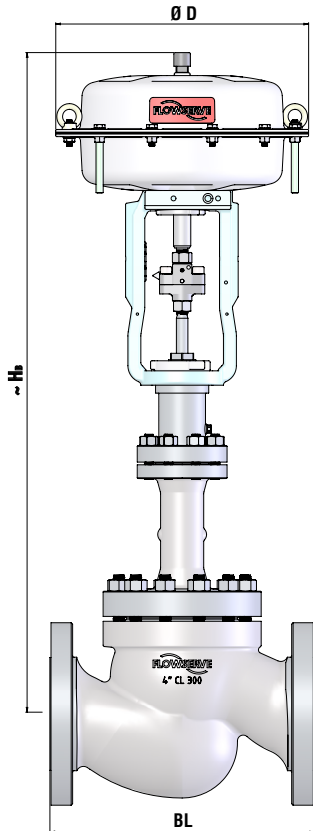

Valve with bellows seal bonnet and pneumatic actuator

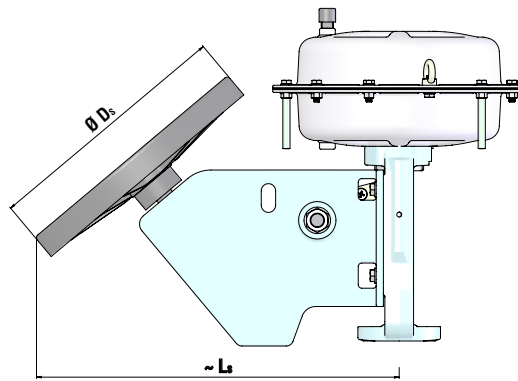

Actuator with side-mounted handwheel; for further data, see FlowAct valve technical bulletin

Dimensions and weights*

Description	Actuator		Nominal Size*							
	ASME — Valves	Size	Ø D	Stroke: 20 mm (0.787 in.)				40 mm (1.574 in.)		60 mm (2.362 in.)
			½ in.	¾ in.	1 in.	1½ in.	2 in.	3 in.	4 in.	6 in.
BL Face-to-face dimension according to ASME/ISA 75.08.01 (mm)	Class 150 RF		184	184	184	222	254	298	352	451
	Class 300 RF		190	194	197	235	267	318	368	473
~ H _B for standard bonnet and actuator (mm)	IG 253	265	457	457	457	475	478			
	IG 503	352	577	577	577	602	602	665	668	
	IG 701	390				671	673	737	737	805
~ H _B for extension bonnet and actuator (mm)	IG 253	265	551	551	551	556	559			
	IG 503	352	678	678	678	683	683	772	775	
	IG 701	390				752	754	843	846	978
~ H _B for bellows seal bonnet and actuator (mm)	IG 253	265	610	610	610	615	615			
	IG 503	352	730	730	730	735	735	925	925	
	IG 701	390				775	775	965	965	1235
~ Weight in kg for standard bonnet and actuator	IG 253		19,0	19,0	19,0	29	32			
	IG 503		29	29	29	39	42	66	89	
	IG 701					50	53	77	100	166
~ Weight in kg for extension bonnet and actuator	IG 253		20	20	20	29	32			
	IG 503		30	30	30	39	42	67	90	
	IG 701					51	54	79	102	171
~ Weight in kg for bellows seal bonnet and actuator	IG 253		20	22	22	30	33			
	IG 503		30	32	32	40	43	74	96	
	IG 701					51	54	85	107	180
BL Face-to-face dimension according to ASME/ISA 75.08.01 (in.)	Class 150 RF		7.25	7.25	7.25	8.75	10.00	11.75	13.88	17.75
	Class 300 RF		7.50	7.62	7.75	9.25	10.50	12.50	14.50	18.62
~ H _B for standard bonnet and actuator (in.)	IG 253	10.4	18.0	18.0	18.0	18.7	18.8			
	IG 503	13.9	22.7	22.7	22.7	23.7	23.7	26.2	26.3	
	IG 701	15.4				26.4	26.5	29.0	29.0	31.7
~ H _B for extension bonnet and actuator (in.)	IG 253	10.4	21.7	21.7	21.7	21.9	22.0			
	IG 503	13.9	26.7	26.7	26.7	26.9	26.9	30.4	30.5	
	IG 701	15.4				29.6	27.7	33.2	33.3	38.5
~ H _B for bellows seal bonnet and actuator (in.)	IG 253	10.4	24.0	24.0	24.0	24.2	24.2			
	IG 503	13.9	28.7	28.7	28.7	28.9	28.9	36.4	36.4	
	IG 701	15.4				30.5	30.5	38.0	38.0	48.6
~ Weight in lb for standard bonnet and actuator	IG 253		42.9	42.9	42.9	63.2	70.5			
	IG 503		64.9	64.9	64.9	85.0	92.6	145	195	
	IG 701					110	117	170	221	367
~ Weight in lb for extension bonnet and actuator	IG 253		44.6	44.6	44.6	64.3	71.4			
	IG 503		66.6	66.6	66.6	86.3	93.4	148	199	
	IG 701					112	119	173	224	376
~ Weight in lb for bellows seal bonnet and actuator	IG 253		44.1	48.5	48.5	66.1	72.8			
	IG 503		66.1	70.5	70.5	88.2	94.8	163	212	
	IG 701					112	120	187	235	396

* Nominal sizes only. Contact factory for certified dimensions and weights.

General service control valve – order code

FlowTop	Type							Size	PN	Body Material/Certificate					Plug						Seat	Cv	Trim				
	V750	D	F	V	N	A	2 in			150	A216WCC	N	O	A	O	P	O	N	D	1				M	G	50	55
Valve type	Screwed seat design	V750																									
	Clamped seat design	V752																									
Body design	Globe, Three-Flange design		D																								
Flange connection	Integral Flange / ASME B16.5	Raised Face		F																							
Balancing	Without				V																						
			Buna-N and Filled PTFE	A																							
			Viton and Filled PTFE	B																							
	P/B O-Ring design		Viton and PEEK	C																							
			EPDM and PEEK	D																							
			Kalrez 4079 and Filled PEEK	E																							
	Chemraz 555 and Filled PEEK	F																									
Bonnet	Standard					N																					
	Extended					R																					
	Bellows Seal					B																					
Packing	Braided PTFE - internal					D																					
	Braided PTFE live loaded internal					E																					
	Braided PTFE live loaded internal - Vacuum					C																					
	Braided graphite - internal					T																					
	Braided graphite live loaded internal					R																					
	Lattyflon 3260 LM - live loaded internal - ISO 15848-1					U																					
	Lattygraf 6940 EF - live loaded internal - ISO 15848-1					V																					
	Lattyflon 3260 LM - live loaded external - ISO 15848-1					Q																					
	Supagraf Ctrl - live loaded external - ISO 15848-1					J																					
	Lattyflon 3260 LM - live loaded - ISO 15848-1					Q																					
	SUPAGRAF Ctrl - live loaded - ISO 15848-1					J																					
NPS (Size)	½, ¾, 1, 1½, 2, 3, 4, 6 in.						½ to 6 in.																				
Class	Class 150							150																			
	Class 300							300																			
Body material	Carbon Steel								A216WCC																		
	Stainless Steel								A351CF8M																		
Regulation for material	Without PED	(no option VIL)								N																	
	PED									O																	
	NACE (w/o PED)	(no option VIL)								M																	
	NACE and PED									W																	
Material certificate	Without									O																	
		2.2								Z																	
		3.1 with list of certificates (without CMTR)								B																	
	EN 10204	3.1 with copy of certificate (CMTR of Body+Bonnet)								D																	
		3.1 with copy of certificate (CMTR of Body+Bonnet+Bolting)								E																	
		3.1 with copy of certificates: Code E + Trim								H																	
Regulation for final test	EN 1349 (IEC-534 / FCI 70-2)										A																
		Standard (SIL certificate available)																									
Final test certificate	Without									O																	
		2.2								Z																	
	EN 10204	3.1								B																	
		3.2								S																	
Plug type	Contoured Plug													P													
	Quick Open													T													
	CavStream 1	1-Stage Severe Service Trim												C													
Trim equipment	Without														O												
	MegaStream 1	1-Stage Severe Service Trim													C												
Trim design	Standard															N											
	Tenifer treated															D											
	Seat surface Alloy 6															K											
	Full contour Alloy 6															T											
	Hardened															H											
	Soft seat															W											
Shut-Off Class	Class IV	FCI 70-2 / IEC 60534-4	(Test medium: Air)																		P						
			(Test medium: Water)																			D					
	Class V	FCI 70-2 / IEC 60534-4	(Test medium: Air)																			S					
			(Test medium: Water)																				F				
Class VI	FCI 70-2 / IEC 60534-4	(Test medium: Air)																			T						
Guiding	Post guided/Cage guided with P/B																					1					
Characteristic	Linear																								M		
	Equal Percent																									G	
	Modified Equal Percent																									L	
	On-Off																									A	
Flow direction	Flow to open (Flow Under)																									G	
	Flow to close (Flow Over)																									I	
Seat diameter	[mm]																									8 - 130	
Cv value	[gpm]																									1.16 - 410	
Trim material	316 SS																									316SS	
	1.4122	Depending on body material																								1.4122	
	416 SS																									416SS	
	316L SS																									316L	

Pneumatic multi-spring actuator — FlowAct valve order code

FlowAct				Order Code									
				I	G	503	B	FY	O	Z	B	S	
Actuator design	Internal air supply for yoke code			I									
Yoke design	Multi-function — yoke with SMHW interface				G								
Actuator size (cm ² /in. ²)	250	38.75	Stroke	10, 20	0.39, 0.79		253						
	500	77.50	(mm/in.)	20, 40	0.79, 1.57		503						
	700	108.50		20, 40, 60	0.79, 1.57, 2.36		701						
Color	White, powder coated						B						
Spring range (bar/psi)			Stroke (mm) ¹⁾	Actuator	253	503	701						
	0.2 to 1.0	3 to 15	20, 40, 60	Actuator force (N)	500	1,000	1,400		AD				
	0.5 to 1.9	7 to 28	20, 40, 60		1,250	2,500	3,500		BL				
	1.0 to 2.4	15 to 35	20, 40, 60		2,500	5,000	7,000		DY				
	1.5 to 2.7	22 to 39	20, 40		3,750	7,500	10,500		VC				
	1.5 to 3.8	22 to 55	20, 40, 60		3,750	7,500	10,500		VI				
	1.8 to 2.7	26 to 39	20				12,600		JC				
	2.0 to 4.8	29 to 70	20, 40, 60		5,000	10,000	14,000		FY				
Handwheel	Without								O				
	Top mounted "light design"								L				
	Top mounted "heavy design"								H				
	Side mounted								S				
Stroke limitation	Not adjustable — "bottom"								E				
	Not adjustable — "top"								F				
	"Adjustable"								U				
Handwheel and stroke limitation	Side-mounted handwheel and "adjustable" stroke limitation								A				
	Safety position at air failure	Spring to close									Z		
Spring to open										A			
Fail in place by spring to close										S			
Fail in place by spring to open										T			
Stroke (mm/in.)	20	0.79										A	
	40	1.57										B	
	60	2.36										C	
Temperature range	Standard	-40°C to 80°C (-40°F to 176°F)											S

¹⁾ Not every spring range/stroke combination is possible for each actuator size.

Notes

Notes



Flowserve Corporation
5215 North O'Connor Blvd.
Suite 700
Irving, Texas 75039-5421 USA
Telephone: +1 937 890 5839

VATB000325-00 (EN/A4) May 2022

Flowserve Corporation has established industry leadership in the design and manufacture of its products. When properly selected, this Flowserve product is designed to perform its intended function safely during its useful life. However, the purchaser or user of Flowserve products should be aware that Flowserve products might be used in numerous applications under a wide variety of industrial service conditions. Although Flowserve can provide general guidelines, it cannot provide specific data and warnings for all possible applications. The purchaser/user must therefore assume the ultimate responsibility for the proper sizing and selection, installation, operation, and maintenance of Flowserve products. The purchaser/user should read and understand the Installation Instructions included with the product, and train its employees and contractors in the safe use of Flowserve products in connection with the specific application.

While the information and specifications contained in this literature are believed to be accurate, they are supplied for informative purposes only and should not be considered certified or as a guarantee of satisfactory results by reliance thereon. Nothing contained herein is to be construed as a warranty or guarantee, express or implied, regarding any matter with respect to this product. Because Flowserve is continually improving and upgrading its product design, the specifications, dimensions and information contained herein are subject to change without notice. Should any question arise concerning these provisions, the purchaser/user should contact Flowserve Corporation at any one of its worldwide operations or offices.

©2022 Flowserve Corporation. All rights reserved. This document contains registered and unregistered trademarks of Flowserve Corporation. Other company, product, or service names may be trademarks or service marks of their respective companies.