

A large liquefied natural gas (LNG) tanker ship is shown at sea during sunset or sunrise. The ship's hull is dark, and its deck is white. Several large, white, spherical storage tanks are visible on the deck. The sky is a mix of blue and orange, with some clouds. The water is dark and has some whitecaps.

LIQUEFIED NATURAL GAS

A Complete Flow Control Portfolio to Enable Your Energy Transition Initiatives

VALVE AND AUTOMATION SOLUTIONS



A CLEANER WAY FORWARD

Liquefied natural gas (LNG) will play a pivotal role as companies transition from coal and oil to cleaner energy sources during renewed efforts to significantly reduce the greenhouse gases that contribute to climate change.

Nations as well as businesses are pursuing strategies for decarbonization to limit greenhouse gases. In response, natural gas is emerging as the fossil fuel of choice. Burning it emits up to 50% less carbon dioxide (CO₂) emissions than coal.ⁱ That's the value of natural gas as a primary feedstock for energy production and conversion to hydrogen.

Natural gas also is expected to remain the key backup fuel during intermittent outages that naturally occur with increasingly popular renewable power sources, such as wind and solar.ⁱⁱ

It's no wonder then that LNG is one of the fastest-growing commodities; global demand is expected to rise as much as 50% by 2030.ⁱⁱⁱ

Your partner for end-to-end LNG solutions

There's a new bottom line across industries: the escalating importance of LNG will significantly impact how companies achieve their objectives for sustainability as well as their future profitability.

Flowserve understands these challenges throughout the LNG value chain. And we're prepared to support our customers' energy transition initiatives with the flow control products and services, technology and expertise to provide proven, end-to-end solutions.

A better way to reduce emissions

Burning LNG to generate energy results in fewer emissions of CO₂ compared to the combustion of coal or petroleum products to produce an equal amount of energy.

91+ kg
(200+ lb)

The amount of CO₂ produced
per million British thermal units
(MMBtu) of coal

91+ kg
(160+ lb)

The amount of CO₂ produced
per MMBtu of distillate fuel oil

~53 kg
(~117 lb)

The amount of CO₂ produced
per MMBtu equivalent of
natural gas

Source: U.S. Energy Information Administration, "Natural Gas Explained," December 8, 2021, <https://www.eia.gov/energyexplained/natural-gas/natural-gas-and-the-environment.php> (accessed December 15, 2021).

ONE EXPERT CHOICE TO HELP WITH YOUR LNG PROCESSES

Flowserve is not just an equipment supplier. We're your ideal partner with the right products, engineering prowess, service and expertise to help companies across industries identify opportunities to enhance process efficiency and cost-effectiveness. What's more, Flowserve offers the following unique advantages that can enable your company to achieve its energy transition objectives, including:

- The most **complete portfolio of flow control equipment** designed to work as a system to optimize LNG processes
- An **end-to-end industrial internet of things (IoT) suite** of solutions that can:
 - Increase process and operational efficiency with remote monitoring of assets
 - Utilize predictive analytics to anticipate equipment failures before they happen
 - Enable operators to take preventive measures to avoid process disruptions
- A **single point of contact** for:
 - Project planning with engineering, procurement and construction (EPC) consultants and company project managers
 - Commissioning and operations with plant managers and technicians
- **Unparalleled service and technical support** expertise backed by a global network of Quick Response Centers (QRCs)

The right solutions along the LNG value chain

Designed to meet the latest industry standards for fugitive emissions, Flowserve valves can help companies mitigate emissions throughout the processing, transportation and consumption of LNG.

Here's where emissions typically occur:

Upstream	7 to 19%
Liquefaction	8 to 10%
Shipping	3 to 4%
Regasification	3 to 5%
End-use combustion	67 to 79%

Source: Bloomberg, "Carbon neutral LNG: Suppliers focus on optionality, transparency and CCS," April 19, 2021
<https://www.bloomberg.com/professional/blog/carbon-neutral-lng-suppliers-focus-on-optionality-transparency-and-ccs> (accessed December 15, 2021).

A COMPREHENSIVE FLOW CONTROL PORTFOLIO

Valves and automation engineered to provide end-to-end solutions

Operators can overcome common challenges experienced in LNG processes by investing in the broad range of Flowserve valves, actuators, positioners and other automation, as well as IoT remote monitoring, asset control and predictive analytics solutions. They're designed to work together as a complete flow control system that can enable companies to:

- Achieve **maximum productivity** while reducing the risk of surges in LNG compressor applications that cause unplanned downtime
- Deliver exceptionally **fast stroke speed** while also **precisely controlling valves** with intelligent positioners
- Accomplish **commissioning and tuning in minutes** with one-button set-up
- Ensure **reliable performance** in harsh environments with equipment designs that eliminate complexity
- **Minimize emitted noise and vibration** that can cause equipment wear or damage
- **Simplify maintenance** and upgrades
- Meet environmental standards and **ensure fugitive emissions compliance**, regardless of how extreme the conditions

Complete system expertise: Pumps and seals

Enhance performance, optimize efficiency, and minimize leakage

We understand how pumps and seals should work in complete systems throughout the entire LNG value chain. As a result, Flowserve can help you engineer, design, commission and maintain end-to-end solutions so they perform optimally.

Inferior or poorly specified pumps and seals in critical LNG applications can leak and put your operations at risk. The potential harm to personnel, environmental contamination and product loss can disrupt processes, jeopardize achievement of business objectives, and expose your company to regulatory penalties.

Flowserve offers a broad portfolio of pumps and seals so you can safeguard against leakage, fugitive emissions and product loss.

TECHNICAL SUPPORT AND SERVICES

Detect, diagnose and quickly respond to equipment and system issues

Successful LNG companies will need more than engineered-to-order systems. In addition to providing the industry's most complete flow control solutions portfolio, Flowserve introduced RedRaven, an end-to-end IoT solution encompassing sensors to cloud architecture, condition monitoring and predictive analytics services.

LNG operators can use RedRaven to monitor thousands of assets over sprawling facilities reliably and cost-effectively. With real-time RedRaven monitoring, plant personnel and Flowserve technicians can view aggregated data to make decisions on-site. Our monitoring center along with our team of service and support personnel can provide you with valve insights, alerts and recommendations.



More services to optimize your LNG value chain

Flowserve offers a global network of Quick Response Centers (QRCs) plus a broad range of services across the LNG value chain — from upstream supply, liquefaction and production to shipping, regasification and downstream use.

These include:

- Sizing and selection of valves
- Startup optimization and performance testing
- Leak detection
- Control, isolation, calibration and repair of pressure-relief valves
- Configuration and repair of regulators
- Shutdown, turnaround and outage planning and execution support
- Technological upgrades and retrofits
- Online and offline performance monitoring and IoT system analytics
- Training for products and systems

SUPERIOR SOLUTIONS THROUGHOUT THE LNG VALUE CHAIN

Speed and reliability are critical to your ability to meet ever-increasing demand for LNG. Ensure high flow rates and precision control – while also meeting all contracted quality requirements – with valves, actuators, seals and other proven gas handling solutions from Flowserve that are ideal for each step in your LNG production.

Inlet facilities and acid gas removal (AGRU)

Remove acid gas/Hg from the feed gas in order to meet LNG specifications and prevent freezing in the cryogenic sections of the plant. The acid gas components are predominantly CO₂ with trace quantities of hydrogen sulfide (H₂S) and other sulfur species.

- Eliminate contaminants to contracted levels.
- Ensure uptime and avoid damaging downstream cryogenic equipment.
- Maintain permitted emissions levels.

Dehydration

Located downstream of the AGRU. The amine solution of the AGRU saturates the feed gas with water, which is removed in the dehydration unit.

- Increase throughput and uptime.
- Ensure safety and protect gas handling equipment.
- Enhance energy efficiency.

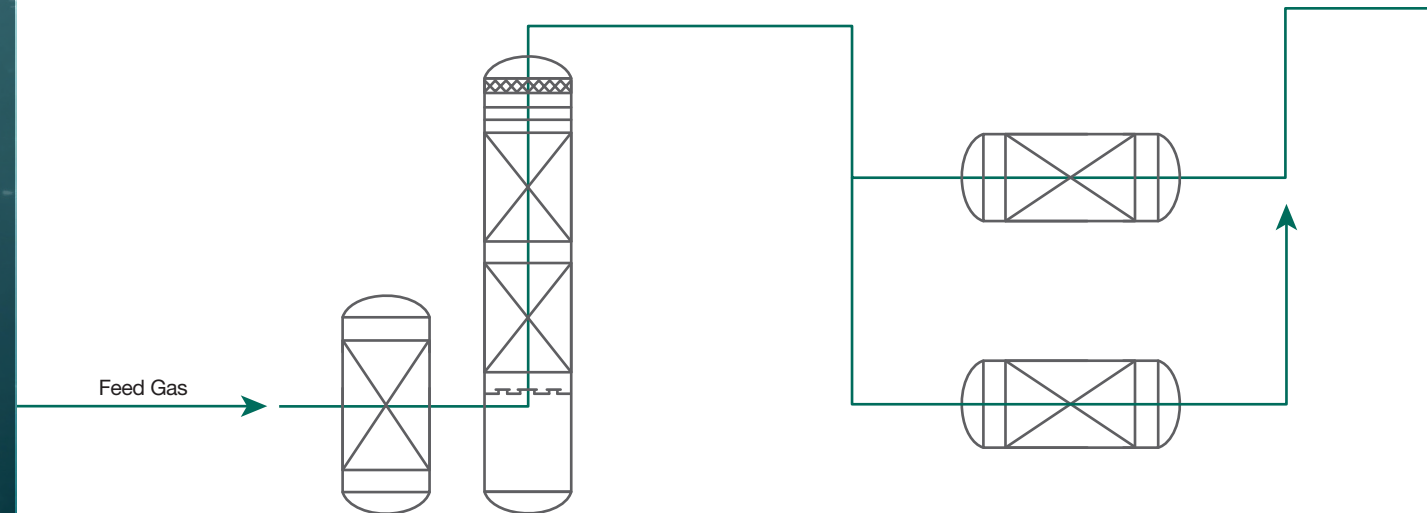

NGL extraction

An NGL/heavies removal unit removes sufficient C5 and heavier components (including freeze components) from the natural gas, leaving the dehydration unit to meet the LNG product specification and avoid the potential for condensation or freezing of these components in the downstream liquefaction and refrigeration unit. The extracted heavy hydrocarbons are processed in the stabilizer to meet the required condensate specification and then routed to condensate storage.

- Maximize recovery of heavy hydrocarbons for resale or use as refrigerants in subsequent LNG processes.
- Meet condensate specifications.
- Avoid freezing in downstream liquefaction and refrigeration processes.

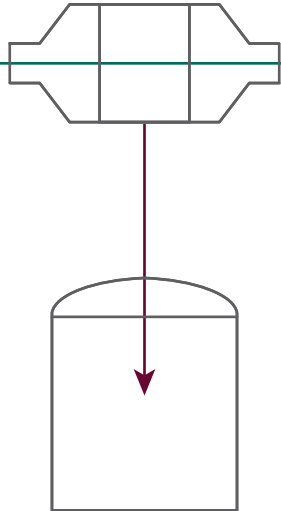

Condensate storage and loading

Store heavy hydrocarbon components separated during LNG processes for resale as feedstock for petrochemical production and as fuel for vehicles, heating and cooking.

- Reliably control high flow rates of condensates.
- Minimize fugitive emissions with valve packing during loading into tanks and for shipment.
- Comply with fire, safety and explosion-proof standards.

Liquefaction and refrigeration

Produce LNG at -162°C (-260°F) by removing heat from dry, treated feed gas arriving from the NGL/heavies removal unit.

The liquefaction process is the propane pre-cooled mixed refrigerant process. The treated natural gas stream from the NGL/HRU is pre-cooled by propane vaporizers before entering the main cryogenic heat exchanger, where the gas is liquefied and sub-cooled by mixed refrigerant (MR). The LNG stream leaving the main cryogenic heat exchanger is let down in pressure across a hydraulic turbine and routed to storage.

- Valves, automation, compressor and pump seals, and pumps must perform reliably at cryogenic ranges.
- Protect compressors from catastrophic surge damage.
- Ensure precision control and high flow rates.

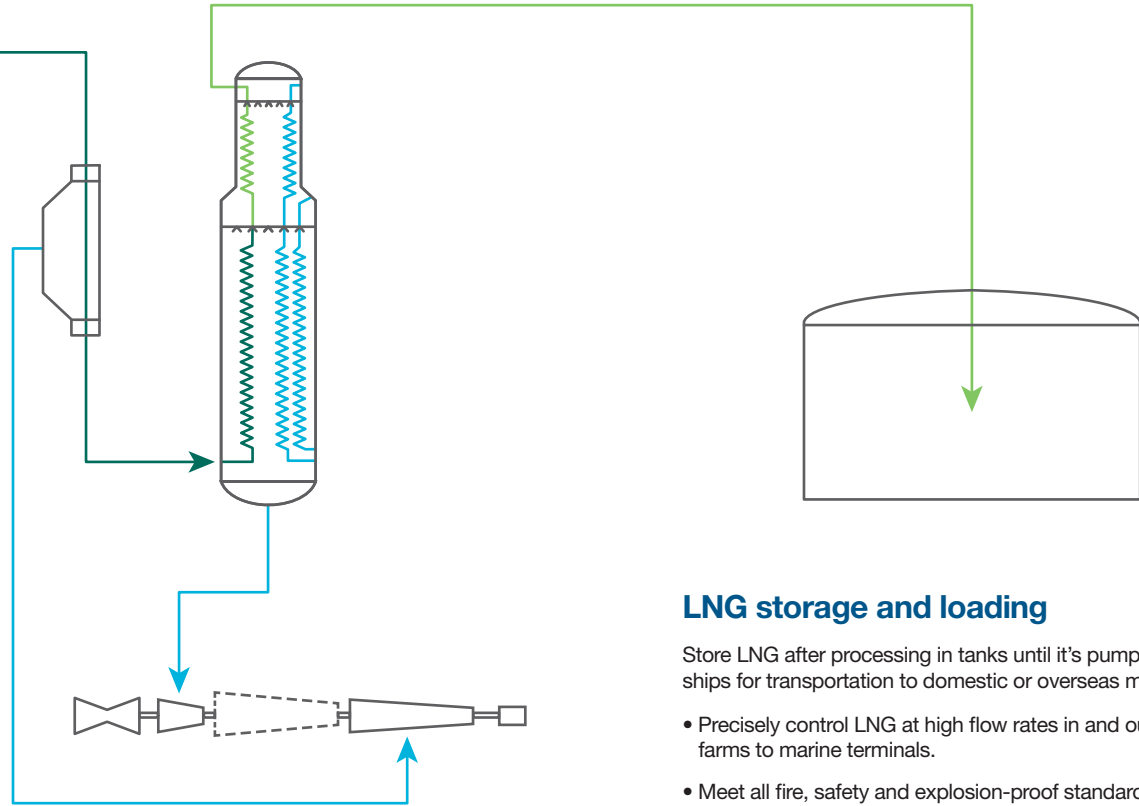

LNG storage and loading

Store LNG after processing in tanks until it's pumped aboard ships for transportation to domestic or overseas markets.

- Precisely control LNG at high flow rates in and out of tank farms to marine terminals.
- Meet all fire, safety and explosion-proof standards.
- Minimize leakage and recover boil-off gas (BOG) vapors.

Cut Emissions With Zero Leakage Shutoff

Highly reliable TX3 butterfly valve design ensures compliance

Meeting fugitive emissions standards plus fire-safe design and anti-blowout requirements are top priorities for LNG operators. TX3 butterfly valves offer excellent shutoff capabilities to ensure safety and compliance in the most demanding applications.

The precision seat and seal are machined at an offset angle, creating even seat loading around the entire seat ring and eliminating rubbing between the seat and seal during opening and throttling. Combined with a laminated seat ring, the TX3 valve's triple offset design provides long-lasting, bi-directional, bubble-tight shutoff, even in gas applications.



Advantages and benefits

- **Higher reliability** — API 598 zero-leakage shutoff assured by triple offset design and laminated metal graphite seat seal.
- **Extended service life** — Low-operating torque results from the low-friction, low-wear elliptical sealing surfaces.
- **Minimized emissions** — Packing options meet stringent ISO 15848-1 fugitive emissions requirements.
- **Improved safety** — API 607 fire-safe design plus API 609 anti-blowout shaft

Durco® TX3 triple offset butterfly valve



Eliminate leaks — even in gas service — with this manual or automated isolation valve boasting bi-directional, bubble-tight shutoff per API 598.

- Assure environmental compliance with packing options that meet ISO 15848-1 fugitive emissions requirements.
- Improve safety with API 607 fire-safe design plus API 609/ASME B16.34 anti-blowout shaft.
- Eliminate wear from sealing surface contact and maintain sealing integrity during high-cycle operation with triple offset design.

Valtek® TX3 triple offset butterfly control valve



Realize precision control with this automated valve package that provides API 598 zero-leakage shutoff along with long-lasting, reliable performance.

- Extend service life and minimize actuation costs with low-operating torque arising from low-friction, low-wear elliptical sealing surfaces.
- Meet industry safety standards with API 607 fire-safe design plus API 609/ASME B16.34 anti-blowout shaft.
- Minimize fugitive emissions with packing options that meet ISO 15848-1 requirements.

Valtek Valdisk™ high-performance butterfly valve

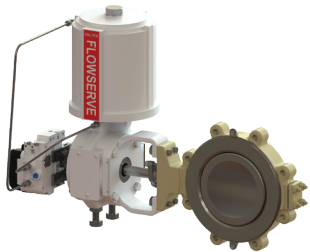

Ensure high-capacity performance with bi-directional Class IV or VI shutoff and low pressure loss with this cost-effective valve package.

- Get unmatched performance, even in large pressure drops, owing to high-thrust cylinder actuator and eccentric-cammed disc.
- Ensure greater throttling accuracy with low breakout torque provided by jam-lever toggle seating.
- Improve uptime and reduce maintenance costs with double offset design that minimizes wear and leakage.

Durco Big Max BX2001 double offset butterfly valve



Achieve reliable on-off performance with this cost-effective, all-purpose valve package featuring a compact valve design and energy-efficient actuator.

- Reduce fugitive emissions through triple-leak protection of primary stem seal plus two optional secondary seals.
- Increase capacity and improve flow control with low-profile, double-offset disc.
- Increase personnel and plant safety with anti-blowout protection per API 609.

Advanced Trim Minimizes Noise and Vibration



Proven technologies for LNG's most challenging applications

Industry-leading, noise-abatement and anti-cavitation trims available for Valtek globe valves can ensure LNG operators minimize — if not eliminate — control valve noise and vibration.

Applied technologies significantly reduce noise 30 to 40 dBA through staging, frequency shifting, phase cancelation, velocity control and our patented WaveCracker technology. In the most challenging LNG applications, staged pressure drops eliminate cavitation.

Advantages and benefits

Meet your exact trim requirements — Wide variety of anti-cavitation and noise reduction trims expands the service usability across a broad range of LNG applications, including cryogenic:

- Standard full-area trim provides maximum Cv.
- Reduced trim is available when lower Cv values and large body expansions are required.
- Custom-engineered trims are tailored to exact process conditions.

Valtek Mark One™ globe control valve



Ensure superior control and throttling performance in liquid or gaseous service with this versatile and easy-to-maintain automated valve package.

- Get position accuracy, repeatability and faithful response with digital positioner and stiff, high-thrust, double-acting piston cylinder actuator.
- Lower installation and maintenance costs with a compact package featuring top-entry, clamped-in, self-aligning seat and trim.
- Application flexibility provided by numerous severe service trim options; cryogenic configuration available.

Valtek Mark 100 high-capacity control valve

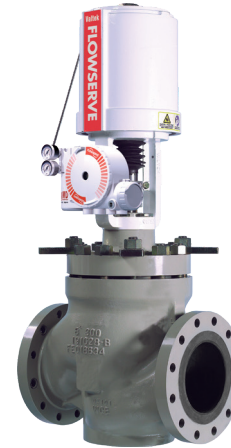

Achieve extra-fine process control in high-capacity liquid or gaseous applications with this cost-effective automated valve.

- Lower initial costs with a higher-capacity design that enables more cost-effective valve sizes to be used.
- Get precision control with longer-than-typical stroke lengths combined with double top stem and cage guiding.
- Accomplish reliability, accessibility and maintainability (RAM) goals with a clamped-in, self-aligning seat and top-entry trim.

Valtek DiamondBack™ cavitation elimination trim

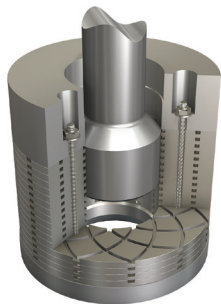

Eliminate cavitation in even the most challenging liquid applications with the most advanced anti-cavitation trim design in the industry.

- Prevent cavitation from forming and minimize hydrodynamic noise using staged pressure drops resistant to erosion and plugging.
- Customize trim to application requirements; available in a wide range of materials.
- Simplify maintenance with easy-to-clean stacked disc design.

Valtek MegaStream™ noise reduction trim



Effectively reduce control valve noise and vibration in a wide range of gas applications through staging, frequency shifting, attenuation and velocity control.

- Achieve noise attenuation up to 30 dBA, improving the safety of personnel.
- Extend valve and system life by reducing downstream noise and acoustic-induced vibration (AIV) and flow-induced vibration (FIV) fatigue failure.
- Realize cost-effective, reliable and long-lasting performance derived from heavy-duty, nested cylinder design.



Revolutionary LNG Anti-Surge Control With Unprecedented Speed

Increase productivity without damaging compressors

Protect compressors in LNG processes from catastrophic surge damage by providing exceptional response for driving the compressor valve open when needed and in a steady-state position when recycling. This enables operators to run compressors near

the surge line for increased productivity in the most challenging applications, including natural gas liquefaction.

In addition, Valtek compressor anti-surge valves are easy to calibrate; one-button configuration simplifies set-up and tuning.

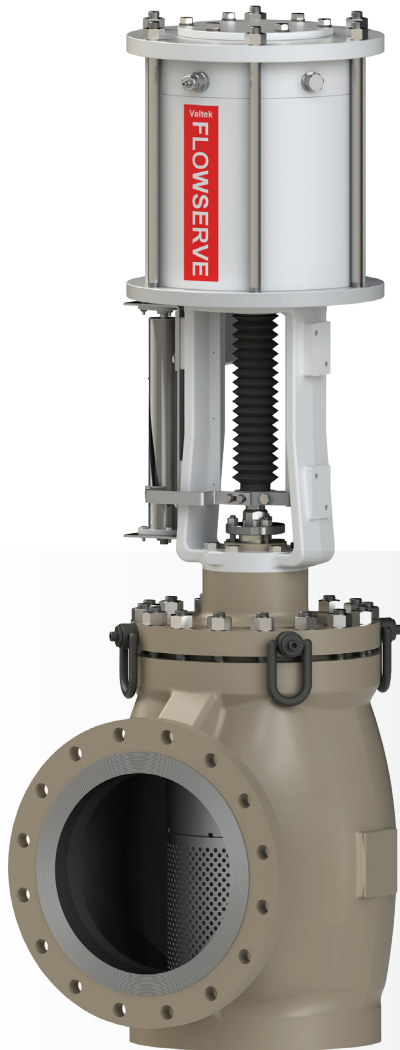

Valtek compressor anti-surge valve

Protect compressors from catastrophic damage with a revolutionary anti-surge solution that delivers unprecedented control *and* exceptional responsiveness in a reliable and easy-to-use package.

- Overcome the conflict between precision and speed without compromise by replacing volume boosters with the advanced Logix 3800JF positioner.
- Set up and tune the valve package in minutes instead of hours with one-button configuration.
- Ensure high-capacity performance with an angle body valve that has 51 to 248% greater capacity compared to similar offerings.
- Extend service life and reduce system wear with advanced trims that deliver high flow rates while reducing noise and vibration.

Advantages and benefits

- **Precision control and fast stroke speeds** — Provide both small step changes and high flow when required; the control valve system includes the JetFlow relay integrated with a Logix 3800JF intelligent positioner, which overcomes the conflict between precision and speed.
- **Eliminate auxiliary accessories** — The Logix 3800JF positioner reduces complexity, so there's no need for volume boosters. The system is tuned in minutes with a single button push.
- **Keep noise and vibration low** — Advanced trims, such as MegaStream and Stealth, provide industry-leading flow rates while keeping emitted noise and resulting vibration levels low, limiting system wear or damage and minimizing maintenance labor and costs.



Avoid Downtime While Also Ensuring Compliance

Meet fugitive emissions compliance across LNG applications

LNG operators must keep environmental regulations for fugitive emissions in mind, especially in applications with high pressures and valve operational cycles.

The ability of a valve to contain fluids not only reduces environmental damage but also minimizes financial losses to the operator. When a valve seal or stem packing fails to prevent fugitive emissions, LNG operators can face significant costs due to unplanned downtime and repairs along with potential legal repercussions for environmental damage. In applications across the LNG value chain, we provide proven equipment and integrated solutions that enable LNG operators to ensure compliance with emissions standards.

Advantages and benefits

- **Get leak-tight closure** under all operating conditions with self-adjusting seat designs.
- **Ensure compliance** with fugitive emissions standards, including ISO 15848, API 622 (packing), API 624 (rising stem) and API 641 (quarter-turn).
- **Improve process integrity** through performance stability and longevity by the use of high-strength materials, customized seat options and multiple pack offerings.
- **Lower maintenance costs and improved equipment lifespan** are realized by designs that allow for thermal expansion at high/low pressures, thereby minimizing contact between pressure-loaded parts and ensuring extended seat life and sealing capability.

Valbart® TMCBV side-entry, trunnion-mounted control ball valve



Manage high pressures while minimizing operating torque with this compact, cost-effective valve that merges trunnion-guided design with characterized control and advanced trims.

- Ensure Class IV or V shutoff at any pressure with spring-loaded, process energized seats.
- Secure savings by using a smaller valve with greater capacity and rangeability than alternative globe valves.
- Use industry-proven technologies for cavitation control and noise attenuation.

Valbart RSBV rising stem ball valve



Maximize service life in high-cycle applications with this rising stem ball valve that provides friction-free, linear stem operation for optimal actuation.

- Reduce wear with helix coil stem design that actuates the valve without rotation.
- Prevent losses from process contamination or material leakage with mechanically energized metal or soft seat.
- Ensure process integrity with tightness performance up to ASME FCI-70-2 Class VI.

Valbart VB2 side-entry, trunnion-mounted ball valve



Get API 6D and 6A compliance along with double block and bleed (DBB) capability; cryogenic configuration available.

- Assure bi-directional sealing with two independent floating seats.
- Reduce actuation costs with seat design that minimizes the valve's operating torque without losing sealing power.
- Ensure compliance with ISO 15848 fugitive emissions standard and improve safety with anti-blowout stem.

Valbart VT1 top-entry, trunnion-mounted ball valve



Lower maintenance and actuation costs with this in-line repairable valve that minimizes operating torque without losing sealing power; cryogenic configuration available.

- Achieve API 6D and 6A compliance along with double block and bleed (DBB) capability.
- Assure bi-directional sealing with two independent floating seats.
- Enhance safety with anti-blowout stem while also ensuring ISO 15848 fugitive emissions compliance.



McCANNA™ McCannaSeal top-entry ball valve

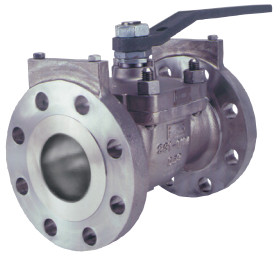

Ensure cost-effective, low-torque operation with this metal- or soft-seated floating ball valve.

- Get up to leak-tight closure under all operating conditions with self-adjusting, wedge-seat design.
- Comply with environmental standards with stem seal design that meets ISO 15848 requirements and prevents stem blowout.
- Simplify maintenance with top-entry design that permits in-line service and emergency access in minutes.

Worcester® 829 two-piece, full port flanged ball valve



Realize trouble-free operation and lower cost of ownership with this compact, ASME B16.34 compliant valve.

- Gain process flexibility from valve design that provides bubble-tight shutoff with bi-directional flow.
- Reduce space and cost requirements with low operating torque that enables use of compact actuation.
- Meet ISO 15848 fugitive emission requirements with fire-rated graphite gland packing and PTFE-coated graphite body seals.

Worcester C44 cryogenic ball valve



Provide reliable shutoff in intermittent or continuous cryogenic applications down to -254°C (-425°F) with this three-piece, flanged ball valve specifically designed for liquefied gases.

- Maintain safety with fire-tight configuration, blowout-proof stem and an overpressure-relief ball design.
- Ensure tight shutoff with zero body leakage and low torque through thermal excursions with Polyfill® seats and body seals and Belleville live-loaded TFE packing rings.

Valtek MaxFlo® 4 eccentric rotary plug control valve



Attain higher rangeability and capacity plus precise control with this cost-competitive general service valve.

- Use smaller, more cost-effective valves with high Cv design — up to 70% greater per size.
- Substantially improve control and service life with robust polygon shaft/plug and splined actuator connection.
- Ensure Class IV (metal seat) or VI (soft seat) shutoff with double-offset, eccentric plug design that reduces seat wear.



Anticipate Issues With Advanced IoT Diagnostics

Next-generation positioner predicts action that safely maintains LNG production

The Logix 3800 digital positioner coupled with any one of a variety of precision actuators enables improvements in LNG process uptime, reliability and throughput. Advanced diagnostics not only identify developing problems in the control valves, but also help guide corrective actions to ensure reduced return-to operation times.

The next-generation actuation equipment is enabled for the internet of things (IoT), offering embedded measurement, data reduction and diagnostic functionalities. Its user interface (UI) facilitates easy configuration, operation and system diagnostics within a single view.

Advantages and benefits

- **Anticipate and avoid issues** — Powered by ValveSight DTM, the Logix 3800 positioner has five onboard pressure sensors that enable LNG operators to identify and assess the severity of developing problems so action can be taken before a critical event.
- **Trouble-free performance** — Reliable uptime in demanding LNG applications is ensured by the shielded, dual-element, non-contact, magneto-resistive position sensor and temperature-compensated, dual-poppet pneumatic relay.
- **Easy configuration and calibration** — One-button setup automatically configures the zero, span and gain of the positioner for most valves in less than 60 seconds.
- **Enhance safety** — Non-incendive and explosion-proof design from -52°C to 185°C (-62°F to 365°F) ensures reliable operation in hazardous conditions. Meets SIL 3 safety integrity standards; certified for use in explosion-proof Exd IIC hazardous locations.

Logix 3800 digital positioner



Maximize production and reduce operating costs with this next-generation smart positioner.

- Minimize downtime with predictive diagnostics that help identify field problems and expedite corrective actions.
- Simplify setup with quick-calibration button that automatically configures the zero, span and gain in less than 60 seconds.
- Get application flexibility due to compatibility with all standard communication protocols as well as linear and rotary applications.

Limitorque® LRP rack and pinion actuator



Ensure high performance in quarter-turn applications with this balanced double rack and pinion pneumatic actuator.

- Improve service life and performance stability with support rod design that makes sure side loads are transmitted through the bearings, not the body.
- Match torque requirements precisely, owing to linear torque curve and large range of sizes.
- Simplify installation with ISO 5211 and NAMUR VDI/VDE 3845 mounting patterns.

Limitorque LPS Scotch yoke actuator



Reliably automate on/off, inching and modulating applications using medium to large quarter-turn valves.

- Ensure regulatory compliance with the highest industry standards, including EN 15714 and IEC 61508; SIL 3 capable.
- Lower ownership costs with 25-year design life and maintenance intervals up to six years.
- Reduce maintenance costs with modular construction that enables on-site service without special tools and removal from the valve.

Limitorque LPC compact Scotch yoke actuator

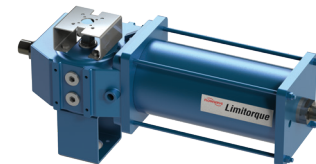

Take advantage of this compact pneumatic actuator in on-off, light modulating and control applications of small or medium quarter-turn valves.

- Reduce ownership costs with 25-year lifecycle and maintenance intervals up to five years (or EN 15714 endurance testing).
- Get superior reliability and durability with heavy-duty design and excellent corrosion resistance.
- Ensure regulatory compliance, including EN 15714 and ISO 9001; SIL 3 capable.



Automate to Optimize LNG Process Performance

The right controls for every valve upstream, midstream and downstream

Invest in valve automation that dramatically improves the control, precision and efficiency of processes throughout the LNG value chain.

Valtek rotary and linear double-acting piston cylinder actuators provide superior resistance to dynamic fluid forces acting on the valve trim compared to diaphragm actuators. Valtek piston cylinder actuators enable control valves to reliably regulate constantly fluctuating flows by providing the pneumatic stiffness required to minimize these fluctuations. And Flowserve also provides all of the gearing your actuation equipment requires.

Advantages and benefits

- **Ensure precise control** — Achieve excellent throttling performance and increase efficiency with high torque and pneumatic stiffness.
- **Avoid unplanned downtime** — Low-friction bearings provide millions of cycles with minimal wear to reduce maintenance and lower the total cost of ownership.
- **Simplify installation and maintenance** — Actuator design provides easy access to internal components with a compact, lightweight footprint available in some models.



Valtek VR rotary cylinder actuator

Ensure excellent throttling performance with high torque and pneumatic stiffness with this compact, double-acting piston cylinder actuator.

- Achieve precise control and eliminate backlash with rocking piston and splined shaft connections.
- Get long service life with low-friction bearings that provide millions of cycles with minimal wear.
- Eliminate the need for a pressure regulator with capability to handle supply air pressures to 150 psi (10.3 bar).



Valtek VL linear cylinder actuator

Realize solid throttling or on-off operation for linear control valves with this compact, high-performance, double-acting, piston cylinder actuator.

- Increase efficiency and achieve tighter valve shutoff with substantially higher thrust capability compared to diaphragm actuators.
- Simplify maintenance with cylinder design that provides easy access to all internal components.
- Achieve superior process control with longer stroke lengths and lower air consumption than comparable diaphragm actuators.



Valtek VL-ES external spring linear cylinder actuator

Ensure precise control in applications where longer strokes or unusually high spring thrust is required.

- Get exceptionally stiff performance with minimal air volumes, stronger springs, plug stem jam nut and thrust bearings that prevent windup.
- Simplify installation and maintenance with compact, lightweight design that requires the removal of just two parts to access internals.





Norbro™ 40R rack and pinion actuator

Ensure accuracy and reliability in quarter-turn applications with this double-acting or spring-return actuator.

- Improve control, minimize wear, and extend service life with unique moving guide rod design that limits travel in both stroke directions while eliminating the need for the body to be used as a bearing surface.
- Get application versatility with multi-spring design that provides variable torque/air requirements.



Automax™ Supernova rack and pinion actuator

Get precision and trouble-free operation in quarter-turn applications with this rugged, compact actuator designed for double-acting or spring-return operation.

- Achieve greater control and reliability with integral travel stops in both stroke directions, plus 10 degrees of overtravel for precise adjustment.
- Maximize service life with rugged construction that includes precision-extruded, hard-anodized aluminum body and a one-piece, factory-lubricated, nitride-protected pinion gear.



Limitorque QX non-intrusive electric actuator

Get precision automation of quarter-turn multiport and control valves with this smart actuator that features 100% solid state controls; suitable down to -55°C (-67°F).

- Assure greater process control and position sensing with battery-free, non-contacting absolute encoders.
- Enhance safety and reduce downtime through improved diagnostics, built-in self-test (BIST) features and LimiGard™ fault protection.
- Simplify commissioning with flexible control configurations, setup and diagnostics in 11 languages.



Make energy transition a reality with a complete solutions partner

Unabated consumption of fossil fuels is not a long-term answer to climate change. However, LNG can replace dirtier coal and oil as an energy source and primary feedstock for conversion to hydrogen. Making the switch can deliver significant greenhouse gas reductions and air quality benefits.

Look to Flowserve to enable you to meet these challenges. We are an experienced collaboration partner with a broad product offering for applications throughout the LNG value chain. That makes us the ideal choice to help your company solve its most complex flow control challenges.

We've done it successfully in a variety of industries for more than 225 years. Today, Flowserve is uniquely positioned to leverage our engineering expertise and proven valves, actuators and positioners to provide the end-to-end solutions you'll need across the LNG value chain.

As your partner, we can help you make the right investments that will enable you to shrink your company's carbon footprint and support your organization's overall energy transition initiatives.

SOURCES

¹ Jude Clemente, "Our Climate Fight Begins With Exporting U.S. Natural Gas To Displace Coal," Forbes, November 21, 2021, <https://www.forbes.com/sites/judeclemente/2021/11/21/the-climate-fight-begins-with-exporting-us-natural-gas-to-displace-coal/?sh=7705aff75b17> (accessed December 15, 2021).

² Jude Clemente, "Our Climate Fight Begins With Exporting U.S. Natural Gas To Displace Coal," Forbes, November 21, 2021, <https://www.forbes.com/sites/judeclemente/2021/11/21/the-climate-fight-begins-with-exporting-us-natural-gas-to-displace-coal/?sh=7705aff75b17> (accessed December 15, 2021).

³ Jude Clemente, "Our Climate Fight Begins With Exporting U.S. Natural Gas To Displace Coal," Forbes, November 21, 2021, <https://www.forbes.com/sites/judeclemente/2021/11/21/the-climate-fight-begins-with-exporting-us-natural-gas-to-displace-coal/?sh=7705aff75b17> (accessed December 15, 2021).

⁴ IEA, "The Role of Gas in Today's Energy Transitions," July 2019, <https://www.iea.org/reports/the-role-of-gas-in-todays-energy-transitions> (accessed December 15, 2021).

⁵ IEA, "The Role of Gas in Today's Energy Transitions," July 2019, <https://www.iea.org/reports/the-role-of-gas-in-todays-energy-transitions> (accessed December 15, 2021).

Flowserve Corporation
5215 North O'Connor Blvd.
Suite 700
Irving, Texas 75039-5421 USA
Telephone: +1-937-890-5839

Flowserve Corporation has established industry leadership in the design and manufacture of its products. When properly selected, this Flowserve product is designed to perform its intended function safely during its useful life. However, the purchaser or user of Flowserve products should be aware that Flowserve products might be used in numerous applications under a wide variety of industrial service conditions. Although Flowserve can provide general guidelines, it cannot provide specific data and warnings for all possible applications. The purchaser/user must therefore assume the ultimate responsibility for the proper sizing and selection, installation, operation, and maintenance of Flowserve products. The purchaser/user should read and understand the Installation Instructions included with the product, and train its employees and contractors in the safe use of Flowserve products in connection with the specific application.

While the information and specifications contained in this literature are believed to be accurate, they are supplied for informative purposes only and should not be considered certified or as a guarantee of satisfactory results by reliance thereon. Nothing contained herein is to be construed as a warranty or guarantee, express or implied, regarding any matter with respect to this product. Because Flowserve is continually improving and upgrading its product design, the specifications, dimensions and information contained herein are subject to change without notice. Should any question arise concerning these provisions, the purchaser/user should contact Flowserve Corporation at any one of its worldwide operations or offices.

©2022 Flowserve Corporation. All rights reserved. This document contains registered and unregistered trademarks of Flowserve Corporation. Other company, product, or service names may be trademarks or service marks of their respective companies.