



USER INSTRUCTIONS

Installation
Operation
Maintenance

682R Reservoir API 682 Compliant Reservoirs



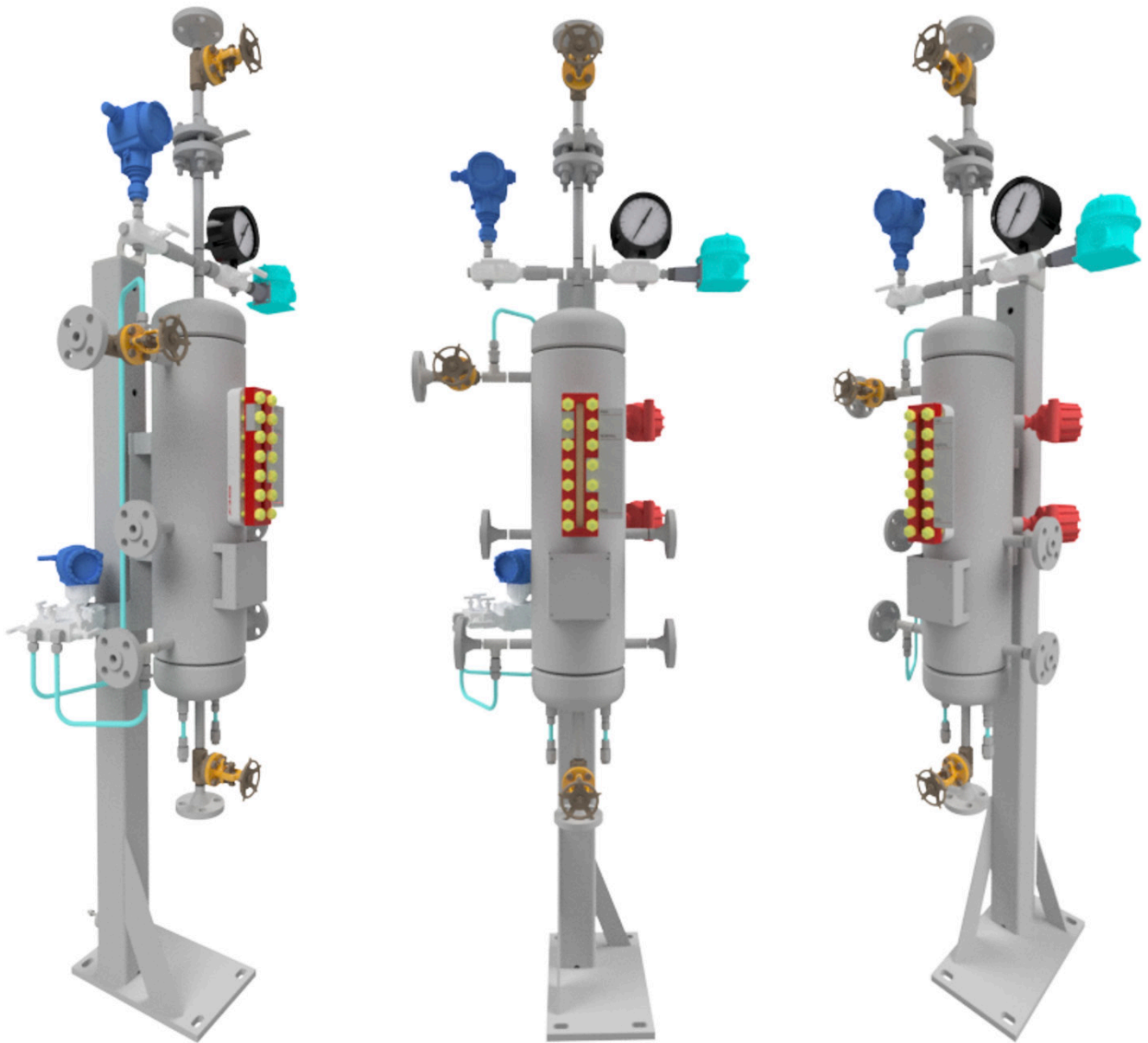

CONTENTS

1	Introduction	4
1.1	About this manual	4
1.2	How to use this manual	4
1.3	Other supplied documents	4
1.4	Conformity with standards and directives	4
1.5	Use of alerts and icons	5
2	Safety	6
2.1	Types of hazardous exposures	6
2.2	General safety	6
2.3	Trained and qualified personnel	6
2.4	Personal protective equipment (PPE)	7
2.5	Actions in extreme conditions	7
3	Environmental Considerations	8
3.1	Disposing of waste products	8
3.2	End-of-life equipment	8
4	Description	9
4.1	Product purpose	9
4.2	Mechanical seal arrangements	10
4.3	Design features	12
5	Preservation, Packing, Transport and Storage Requirements	13
5.1	Mechanical preservation instructions	13
5.1.1	Preservation	13
5.1.2	De-preservation	13
5.2	Packing	13
5.3	Transportation and storage requirements	14
6	Installation	15
6.1	Introduction	15
6.2	Safety considerations	15
6.3	Installation requirements	15
6.4	Product set-up	16
6.4.1	Mounting	16
6.4.2	Connections	17
6.4.3	Interconnecting piping	17
6.5	Installation procedure	18
6.6	Transmitter and switch alarm set points	18
7	Operation	19
7.1	Start-up	19
7.2	Product monitoring	19
7.3	Shut down product	20
8	Maintenance	21
8.1	General guidelines	21
8.2	Periodic maintenance tables	21
8.3	Inspection procedure	22
9	Troubleshooting	23
	ANNEX I	24
	ANNEX II	25

1 Introduction

1.1 About this manual

This manual (which is intended for operating, maintenance, and supervisory personnel) provides information on installing, operating, and maintaining the 682R Reservoir.

Installation in accordance with the following instructions will contribute to long and trouble-free operation of the assembly.

1.2 How to use this manual

Before using this manual, make sure you have fully read and understood the safety section, which can be found in chapter 2. When being new to the 682R Reservoir, pay attention to section 4, which describes the 682R Reservoir in detail.

Only trained and qualified personnel should operate the Reservoir. Refer to section 2.3. Inexperienced personnel should work on this system under the supervision of qualified personnel.

When maintaining the Reservoir, always make sure maintenance procedures are followed. Pay particular attention to the alerts and icons.

The 682R Reservoir shall be used for as described in this manual. Discuss with Flowserve if adjustments beyond its regular use are required.

Changes, modifications, repairs or use under conditions deviating from the design specifications without prior permission of Flowserve can invalidate the product certification, declaration of conformity and/or nameplate.

NOTE: As hazardous conditions can result from planned as well as unforeseen circumstances, pressurized equipment shall always be operated with caution, per site and local policies.

Before installation, equipment should always be fully inspected including, but not limited to:

- Any possible damage due to transport or storage
- Cleanliness required before operation
- Existence of an affixed nameplate with correct inspection markings and design/test conditions

1.3 Other supplied documents

Annex II contains the assembly drawing and sub-component manuals.

1.4 Conformity with standards and directives

The 682R Reservoir conforms to the following standards and directives:

- ASME BPVC Section VIII Div. 1
- Pressure Equipment Directive (PED) 2014/68/EU
- Pressure Equipment (Safety) Regulations (PESR) 2016 (UKCA)
- CSA B51

1.5 Use of alerts and icons

This manual uses “Notes”, “Cautions” “Warnings” and “Dangers” to alert you of important information and/or hazardous situations.

NOTE: “Notes” inform you of important additional information.

 **CAUTION:** *The equipment, product or surrounding area can be damaged if the “caution” is not obeyed.*

 **WARNING:** *Personnel can be (seriously) injured, or the equipment can be seriously damaged if the “warning” is not obeyed.*

 **DANGER:** *Personnel can be (seriously) injured if the “danger” sign is not obeyed.*

The above icons are the general icons that are used for “Cautions”, “Warnings” and “Dangers”. More specific icons are also used, depending on the type of hazard. All icons used in this manual are listed below:

 **WARNING – HIGH PRESSURE:** *Take caution when de-pressurizing the 682R Reservoir. The 682R Reservoir might have energy stored inside. Make sure that de-pressurizing happens slowly.*

 **WARNING – HOT SURFACES:** *The 682R Reservoir and surrounding surfaces might be hot. Take care when touching components. Wear the appropriate Personal Protection Equipment (PPE), according to plant regulations.*

 **WARNING – HAZARDOUS CHEMICALS:** *Dangerous chemical might be released during removal of the 682R Reservoir. Wear Personal Protective Equipment (PPE). Follow all safety regulations and Plant regulations.*

2 Safety

2.1 Types of hazardous exposures

The following hazards can be present in the system:

- High pressure
- Dangerous or toxic chemicals
- Temperature (hot or cold surfaces)
- Dangerous moving parts (during installation or maintenance)
- Electrical hazards

If the 682R Reservoir has any external leaks, the process in which the Reservoir is used should be stopped immediately and have the leak repaired by qualified personnel. When extreme conditions occur, and the possibility of a failure is imminent, plant and end-user safety regulations shall be followed.

2.2 General safety

When installing, operating and maintaining the 682R Reservoir, pay attention to safety:

- Obey all applicable safety laws and regulations
- Obey all plant regulations
- Make sure that only trained and qualified personnel work on it. Refer to section 2.3
- Read and understand each part of this manual
- Follow the installation, operation, and maintenance procedures
- Wear the relevant personal protective equipment (PPE). Refer to section 2.4
- Never work alone (to prevent the possibility of an accident)
- Read the plant requirements for handling hazardous materials

2.3 Trained and qualified personnel

Qualified personnel are people who have been authorized by those responsible for the safety of the plant to perform the necessary work, and who can recognize and avoid possible dangers. The following aspects determine the qualification of personnel:

- Appropriate training
- Relevant experience
- Knowledge of relevant standards and specifications
- Knowledge of accident prevention regulations
- Knowledge of plant regulations and operating conditions

2.4 Personal protective equipment (PPE)

The 682R Reservoir is often used for applications containing high-pressure, high-temperature and/or toxic chemicals. When performing operating or maintenance tasks, make sure you wear the appropriate PPE: protective clothing, gloves, safety glasses, etc.

Always follow local regulations regarding PPE.

2.5 Actions in extreme conditions

In the unlikely event of emergency operating conditions always follow emergency plant regulations. Immediate evacuation of service personnel shall follow plant regulations.

3 Environmental Considerations

⚠ CAUTION: *You are required by law to dispose waste products and end of life equipment, according to local regulations.*

3.1 Disposing of waste products

Make sure waste products are diverted to a safe and suitable location. Always follow local and plant regulations.

Any waste products resulting from the use or maintenance of the 682R Reservoir must be recycled or disposed of according to local environment laws and regulations.

3.2 End-of-life equipment

STOP **WARNING – HAZARDOUS CHEMICALS:** *Dangerous chemical might be released during removal of the 682R Reservoir. Wear Personal Protective Equipment (PPE). Follow all safety regulations and Plant regulations.*

STOP **WARNING – HIGH PRESSURE:** *Take caution when de-pressurizing the 682R Reservoir. The 682R Reservoir might have energy stored inside. Make sure that de-pressurizing happens slowly.*

STOP **WARNING – HOT SURFACES:** *The 682R Reservoir and surrounding surfaces might be hot. Take care when touching components. Wear the appropriate PPE, according to plant regulations.*

When the equipment reaches the end of life, the shutdown procedure (section 7.4) shall be followed. The equipment must then be deinstalled and transported to a safe location. Always pay extra attention to safety!

NOTE: End-of-life equipment must be disposed of according to local environment laws and regulations.

4 Description

4.1 Product purpose

The 682R reservoir is used with dual mechanical seal arrangements (Plan 52, 53A). The purpose of the Flowserve's 682R reservoir is to improve the reliability and extend the life of the dual mechanical seal by providing a source for clean and cool barrier/buffer fluid, remove heat and control emissions from the mechanical seal.

NOTE: The images of parts shown in these instructions may differ visually from the actual parts due to manufacturing processes that do not affect the part function or quality. Refer to specific product drawing for connection and dimensional details.

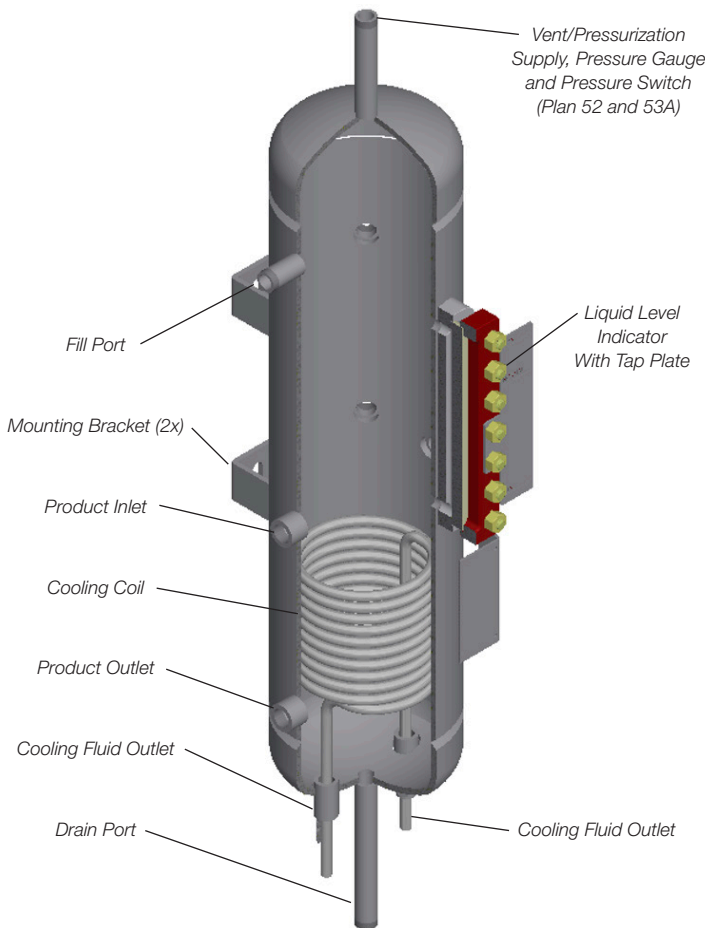

Figure 1: 682R51 Reservoir sectional view

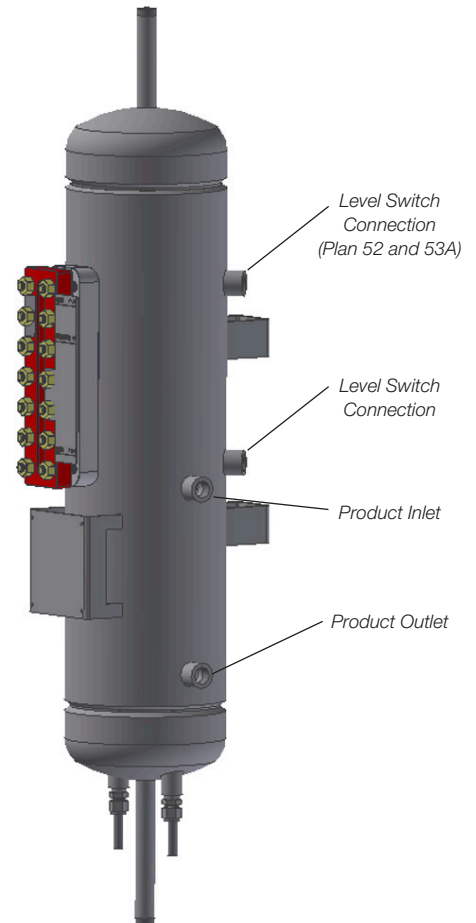

Figure 2: 682R51 external view

4.2 Mechanical seal arrangements

The mechanical seal arrangements used for the 682R reservoir are shown in the following figures with its corresponding P&ID.

- PG:** Pressure Gauge
- PS:** Pressure Switch
- LSH:** Level Switch High
- LSL:** Level Switch Low
- LG:** Level Gauge
- PIT:** Pressure Indicator Transmitter
- LT:** Level Transmitter

Per API 682 4th Edition, the reservoir is provided with transmitters as standard. Switches are available as an option when specified by the customer.

The P&ID's on Figures 3 and 4 show the bare reservoir and optional instrumentation. Refer to the 682R Smart Drawing for a full list of instrumentation available.

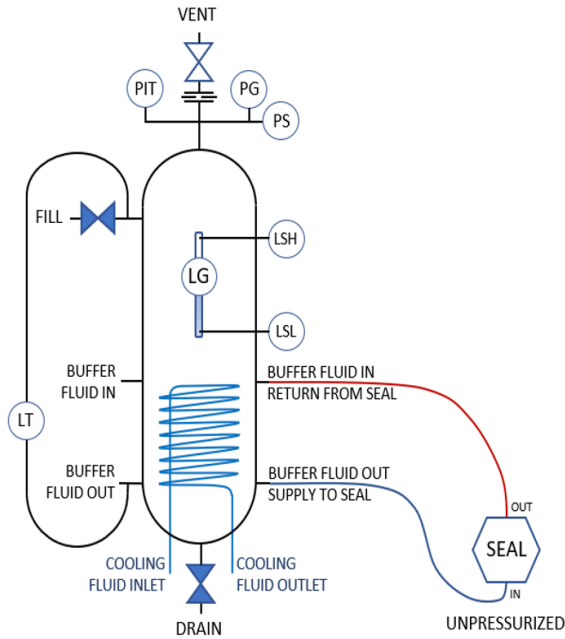

Figure 3: Recommended P&ID piping plan 52

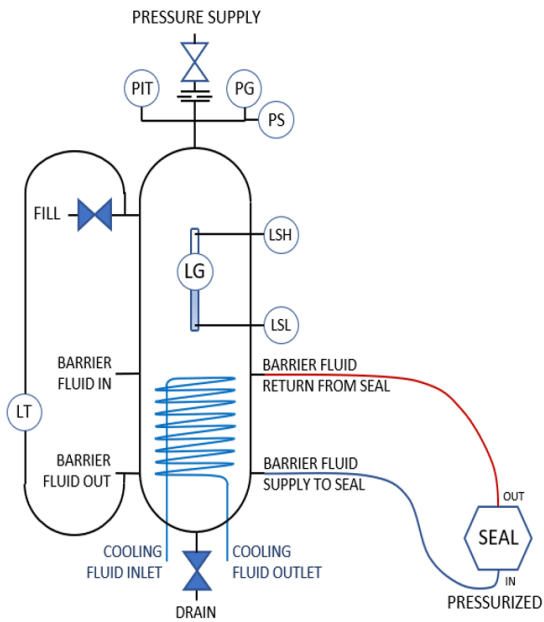

Figure 4: Recommended P&ID piping plan 53A

Piping Plan 52 is an unpressurized dual seal system which is used in services where no leakage to atmosphere is tolerated. The system consists of dual mechanical seals with a buffer fluid between the seals. The buffer fluid is contained in the seal pot which is vented to a flare, thus maintaining the buffer fluid pressure close to atmosphere. Primary (inboard) seal leakage will be product leakage into the buffer fluid. There will always be some leakage.

Plan 52 relies on fluid circulating from the reservoir to the mechanical seal. Circulation can come from a circulation feature in the mechanical seal and/or a thermosyphon effect with the buffer fluid. When a thermosyphon effect is used, the circulation of liquid occurs due to natural convection (as opposed to mechanical pumping). The temperature difference between seal and reservoir will cause different density across the loop; hence, thermal expansion.

Warmer liquid will float above the cooler, moving the buffer fluid upwards, from the seal towards the reservoir.

In a Piping Plan 52 there is an external reservoir providing buffer liquid for the outer seal of an arrangement 2 seal. The buffer liquid shall be maintained at a pressure less than seal chamber pressure and less than 0.28 MPag (2.8 barg, 40 psig).

Plan 52 works best with clean, non-polymerizing products which have a vapor pressure higher than the buffer fluid pressure.

These products will flash in the supply tank and the vapor can escape to the vent system. If the product has a vapor pressure lower than the buffer fluid or supply tank pressure, the leakage will remain a liquid and will cause the buffer fluid level to rise.

Should excessive primary (inboard) seal leakage not be detected early, the heavier process fluid will displace the buffer fluid and can result in increased seal wear. Used with dual unpressurized seals, high vapor pressure fluids, light hydrocarbons, hazardous or toxic fluids, and heat transfer fluids. Refer to Figure 5 in the following page.

Piping Plan 53A is a pressurized dual seal system which is used in services where no process leakage to atmosphere is tolerated. The system consists of dual mechanical seals with a barrier fluid between them. The barrier fluid in the supply tank is pressurized to a higher pressure than the seal chamber, normally 15 to 25 psig (1 to 1.7 barg). Primary (inboard) seal leakage will be barrier fluid into the product. A small amount of leakage is customary.

A Plan 53A is usually chosen over a Plan 52 for dirty, abrasive or polymerizing products which would either damage the seal faces or cause problems with the barrier fluid system if a Plan 52 is used. There are two disadvantages to a Plan 53A which must be considered. First, there will always be some leakage of barrier fluid into the product. Normally, this leakage will be minute, and the leakage rate can be monitored via the level gauges or other instrumentation; however, the product must be able to accommodate a small amount of contamination from the barrier fluid. Secondly, a Plan 53A system is dependent on having the supply tank pressure maintained at the proper level. If the supply tank pressure drops, seal leakage direction will be reversed (the seal system will begin to operate like a Piping Plan 52) and the barrier fluid will be contaminated with the process fluid.

Used with high vapor pressure fluids, light hydrocarbons, hazardous or toxic fluids, heat transfer fluids, dirty/abrasive or polymerizing fluids, and mixer or agitators and vacuum services, refer to Figure 6.

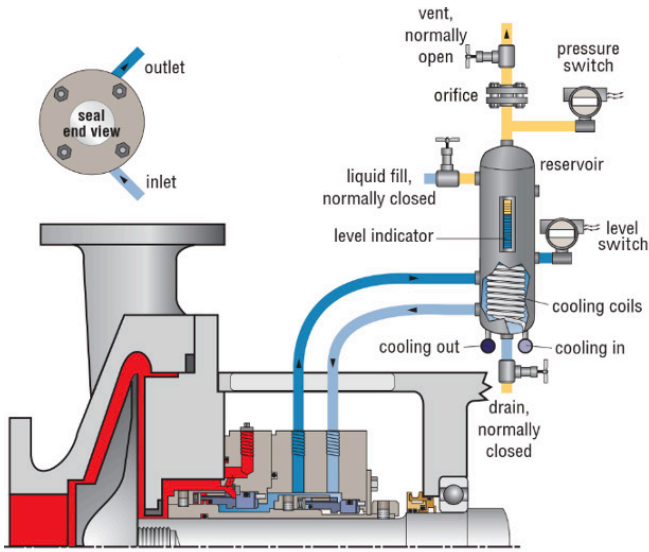

Figure 5: Piping Plan 52 configuration

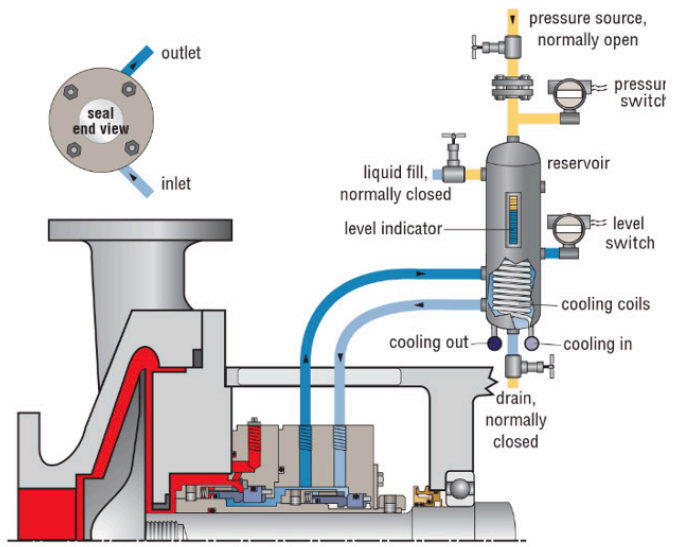

Figure 6: Piping Plan 53A configuration

4.3 Design features

		NPT	FLANGED CL 600
MAWP		75.5 bar @ 204°C (1,095 psi @ 400°F)	70.7 bar @ 204°C (1,025 psi @ 400°F)
MDMT		-45.5°C @ 75.5 bar (-50°F @ 1,095 psi)	-45.5°C @ 70.7 bar (-50°F @ 1,025 psi)
MIN OPERATING TEMP		-40°C (-40°F)	-40°C (-40°F)
HYDRO TEST		113.3 bar (1,643 psi)	106.1 bar (1,538 psi)
WEIGHT		160 kg (353 lb)	167 kg (368 lb)
VOLUME	RESERVOIR (SHELL)	27 liters (7 gallons)	30 liters (8 gallons)
	RESERVOIR N.L.L.	19 liters (5 gallons)	19 liters (5 gallons)
	COIL TUBE	0.5 liters (0.13 gallons)	0.5 liters (0.13 gallons)

5 Preservation, Packing, Transport and Storage Requirements

5.1 Mechanical preservation instructions

5.1.1 Preservation

Equipment should not be sealed in a way that it will obstruct inspection. Access for normal inspection and preservation maintenance shall be provided. Internal surfaces of pressure vessels, piping systems and similar equipment shall be dried and cleaned of surface corrosion and foreign material.

The 682R Reservoir shall be thoroughly cleaned and dried after manufacturing and testing, prior to application of preservatives.

For equipment where water is used for cleaning or pressure testing, the water shall have antifreeze medium added unless the water is completely drained off. This also applies if the ambient temperature is below 4°C during any of these operations.

Internal surfaces wholly consisting of corrosion resistant materials shall not be preserved unless stated otherwise.

5.1.2 De-preservation

For de-preservation the applicable dust caps/plugs need to be removed prior to commissioning. During hook up it is mandatory to keep these caps/plugs in place for as long as possible to prevent contamination.

5.2 Packing

 **WARNING – CRUSH HAZARD: Possible injury and/or trapped limbs. Take care to avoid being trapped or crushed between heavy, moving objects when (un)boxing the cooler.**

The 682R Reservoir shall be lifted carefully with proper equipment.

Always make sure that proper lifting devices are used.

To prevent damage during transport all equipment needs to be properly secured inside their package with suitable bolting, straps or wooden supports.

For unboxing, the equipment must be lifted carefully out of its shipping box.

5.3 Transportation and storage requirements

NOTE: The following requirements apply to the 682R Reservoir and all related equipment:

Table 2 - Transport and Storage Criteria

Transport and storage criteria	Requirements
Transportation	The system must be transported and stored in the unopened, original shipping box.
Suspect damaged during transportation	Carefully inspect equipment that has been dropped or has been subjected to impacts during transport to confirm that they are operational before installation.
Warehouse requirements	The warehouse must be dry and dust free.
Long-term storage	After a storage period of 2 years, inspect the 682R Reservoir before installation.
Preserving installed 682R Reservoir Series	The preserving medium prevents damage to the installed system or mechanical seal (i.e. preventing fouling or chemical attack). Contact Flowserve if you are unsure which preserving medium to use.

6 Installation

6.1 Introduction

STOP **WARNING – CRUSH HAZARD: Possible injury and/or trapped limbs. Take care to avoid being trapped or crushed between heavy, moving objects when installing the coolers.**

Before installing the 682R Reservoir, make sure you have read and understood the installation requirements in this section. If you have any questions regarding the installation of the 682R Reservoir, contact your local Flowserve representative.

6.2 Safety considerations

STOP **WARNING – CHECK BEFORE DISASSEMBLING: Under no circumstances should the 682R Reservoir be disassembled while it still contains any hazardous materials or when it is pressurized.**

X **DANGER – SUFFOCATION HAZARD: Breathing hazardous chemicals in a confined space can result in sudden unconsciousness or death. Take extra care when working in confined areas.**

Position the 682R Reservoir as close to your main equipment as possible. Make sure there is sufficient room for:

- Evacuation of the plant in case of an emergency (do not block walkways and emergency exits)
- Safe operation and maintenance of the system

6.3 Installation requirements

Before installation the following shall be checked:

- Any possible damage due to transport or storage
- Cleanliness, required before operation
- Existence of the nameplate with correct inspection markings and design/test conditions

6.4 Product set-up

6.4.1 Mounting

- The optimum mounting height is defined by the viscosity of the fluid, the hydraulic resistance and the pressure head required for proper flow supply. Consider the source of the pressure: A pump ring provides a lower pressure head vs. a recirculation pump.
- Generally, the reservoir shall be mounted such that the normal liquid level (NLL) is a minimum of 0.9 m (3 ft) above the seal centerline, and the reservoir centerline is a maximum of 1.2 m (4 ft) horizontally from the pump centerline as shown in Figure 7.

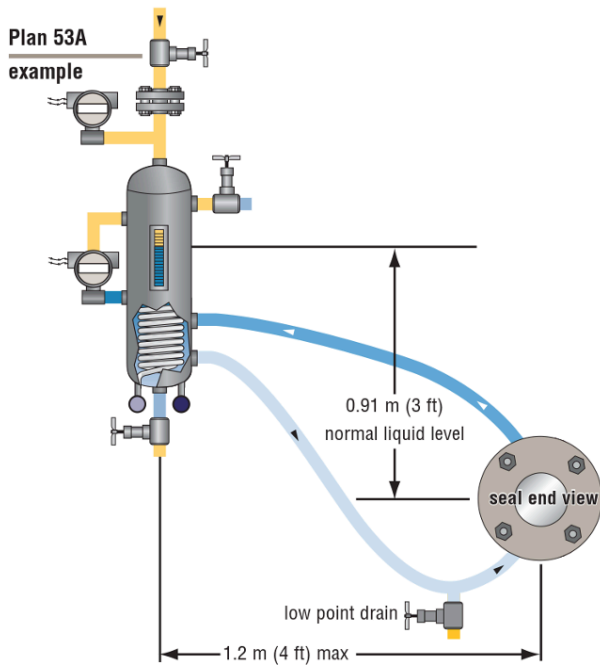

Figure 7: Piping Plan 53A mounting dimensions example

- It is highly recommended that the reservoir be flushed with clean fluid prior to equipment start-up to remove any foreign matter from the system.
 - Connect the supply connection (lower seal connection on the reservoir) to the bottom (inlet) gland connection (BI - inlet).
 - Connect the return connection (upper seal connection on the reservoir) to the upper (outlet) gland connection (BO - outlet).
 - If the reservoir is equipped with cooling coils, connect water lines to the coil connections on the bottom of the reservoir.
 - Connect wiring to any instruments included with the system such as a pressure switch/transmitter or level switch/transmitter.
 - For the liquid level indicator, the bolts on the cover should be retorqued to 20 ft/lbs. (Tighten in 5 ft/lb. increments starting with the center bolts and working out).
- In case that a different torque is specified in the liquid level indicator, it should be followed.
- Connect vent connection to flare or vapor recovery system (Plan 52).
- Do not open vent valve until reservoir has been filled with buffer fluid.
- If using oil as a barrier fluid (Plan 53A), fill reservoir up to the middle of the liquid level indicator. Then connect the external pressurization (gas line).
 - If using water as a barrier fluid (Plan 53A WM), connect external pressurization (water supply) to reservoir.
 - Maintain a constant pressure on the system. The pressure should be less than 2.8 bar (40 psi) for a Plan 52 and seal chamber plus 1.4 bar (20 psi) for a plan 53A.

6.4.2 Connections

6.4.2.1.682R Reservoir in a buffer/barrier plan

When the 682R Reservoir is used in a buffer/barrier plan (plan 52, 53), the top connection shall be connected to the buffer/barrier outlet connection of the mechanical seal, while the bottom flange shall be connected to the buffer/barrier inlet connection of the mechanical seal.

6.4.3 Interconnecting piping

The flow of fluid through the 682R Reservoir is either generated by:

- A pumping device, included in the seal design
- A circulation pump
- Thermosyphoning by natural convection

The interconnecting piping between the 682R Reservoir and the main equipment must be correctly fitted; otherwise the flow of the fluid through the 682R Reservoir will be restricted and have a negative impact on the performance.

Pay attention to the following points:

- Minimize the number of restrictions (for example, limit the number of elbow/tee fittings).
- Unless otherwise specified, the pipe size should be 0.75 in. and schedule shall be the same as the system piping.
- The pipes must be clean and free of burrs.
- The total pipe length and number of bends shall be kept to a minimum.
- Use smooth, large radius bends; do not use elbows, tees, etc.
- Pipe runs should be sloped continuously up or down to allow for adequate circulation, proper venting and draining.
- Make sure that the loop, including seal flange, does not include vapor traps. When vapor traps cannot be avoided, a proper venting solution shall be added.
- For threaded connections, do not use Teflon tape but an anaerobic thread sealant.
- Leak testing is recommended after assembly. Refer to end user specifications or procedures.

6.5 Installation procedure

Use this procedure to install or reinstall the system.

Procedure

1. Before installing the 682R Reservoir, inspect all components for damage. If any of the components are damaged, you should report this to your local Flowserve representative. Refer to section 6.3.
2. Determine the installed position of the system. Refer to the mounting requirements, section 6.4.1.
3. The 682R Reservoir shall not be moved by hand. It is equipped with a lifting lug. Use an appropriate lifting device to position the 682R Reservoir as close as possible to the main equipment. Make sure you leave sufficient room for operation and maintenance purposes.

 **WARNING – CRUSH HAZARD: Possible injury and/or trapped limbs. Take care to avoid being trapped or crushed between heavy, moving objects when installing the cooler**

4. Make sure that the 682R Reservoir is installed in a rigid support to counteract any vibrations and instability.

 **WARNING – HIGH PRESSURE: Take caution when de-pressurizing the 682R Reservoir. The 682R Reservoir might have energy stored inside. Make sure that de-pressurizing happens slowly.**

5. Connect the 682R Reservoir connections. Refer to section 6.4.2.
6. Manufacture the interconnecting piping according to the Installation requirement. Refer to section 6.4.3.
7. Make sure the installation is correctly earthed to prevent the potential risk of explosion caused by static electricity.

NOTE: Leak testing is recommended after assembly. Refer to end user specifications or procedures.

6.6. Transmitter and switch alarm set points

- The instrument alarm setting depends on the purpose of the specific instrument (high alarm for Plan 52 and low alarm for Plan 53A). A high level switch shall be set to normally open (not detecting liquid), while a low level switch shall be set to normally closed (detecting liquid).
- For the Plan 52 the pressure transmitter or pressure switch shall provide a high-pressure alarm between 0.3 to 2.1 bar (5 to 30 psi). The alarm set point should be below seal chamber pressure, typically less than 2.1 bar (30 psi).
- For the Plan 53A the pressure transmitter or pressure switch shall provide a low-pressure alarm between 1.6 to 10.3 bar (24 to 150 psi). The alarm set point should ensure the reservoir pressure is at least 1.4 bar (20 psi) higher than seal chamber.
- For additional information on how to install or set alarm points on the instrumentation, refer to the IOM specific to the instrument.

7 Operation

7.1 Start-up

1. Make sure the 682R Reservoir is installed correctly, refer to chapter 6.5.
2. Open the interconnecting valving for the system.
3. Make sure commissioning of the system has been performed properly. Ensure that all the trapped gas/air is vented from the system and interconnecting piping and that the system can be completely drained.
4. Start up the pump according end user/plant procedures.

7.2 Product monitoring

 **WARNING – HIGH PRESSURE:** Take caution when de-pressurizing the 682R Reservoir. The 682R Reservoir might have energy stored inside. Make sure that de-pressurizing happens slowly.

 **WARNING – HOT SURFACES:** The 682R Reservoir and surrounding surfaces might be hot. Take care when touching components. Wear the appropriate PPE, according to plant regulations.

 **WARNING – HAZARDOUS CHEMICALS:** Hazardous chemicals might be released during removal of the 682R Reservoir. Wear PPE. Follow all safety regulations and plant regulations.

1. Monitor the 682R Reservoir for correct operation. Also refer to the Periodic maintenance tables in section 8.2.
2. Make sure:
 - There are no leaks
 - There is no cavitation in the system
 - There is no heavy vibration in the system
3. If you notice any problems with the 682R Reservoir, follow plant regulation for reporting and correcting faulty equipment.

682R Reservoir performance should be monitored periodically. Baseline temperatures should be collected soon after equipment commissioning.

Periodically the 682R Reservoir temperature, pressure and flow should be monitored to prevent damage or failure to the equipment.

7.3 Shut down product

STOP **WARNING – HIGH PRESSURE:** *Take caution when de-pressurizing the 682R Reservoir. The 682R Reservoir might have energy stored inside. Make sure that de-pressurizing happens slowly.*

STOP **WARNING – HOT SURFACES:** *The 682R Reservoir and surrounding surfaces might be hot. Take care when touching components. Wear the appropriate PPE, according to plant regulations.*

STOP **WARNING – HAZARDOUS CHEMICALS:** *Hazardous chemicals might be released during removal of the 682R Reservoir. Wear PPE. Follow all safety regulations and Plant regulations.*

The 682R Reservoir may be disconnected only by qualified personnel, in accordance with national, facility and end-user safety regulations and Chapter 2 in this manual.

Check if the 682R Reservoir can be shut down. Check if the 682R Reservoir can be de-pressurized without negatively affecting the mechanical seal installed in main equipment. System cannot be shut down if any of the following main equipment conditions occur:

- Main equipment/pump is on hot stand-by
- Main equipment/pump is pressurized
- Main equipment/pump is in operation

NOTE: Always shut down the system according to plant regulations/end user safety procedures.

- Make sure the pump is shut down according to end-user and facility regulations.
- Isolate the system.
- De-pressurize and drain the 682R Reservoir.

8 Maintenance

8.1 General guidelines

Periodic maintenance must be done at regular intervals (weekly, monthly, yearly). Refer to the following tables.

All liabilities and warranties to Flowserve for damage incurred using non-original replacement parts and accessories will be rendered null and void.

8.2 Periodic maintenance tables

Use the following tables to plan the periodic maintenance for your system (refer to the table of contents and the Appendix for the relevant information)

Table 3 - Periodic Maintenance Tables

Weekly maintenance
Check the seal, 682R Reservoir, and interconnecting pipe work for leaks. Rectify if necessary.
Check if the 682R Reservoir is not vibrating.
Check the fluid pressure, flow and temperature.

Monthly maintenance
Confirm Reservoir installation.
Check the fluid for impurities.
Vent the 682R Reservoir interconnecting pipelines as needed.

8.3 Inspection procedure

STOP **WARNING – HIGH PRESSURE:** Take caution when de-pressurizing the 682R Reservoir. The 682R Reservoir might have energy stored inside. Make sure that de-pressurizing happens slowly.

STOP **WARNING – HOT SURFACES:** The 682R Reservoir and surrounding surfaces might be hot. Take care when touching components. Wear the appropriate PPE, according to plant regulations.

STOP **WARNING – HAZARDOUS CHEMICALS:** Hazardous chemicals might be released during removal of the 682R Reservoir. Wear PPE. Follow all safety regulations and plant regulations.

The product maintenance procedure is as follows:

- Remove the 682R Reservoir from service. Refer to section 7.3, Shut down product.
- Clean the 682R Reservoir internally and externally. Follow the assembly drawing. If in doubt, ask a Flowserve representative for clarification.
- Inspect all components for damage or corrosion and replace as needed.
- Re-install the 682R Reservoir. Refer to section 6.5, Installation procedure.

9 Troubleshooting

Use the following table to troubleshoot the system. Once you have identified the problem, use the procedures in this manual to maintain the Reservoir. If you are not sure how to troubleshoot or maintain your 682R Reservoir, please contact your local Flowserve representative.

NOTE: the recommended response actions always include notify the supervisory authority and respond according to plant regulation.

Table 4 - Localization and Elimination of Vaults, Damages and their Consequences

Parameter	Indication	Possible cause	Solution
Pressure	Low	<ul style="list-style-type: none"> Leakage in connections, gaskets, piping Mechanical seal failure Flush/Barrier source supply pressure fails. 	<ul style="list-style-type: none"> Check connections for leakage Check gaskets for leakage Check piping for leakage Check mechanical seal
Pressure	High	<ul style="list-style-type: none"> Inner mechanical seal failure Process discharge closed 	<ul style="list-style-type: none"> Repair mechanical seal Open discharge line
Flow	Low	<ul style="list-style-type: none"> Closed seal supply or seal return isolation valve Clogged interconnecting piping Flush/Barrier source supply pressure fails 	<ul style="list-style-type: none"> Check for blockages, open valves as necessary Localize blockage and resolve Review supply source
Temperature	High	<ul style="list-style-type: none"> Insufficient cooling fluid supply Insufficient cooling fluid temperature Cooling coil is clogged 	<ul style="list-style-type: none"> Check the temperature and flow rate of the cooling fluid Check cleanliness of the cooling coil, remove contaminants as required

ANNEX I

System logbook

Copy and use this logbook to record periodic or corrective maintenance done on your system. Use the following codes and enter remarks, the date, and your name:

Weekly maint.= W	Monthly maint. = M	Yearly maint.= Y	Adjust = A	Replace = R
------------------	--------------------	------------------	------------	-------------

Code	Remarks	Date	Name

ANNEX II

Page is left blank intentionally

**Flowserve Corporation**

No. 35, Baiyu Road
Suzhou Industrial Park
Suzhou 215021, Jiangsu Province, PRC
Phone: +86-512-6288-1688
Fax: +86-512-6288-8737

Flowserve Pte Ltd.

No. 12 Tuas Avenue 20
Singapore 638824
Phone: +65 6879 8900
Fax: +65 6862 4940

Flowserve Corporation

Flow Control Division
1978 Foreman Drive
Cookeville, Tennessee 38501 USA
Phone: +1-931-432-4021
Fax: +1-931-432-5518

Flowserve Corporation

Flow Control Division
1350 North Mountain Springs Parkway
Springville, Utah 84663-0913 USA
Phone: +1-801-373-3028
Fax: +1-801-489-2228

Flowserve Flow Control (UK) Ltd.

Burrell Road
Haywards Heath
West Sussex United Kingdom
RH16 1TL
Phone: +44-1444-314400
Fax: +44-1444-314401

Flowserve Ahaus GmbH

von-Braun-Str. 19a
48683 Ahaus
Phone: +49-2561-686-119
Fax: +49-2561-686-109

Flowserve Flow Control GmbH

Actuators and Automation Center
Germany
Rudolf Plank Str. 2
D-76275 Ettlingen
Germany
Phone +49 (0)7243-103-0
Fax +49 (0)7243-103-222

Flowserve Flow Control Benelux BV

Rechtzaad 17
4703 RC Roosendaal NB Netherlands
Phone: +31-165-598-800
Fax: +31-165-555-670

Flowserve India Controls Pvt Ltd.

Plot No. 4, 1A, E.P.I.P, Road No. 8
Whitefield, Bengaluru
Karnataka 560066, India

Flow Control Division Brazil

Rua Tocantins, 128
09580-130 - São Caetano do Sul - SP
Brazil

Headquarters

Flowserve Corporation
5215 North O'Connor Blvd.
Suite 700
Irving, Texas 75039-5421 USA
Telephone: +1-937-890-5839

Flowserve Corporation has established industry leadership in the design and manufacture of its products. When properly selected, this Flowserve product is designed to perform its intended function safely during its useful life. However, the purchaser or user of Flowserve products should be aware that Flowserve products might be used in numerous applications under a wide variety of industrial service conditions. Although Flowserve can provide general guidelines, it cannot provide specific data and warnings for all possible applications. The purchaser/user must therefore assume the ultimate responsibility for the proper sizing and selection, installation, operation, and maintenance of Flowserve products. The purchaser/user should read and understand the Installation Instructions included with the product, and train its employees and contractors in the safe use of Flowserve products in connection with the specific application.

While the information and specifications contained in this literature are believed to be accurate, they are supplied for informative purposes only and should not be considered certified or as a guarantee of satisfactory results by reliance thereon. Nothing contained herein is to be construed as a warranty or guarantee, express or implied, regarding any matter with respect to this product. Because Flowserve is continually improving and upgrading its product design, the specifications, dimensions and information contained herein are subject to change without notice. Should any question arise concerning these provisions, the purchaser/user should contact Flowserve Corporation at any one of its worldwide operations or offices.

©2022 Flowserve Corporation. All rights reserved. This document contains registered and unregistered trademarks of Flowserve Corporation. Other company, product, or service names may be trademarks or service marks of their respective companies.

SSIOM000743-00 (EN/A4) November 2022