

Worcester[®] 51/52 Series Reduced Port Flanged Ball Valve

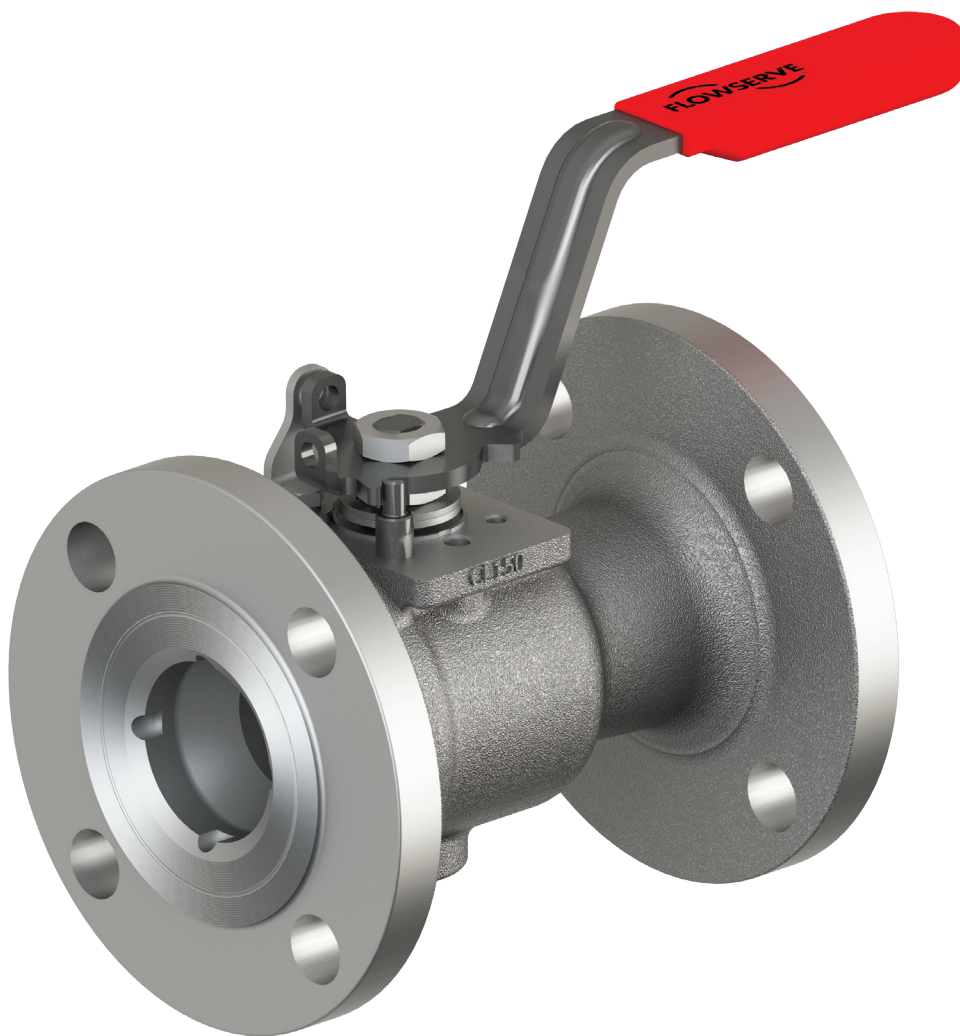

Designed for global availability and lower total costs

The proven Worcester 51/52 series flanged ball valve from Flowserve has been engineered for worldwide availability and shorter lead times by standardizing its design, materials and construction.

As a result, the 51/52 series valve minimizes fugitive emissions, enhances safety, and ensures regulatory and standards compliance to help companies achieve decarbonization and sustainability objectives. The globalized design meets critical certifications and standards in all jurisdictions.

Specifying the 51/52 series valve also enables companies to lower the total cost of ownership owing to the standardization and interchangeability of parts, which are available in all regions.

In addition, Flowserve provides superior technical support and service available from a global network of Quick Response Centers (QRCs).

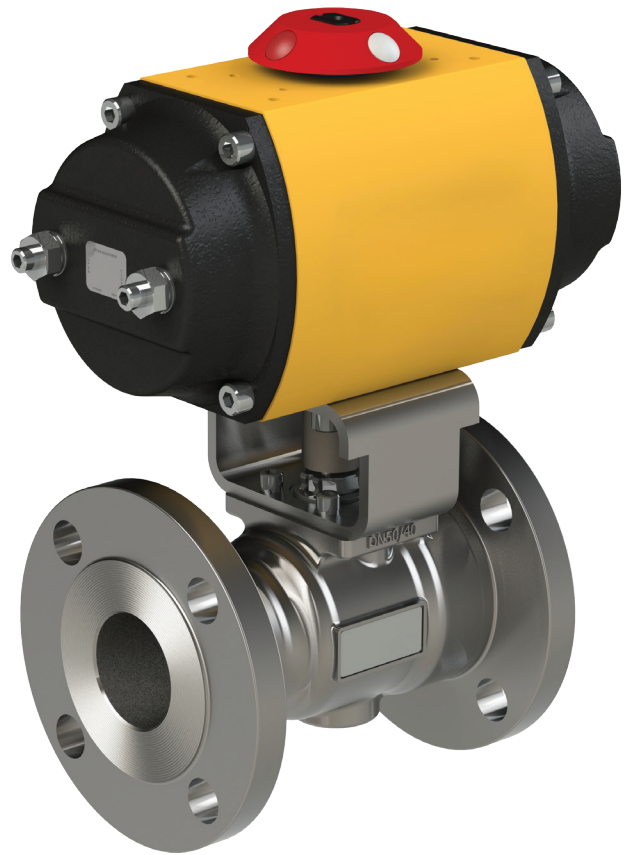

Standardized for reliability, compliance and safety

To avoid regulatory and financial risks that can occur because of fugitive emissions, Flowserve designed the Worcester 51/52 series valve to provide superior leakage resistance with a bubble-tight shutoff and a more robust, live-loaded packing design. Safety has been enhanced for end users as a result of the threaded end plug design, which ensures positive retention and eliminates any blowout risk.

Industries and applications

Chemical processing	Petrochemicals	Energy	Other industries
<ul style="list-style-type: none"> • Thermal fluids • Oxygen services • Ammonia • Chlorine • Hydrogen peroxide • Phosgene 	<ul style="list-style-type: none"> • BTX • Ethylene • Polyolefins/aromatics 	<ul style="list-style-type: none"> • Gasification • Hydrogen • Liquefied natural gas (LNG) • Steam 	<ul style="list-style-type: none"> • Defense • Food and beverage • Industrial gases • Pharmaceuticals • Water

Features and benefits

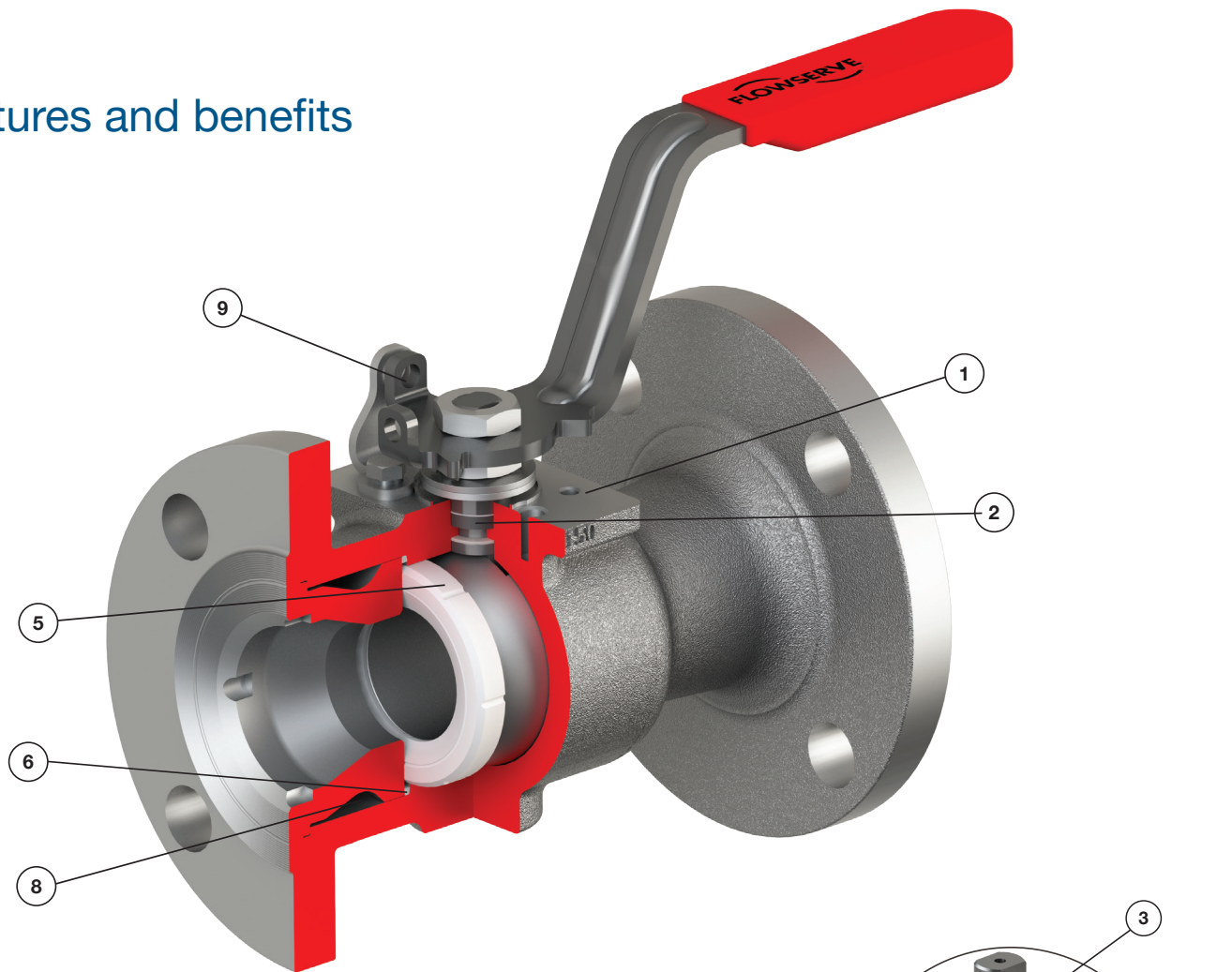

1 Actuator mounting conforms to ISO 5211 and Shell MESC SPE 77/300 for ease of actuation.

2 Standard anti-blowout, duplex stainless steel stem provides greater safety, increased maximum allowable stem torque (MAST) and excellent durability.

3 Locking clip (see inset) maintains position of the gland nut during actuation for long, leak-free performance; the **gland nut** does not need to be removed for actuator mounting, thereby maintaining valve integrity.

4 Live-loaded packing (see inset) for enhanced reliability; conforms to API 641 and ISO 15848 fugitive emissions certification standards.

5 Seat design is available in a wide range of materials to meet specific application requirements; the cavity pressure-relieving (CPR) design ensures that pressure generated through media expansion when the valve is closed is safely relieved upstream.

6 Body seals are PTFE as standard with fire-safe integrity maintained with metal-to-metal secondary sealing; compliant with API 607, API 608, API 641, ISO 17292 and ISO 15848.

7 Anti-static design is standard.

8 Threaded insert provides leak-tight positive retention and improved customer safety.

9 Locking wrench is standard on sizes through NPS 4 (DN100).

Optional O-ring stem seal is available for improved stem sealing performance, particularly in vacuum applications.

Parts and materials lists

Sizes DN15 to DN50 (NPS ½ to 2)

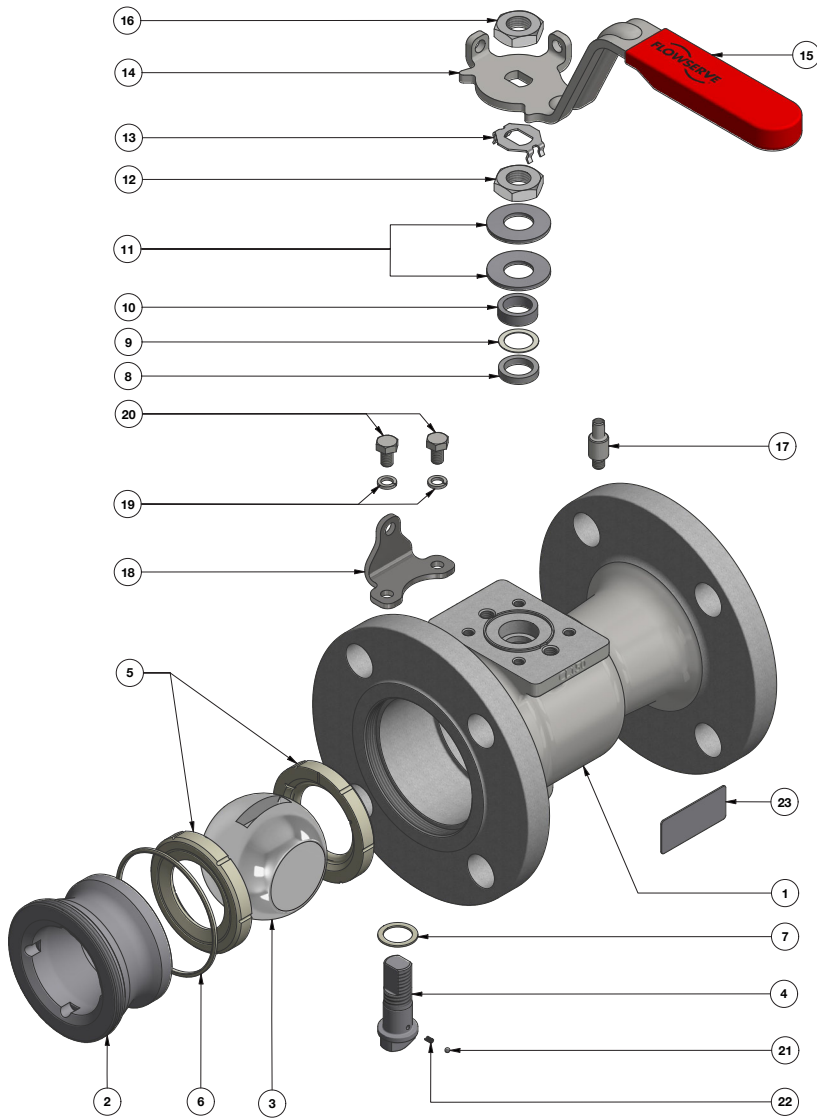

Item	Description	Material
1	Body*	ASTM A351 CF8M Stainless Steel
2	Insert*	ASTM A351 CF8M Stainless Steel
3	Ball	ASTM A479 316 or A351 CF8M Stainless Steel
4	Stem	ASTM A479 S31803 Duplex Stainless Steel
5	Seat	Virgin PTFE
6	Body Seal	Virgin PTFE
7	Stem Thrust Seal	25% Glass-Filled PTFE
8	Gland Packing	Flexible Graphite
9	Bearing Washer	25% Glass-Filled PTFE
10	Gland	AISI 316 Stainless Steel
11	Belleville Washer	Stainless Steel
12	Gland Nut	Stainless Steel
13	Gland Nut Locking Clip	Stainless Steel
14	Locking Wrench	Stainless Steel
15	Wrench Sleeve	Vinyl Plastisol
16	Wrench Nut	Stainless Steel
17	Stop Pin	Stainless Steel
18	Locking Plate	Stainless Steel
19	Washers	Stainless Steel
20	Hex Head Screws	Stainless Steel
21	Anti-static Ball	Stainless Steel
22	Anti-static Spring	Stainless Steel
23	Identification Plate	Stainless Steel

*Body and insert available in LCB and other alloys

Worcester® 51/52 Series Reduced Port Flanged Ball Valve

Sizes DN80 to DN200 (NPS 3 to 8)

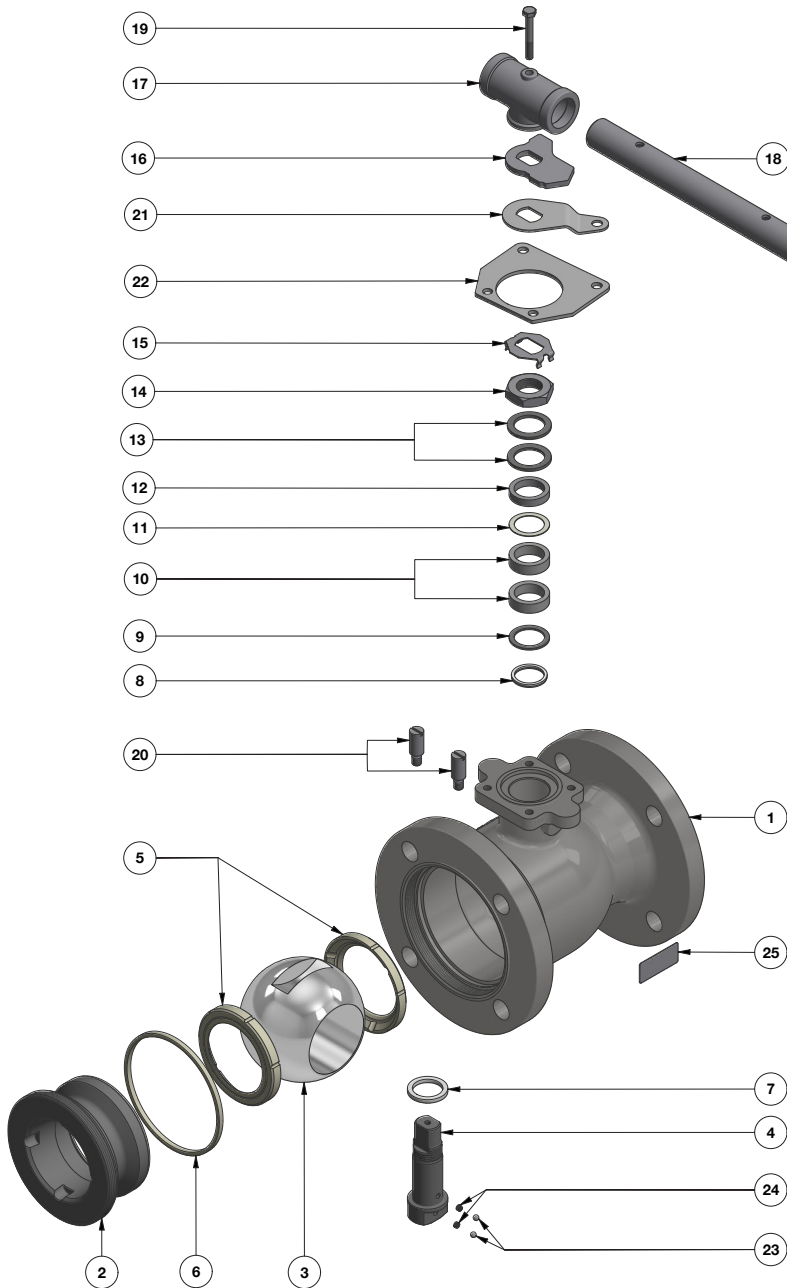

Item	Description	Material
1	Body	ASTM A351 CF8M Stainless Steel
2	Insert	ASTM A351 CF8M Stainless Steel
3	Ball	ASTM A351 CF8M Stainless Steel
4	Stem	ASTM A479 S31803 Duplex Stainless Steel
5	Seat	Virgin PTFE
6	Body Seal	Virgin PTFE
7	Stem Thrust Seal	25% Glass-Filled PTFE
8	Secondary Stem Seal	Virgin PTFE
9	Stem Location Ring	Stainless Steel
10	Gland Packing	Flexible Graphite
11	Bearing Washer	25% Glass-Filled PTFE
12	Gland	AISI 316 Stainless Steel
13	Belleville Washer	Stainless Steel
14	Gland Nut	Stainless Steel
15	Gland Nut Locking Clip	Stainless Steel
16	Stop Plate	AISI 316 Stainless Steel
17	Wrench Head	Stainless Steel
18	Wrench Handle	Stainless Steel
19	Hexagon Headed Bolt	Stainless Steel
20	Stop Pin	Stainless Steel
21	Moving Plate	Stainless Steel
22	Fixed Plate	Stainless Steel
23	Anti-static Ball	Stainless Steel
24	Anti-static Spring	Stainless Steel
25	Identification Plate	Stainless Steel

Body and insert available in LCB and other alloys

Pressure/temperature ratings

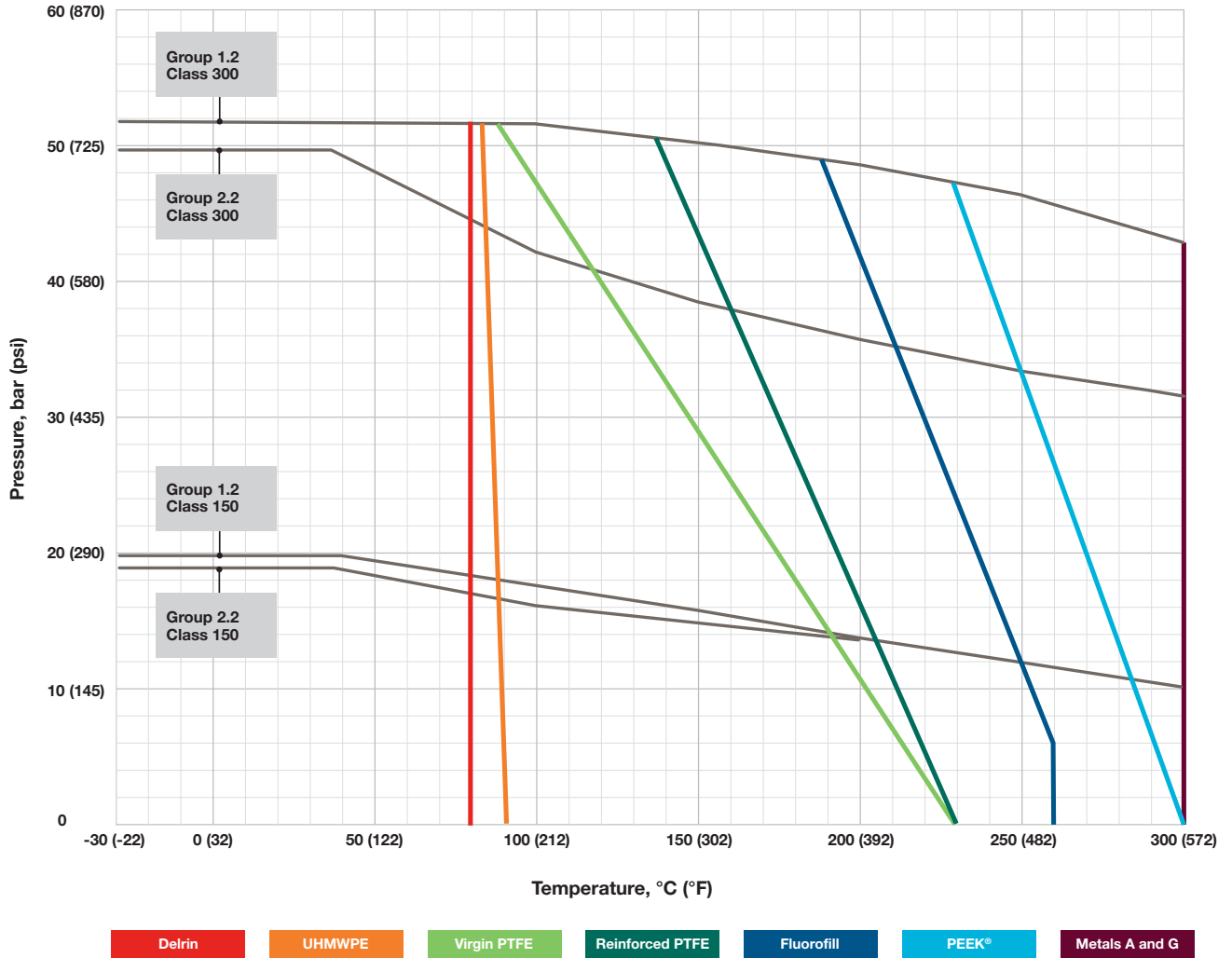

Material group pressure-temperature ratings are taken from ASME B16.34.

- Group 1.2 represents our dual-certified LCB/LCC and WCB/WCC materials.
- Group 2.2 represents our CF8M material.
- See page 7 for maximum seat temperature limits.

© PEEK is a registered trademark of Victrex plc Corp.

Seat materials

Refer to page 6 to see pressure/temperature curves for each seat material.

Delrin (D)

Delrin, also known as POM or acetal homopolymer, is a durable and tough low-friction material. Its superior creep resistance means it performs excellently in high-pressure applications.

Maximum temperature rating of 80°C (180°F)

UHMWPE (U)

Ultra-high molecular weight polyethylene (UHMWPE) offers good performance characteristics in applications where PTFE is not suitable, e.g., tobacco duty. It also has good abrasion resistance.

Maximum temperature rating of 90°C (200°F)

Virgin PTFE (T)

Virgin PTFE, the most common sealing material, is suitable for almost all media since it has excellent chemical resistance. It also has an exceptionally low coefficient of friction, allowing for low valve operating torque.

Maximum temperature rating of 230°C (450°F)

Reinforced PTFE (R)

Seats made from PTFE reinforced with glass are stronger and more wear-resistant than virgin PTFE seats, making them more suitable for applications involving higher pressure/temperature ratings or high cycling.

Maximum temperature rating of 230°C (450°F)

Fluorofill/Polyfill (P)

Seats made from PTFE reinforced with carbon, glass and graphite have outstanding dimensional stability across a broad temperature range. This material is well-suited for a variety of thermal services, including steam and cryogenic applications. Due to its high cycling capabilities, Fluorofill seats are recommended for modulating control applications.

Maximum temperature rating of 260°C (500°F)

PEEK (X)

Polyether ether ketone (PEEK) demonstrates outstanding pressure capabilities at elevated temperatures, and that is why it has the highest P/T rating of our non-metallic seat materials. It also has very good chemical and abrasion resistance.

Maximum temperature rating of 300°C (600°F)

Metal (A or G)

Seats made from 316L sintered metal impregnated with PTFE (A) or graphite (G) help to reduce torque and improve operability. The strength of the metal creates seats which offer excellent abrasion resistance and pressure-handling capabilities at elevated temperatures.

Maximum temperature rating of 300°C (600°F)

Dimensions

Sizes DN15 to DN50 (NPS ½ to 2)

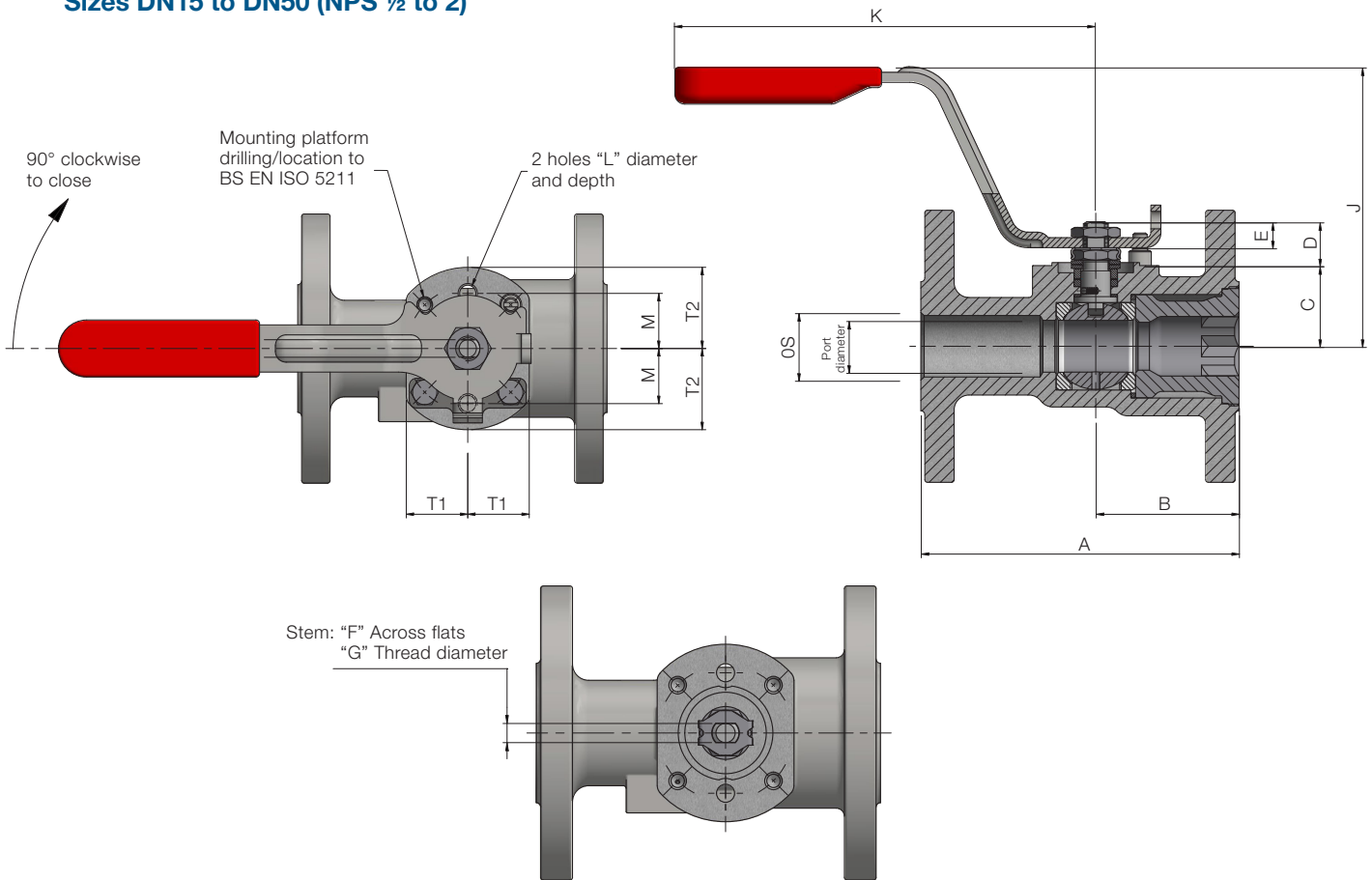

Dimensions indicated in mm (in.)

Valve Size DN	NPS	Valve Series	Min. Port Ø	A	B	C ⁽¹⁾	D ⁽¹⁾	E Min.	Stem		J	K	L Thread and Depth	M	S Ø	T1	T2	ISO Size ⁽²⁾	Approx. Weight kg (lb)
									F ⁽¹⁾	G Thread									
15	½	F51	11.1 (0.437)	108.0 (4.252)	52.5 (2.067)	22.96 (0.904) 22.70 (0.894)	18.0 (0.709) 17.0 (0.669)	8.1 (0.319)	7.00 (0.276) 6.96 (0.274)	M10 x 1.25p	102.6 (4.039)	155 (6.102)	M6 x 1.0p x 9.2 (0.362) Min.	16.9 (0.665)	15 (0.591)	19.2 (0.756)	23.25 (0.915)	F03	1.8 (4.0)
		F52	11.1 (0.437)	140.0 (5.512)	52.5 (2.067)	22.96 (0.904) 22.70 (0.894)	18.0 (0.709) 17.0 (0.669)	8.1 (0.319)	7.00 (0.276) 6.96 (0.274)	M10 x 1.25p	102.6 (4.039)	155 (6.102)	M6 x 1.0p x 9.2 (0.362) Min.	16.9 (0.665)	15 (0.591)	19.2 (0.756)	23.25 (0.915)	F03	2.4 (5.3)
20	¾	F51	14.4 (0.567)	117.0 (4.606)	54.6 (2.15)	22.96 (0.904) 22.70 (0.894)	18.0 (0.709) 17.0 (0.669)	8.1 (0.319)	7.00 (0.276) 6.96 (0.274)	M10 x 1.25p	102.6 (4.039)	155 (6.102)	M6 x 1.0p x 9.2 (0.362) Min.	16.9 (0.665)	20 (0.787)	19.2 (0.756)	23.25 (0.915)	F03	2.2 (4.9)
		F52	14.4 (0.567)	152.0 (5.984)	54.6 (2.15)	22.96 (0.904) 22.70 (0.894)	18.0 (0.709) 17.0 (0.669)	8.1 (0.319)	7.00 (0.276) 6.96 (0.274)	M10 x 1.25p	102.6 (4.039)	155 (6.102)	M6 x 1.0p x 9.2 (0.362) Min.	16.9 (0.665)	20 (0.787)	19.2 (0.756)	23.25 (0.915)	F03	3.6 (7.9)
25	1	F51	20.7 (0.815)	127.0 (5.000)	57.2 (2.252)	32.34 (1.273) 32.08 (1.263)	18.0 (0.709) 17.0 (0.669)	10.4 (0.409)	7.00 (0.276) 6.96 (0.274)	M10 x 1.25p	111.6 (4.394)	168 (6.614)	M8 x 1.25p x 9.7 (0.382) Min.	22.25 (0.876)	27 (1.063)	25.25 (0.994)	32.8 (1.291)	F05	3.1 (6.8)
		F52	20.7 (0.815)	165.0 (6.496)	57.2 (2.252)	32.34 (1.273) 32.08 (1.263)	18.0 (0.709) 17.0 (0.669)	10.4 (0.409)	7.00 (0.276) 6.96 (0.274)	M10 x 1.25p	111.6 (4.394)	168 (6.614)	M8 x 1.25p x 9.7 (0.382) Min.	22.25 (0.876)	27 (1.063)	25.25 (0.994)	32.8 (1.291)	F05	4.8 (10.6)
40	1½	F51	31.8 (1.252)	165.0 (6.496)	66.6 (2.622)	42.33 (1.667) 42.07 (1.656)	27.0 (1.063) 26.0 (1.024)	11.8 (0.465)	9.50 (0.374) 9.46 (0.372)	M14 x 1.5p	130.9 (5.154)	193 (7.598)	M8 x 1.25p x 9.7 (0.382) Min.	22.25 (0.876)	40 (1.575)	25.25 (0.994)	32.8 (1.291)	F05	5.6 (12.3)
		F52	31.8 (1.252)	190.0 (7.480)	66.6 (2.622)	42.33 (1.667) 42.07 (1.656)	27.0 (1.063) 26.0 (1.024)	11.8 (0.465)	9.50 (0.374) 9.46 (0.372)	M14 x 1.5p	130.9 (5.154)	193 (7.598)	M8 x 1.25p x 9.7 (0.382) Min.	22.25 (0.876)	40 (1.575)	25.25 (0.994)	32.8 (1.291)	F05	8.8 (19.4)
50	2	F51	38.2 (1.504)	178.0 (7.008)	70.9 (2.791)	47.06 (1.853) 46.80 (1.843)	27.0 (1.063) 26.0 (1.024)	11.8 (0.465)	9.50 (0.374) 9.46 (0.372)	M14 x 1.5p	135.7 (5.343)	193 (7.598)	M8 x 1.25p x 9.7 (0.382) Min.	22.25 (0.876)	50 (1.969)	27 (1.063)	36.75 (1.526)	F05	8.0 (17.6)
		F52	38.2 (1.504)	216.0 (8.504)	70.9 (2.791)	47.06 (1.853) 46.80 (1.843)	27.0 (1.063) 26.0 (1.024)	11.8 (0.465)	9.50 (0.374) 9.46 (0.372)	M14 x 1.5p	135.7 (5.343)	193 (7.598)	M8 x 1.25p x 9.7 (0.382) Min.	22.25 (0.876)	50 (1.969)	28 (1.102)	38.75 (1.526)	F05	10.9 (24.0)

(1) Dimensions C, D and F are indicated for the minimum and maximum tolerances to support mounting kits and automation. All other dimensions indicate their centerline.

(2) ISO platform dimensions as per ISO 5211.

Worcester® 51/52 Series Reduced Port Flanged Ball Valve

Sizes DN80 to DN200 (NPS 3 to 8)

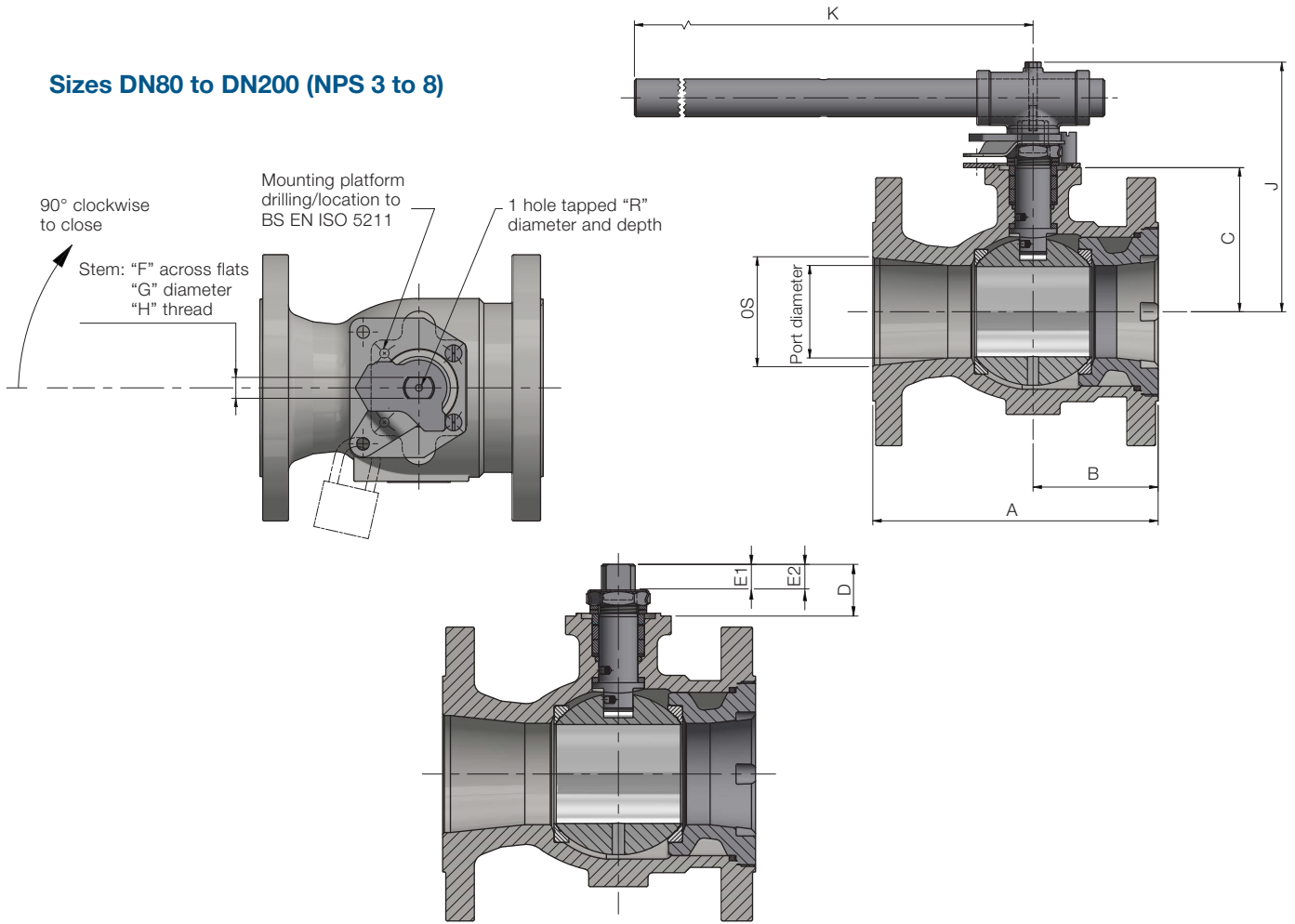

Dimensions indicated in mm (in.)

Valve Size		Valve Series	Min. Port Ø	A	B	C ⁽¹⁾	D ⁽¹⁾	E1 Min.	E2 Min.	Stem			J	K	S Ø	R Thread and Depth	ISO Size ⁽²⁾	Approx. Weight kg (lb)
DN	NPS									F ⁽¹⁾	G Ø	H Thread						
80	3	F51	65.8 (2.591)	203.0 (7.992)	89.0 (3.504)	102.7 (4.043) 102.3 (4.028)	34.0 (1.339) 33.0 (1.299)	16.6 (0.654)	17.1 (0.673)	14.99 (0.590) 14.95 (0.589)	21.95 (0.864) 21.85 (0.860)	M24 x 2.0p	175.7 (6.917)	349.0 (13.74)	78.2 (3.079)	M6 x 1.0p x 12.0 (0.472) Min.	F07	16.8 (37.0)
		F52	64.2 (2.528)	282.0 (11.102)	89.0 (3.504)	102.7 (4.043) 102.3 (4.028)	34.0 (1.339) 33.0 (1.299)	16.6 (0.654)	17.1 (0.673)	14.99 (0.590) 14.95 (0.589)	21.95 (0.864) 21.85 (0.860)	M24 x 2.0p	175.7 (6.917)	349.0 (13.74)	78.5 (3.090)	M6 x 1.0p x 12.0 (0.472) Min.	F07	25.1 (55.3)
100	4	F51	76.5 (3.012)	229.0 (9.016)	107.0 (4.213)	112.2 (4.417) 111.8 (4.402)	34.0 (1.339) 33.0 (1.299)	16.6 (0.654)	17.1 (0.673)	14.99 (0.590) 14.95 (0.589)	21.95 (0.864) 21.85 (0.860)	M24 x 2.0p	185.2 (7.291)	349.0 (13.74)	101.9 (4.012)	M6 x 1.0p x 12.0 (0.472) Min.	F07	25.4 (56.0)
		F52	76.5 (3.012)	305.0 (12.008)	107.0 (4.213)	119.7 (4.713) 119.3 (4.697)	45.0 (1.772) 43.0 (1.693)	22.0 (0.866)	22.6 (0.890)	18.99 (0.748) 18.94 (0.746)	27.95 (1.100) 27.85 (1.096)	M30 x 2.0p	206.7 (8.138)	557.0 (21.929)	104.5 (4.114)	M6 x 1.0p x 12.0 (0.472) Min.	F10	40.2 (88.6)
150 ⁽³⁾	6 ⁽³⁾	F51	102.3 (4.028)	267.0 (10.512)	129.0 (5.079)	140.4 (5.528) 140.0 (5.512)	45.0 (1.772) 43.0 (1.693)	24.7 (0.972)	21.5 (0.846)	18.99 (0.748) 18.94 (0.746)	27.95 (1.100) 27.85 (1.096)	M30 x 2.0p	-	-	154 (6.063)	M6 x 1.0p x 12.0 (0.472) Min.	F10	42.0 (92.6)
		F52	102.3 (4.028)	403.0 (15.866)	129.0 (5.079)	146.9 (5.783) 146.5 (5.768)	56.0 (2.205) 54.0 (2.126)	27.1 (1.067)	27.1 (1.067)	23.99 (0.944) 23.94 (0.943)	36.00 (1.417)	M36 x 2.0p	-	-	154 (6.063)	M8 x 1.25p x 12.0 (0.472) Min.	F12	73.1 (161.2)
200 ⁽³⁾	8 ⁽³⁾	F51	153 (6.024)	292.0 (11.496)	144.5 (5.689)	182.2 (7.173) 181.8 (7.157)	55.8 (2.197) 54.0 (2.126)	26.9 (1.059)	26.9 (1.059)	23.99 (0.944) 23.94 (0.943)	36.00 (1.417)	M36 x 2.0p	-	-	206.5 (8.13)	M8 x 1.25p x 12.0 (0.472) Min.	F12	75.5 (166.5)
		F52	153 (6.024)	419.0 (16.496)	144.5 (5.689)	194.4 (7.654) 194.0 (7.638)	69.0 (2.717) 67.0 (2.638)	35.0 (1.378)	35.0 (1.378)	31.99 (1.259) 31.93 (1.257)	48.00 (1.889)	M48 x 3.0p	-	-	206.5 (8.13)	M8 x 1.25p x 12.0 (0.472) Min.	F14	121.3 (267.4)

(1) Dimensions C, D and F are indicated for the minimum and maximum tolerances to support mounting kits and automation. All other dimensions indicate their centerline.

(2) ISO platform dimensions as per ISO 5211.

(3) DN150 (NPS 6) and DN200 (NPS 8) have gearboxes as standard. Consult factory for gearbox dimensions.

Technical information

Standards of compliance

Valve Specification	BS EN ISO 17292 and API 608 Pressure Equipment Directive 2014/68/EU Pressure Equipment Regulations SI 2016 Assessment Category: Pressure Accessory, Group 1 GAS, Table 6, Module 'H', Category III SIL 3 Capable TSG FM UL CRN TR CU 010/012/032
Face-to-face	F51 Series: BS EN 558-2 and ASME B16.10 F52 Series: BS EN 558-2 and ASME B16.10
Flanged Connections	BS EN 1759-1 and ASME B16.5 CL150 BS EN 1759-1 and ASME B16.5 CL300
Fugitive Emissions	ISO 15848: Class BH and API 641
Surface Quality	MSS SP-55
Fire Test	API 607 and ISO 10497
Pressure Test	BS EN 12266-1, ISO 5208 and API 598
Sour Service	NACE MR0175 and ISO 15156 or MR0103

Flow coefficients

Valve Size		Flow Coefficients		Equivalent Length of Pipe	
DN	NPS	Cv ⁽¹⁾	Kv ⁽²⁾	m	ft
15	½	8	7	1.19	3.9
20	¾	12	10	2.65	8.7
25	1	32	28	1.10	3.6
40	1½	82	71	1.13	3.7
50	2	120	104	1.98	6.5
80	3	350	303	2.16	7.1
100	4	720	623	2.10	6.9
150	6	1,020	882	6.22	20.4
200	8	1,800	1,557	11.49	37.7

(1) Cv: Flow in US gpm (measured with a pressure drop across the valve of 1 psi)

(2) Kv: Flow in m³/h (measured with a pressure drop across the valve of 1 bar)

Torque values

Valve Size		Valve Series	Maximum Allowable Stem Torque (MAST) ⁽¹⁾		Break-to-Open Torque With PTFE Seat ⁽²⁾		Gland Nut Tightening Torque	
DN	NPS		Nm	in.-lb	Nm	in.-lb	Nm	in.-lb
15	½	51	40	354	5	44	5 to 7	44 to 62
		52	40	354	5	44		
20	¾	51	40	354	5	44	5 to 7	44 to 62
		52	40	354	5	44		
25	1	51	40	354	7	62	6 to 10	53 to 86
		52	40	354	9	81		
40	1½	51	110	974	19	168	8 to 12	71 to 106
		52	110	974	26	230		
50	2	51	110	974	24	212	8 to 12	71 to 106
		52	110	974	32	283		
80	3	51	609	5,390	72	637	30 to 37	266 to 327
		52	609	5,390	105	929		
100	4	51	609	5,390	130	1,151	30 to 37	266 to 327
		52	1,046	9,256	190	1,682		
150	6	51	1,046	9,256	276	2,443	50 to 55	443 to 487
		52	1,568	13,878	435	3,850		
200	8	51	1,568	13,878	480	4,248	50 to 55	443 to 487
		52	4,249	37,607	675	5,974		

(1) MAST values calculated using the standard duplex stainless steel stem material

(2) Duty factor = 0; F51 @ 20 bar; F52 @ 50 bar; values are from AUTOSIZE 4.3; consult factory for other seat materials

Product code

Example 1: 20 F 51 5 5 6 6 I I 7 - Z 150 _____
 1 2 3 4 5 6 7 8 9 10 11 12 13 14

Example 2: 40 F 52 6 6 6 6 R I 7 I Z 300 _____
 1 2 3 4 5 6 7 8 9 10 11 12 13 14

1. Size

Code	DN	NPS
05	15	½
07	20	¾
10	25	1
15	40	1½
20	50	2
30	80	3
40	100	4
60	150	6
80	200	8

2. Variant

F	Fire-safe
CF	Cryogenic fire-safe, including bonnet extension
EF	EnviroSafe fire-safe
S	Shell-compliant
V	V-Flow CPT control valve

3. Series

51	Class 150 one-piece valve
52	Class 300 one-piece valve

4. Body

4	WCB/WCC
5	LCB/LCC
6	CF8M
7	Monel®
A	Alloy 20
C	Hastelloy® C

5. End/insert

4	WCB/WCC
5	LCB/LCC
6	CF8M
7	Monel
A	Alloy 20
C	Hastelloy C

6. Ball

6	CF8M
7	Monel
A	Alloy 20
C	Hastelloy C

7. Stem

6	Stainless steel ⁽¹⁾
Q	17-4PH
7	Monel ⁽²⁾
A	Alloy 20 ⁽²⁾
C	Hastelloy C ⁽²⁾

8. Seat

D	Delrin
T	V-PTFE
R	Reinforced PTFE
P	Fluorofill/Polyfill
U	UHMWPE
X	PEEK
A	Metal impregnated with PTFE
G	Metal impregnated with graphite

9. Body seal

T	V-PTFE
----------	--------

10. Thrust seal

7	25% glass PTFE
----------	----------------

11. Secondary stem seal/O-ring (optional)⁽³⁾

T	V-PTFE
V	FKM

12. Gland/stem packing

Z	Graphite
----------	----------

13. End connection/pressure class

150	ANSI B16.5 Class 150
300	ANSI B16.5 Class 300

14. Special

Consult factory for "Special" options.

Note: The 51/52 series valves include a gearbox as standard for sizes DN150 (NPS 6) or larger. This is not called out in the product code because it is a standard feature. Likewise, locking wrenches are included as standard for all valve sizes up to DN100 (NPS4).

- (1) Stainless steel stem material grade is selected based on stem strength and end use application requirements. Duplex as standard.
- (2) Depending on end use conditions, these stem materials may not comply with all the requirements of ISO 17292 or API 608.
- (3) Valve sizes DN50 (NPS 2) or below do not contain a secondary stem seal. As a result, this is reflected in the product code as a dash (-) to represent 'no option'.
- (4) Consult factory for other build configurations and materials.

© Hastelloy is a registered trademark of Haynes International.

© Monel is a registered trademark of International Nickel Co.



Digitize operations to improve uptime and yield at lower cost

Get the insights and tools needed to monitor, analyze and predict the performance of the Worcester 51/52 series valve with RedRaven from Flowserve, an end-to-end predictive maintenance solution.

Pairing a 51/52 series valve with a Logix™ 3800 digital positioner from Flowserve enables plant operators to leverage the internet of things (IoT) for a connected platform of smart products, software and services. They can quickly respond to equipment issues in order to minimize disruptions and downtime.

The Logix 3800 digital positioner — like most Flowserve fluid motion and control equipment — is RedRaven Ready. That means it's designed and built to accept RedRaven wired or wireless sensors using cloud architecture for condition monitoring and predictive analytics services.



REDRAVEN™ can enable companies to significantly improve equipment, process and system efficiency, productivity and reliability.

Contact your Flowserve representative or visit <https://www.flowserve.com/redraven> for more information.

Headquarters

Flowserve Corporation
5215 North O'Connor Blvd.
Suite 700
Irving, Texas 75039-5421 USA

North America

Cookeville, TN USA
Telephone: +1-931-432-4021

EMEA

Haywards Heath
United Kingdom
Telephone: +44-(0)-1444-314400

Flowserve Corporation has established industry leadership in the design and manufacture of its products. When properly selected, this Flowserve product is designed to perform its intended function safely during its useful life. However, the purchaser or user of Flowserve products should be aware that Flowserve products might be used in numerous applications under a wide variety of industrial service conditions. Although Flowserve can provide general guidelines, it cannot provide specific data and warnings for all possible applications. The purchaser/user must therefore assume the ultimate responsibility for the proper sizing and selection, installation, operation, and maintenance of Flowserve products. The purchaser/user should read and understand the Installation Instructions included with the product, and train its employees and contractors in the safe use of Flowserve products in connection with the specific application.

While the information and specifications contained in this literature are believed to be accurate, they are supplied for informative purposes only and should not be considered certified or as a guarantee of satisfactory results by reliance thereon. Nothing contained herein is to be construed as a warranty or guarantee, express or implied, regarding any matter with respect to this product. Because Flowserve is continually improving and upgrading its product design, the specifications, dimensions and information contained herein are subject to change without notice. Should any question arise concerning these provisions, the purchaser/user should contact Flowserve Corporation at any one of its worldwide operations or offices.

©2023 Flowserve Corporation. All rights reserved. This document contains registered and unregistered trademarks of Flowserve Corporation. Other company, product, or service names may be trademarks or service marks of their respective companies.

VATB000932-02 (EN/A4) June 2023