

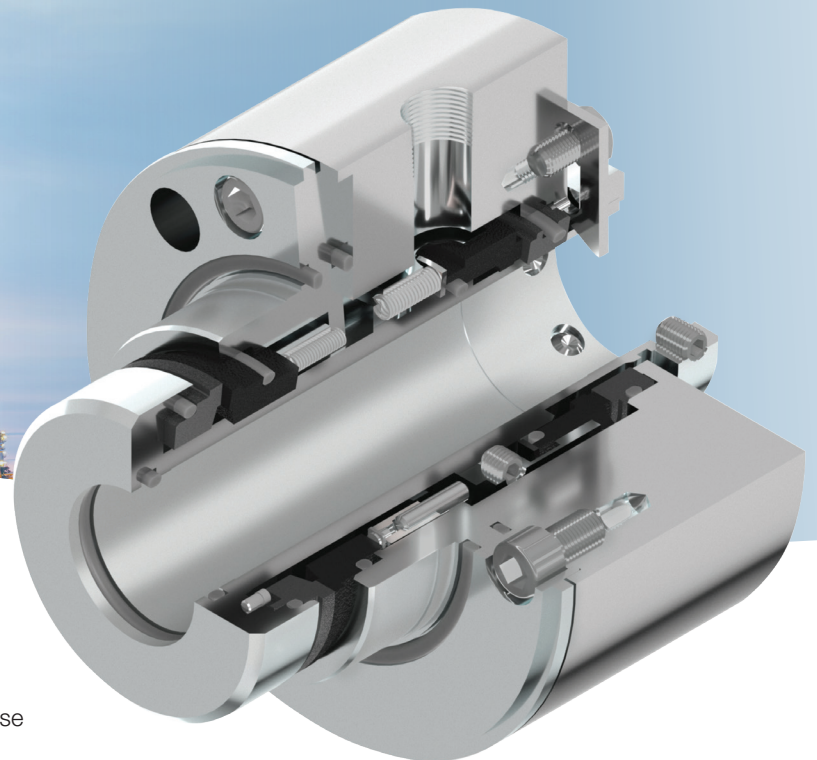

Allpac 682 Seal

Dual pressurized pusher



Engineered for contaminated services

Allpac 682 mechanical seals work to significantly increase pump reliability in dirty and contaminated applications by protecting dynamic design mechanisms. Suitable for services in refining, petrochemical and pipeline industries, Allpac 682 seals are fully compliant with API 682 Type A, Arrangement 3 requirements. Designed for long-term, dual pressurized operation with a protective barrier against process leakage, Allpac 682 seal faces are also double-balanced to tolerate upset pressure reversal events that would disrupt other seal types.

Features and benefits

- Clean design with springs outside the process fluid prevents clogging and hang-up for applications with up to 20% solids.
- Dual pressurized arrangement enables zero process emissions to optimally protect the environment and help facilities achieve decarbonization goals.
- Thick cross-section seal faces are double-balanced for high barrier pressure operation and upset pressure reversals, ensuring seal faces always remain closed.
- Robust drive mechanisms and low-stress seal face engagement withstand high startup torque found in cold oil-based viscous services.
- Premium silicon carbide seal faces are highly resistant to abrasive wear and enhanced with precision face topography for low-leakage, long-term operation.
- Outer seal options are available to provide the right level of performance capability and economy; all options maintain API 682 compliance and the correct level of barrier fluid circulation.
- Available sinusoidal groove in the sleeve maintains a continuous exchange of barrier fluid, keeping the seal faces appropriately cooled and lubricated.
- Engineered to retrofit into existing API 610 pump installations and resolve ongoing contamination challenges or can be specified in new, clean and/or dirty applications.
- Self-sustaining barrier fluid flow circulation through a Plan 53 A/B/C system or a standalone Plan 54 circulator enables cool operation for inner and outer seal faces.

Face topography and sinusoidal groove for enhanced performance

Smooth wave topography on the rotating seal face creates a strong, stable fluid film for optimum lubrication and protection from process leakage. A sinusoidal groove in the sleeve is available to further enhance seal face cooling by recirculating cool barrier fluid along the full length of the stationary face. The net result is long-term reliability and consistent performance over a wide operating range.

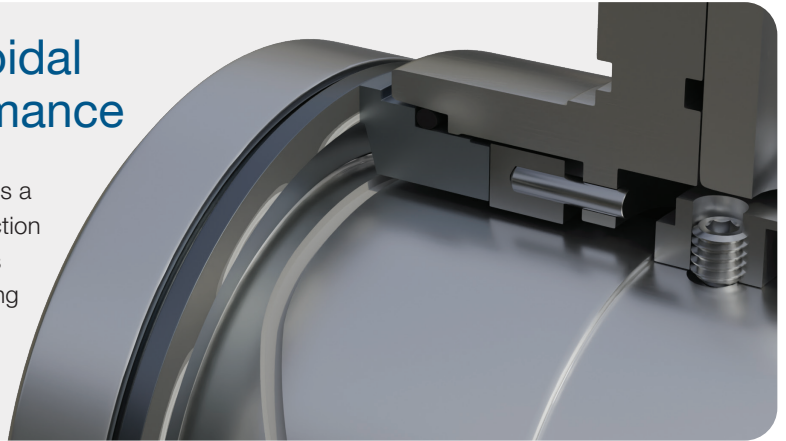

Materials of construction

Metal components

316 stainless steel, Alloy C-276, duplex

Seal faces

Silicon carbide

Gaskets

Fluoroelastomer, nitrile, perfluoroelastomer

Springs

Alloy C-276

Operating parameters

Process pressure

to 50.3 bar (730 psi)

Barrier pressure

1.4 to 15 bar (20 to 220 psi) over process

Temperature

-40°C to 204°C (-40°F to 400°F)

Speed

to 5,000 rpm or 23 m/s (75 ft/s)

Shaft size

19.0 to 127 mm (0.750 to 5.000 in.)

Popular dual seal combinations

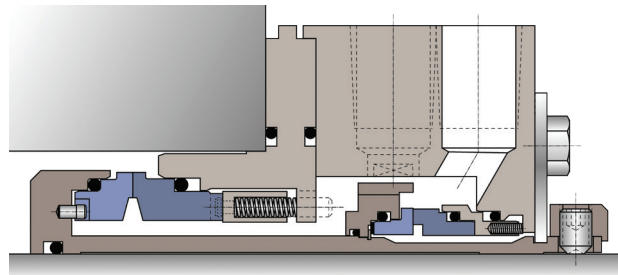

Allpac 682/ISC2-XP seal for low-duty service and barrier pressure up to 20.7 bar (300 psi)

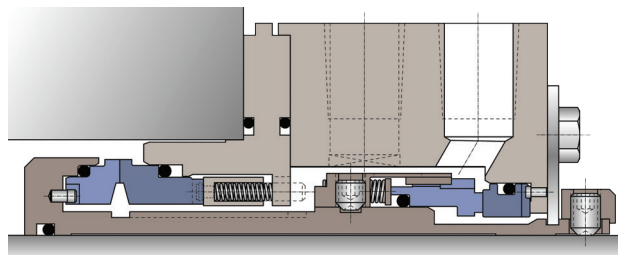

Allpac 682/QB seal for mid-range service and barrier pressure up to 51.7 bar (750 psi)

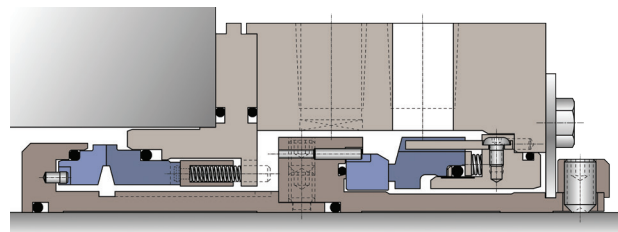

Allpac 682/HSH seal for high-duty service and barrier pressure up to 65.5 bar (950 psi)