

A625 Seal Cooler

A625 Motor Driven Seal Cooler Series



CONTENTS

1	Introduction	3
1.1	About this manual	3
1.2	How to use this manual	3
1.3	Other supplied Documents	3
1.4	Use of alerts and icons	3
2	Safety	3
2.1	Types of hazardous exposures	3
2.2	General safety	4
2.3	Trained and qualified personnel	4
2.4	Personal protective equipment (PPE)	4
2.5	Actions in extreme conditions	4
3	Environmental Considerations	4
3.1	Disposing of waste products	4
3.2	End of life equipment	4
4	Description	5
4.1	Product purpose	5
4.2	Design Features	5
4.3	Product components	6
4.4	The operating principle	6
4.5	Identifying the Product (Type Plate)	7
5	Preservation, Packing, Transport and Storage Requirements	7
5.1	Mechanical preservation instructions	7
	5.1.1 Preservation	7
	5.1.2 De-Preservation	7
5.2	Packing	7
5.3	Transportation and storage requirements	7
6	Installation	7
6.1	Introduction	7
6.2	Safety considerations	7
6.3	Installation requirements	8
6.4	Product Set-Up	8
	6.4.1 Mounting	8
	6.4.2 Connections	8
	6.4.3 Interconnecting piping	8
	6.4.4 Earthing	9
6.5	Installation procedure	9
7	Operation	9
7.1	Start-Up	9
7.2	Product Monitoring	10
7.3	Shut-Down Product	10
8	Maintenance	11
8.1	General guidelines	11
8.2	Periodic maintenance tables	11
8.3	Inspection Procedure	11
9	Troubleshooting	12
ANNEX I	13
ANNEX II	14

1. Introduction

1.1 About this manual

This manual (which is intended for operating, maintenance, and supervisory personnel) provides information on installing, operating, and maintaining the A625 Seal Cooler.

Installation in accordance with the following instructions will contribute to long and trouble-free operation of the assembly.

1.2. How to use this manual

Before using this manual, make sure you have fully read and understood the safety section, which can be found in chapter 2. When being new to the A625 Seal Cooler, pay attention to section 4, which describes the A625 Seal Cooler in detail.

Only trained and qualified personnel should use this manual. Refer to section 2.3. Inexperienced personnel should only work on this system under the supervision of qualified personnel.

When maintaining the A625 Seal Cooler, always make sure maintenance procedures are followed. Pay particular attention to the alerts and icons.

The A625 Seal Cooler may only be used for its main purposes as described in this manual. No adjustments can be made without the approval of Flowserve.

Changes, modifications, repairs or use under conditions deviating from the design specifications without prior permission of Flowserve will make the declaration of conformity and the nameplate invalid.

1.3. Other supplied Documents

Annex II contains the assembly drawing and sub-component manuals.

1.4. Use of Alerts and Icons

This manual uses “Notes”, “Cautions” “Warnings” and “Dangers” to alert you of important information and/or hazardous situations.

Note: “Notes” inform you of important additional information.

CAUTION	
	The equipment, product or surrounding area can be damaged if the “caution” is not obeyed.

WARNING	
	Personnel can be (seriously) injured, or the equipment can be seriously damaged if the “warning” is not obeyed.

DANGER	
	Personnel can be (seriously) injured if the “danger” sign is not obeyed.

The above icons are the general icons that are used for “Cautions”, “Warnings” and “Dangers”. More specific icons are also used, depending on the type of hazard. All Icon used in this manual are listed below:

WARNING	
	HIGH PRESSURE: Take caution when de-pressurizing the A625 Seal Cooler. The A625 Seal Cooler might have energy stored inside. Make sure that de-pressurizing happens slowly.

WARNING	
	HOT SURFACES: The A625 Seal Cooler and surrounding surfaces might be hot. Take care when touching components. Wear the appropriate Personal Protection Equipment (PPE), according to plant regulations.

WARNING	
	HAZARDOUS CHEMICALS: Dangerous chemical might be released during removal of the A625 Seal Cooler. Wear Personal Protective Equipment (PPE). Follow all safety regulations and Plant regulations.

2. Safety

2.1. Types of hazardous exposures

The following hazards can be present in the A625 Seal Cooler:

- High pressure
- Dangerous chemicals
- Dangerous moving parts (during installation)
- Electrical Hazards

If the A625 Seal Cooler has any external leaks, the process in which the A625 Seal Cooler is used should be stopped immediately and have the leak repaired by qualified personnel. When extreme conditions occur, and the possibility of a failure is imminent, plant-/end-user safety regulations shall be followed.

2.2. General Safety

When installing, operating and maintaining the A625 Seal Cooler, pay attention to the following:

- Obey all applicable safety laws and regulations.
- Obey all plant regulations.
- Make sure that only trained and qualified personnel work on it. Refer to section 2.3.
- Read and understand each part of this manual.
- Follow the installation, operation, and maintenance procedures exactly.
- Wear the relevant Personal Protective Equipment (PPE). Refer to section 2.4.
- Never work alone (if there is a possibility of an accident).
- Read the plant requirements for handling hazardous materials

2.3. Trained and qualified personnel

Qualified personnel are people who have been authorized by those responsible for the safety of the plant to perform the necessary work, and who can recognize and avoid possible dangers. The following aspects determine the qualification of personnel:

- Appropriate training
- Relevant experience
- Knowledge of relevant standards and specifications
- Knowledge of accident prevention regulations
- Knowledge of plant regulations and operating conditions

2.4. Personal protective equipment (PPE)

The A625 Seal Cooler is often used for applications containing high-pressure, high-temperature and/or toxic chemicals. When performing operating or maintenance tasks, make sure you wear the appropriate Personal Protective Equipment (PPE): protective clothing, gloves, safety glasses, etc.

Always follow local regulations regarding PPE.

2.5. Actions in extreme conditions

In the unlikely event of emergency operating conditions always follow emergency plant regulations. Immediate evacuation of service personnel to be according plant regulations.

3. Environmental Considerations

CAUTION	
	You are required by law to dispose waste products and end of life equipment, according to local regulations.

3.1. Disposing of waste products

Make sure waste products are diverted to a safe and suitable location. Always follow local and plant regulations.

Any waste products resulting from the use or maintenance of the A625 Seal Cooler must be disposed of according to local environment laws and regulations.

3.2. End of life equipment

WARNING	
	HAZARDOUS CHEMICALS: Dangerous chemical might be released during removal of the A625 Seal Cooler. Wear Personal Protective Equipment (PPE). Follow all safety regulations and Plant regulations.

WARNING	
	HIGH PRESSURE: Take caution when de-pressurizing the A625 Seal Cooler. The A625 Seal Cooler might have energy stored inside. Make sure that de-pressurizing happens slowly.

WARNING	
	HOT SURFACES: The A625 Seal Cooler and surrounding surfaces might be hot. Take care when touching components. Wear the appropriate Personal Protection Equipment (PPE), according to plant regulations

When the equipment reaches the end of life, the shutdown procedure (section 7.4) shall be followed. The equipment must then be deinstalled and transported to a safe location. Always pay extra attention to safety!

Note: End of life equipment must be disposed of according to local environment laws and regulations.

4. Description

The A625 Seal Cooler is a low capacity forced draft air cooler that has a compact design and is constructed to be able to operate in hazardous environments. The A625 Seal Cooler can be used to cool the barrier fluids in barrier/buffer plans or to cool the product flush in a flush plans. Cooling the seal chamber improves the operating conditions for the mechanical seal.



Figure 1. A625 Seal Cooler

4.1. Product purpose

The A625 Seal Cooler, displayed in figure 1, is designed as forced draft air cooler. These products are intended to cool fluids without the use of cooling water. Commonly, they are used in applications where cooling water is not readily available. The A625 Seal Cooler is designed to comply with API 682 4th edition.

The purposes of the A625 Seal Cooler in different applications are:

- To provide cooling for process or pumping fluid in a single or dual seal arrangement in an API piping Plan 21, 23, and 41
- To provide cooling for buffer fluid in an un-pressurized dual seal arrangement in an API Piping Plan 52
- To cool down barrier fluid in a pressurized dual seal arrangement in an API Piping Plan 53A, 53B, 53C and 54

4.2. Design Features

Operating conditions may vary but shall never exceed the design conditions. Refer to the attached drawing of the A625 Seal Cooler for boundary dimensions, design conditions and operating constraints.

The key design features of the A625 Seal Cooler are listed below:

- Meets API standard 682 4th edition design requirements
- Meets ASME B31.3 design requirements
- M04 Motor ATEX classification “II 2 G Ex d IIB T4 Gc”
- Housing created from 304SS to be corrosion resistant
- Compact design can be fitted on an auxiliary system stand without the need to increase the system stand mounting plate.
- Compliance to Pressure Equipment Directive
- Compliance to CRN Canada-wide
- Option for North American NEC/CSA certified electric motor
- Designed to withstand pressures up to 2,900PSIG (200 BarG), refer to attached drawing for design specifications.
- Designed to withstand temperatures up to 700°F (371°C), refer to attached drawing for design specifications.

A625 Seal Cooler

4.3. Product components

The A625 Seal Cooler is an engineered cooler developed by Flowserve. For design specifics refer to the GA drawing. The parts and materials can deviate per design:

Number	Part	Function	Material
1	Finned Tube	Part where the fluid is cooled. The fins extend the contact area with the air for the pipe or tube to have more efficient cooling.	316 Stainless Steel / Aluminum
2	Supporting Structure	Cooler support with mounting holes. Designed to carry the weight of all cooler components	Stainless Steel
3	Metal Guard	Prevents parts/limbs from getting in collision with the fan. Guides the airflow over the finned tube.	Stainless Steel
4	Impeller	Create an airflow over the finned tube to enlarge the heat dissipation of the finned tube.	Aluminum fin with galvanized steel tube.
5	Electric Motor	Rotate the fan with sufficient power and speed to get the required airflow.	Carbon Steel Factory Paint
6	Fasteners	Attach loose components to each other.	Stainless Steel

Table 1 – A625 Seal Cooler Components

4.4. The operating principle

The fluid that requires cooling flows in through the top of the A625 Seal Cooler. From there the fluid flows down in a helical coil. The process connection may be flanges, tube end, tube union or National Pipe Taper Female (NPTF). Air is drawn through the bottom vent and through the top gap between the motor and the housing. This is pulled through with a squirrel cage fan and is blown through the coil and out through the cooler shroud. On double stacked coolers, only the top cooler has a fan.

The temperature difference between the process media flowing through the A625 tube and the outside environment enable heat transfer with the air being heated and the media in the tube will be cooled. The fins enlarge the heat exchange surface area. The fan provides a forced airflow over the finned tubes and therefore positively influences the heat transfer rate.

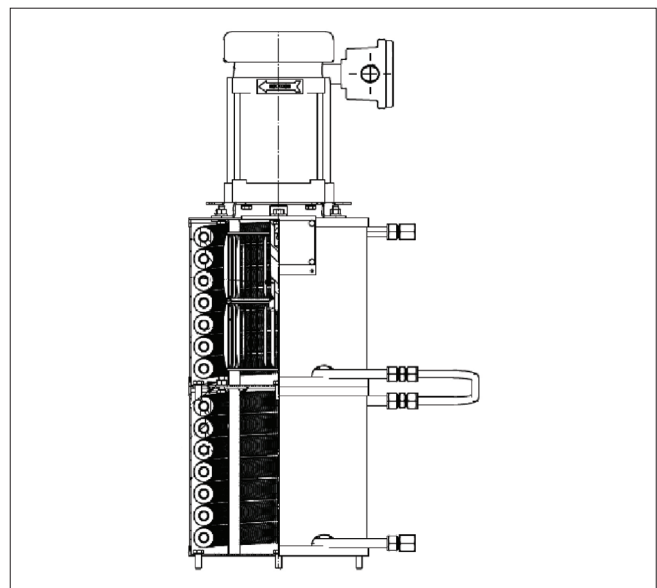

Figure 2. A625 Seal Cooler operating principle

4.5. Identifying the Product (Type Plate)

The nameplate is, as per Flowserve standard, shown on the general assembly drawing.

5. Preservation, Packing, Transport and Storage Requirements

5.1. Mechanical preservation instructions

5.1.1. Preservation

Equipment should not be sealed in a way that it will obstruct inspection. Access for normal inspection and preservation maintenance shall be provided. Internal surfaces of pressure vessels, piping systems and similar equipment shall be dried and cleaned of surface corrosion and foreign material.

The A625 Seal Cooler shall be thoroughly cleaned and dried after manufacturing and testing, prior to application of preservatives.

For equipment where water is used for cleaning or pressure testing, the water shall have antifreeze medium added unless the water is completely drained off. This also applies if the ambient temperature is below 4°C during any of these operations.

Internal surfaces wholly consisting of corrosion resistant materials shall not be preserved unless stated otherwise.

5.1.2. De-Preservation

For de-preservation the applicable dust caps/plugs need to be removed prior to commissioning. During hook up it is mandatory to keep these caps/plugs in place for as long as possible to prevent contamination.

5.2. Packing

WARNING	
	CRUSH HAZARD: Possible injury and/or trapped limbs. Take care to avoid being trapped or crushed between heavy, moving objects when (un)boxing the cooler.

The A625 Seal Cooler is to be carefully lifted inside a timber box.

Always make sure that proper lifting devices are used.

To prevent damage during transport all equipment needs to be properly secured inside their timber package with suitable bolting, straps, or wooden supports.

For unboxing, the equipment must be lifted carefully out of its shipping box.

5.3. Transportation and storage requirements

Note: The following requirements apply to the A625 Seal Cooler and all related equipment:

Transport and storage criteria	Requirements
Transportation	The system must be transported and stored in the unopened, original shipping box.
Suspect damaged during transportation	Inspect A625 Seal Coolers that have been dropped or have been subjected to impacts during transport to confirm that they are operational before installation.
Warehouse requirements	The warehouse must be dry and dust free.
Long-term storage	After a storage period of 2 years, inspect the A625 Seal Cooler before installation.
Preserving installed A625 Seal Cooler Series	The preserving medium prevents damage to the installed system or mechanical seal (i.e. preventing fouling or chemical attack). Contact Flowserve if you are unsure which preserving medium to use.

Table 2 - Transport and Storage Criteria

6. Installation

6.1. Introduction

WARNING	
	CRUSH HAZARD: Possible injury and/or trapped limbs. Take care to avoid being trapped or crushed between heavy, moving objects when installing the coolers.

Before installing the A625 Seal Cooler, make sure you have read and understood the installation requirements in this section. If you have any questions regarding the installation of the A625 Seal Cooler, contact your local Flowserve representative.

6.2. Safety considerations

WARNING	
	CHECK BEFORE DISASSEMBLING: Under no circumstances should the A625 Seal Cooler be disassembled while it still contains any hazardous materials or when it is pressurized.

DANGER	
	SUFFOCATION HAZARD: Breathing hazardous chemicals in a confined space can result in sudden unconsciousness or death. Take extra care when working in confined areas.

A625 Seal Cooler

Position the A625 Seal Cooler as close to your main equipment as possible. Make sure there is sufficient room for:

- Evacuation of the plant in case of an emergency (do not block walkways and emergency exits)
- Safe operation and maintenance of the system

If the A625 Seal Cooler is being installed in a confined area, make sure there is adequate ventilation.

Adequate ventilation is required for:

- Safe venting of the A625 Seal Cooler interconnecting piping.
- Sufficient Airflow to enable cooling of the process media.

6.3. Installation requirements

Before installation the following shall be checked:

- Any possible damage due to transport or storage
- Cleanliness, required before operation
- Existence of the nameplate with correct inspection markings and design/test conditions

6.4. Product Set-Up

6.4.1. Mounting

The A625 Seal Cooler has four mounting studs that are 3/8-16 thread and 7/8in long. These are set on a 10.5in circle. This allows the cooler to be mounted in four different positions, each rotating 90 degrees. All mounting studs should be used to secure the cooler. If a grounding lug is required, it should not be installed between the cooler and the mounting surface to avoid distortion in the cooler. If additional threading is available on the mounting stud, secure it with a second nut. If no space is available, use the mounting studs located on top of the cooler housing that are used to secure the motor. See Figure 3 for more details.

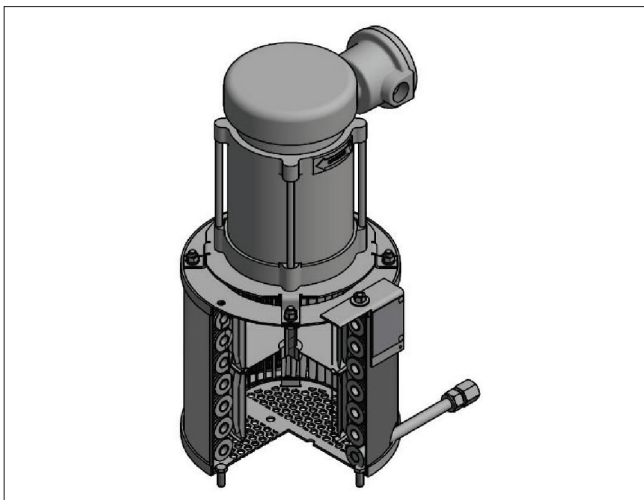

Figure 3. A625 Seal Cooler Mounting Holes

Mounting of the A625 Seal Cooler should always comply to the points listed below:

- The A625 Seal Cooler shall be mounted in a vertical position so all trapped gas/air can be vented and the process media could be drained completely.
- When mounting the A625 Seal Cooler make sure the bottom of the cooler has at least 12in (300mm) clearance below.
- Make sure that the lower connection of the A625 Seal Cooler should be located at least 18in (450mm) above the pump centerline and preferably not more than 24in (600mm).

6.4.2. Connections

When the A625 Seal Cooler is mounted the interconnecting piping needs to be connected. Below, for each application in which the A625 Seal Cooler could be used, is explained which utility needs to be connected to which A625 Seal Cooler connection.

6.4.2.1. A625 Seal Cooler in a flush plan

When the A625 Seal Cooler is used in a flush plan (plan 21, 23), the top connection shall be connected to the flush outlet connection of the mechanical seal, while the bottom flange shall be connected to the flush inlet connection of the mechanical seal.

6.4.2.2. A625 Seal Cooler in a buffer/barrier plan

When the A625 Seal Cooler is used in a buffer/barrier plan (plan 52 and 53's), the top connection shall be connected to the buffer/barrier outlet connection of the mechanical seal, while the bottom flange shall be connected to the buffer/barrier inlet connection of the mechanical seal.

6.4.3. Interconnecting piping

The flow of fluid through the A625 Seal Cooler is either generated by:

- a pumping device, included in the seal design
- a circulation pump
- thermosyphoning by natural convection

The interconnecting piping between the A625 Seal Cooler and the main equipment must be correctly fitted; otherwise the flow of the fluid through the A625 Seal Cooler will be restricted and have a negative impact on the performance.

Pay attention to the following points:

- Minimize the number of restrictions (for example, limit the number of elbow/tee fittings).
- Unless otherwise specified, the pipe size should be ¾" and schedule shall be the same as the system piping.

A625 Seal Cooler

- The pipes must be clean and free of burrs.
- The total pipe length and number of bends shall be kept to a minimum.
- Use smooth, large radius bends; do not use elbows, tees, etc.
- Pipe runs should be sloped continuously up or down to allow for adequate circulation, proper venting and draining.
- Make sure that the loop, including seal flange, does not include vapor traps. When vapor traps cannot be avoided, a proper venting solution shall be added.
- For threaded connections, do not use Teflon tape but an anaerobic thread sealant.
- Leak testing is recommended after assembly. Refer to end user specifications or procedures.

6.4.4. Earthing

Make sure the A625 Seal Cooler is properly earthed. One of the motor mounting studs can be used as an earthing lug.

DANGER	
	EXPLOSION RISK: Static electricity can build up and ignite flammable vapors. The system must be correctly earthed to minimize the risk of explosion caused by static electricity.

6.5. Installation procedure

Use this procedure to install or reinstall the system.

Procedure

1. Before installing the A625 Seal Cooler, inspect all components for damage. If any of the components are damaged, you should report this to your local Flowserve representative. Refer to section 6.3.
2. Determine the installed position of the system. Refer to the mounting requirements, section 6.4.1.
3. The A625 Seal Cooler shall not be moved by hand. It is equipped with a lifting lug. Use an appropriate lifting device to position the A625 Seal Cooler as close as possible to the main equipment. Make sure you leave sufficient room for operation and maintenance purposes.

WARNING	
	CRUSH HAZARD: Possible injury and/or trapped limbs. Take care to avoid being trapped or crushed between heavy, moving objects when installing the cooler.

4. Make sure that the A625 Seal Cooler is installed in a rigid support to counteract any vibrations and instability.

WARNING	
	HIGH PRESSURE: Take caution when de-pressurizing the A625 Seal Cooler. The A625 Seal Cooler might have energy stored inside. Make sure that de-pressurizing happens slowly.

5. Connect the A625 Seal Cooler connections. Refer to section 6.4.2.
6. Manufacture the interconnecting piping according to the Installation requirement. Refer to section 6.4.3.
7. Make sure the installation is correctly earthed to prevent the potential risk of explosion caused by static electricity.
8. Connect the electric motor to the available electric network.

Note: Leak testing is recommended after assembly. Refer to end user specifications or procedures.

7. Operation

7.1. Start-Up

Use this procedure if:

- The Air Cooler is being set-up for the first time, or
- The flushing/barrier/buffer fluid has been completely drained from the system.

When the A625 Seal Cooler is installed the application can be started up. The below procedure shall be used for starting up the A625 Seal Cooler.

1. Make sure the A625 Seal Cooler is installed correctly, refer to chapter 6.5.
2. Activate the fan of the A625 Seal Cooler and make sure that there is sufficient airflow without any restrictions.
3. Make sure commissioning of the system has been performed properly. Ensure that all the trapped gas/air is vented from the system and interconnecting piping and that the system can be completely drained.
4. Make sure that the fan can spin freely without contacting any stationary surfaces.
5. Start up the pump according end user/plant procedures.

7.2. Product Monitoring

WARNING	
	HIGH PRESSURE: Take caution when de-pressurizing the A625 Seal Cooler. The A625 Seal Cooler might have energy stored inside. Make sure that de-pressurizing happens slowly.

WARNING	
	HOT SURFACES: The A625 Seal Cooler and surrounding surfaces might be hot. Take care when touching components. Wear the appropriate Personal Protection Equipment (PPE), according to plant regulations.

WARNING	
	HAZARDOUS CHEMICALS: Hazardous chemicals might be released during removal of the A625 Seal Cooler. Wear Personal Protective Equipment (PPE). Follow all safety regulations and Plant regulations.

Use this procedure to monitor the system:

1. Monitor the A625 Seal Cooler for correct operation. Also refer to the Periodic maintenance tables in section 8.2.
2. Make sure:
 - there are no leaks
 - the seals and/or bearings are not running hot
 - there is no cavitation in the system
 - there is no heavy vibration in the system
 - the fan is not contacting any stationary surface
3. If you notice any problems with the A625 Seal Cooler, follow plant regulation for reporting and correcting faulty equipment.

A625 Seal Cooler performance should be monitored periodically. Baseline temperatures should be collected soon after equipment commissioning.

Periodically the A625 Seal Cooler temperature, pressure and flow should be monitored to prevent damage or failure to the equipment.

7.3. Shut-Down Product

WARNING	
	HIGH PRESSURE: Take caution when de-pressurizing the A625 Seal Cooler. The A625 Seal Cooler might have energy stored inside. Make sure that de-pressurizing happens slowly.

WARNING	
	HOT SURFACES: The A625 Seal Cooler and surrounding surfaces might be hot. Take care when touching components. Wear the appropriate Personal Protection Equipment (PPE), according to plant regulations.

WARNING	
	HAZARDOUS CHEMICALS: Hazardous chemicals might be released during removal of the A625 Seal Cooler. Wear Personal Protective Equipment (PPE). Follow all safety regulations and Plant regulations.

The A625 Seal Cooler may be disconnected only by qualified personnel, in accordance with national, plant- and end-user safety regulations and Chapter 2 in this manual.

Check if the A625 Seal Cooler can be shut down. Check if the A625 Seal Cooler can be de-pressurized without negatively affecting the mechanical seal installed in main equipment. System cannot be shut down if any of the following main equipment conditions occur:

- Main equipment/ Pump is on hot stand-by
- Main equipment/ Pump is pressurized
- Main equipment/ Pump is in operation

Note: Always shut down the system according to plant regulations/ end user safety procedures.

If the above points are checked, the A625 Seal Cooler can be shut down according to the procedure below:

- Make sure the pump is shut down according end-user/plant regulations
- Turn off the fan of the A625 Seal Cooler
- De-pressurize the A625 Seal Cooler
- Drain the A625 Seal Cooler

Note: For (re)-installation, removal and maintenance work, the A625 Seal Cooler must be de-pressurized (and drained if required).

8. Maintenance

8.1. General guidelines

Periodic maintenance must be done at regular intervals (weekly, monthly, yearly). Refer to the following tables.

All liabilities and warranties to Flowserve for damage incurred using non-original replacement parts and accessories will be rendered null and void.

To avoid potential explosion hazards during maintenance, the tools, cleaning and painting materials used must not give rise to sparking or adversely affect the ambient conditions. Where there is a risk from such tools or materials the Cooler must be moved to a safe area for dismantling.

8.2. Periodic maintenance tables

Use the following tables to plan the periodic maintenance for your system (refer to the table of contents and the Appendix for the relevant information)

Weekly maintenance
Check the seal, A625 Seal Cooler, and interconnecting pipe work for leaks. Rectify if necessary.
Check if the A625 Seal Cooler is not vibrating.
Check the fluid pressure, flow and temperature.
The fins should be clean. Clean of dust and other substances that will reduce heat exchange to the environment.

Monthly maintenance
Do all weekly periodic maintenance procedures.
Check all optional earthing connections. Rectify if necessary.
Check the fluid for impurities.
Vent the A625 Seal Cooler interconnecting pipe lines.
Inspect the shaft bearing for dirt or dust and remove.
Check if all electrical connections if no damage has occurred.

Yearly maintenance
Do all weekly and monthly periodic maintenance procedures.
Grease motor and shaft bearing per the motor IOM

Table 3 - Periodic Maintenance Tables

8.3. Inspection Procedure

WARNING	
	HIGH PRESSURE: Take caution when de-pressurizing the A625 Seal Cooler. The A625 Seal Cooler might have energy stored inside. Make sure that de-pressurizing happens slowly.

WARNING	
	HOT SURFACES: The A625 Seal Cooler and surrounding surfaces might be hot. Take care when touching components. Wear the appropriate Personal Protection Equipment (PPE), according to plant regulations.

WARNING	
	HAZARDOUS CHEMICALS: Hazardous chemicals might be released during removal of the A625 Seal Cooler. Wear Personal Protective Equipment (PPE). Follow all safety regulations and Plant regulations.

The product maintenance procedure is as follows:

- Remove the A625 Seal Cooler from service. Refer to section 7.3. Shut-Down Product.
- Internally and externally clean the A625 Seal Cooler without damaging the equipment. The circular and top guard may be removed for cleaning purposes, but make sure they are re-assembled according to the assembly drawing. If there are any doubts during this step, please ask a Flowserve representative for clarification.
- Inspect all components for damage or corrosion and replace as needed.
- Re-install the A625 Seal Cooler. Refer to section 6.5. Installation Procedure.

9. Troubleshooting

Use the following table to troubleshoot the system. Once you have identified the problem, use the procedures in this manual to maintain the A625 Seal Cooler. If you are not sure how to troubleshoot or maintain your A625 Seal Cooler, please contact your local Flowserve representative.

Note: the recommended response actions always include notify the supervisory authority and respond according plant regulation.

Parameter	Indication	Possible Cause	Solution
Pressure	Low	<ul style="list-style-type: none"> Leakage in connections, gaskets, piping Mechanical seal failure Flush/Barrier source supply pressure fails. 	<ul style="list-style-type: none"> Check connections for leakage Check gaskets for leakage Check piping for leakage Check mechanical seal
Pressure	High	<ul style="list-style-type: none"> Inner mechanical seal failure Process discharge closed. 	<ul style="list-style-type: none"> Repair mechanical seal Open discharge line
Flow	Low	<ul style="list-style-type: none"> The A625 Seal Cooler or its interconnecting piping is clogged. Flush/Barrier source supply pressure fails. 	<ul style="list-style-type: none"> Check for blockages Localize blockage
Temperature	High	<ul style="list-style-type: none"> Insufficient circulation Fan stopped working Outside of cooler not clean <ul style="list-style-type: none"> Guard clogged 	<ul style="list-style-type: none"> Check the power supply Check cleanliness off the fins, refer chapter 8.3 Check if nothing is blocking the air flow through the guard

Table 4 - Localization and Elimination of Vaults, Damages and their Consequences

ANNEX I

System logbook

Copy and use this logbook to record periodic or corrective maintenance done on your system. Use the following codes and enter remarks, the date, and your name:

Weekly maint.= W	Monthly maint. = M	Yearly maint.= Y	Adjust = A	Replace = R
------------------	--------------------	------------------	------------	-------------

Code	Remarks	Date	Name

A625 Seal Cooler

ANNEX II



Headquarters

Flowserve Corporation
5215 North O'Connor Blvd.
Suite 700
Irving, Texas 75039-5421 USA

Flowserve Corporation has established industry leadership in the design and manufacture of its products. When properly selected, this Flowserve product is designed to perform its intended function safely during its useful life. However, the purchaser or user of Flowserve products should be aware that Flowserve products might be used in numerous applications under a wide variety of industrial service conditions. Although Flowserve can provide general guidelines, it cannot provide specific data and warnings for all possible applications. The purchaser/user must therefore assume the ultimate responsibility for the proper sizing and selection, installation, operation, and maintenance of Flowserve products. The purchaser/user should read and understand the Installation Instructions included with the product, and train its employees and contractors in the safe use of Flowserve products in connection with the specific application.

While the information and specifications contained in this literature are believed to be accurate, they are supplied for informative purposes only and should not be considered certified or as a guarantee of satisfactory results by reliance thereon. Nothing contained herein is to be construed as a warranty or guarantee, express or implied, regarding any matter with respect to this product. Because Flowserve is continually improving and upgrading its product design, the specifications, dimensions and information contained herein are subject to change without notice. Should any question arise concerning these provisions, the purchaser/user should contact Flowserve Corporation at any one of its worldwide operations or offices.

©2024 Flowserve Corporation. All rights reserved. This document contains registered and unregistered trademarks of Flowserve Corporation. Other company, product, or service names may be trademarks or service marks of their respective companies.

SSIOM001169-01 (EN/AQ) October 2024